

E73158-ND

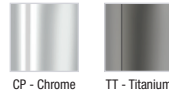

Collection: COMPOSED

Finish*:



Main features:



Features

- WEIGHT: 2 kg
- INSTALLATION TYPE: 1 hole
- TYPE: Single-lever
- HEIGHT UNDER SPOUT: 222
- CONNECTION: With supply hoses
- WATER/ENERGY-SAVING: WATER-SAVING
- INSTALLATION TYPE: 1 hole
- No side lift, no waste
- MATERIAL: Metal
- NORMS AND REGULATION: ACS : 14ACCLY511
- FLOW RATE: Maximum flow 5 l/min
- SPOUT PROJECTION: 181
- MECHANISM: Ceramic disc cartridge
- WASTE : Without waste
- MECHANISM GUARANTEE: 5 years
- Anti-scale aerator.

Consumer benefits

- Titanium PVD finish guaranteed 25 years.

Installation benefits

- Threaded tube for easier installation

Technical drawing

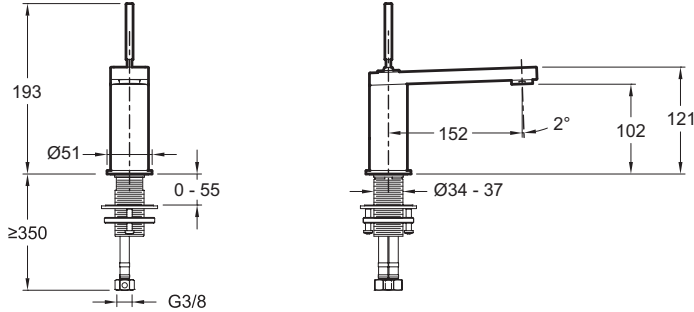

Product Specification: Single-lever washbasin mixer - "Joystick" lever. E73158-ND. Collection: COMPOSED. WEIGHT: 2 kg. MATERIAL: Metal. INSTALLATION TYPE: 1 hole. NORMS AND REGULATION: ACS : 14ACCLY511. TYPE: Single-lever. FLOW RATE: Maximum flow 5 l/min. HEIGHT UNDER SPOUT: 222. SPOUT PROJECTION: 181. CONNECTION: With supply hoses. MECHANISM: Ceramic disc cartridge. WATER/ENERGY-SAVING: WATER-SAVING. WASTE : Without waste. INSTALLATION TYPE: 1 hole. MECHANISM GUARANTEE: 5 years. No side lift, no waste. Anti-scale aerator..

**Due to possible variations in computer and printer calibrations, technical factors and certain finish characteristics, the colors you see may not accurately portray the actual colors and are provided as a guide only.*