



Roca

WAIKIKI-N

A248347

A248429

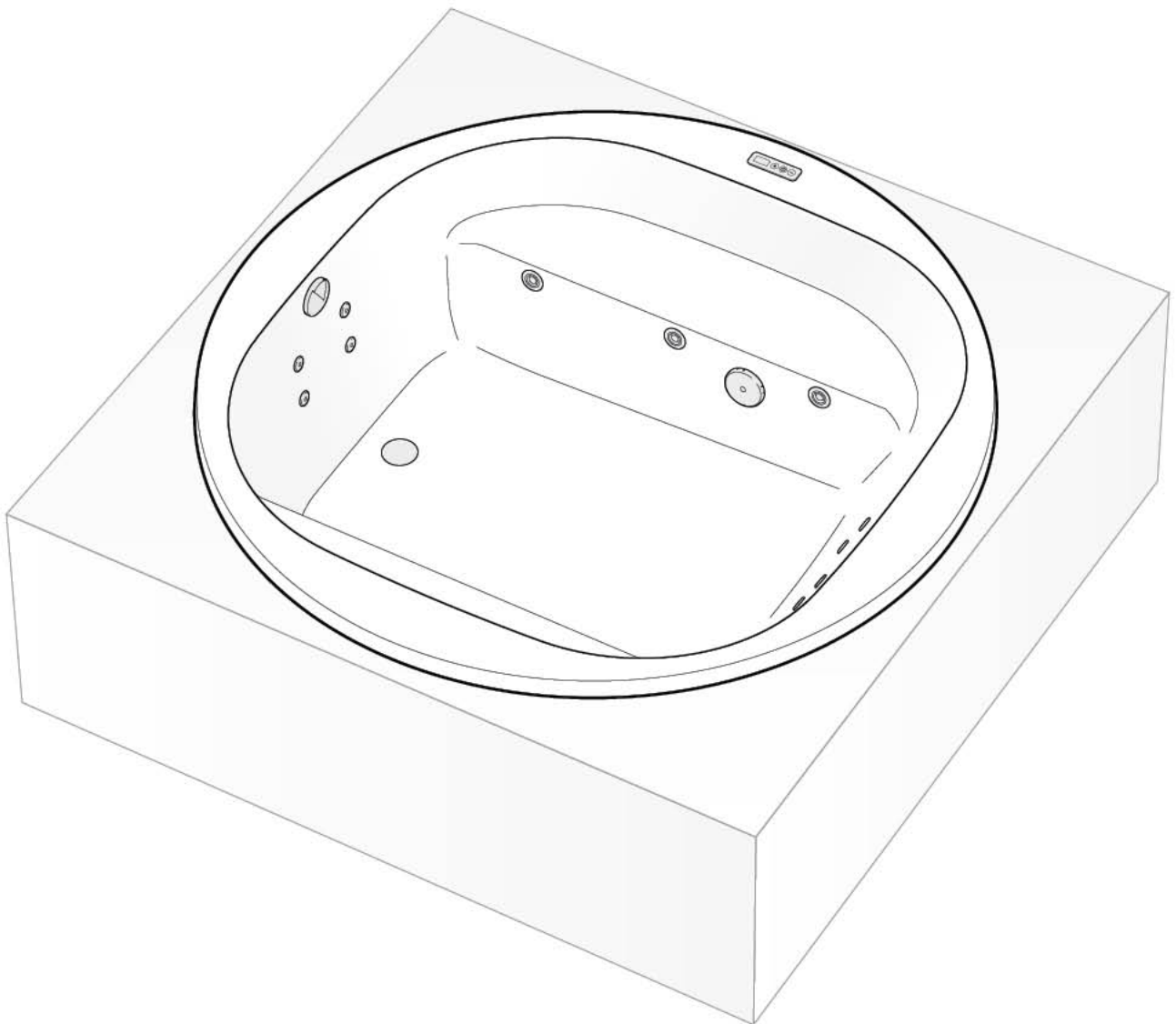

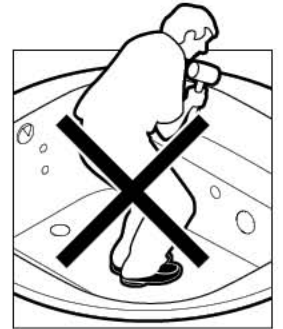
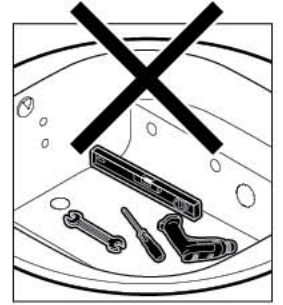
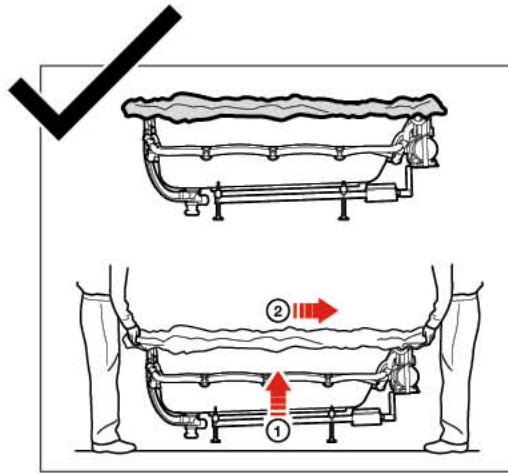
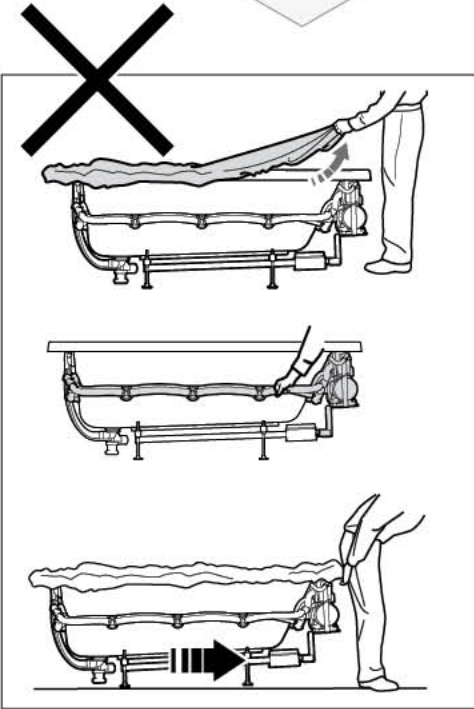
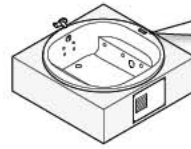
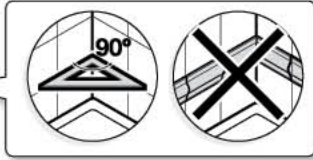
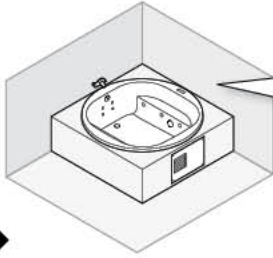

1



Ø 40
Ø 50

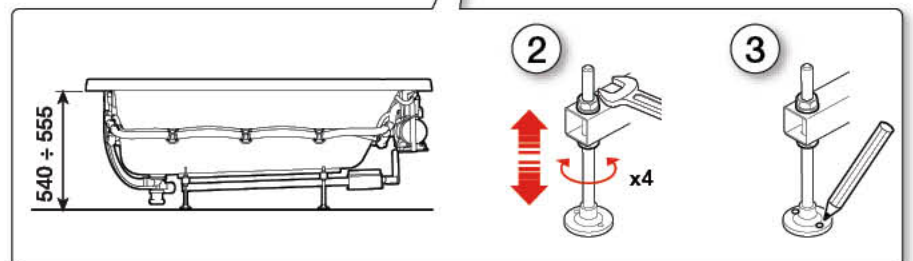

2



1

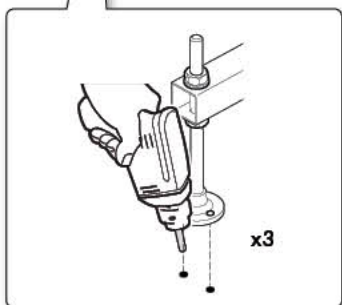
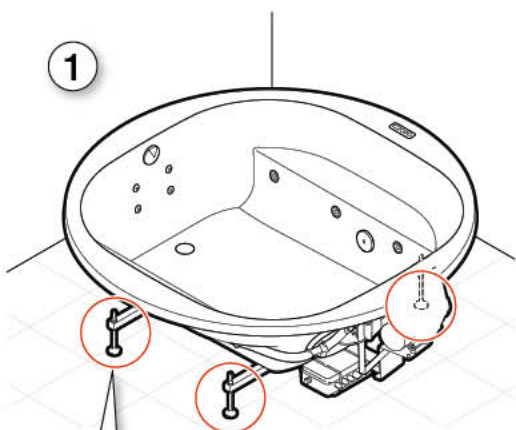

2

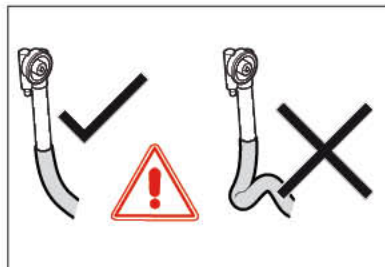
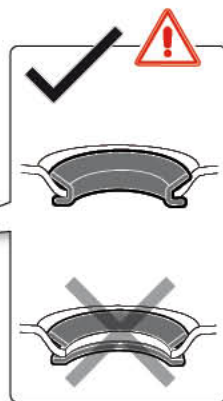
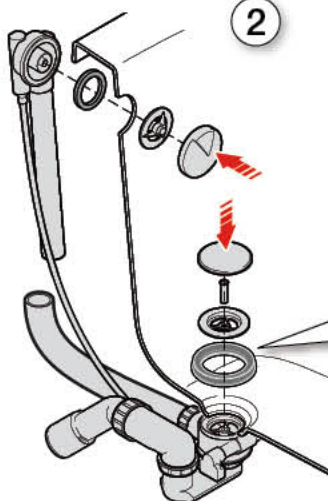

3



1

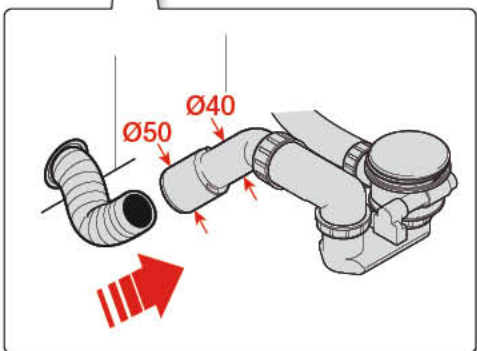
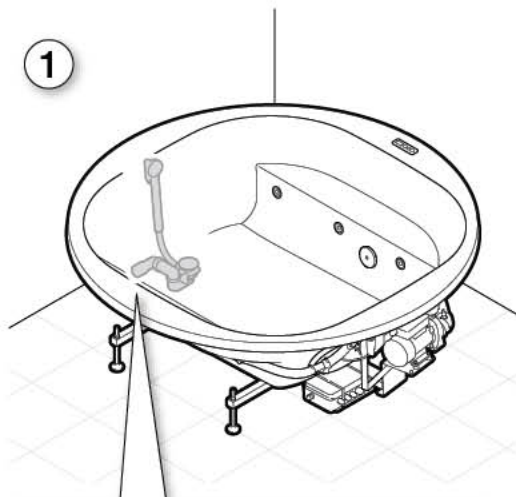

2

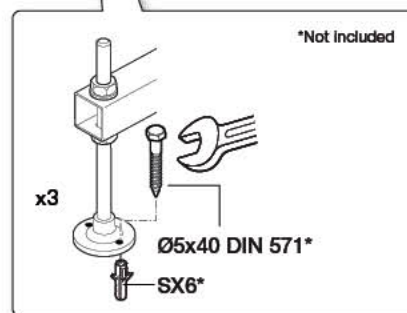
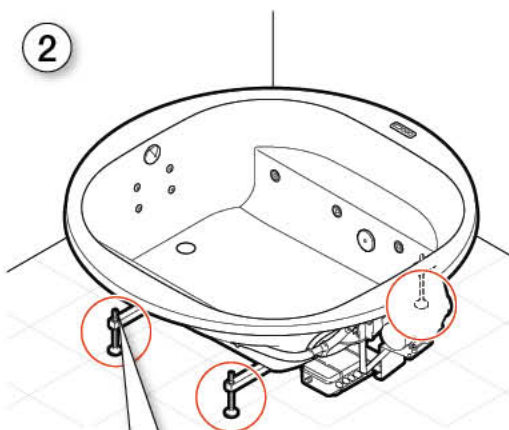

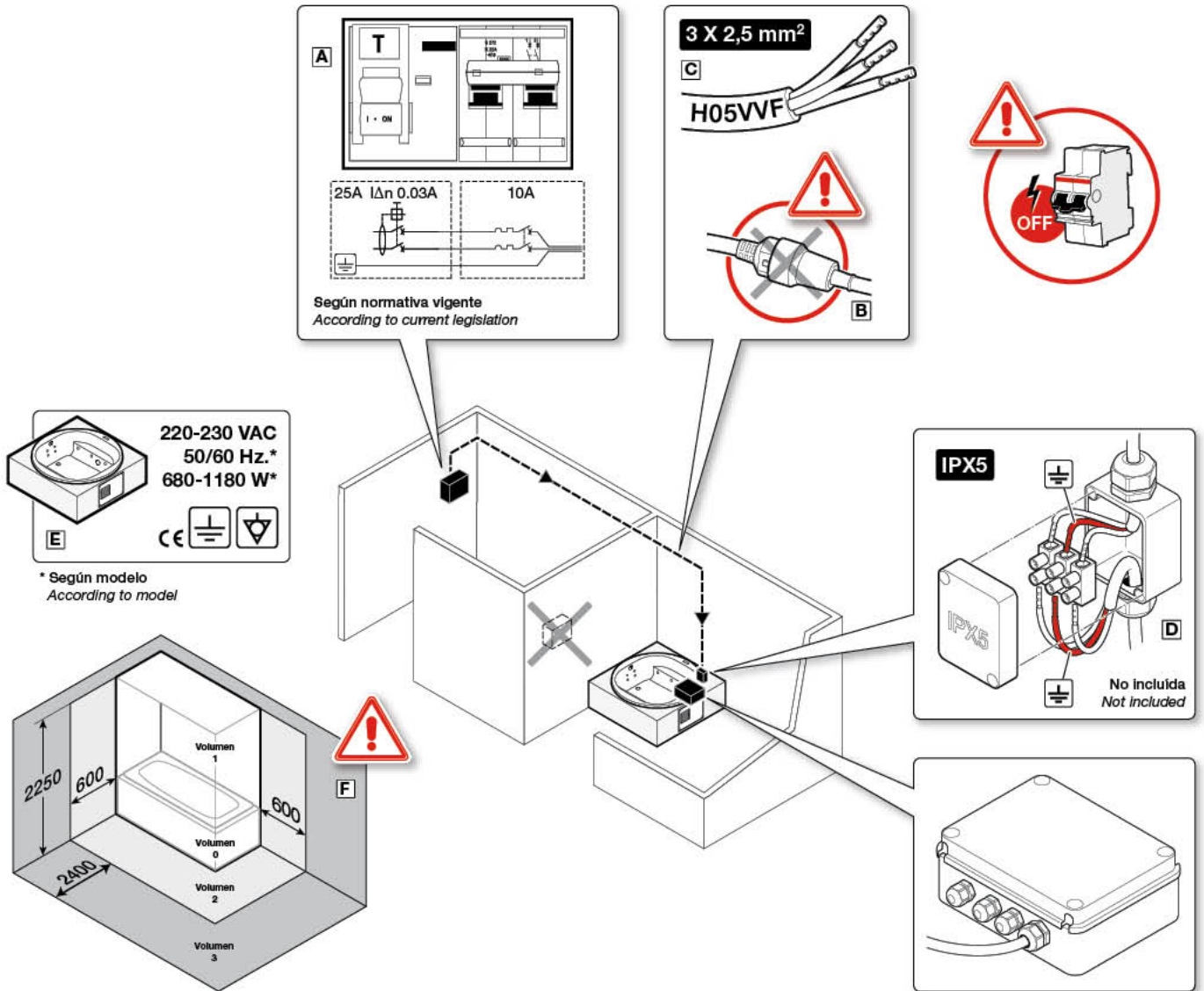

ES **A** La instalación eléctrica debe protegerse mediante un interruptor diferencial de $I_{\Delta n}$ 0,03A y 25A de potencia y de un interruptor magnetotérmico de 10A, situado fuera de los volúmenes del cuarto de baño.

B La conexión de la alimentación de este producto debe realizarse directamente a una instalación fija. No es aceptable la colocación de un enchufe.

C La línea eléctrica a instalar debe de ser de tres conductores (fase, neutro, tierra) de 2,5mm² de sección exclusivamente dedicada a la bañera. En caso de que por avería fuese necesaria la manipulación o sustitución del cable de alimentación, únicamente podrá ser realizado por el Servicio Técnico.

D La conexión a la alimentación debe realizarse en el interior de una caja eléctrica que presente un grado de protección mínimo IPX5. También debe usarse una caja de este tipo en caso de haberse de realizar un empalme de la línea de alimentación.

E La bañera debe conectarse a 230V, 50/60Hz (según modelo), a una buena toma de tierra y al borne equipotencial.

F La bañera debe de instalarse teniendo en cuenta los volúmenes de protección de forma que no haya ningún aparato eléctrico ni ninguna toma de corriente a menos de 600mm de la bañera, evitando así que una persona, dentro de la bañera, pueda llegar a tocarlo.

No se debe manipular ningún componente o conexión de la bañera.

No se debe introducir ningún aparato eléctrico dentro la bañera.

La instalación debe ser efectuada por personal cualificado, de acuerdo a la normativa nacional vigente.

EN **A** The electrical installation must be protected by means of a $I_{\Delta n}$ 0,03A and 25A differential switch and a magnetothermal switch of 10A. Both switches must be placed outside the bathroom.

B The power connection of this product must be permanently connected to a fixed electricity line. Placement of a plug is not acceptable.

C The electrical line to be installed must be consist on three drivers (phase, neutral, earth) of 2,5mm² of section exclusively dedicated to the bathtub. In the event that, due to failure, it is necessary to handle or replace the power cable, this must only be done by Technical Service staff.

D The power connection must only be done inside an electrical box with a minimal degree of protection IPX5. In case of making a junction of the electrical line must be also used a box of this type.

E The bathtub should be connected to a 230V, 50/60Hz (depending on model), supply with a good earth connection and equipotential terminal.

F The bathtub must be installed in according to the protection volumes in mind so that there is neither any electrical device nor any socket to less of 600mm of the bathtub, avoiding so a person, inside the bathtub, could manage to touch it.

Neither component nor connection of the bathtub must be operated.

No electrical device must be introduced inside the bathtub.

This product must be installed by qualified personnel, in according with the national current regulation.

5

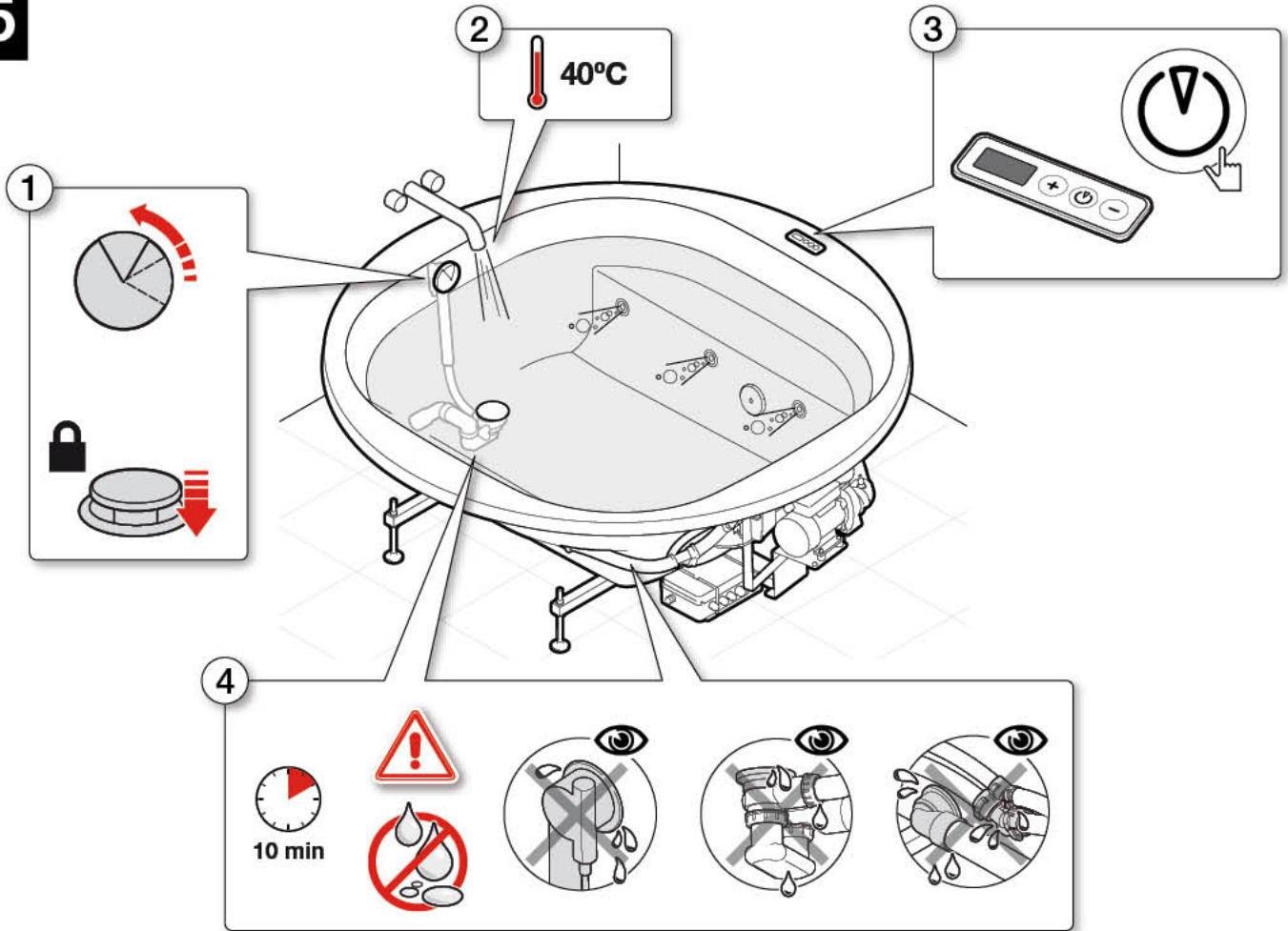

6

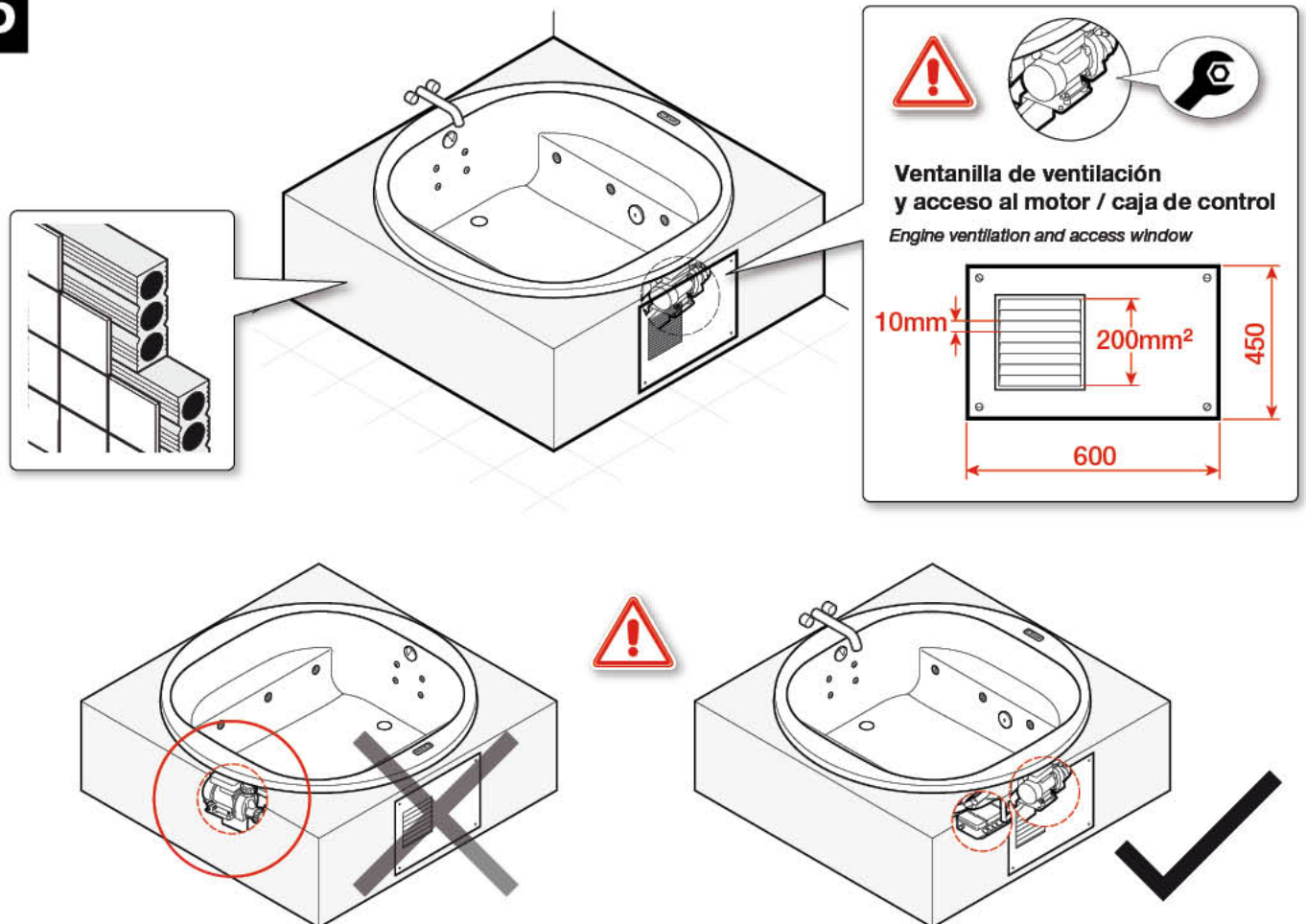

7

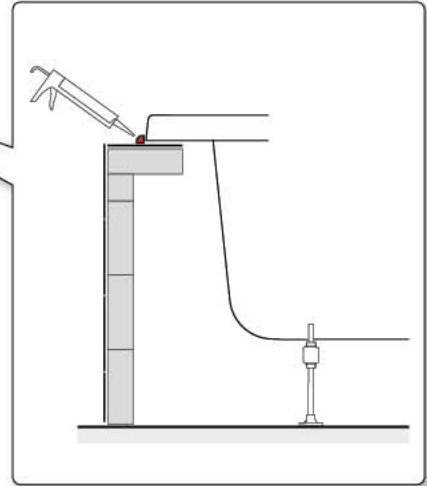
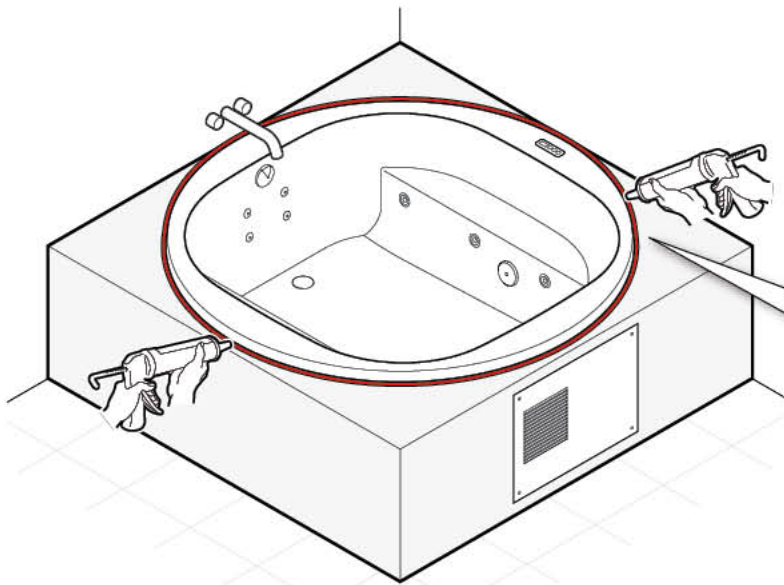

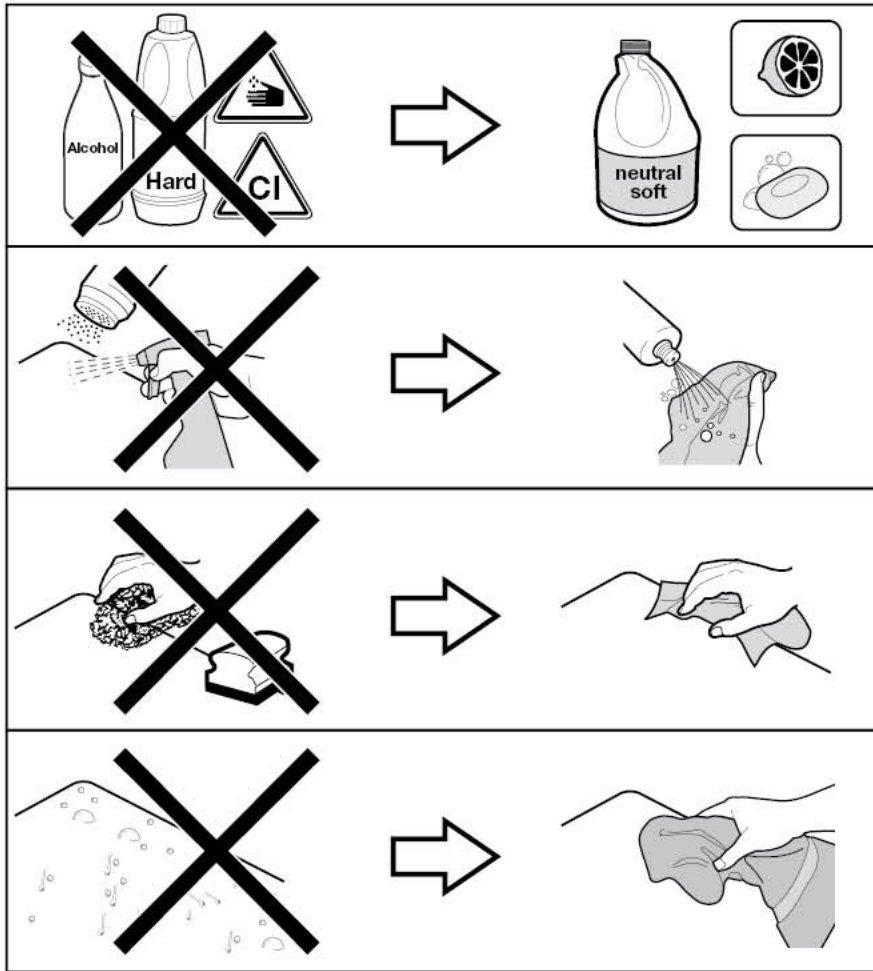

Roca Sanitario, S.A.
Avda. Diagonal, 513
08029 Barcelona
SPAIN
www.roca.com

**902
304
848** 
LÍNEA DE
ATENCIÓN AL
CONSUMIDOR
ESPAÑA

**902
400
423** 
SERVICIO
TÉCNICO
ESPAÑA

productsupport.rs@roca.net
soporteproducto.rs@roca.net