

# Modicon TM5/TM7

## I/O Safety Modules

### Hardware Guide

Original instructions

EIO0000000861.08  
02/2021

# Legal Information

The Schneider Electric brand and any trademarks of Schneider Electric SE and its subsidiaries referred to in this guide are the property of Schneider Electric SE or its subsidiaries. All other brands may be trademarks of their respective owners.

This guide and its content are protected under applicable copyright laws and furnished for informational use only. No part of this guide may be reproduced or transmitted in any form or by any means (electronic, mechanical, photocopying, recording, or otherwise), for any purpose, without the prior written permission of Schneider Electric.

Schneider Electric does not grant any right or license for commercial use of the guide or its content, except for a non-exclusive and personal license to consult it on an "as is" basis. Schneider Electric products and equipment should be installed, operated, serviced, and maintained only by qualified personnel.

As standards, specifications, and designs change from time to time, information contained in this guide may be subject to change without notice.

To the extent permitted by applicable law, no responsibility or liability is assumed by Schneider Electric and its subsidiaries for any errors or omissions in the informational content of this material or consequences arising out of or resulting from the use of the information contained herein.

©2021 Schneider Electric. All rights reserved.

# Table of Contents

Safety Information .....	7
QUALIFICATION OF PERSONNEL .....	7
INTENDED USE .....	8
Before You Begin .....	8
Start-up and Test .....	9
Operation and Adjustments .....	9
About the Book .....	10
TM5/TM7 I/O Safety Modules General Overview .....	15
Functional Safety Information .....	16
IEC 61508 and Safety Integrity Level (SIL) .....	16
Functional Safety Certification .....	16
Training .....	18
TM5/TM7 System General Rules for Implementing .....	19
Wiring Best Practices .....	19
TM5 Installation Requirements .....	23
Installation Notes .....	25
Defined Safe State and Life Span .....	26
TM5 Environmental Characteristics .....	26
TM5/TM7 Installation Guidelines .....	29
TM5/TM7 I/O Safety Modules .....	30
Presentation .....	30
TM5 Physical Description .....	33
TM7 Physical Description .....	35
Examining the Entire TM5/TM7 System According to ISO 13849 .....	38
Examining the Entire TM5/TM7 System, According to ISO 13849 .....	38
Channel Characteristics .....	39
Digital Input Channels .....	39
Filters .....	39
Error Detection .....	40
Connection Examples .....	42
Digital Output Channels .....	49
Error Detection .....	49
Connection Examples .....	50
Relay Channels .....	54
Error Detection .....	54
Connection Examples .....	55
Analog Input Channels TM5SAI4AFS Safety Module 2x2AI 4-20mA 24 Bits .....	57
Error Detection - TM5SAI4AFS Safety Module 2x2AI 4-20mA 24 Bits .....	57
Module Functions - TM5SAI4AFS Safety Module 2x2AI 4-20mA 24 Bits .....	60
Input Circuit Diagram - TM5SAI4AFS Safety Module 2x2AI 4- 20mA 24 Bits .....	61
Analog Input Channels TM5STI4ATCFS Safety Module 2x2AI Thermocouple .....	61

Error Detection - TM5STI4ATCFS Safety Module 2x2AI	
Thermocouple.....	61
Module Functions - TM5STI4ATCFS Safety Module 2x2AI	
Thermocouple.....	65
Input Circuit Diagram - TM5STI4ATCFS Safety Module 2x2AI	
Thermocouple.....	66
<b>TM5/TM7 Safety Digital Input Modules .....</b>	<b>67</b>
<b>TM5SDI2DFS Safety Module 2DI 24 Vdc Sink .....</b>	<b>68</b>
TM5SDI2DFS Presentation .....	68
TM5SDI2DFS Characteristics .....	71
TM5SDI2DFS Wiring.....	75
<b>TM5SDI4DFS Safety Module 4DI 24 Vdc Sink .....</b>	<b>76</b>
TM5SDI4DFS Presentation .....	76
TM5SDI4DFS Characteristics .....	79
TM5SDI4DFS Wiring.....	83
<b>TM5SDI20DFS Safety Module 20DI 24 Vdc Sink .....</b>	<b>84</b>
TM5SDI20DFS Presentation .....	84
TM5SDI20DFS Characteristics .....	86
TM5SDI20DFS Wiring.....	90
<b>TM7SDI8DFS Safety Module 8DI 24 Vdc .....</b>	<b>92</b>
TM7SDI8DFS Presentation .....	92
TM7SDI8DFS Characteristics .....	95
TM7SDI8DFS Wiring.....	99
<b>TM5 Safety Digital Output Modules .....</b>	<b>102</b>
<b>TM5SDO2TFS Safety Module 2DO 24 Vdc .....</b>	<b>103</b>
TM5SDO2TFS Presentation .....	103
TM5SDO2TFS Characteristics.....	106
TM5SDO2TFS Wiring .....	109
<b>TM5SDO2TAFS Safety Module 2DO 24 Vdc .....</b>	<b>110</b>
TM5SDO2TAFS Presentation .....	110
TM5SDO2TAFS Characteristics.....	113
TM5SDO2TAFS Wiring .....	117
<b>TM5SDO2DTRFS Safety Module 2DO 230 Vac/6 A, 24 Vdc/6 A .....</b>	<b>118</b>
TM5SDO2DTRFS Presentation .....	118
TM5SDO2DTRFS Characteristics .....	120
TM5SDO2DTRFS Wiring .....	125
<b>TM5SDO4TFS Safety Module 4DO 24 Vdc .....</b>	<b>126</b>
TM5SDO4TFS Presentation .....	126
TM5SDO4TFS Characteristics.....	129
TM5SDO4TFS Wiring .....	132
<b>TM5SDO4TAFS Safety Module 4DO 24 Vdc .....</b>	<b>134</b>
TM5SDO4TAFS Presentation .....	134
TM5SDO4TAFS Characteristics.....	137
TM5SDO4TAFS Wiring .....	141
<b>TM5SDO6TBFS Safety Module 6DO 24 Vdc .....</b>	<b>142</b>
TM5SDO6TBFS Presentation.....	142
TM5SDO6TBFS Characteristics .....	145
TM5SDO6TBFS Wiring .....	149
<b>TM5/TM7 Safety Digital Mixed Modules .....</b>	<b>150</b>
<b>TM5SDM4DTRFS Safety Module 2DI 2DO 48 Vac/6 A, 24 Vdc/6 A.....</b>	<b>151</b>

TM5SDM4DTRFS Presentation .....	151
TM5SDM4DTRFS Characteristics .....	154
TM5SDM4DTRFS Wiring .....	160
TM5SDM8TBFS Safety Module 6DI 2DO 24 Vdc .....	161
TM5SDM8TBFS Presentation.....	161
TM5SDM8TBFS Characteristics .....	164
TM5SDM8TBFS Wiring .....	169
TM7SDM12DTFS Safety Module 8DI 4DO 24 Vdc .....	170
TM7SDM12DTFS Presentation.....	170
TM7SDM12DTFS Characteristics .....	174
TM7SDM12DTFS Wiring .....	179
<b>TM5 Safety Analog Input Modules .....</b>	<b>182</b>
TM5SAI4AFS Safety Module 2x2AI 4-20mA 24 Bits .....	183
TM5SAI4AFS Presentation.....	183
TM5SAI4AFS Characteristics .....	186
TM5SAI4AFS Wiring .....	190
TM5STI4ATCFS Safety Module 2x2AI Thermocouple J/K/N/S/R/C/ T .....	193
TM5STI4ATCFS Presentation.....	193
TM5STI4ATCFS Characteristics .....	196
TM5STI4ATCFS Wiring .....	201
<b>TM5 Safety Counter Module .....</b>	<b>204</b>
TM5SDC1FS Safety Module DC1 7 kHz 24 Vdc Sink .....	205
TM5SDC1FS Presentation .....	205
TM5SDC1FS Characteristics .....	208
TM5SDC1FS Wiring .....	212
TM5SDC1FS Function Mode Examples.....	212
<b>TM5 Safety Power Distribution Module .....</b>	<b>218</b>
TM5SPS10FS Safety Module PS 1DO 24 Vdc .....	219
TM5SPS10FS Presentation.....	219
TM5SPS10FS Characteristics .....	225
TM5SPS10FS Wiring .....	230
<b>Appendices .....</b>	<b>231</b>
TM5ACBM3FS Safety Bus Base.....	232
TM5ACBM3FS Presentation.....	232
TM5ACBM3FS Characteristics .....	233
TM5ACBM3FS Wiring .....	234
TM5ACBM4FS Safety Bus Base.....	235
TM5ACBM4FS Presentation.....	235
TM5ACBM4FS Characteristics .....	236
TM5ACBM4FS Wiring .....	237
TM5ACTB52FS Safety Terminal Block .....	238
Safety Terminal Block Presentation .....	238
TM5ACTB5EFS Safety Terminal Block.....	241
Safety Terminal Block Presentation .....	241
TM5ACTB5FFS Safety Terminal Block .....	243
Safety Terminal Block Presentation .....	243
<b>Glossary .....</b>	<b>245</b>
<b>Index .....</b>	<b>249</b>



# Safety Information

## Important Information

Read these instructions carefully, and look at the equipment to become familiar with the device before trying to install, operate, service, or maintain it. The following special messages may appear throughout this documentation or on the equipment to warn of potential hazards or to call attention to information that clarifies or simplifies a procedure.



The addition of this symbol to a “Danger” or “Warning” safety label indicates that an electrical hazard exists which will result in personal injury if the instructions are not followed.



This is the safety alert symbol. It is used to alert you to potential personal injury hazards. Obey all safety messages that follow this symbol to avoid possible injury or death.

<b>⚠ DANGER</b>
<b>DANGER</b> indicates a hazardous situation which, if not avoided, <b>will result in</b> death or serious injury.
<b>⚠ WARNING</b>
<b>WARNING</b> indicates a hazardous situation which, if not avoided, <b>could result in</b> death or serious injury.
<b>⚠ CAUTION</b>
<b>CAUTION</b> indicates a hazardous situation which, if not avoided, <b>could result in</b> minor or moderate injury.
<b>NOTICE</b>
<b>NOTICE</b> is used to address practices not related to physical injury.

## Please Note

Electrical equipment should be installed, operated, serviced, and maintained only by qualified personnel. No responsibility is assumed by Schneider Electric for any consequences arising out of the use of this material.

A qualified person is one who has skills and knowledge related to the construction and operation of electrical equipment and its installation, and has received safety training to recognize and avoid the hazards involved.

## QUALIFICATION OF PERSONNEL

Only appropriately trained persons who are familiar with and understand the contents of this manual and all other pertinent product documentation are authorized to work on and with this product.

The qualified person must be able to detect possible hazards that may arise from parameterization, modifying parameter values and generally from mechanical, electrical, or electronic equipment. The qualified person must be familiar with the standards, provisions, and regulations for the prevention of industrial accidents, which they must observe when designing and implementing the system.

## INTENDED USE

The products described or affected by this document, together with software, accessories, and options, are expansion modules, intended for industrial use according to the instructions, directions, examples, and safety information contained in the present document and other supporting documentation.

The product may only be used in compliance with all applicable safety regulations and directives, the specified requirements, and the technical data.

Prior to using the product, you must perform a risk assessment in view of the planned application. Based on the results, the appropriate safety-related measures must be implemented.

Since the product is used as a component in an overall machine or process, you must ensure the safety of persons by means of the design of this overall system.

Operate the product only with the specified cables and accessories. Use only genuine accessories and spare parts.

Any use other than the use explicitly permitted is prohibited and can result in unanticipated hazards.

## Before You Begin

Do not use this product on machinery lacking effective point-of-operation guarding. Lack of effective point-of-operation guarding on a machine can result in serious injury to the operator of that machine.

### **▲ WARNING**

#### **UNGUARDED EQUIPMENT**

- Do not use this software and related automation equipment on equipment which does not have point-of-operation protection.
- Do not reach into machinery during operation.

**Failure to follow these instructions can result in death, serious injury, or equipment damage.**

This automation equipment and related software is used to control a variety of industrial processes. The type or model of automation equipment suitable for each application will vary depending on factors such as the control function required, degree of protection required, production methods, unusual conditions, government regulations, etc. In some applications, more than one processor may be required, as when backup redundancy is needed.

Only you, the user, machine builder or system integrator can be aware of all the conditions and factors present during setup, operation, and maintenance of the machine and, therefore, can determine the automation equipment and the related safeties and interlocks which can be properly used. When selecting automation and control equipment and related software for a particular application, you should refer to the applicable local and national standards and regulations. The National Safety Council's Accident Prevention Manual (nationally recognized in the United States of America) also provides much useful information.

In some applications, such as packaging machinery, additional operator protection such as point-of-operation guarding must be provided. This is necessary if the operator's hands and other parts of the body are free to enter the pinch points or other hazardous areas and serious injury can occur. Software products alone cannot protect an operator from injury. For this reason the software cannot be substituted for or take the place of point-of-operation protection.

Ensure that appropriate safeties and mechanical/electrical interlocks related to point-of-operation protection have been installed and are operational before placing the equipment into service. All interlocks and safeties related to point-of-



operation protection must be coordinated with the related automation equipment and software programming.

**NOTE:** Coordination of safeties and mechanical/electrical interlocks for point-of-operation protection is outside the scope of the Function Block Library, System User Guide, or other implementation referenced in this documentation.

## Start-up and Test

Before using electrical control and automation equipment for regular operation after installation, the system should be given a start-up test by qualified personnel to verify correct operation of the equipment. It is important that arrangements for such a check are made and that enough time is allowed to perform complete and satisfactory testing.

### **▲ WARNING**

#### **EQUIPMENT OPERATION HAZARD**

- Verify that all installation and set up procedures have been completed.
- Before operational tests are performed, remove all blocks or other temporary holding means used for shipment from all component devices.
- Remove tools, meters, and debris from equipment.

**Failure to follow these instructions can result in death, serious injury, or equipment damage.**

Follow all start-up tests recommended in the equipment documentation. Store all equipment documentation for future references.

#### **Software testing must be done in both simulated and real environments.**

Verify that the completed system is free from all short circuits and temporary grounds that are not installed according to local regulations (according to the National Electrical Code in the U.S.A, for instance). If high-potential voltage testing is necessary, follow recommendations in equipment documentation to prevent accidental equipment damage.

Before energizing equipment:

- Remove tools, meters, and debris from equipment.
- Close the equipment enclosure door.
- Remove all temporary grounds from incoming power lines.
- Perform all start-up tests recommended by the manufacturer.

## Operation and Adjustments

The following precautions are from the NEMA Standards Publication ICS 7.1-1995 (English version prevails):

- Regardless of the care exercised in the design and manufacture of equipment or in the selection and ratings of components, there are hazards that can be encountered if such equipment is improperly operated.
- It is sometimes possible to misadjust the equipment and thus produce unsatisfactory or unsafe operation. Always use the manufacturer's instructions as a guide for functional adjustments. Personnel who have access to these adjustments should be familiar with the equipment manufacturer's instructions and the machinery used with the electrical equipment.
- Only those operational adjustments actually required by the operator should be accessible to the operator. Access to other controls should be restricted to prevent unauthorized changes in operating characteristics.

# About the Book

## Document Scope

This manual describes the hardware implementation of the Modicon TM5/TM7 Safety I/O modules. It provides part descriptions, specifications, wiring diagrams, installation and configuration information for Modicon TM5/TM7 Safety I/O modules.

## Validity Note

This document has been updated for the release of EcoStruxure™ Machine Expert V2.0.

The technical characteristics of the devices described in the present document also appear online. To access the information online, go to the Schneider Electric home page at [www.se.com](http://www.se.com).

The characteristics that are described in the present document should be the same as those characteristics that appear online. In line with our policy of constant improvement, we may revise content over time to improve clarity and accuracy. If you see a difference between the document and online information, use the online information as your reference.

## Related Documents

Document title	Reference
Modicon TM5 Expansion Modules Configuration Programming Guide	EIO0000000420 (Eng) EIO0000000421 (Fre) EIO0000000422 (Ger) EIO0000000423 (Spa) EIO0000000424 (Ita) EIO0000000425 (Chs)
TM5SD*** Instruction Sheet	S1A85744
TM7SDI8DFS Instruction Sheet	NVE30386
TM7SDM12DTFS Instruction Sheet	S1A85745
TM5STI4ATCFS / TM5SAI4AFS Instruction Sheet	NVE30385
TM5SDC1FS Instruction Sheet	NVE30379
TM5SPS10FS Instruction Sheet	NVE30381
TM5CSLC• /TM5ACSLCM•• Instruction Sheet	S1A85742
Modicon TM7 Digital I/O Blocks Hardware Guide	EIO0000000703 (Eng) EIO0000000704 (Fre) EIO0000000705 (Ger) EIO0000000706 (Spa) EIO0000000707 (Ita) EIO0000000704 (Chs)
Modicon TM5 Safety Logic Controller SLC100/200 FS Hardware Guide	EIO0000000889 (Eng) EIO0000000890 (Fre) EIO0000000891 (Ger) EIO0000000892 (Ita)

Document title	Reference
	EIO0000000893 (Spa) EIO0000000894 (Chs)
PacDrive TM5 / TM7 Safety Flexible System, System Planning and Installation Guide	EIO0000001064 (Eng) EIO0000001066 (Ger)
Modicon TM5 / TM7 Flexible System - System Planning and Installation Guide	EIO0000000426 (Eng) EIO0000000427 (Fre) EIO0000000428 (Ger) EIO0000000430 (Ita) EIO0000000429 (Spa) EIO0000000431 (Chs)
PacDrive Logic Motion Controller LMC Pro/Pro2 Hardware Guide	EIO0000001503 (Eng) EIO0000001504 (Ger)
Operating Manual TM5 SERCOS III Bus Interface	EIO0000002367 (Eng) EIO0000002368 (Ger)
EcoStruxure Machine Expert - Safety User Guide	EIO0000002147 (Eng) EIO0000002148 (Ger)
EcoStruxure Machine Expert - Safety Safety Modules Parameters	EIO0000002265 (Eng) EIO0000002266 (Ger)

You can download these technical publications, the present document and other technical information from our website [www.se.com/en/download/](http://www.se.com/en/download/).

## Product Related Information

For important hazardous location information, refer to the individual product descriptions contained in the present document.

 **DANGER**

**HAZARD OF ELECTRIC SHOCK, EXPLOSION OR ARC FLASH**

- Disconnect all power from all equipment including connected devices prior to removing any covers or doors, or installing or removing any accessories, hardware, cables, or wires except under the specific conditions specified in the appropriate hardware guide for this equipment.
- Always use a properly rated voltage sensing device to confirm the power is off where and when indicated.
- Replace and secure all covers, accessories, hardware, cables, and wires and confirm that a proper ground connection exists before applying power to the unit.
- Use only the specified voltage when operating this equipment and any associated products.

**Failure to follow these instructions will result in death or serious injury.**

**⚠ WARNING****LOSS OF CONTROL**

- The designer of any control scheme must consider the potential failure modes of control paths and, for certain critical control functions, provide a means to achieve a safe state during and after a path failure. Examples of critical control functions are emergency stop and overtravel stop, power outage and restart.
- Separate or redundant control paths must be provided for critical control functions.
- System control paths may include communication links. Consideration must be given to the implications of unanticipated transmission delays or failures of the link.
- Observe all accident prevention regulations and local safety guidelines.<sup>1</sup>
- Each implementation of this equipment must be individually and thoroughly tested for proper operation before being placed into service.

**Failure to follow these instructions can result in death, serious injury, or equipment damage.**

<sup>1</sup> For additional information, refer to NEMA ICS 1.1 (latest edition), "Safety Guidelines for the Application, Installation, and Maintenance of Solid State Control" and to NEMA ICS 7.1 (latest edition), "Safety Standards for Construction and Guide for Selection, Installation and Operation of Adjustable-Speed Drive Systems" or their equivalent governing your particular location.

**⚠ WARNING****UNINTENDED EQUIPMENT OPERATION**

- Only use software approved by Schneider Electric for use with this equipment.
- Update your application program every time you change the physical hardware configuration.

**Failure to follow these instructions can result in death, serious injury, or equipment damage.**

**⚠ WARNING****UNINTENDED EQUIPMENT OPERATION**

- Understand the requirements contained in IEC 61508, "Functional safety of electrical/electronic/programmable electronic safety-related systems" before applying the information contained in the present document.
- Completely understand the applications and environment defined by Safety Integrity Level (SIL) 3 within IEC 61508 Parts 1-7.
- Do not exceed SIL 3 ratings in the application of this product.

**Failure to follow these instructions can result in death, serious injury, or equipment damage.**

**⚠ WARNING****POTENTIAL OF OVERHEATING AND FIRE**

- Do not connect the modules directly to line voltage.
- Use only isolating power supplies to supply power to the modules.
- Consult the present document for these products for correct voltage and current limits.

**Failure to follow these instructions can result in death, serious injury, or equipment damage.**

## Terminology Derived from Standards

The technical terms, terminology, symbols and the corresponding descriptions in this manual, or that appear in or on the products themselves, are generally derived from the terms or definitions of international standards.

In the area of functional safety systems, drives and general automation, this may include, but is not limited to, terms such as *safety*, *safety function*, *safe state*, *fault*, *fault reset*, *malfunction*, *failure*, *error*, *error message*, *dangerous*, etc.

Among others, these standards include:

Standard	Description
IEC 61131-2:2007	Programmable controllers, part 2: Equipment requirements and tests.
ISO 13849-1:2015	Safety of machinery: Safety related parts of control systems. General principles for design.
EN 61496-1:2013	Safety of machinery: Electro-sensitive protective equipment. Part 1: General requirements and tests.
ISO 12100:2010	Safety of machinery - General principles for design - Risk assessment and risk reduction
EN 60204-1:2006	Safety of machinery - Electrical equipment of machines - Part 1: General requirements
ISO 14119:2013	Safety of machinery - Interlocking devices associated with guards - Principles for design and selection
ISO 13850:2015	Safety of machinery - Emergency stop - Principles for design
IEC 62061:2015	Safety of machinery - Functional safety of safety-related electrical, electronic, and electronic programmable control systems
IEC 61508-1:2010	Functional safety of electrical/electronic/programmable electronic safety-related systems: General requirements.
IEC 61508-2:2010	Functional safety of electrical/electronic/programmable electronic safety-related systems: Requirements for electrical/electronic/programmable electronic safety-related systems.
IEC 61508-3:2010	Functional safety of electrical/electronic/programmable electronic safety-related systems: Software requirements.
IEC 61784-3:2016	Industrial communication networks - Profiles - Part 3: Functional safety fieldbuses - General rules and profile definitions.
2006/42/EC	Machinery Directive
2014/30/EU	Electromagnetic Compatibility Directive
2014/35/EU	Low Voltage Directive

In addition, terms used in the present document may tangentially be used as they are derived from other standards such as:

Standard	Description
IEC 60034 series	Rotating electrical machines
IEC 61800 series	Adjustable speed electrical power drive systems
IEC 61158 series	Digital data communications for measurement and control – Fieldbus for use in industrial control systems

Finally, the term *zone of operation* may be used in conjunction with the description of specific hazards, and is defined as it is for a *hazard zone* or *danger zone* in the *Machinery Directive (2006/42/EC)* and *ISO 12100:2010*.

**NOTE:** The aforementioned standards may or may not apply to the specific products cited in the present documentation. For more information concerning the individual standards applicable to the products described herein, see the characteristics tables for those product references.



---

# TM5/TM7 I/O Safety Modules General Overview

## What's in This Part

Functional Safety Information.....	16
TM5/TM7 System General Rules for Implementing .....	19
TM5/TM7 I/O Safety Modules.....	30
Examining the Entire TM5/TM7 System According to ISO 13849 .....	38
Channel Characteristics.....	39

# Functional Safety Information

## What's in This Chapter

IEC 61508 and Safety Integrity Level (SIL) .....	16
Functional Safety Certification .....	16
Training .....	18

## IEC 61508 and Safety Integrity Level (SIL)

### Introduction

The TM5/TM7 Safety I/O modules are a Safety-Related System certified according to IEC 61508 by TÜV Nord.

### IEC 61508 Description

The IEC 61508 is a technical standard concerning the functional safety of electrical, electronic or programmable electronic safety-related systems.

A safety-related system is a system that is required to perform one or more specific functions to ensure that risks are kept at or below an acceptable level. Such functions are defined as safety functions.

A system is defined "functionally safe" when random, systematic, and common cause equipment or machine failures do not lead to malfunctioning of the system and do not result in injury or death of humans, spills to the environment, and loss of equipment and production.

### Description of the Safety Integrity Level (SIL)

Safety-related functions are executed to achieve and maintain the defined safe state of a system. The IEC 61508 specifies four levels of safety performance for a safety-related function. These are called Safety Integrity Levels (SIL), ranging from 1 (the lowest) to 4 (the highest). The TM5/TM7 Safety I/O modules are certified for use in SIL 3 applications in which the de-energized state is the defined safe state.

## Functional Safety Certification

### Introduction

The TM5/TM7 Safety I/O modules are certified by TÜV Nord for use in applications up to SIL 3 according to IEC 61508 and IEC 62061.

This certification verifies that the TM5 and TM7 modules are compliant with the following standards:

- IEC 61508: Functional safety of electrical/electronic/programmable electronic safety-related systems, Parts 1 to 4, 2010, up to SIL 3
- ISO 13849-1: Safety of machinery - Safety-related parts of control systems - Part 1: General principles for design, 2015, up to PL e (Category 4)
- IEC 62061: Safety of machinery - Functional safety of safety-related electrical, electronic, and programmable electronic control systems, 2005 (A1:2013), up to SILcl 3

**NOTE:** Using a Safety Logic Controller equipment is a necessary but not sufficient precondition for the certification of a SIL 3 application. A SIL 3 application must also fulfill the requirements of the IEC 61508, IEC 61511, IEC 61131-2, and other application standards.



## Classification of the Schneider Electric Products

The safety-related modules allow to perform safety-related functions. However, they also support non-safety-related modules, enabling you to add non-safety parts to your SIL 3 project.

Therefore, the Schneider Electric products must be distinguished into:

- safety-related modules and
- non-safety-related modules

In contrast to the safety-modules, non-safety-related modules are not used to perform safety-related functions. They are designated as non-interfering modules for use with the Safety Logic Controller. A detected error in one of these modules does not detract the execution of the safety-related functions.

## Functional Safety Parameters

The Functional Safety parameters according to EN ISO 13849 are as follows:

- Performance Level for
  - SDI (safety-related digital input) to SDO (safety-related digital output): up to PL e
  - SAI (safety-related analog input) to SAO (safety-related analog output): up to PL e
- Category: up to 4.

## Available Safety-Related Controller

The following Schneider Electric safety-related controllers are available:

Module Type	Module Reference
Safety Logic Controller SLC 100 SERCOS III 20 nodes	TM5CSLC100FS
Safety Logic Controller SLC 200 SERCOS III 100 nodes	TM5CSLC200FS

**NOTE:** The safety-related modules must be connected by using an additional Sercos III Bus Interface TM5NS31 exclusively to the Safety Logic Controller. Mechanical, hardware, and firmware features are described in the Modicon TM5 Safety Logic Controller SLC100/200 FS Hardware Guide.

## Available Bus Interface

The following Schneider Electric bus interface is available:

Module Type	Module Reference
Sercos III Bus Interface	TM5NS31

**NOTE:** The Sercos III Bus Interface, required for communication with the Safety Logic Controller, is considered a non-interfering module and does not contribute nor detract from the safety-related function of the controller. The safety layer part of the Sercos III communication is managed inside the safety-related modules and not in the Sercos III Bus Interface.

For more information on safety-related product architectures, refer to the PacDrive TM5 / TM7 Safety Flexible System, System Planning and Installation Guide.

**⚠ DANGER****IMPROPER SAFETY-RELATED SYSTEM**

- Use only modules designated as safety-related modules to perform safety-related functions.
- Make sure that neither inputs nor outputs of non-safety-related modules are used for safety-related functions.

**Failure to follow these instructions will result in death or serious injury.**

## Probabilities of Failure

For SIL 3 applications, IEC 61508 defines the following probabilities of failure on demand (PFD) and probabilities of failure per hour (PFH) depending on the mode of operation:

- $PFD \geq 10^{-4}$  to  $< 10^{-3}$  for low demand mode of operation
- $PFH \geq 10^{-8}$  to  $< 10^{-7}$  for high demand mode of operation

## Training

### Introduction

As stated in the IEC 61508, Part 1, App. B, all persons involved in a Safety Lifecycle activity must have the appropriate training, technical knowledge, experience, and qualifications relevant apply the products specified in the present document. Training, technical knowledge, experience, and qualifications should be assessed in relation to each particular application.

**NOTE:** Make sure you possess all information and skills required to install, run, and maintain Safety-Related Systems correctly.

# TM5/TM7 System General Rules for Implementing

## What's in This Chapter

Wiring Best Practices..... 19  
 TM5 Installation Requirements ..... 23  
 Installation Notes..... 25  
 Defined Safe State and Life Span ..... 26  
 TM5 Environmental Characteristics ..... 26  
 TM5/TM7 Installation Guidelines ..... 29

## Wiring Best Practices

### Introduction

There are several rules that must be followed when wiring the TM5/TM7 System.

### Wiring Rules

**⚠️ ⚠️ DANGER**

**HAZARD OF ELECTRIC SHOCK, EXPLOSION OR ARC FLASH**

- Disconnect all power from all equipment including connected devices prior to removing any covers or doors, or installing or removing any accessories, hardware, cables, or wires except under the specific conditions specified in the appropriate hardware guide for this equipment.
- Always use a properly rated voltage sensing device to confirm the power is off where and when indicated.
- Replace and secure all covers, accessories, hardware, cables, and wires and confirm that a proper ground connection exists before applying power to the unit.
- Use only the specified voltage when operating this equipment and any associated products.

**Failure to follow these instructions will result in death or serious injury.**

The following rules must be applied when wiring the system:

- I/O and communication wiring must be kept separate from the power wiring. Route these 2 types of wiring in separate cable ducts.
- Verify that the operating conditions and environment are within the specification values.
- Use proper wire sizes to meet voltage and current requirements.
- Use copper conductors only.
- In the case of TM5 Safety I/O modules:
  - Use twisted-pair, shielded cables for safety-related I/O and TM5 bus signals.
  - Use twisted-pair, shielded cables for encoder, networks and field bus (Sercos III).
- In the case of TM7 Safety I/O modules:
  - Use only the expansion bus and I/O cables specifically designed for TM7 I/O.

## TM5 Safety I/O Wiring

### ⚠ WARNING





#### UNINTENDED EQUIPMENT OPERATION

- Use shielded cables for safety-related I/O and communication signals.
- Ground cable shields for safety-related I/O and communication signals at a single point<sup>1</sup>.
- Route communications and I/O cables separately from power cables.





**Failure to follow these instructions can result in death, serious injury, or equipment damage.**

<sup>1</sup>Multipoint grounding is permissible (and in some cases inevitable) if connections are made to an equipotential ground plane dimensioned to help avoid cable shield damage in the event of power system short-circuit currents.

Wire sizes to use with the removable spring terminal block TM5ACTB52FS:

$\frac{\text{mm}}{\text{in.}}$ 				
mm <sup>2</sup>	0,08...2,5	0,25...2,5	0,25...1,5	2 x 0,25...2 x 0,75
AWG	28...14	24...14	24...16	2 x 24...2 x 18

Wire sizes to use with the removable spring terminal blocks TM5ACTB5EFS and TM5ACTB5FFS:

$\frac{\text{mm}}{\text{in.}}$ 			
mm <sup>2</sup>	0,08...1,5	0,25...1,5	0,25...0,75
AWG	28...16	24...16	24...20

The spring clamp connectors of the terminal block are designed for only one wire or one cable end. Two wires to the same connector must be installed with a double wire cable end to help prevent loosening.

### ⚡⚠ DANGER

#### LOOSE WIRING CAUSES ELECTRIC SHOCK

Do not insert more than one wire per connector of the spring terminal blocks unless using a double wire cable end (ferrule).

**Failure to follow these instructions will result in death or serious injury.**

### ⚠ DANGER

#### FIRE HAZARD

Use only the correct wire sizes for the maximum current capacity of the I/O channels and power supplies.

**Failure to follow these instructions will result in death or serious injury.**

## TM5 Terminal Block

Inserting an incorrect terminal block into the electronic module can cause unintended operation of the application and/or damage the electronic module.

**⚠ DANGER**

**INCORRECT TERMINAL BLOCK WIRING**

Be sure to connect the correct terminal blocks to their designated location.

**Failure to follow these instructions will result in death or serious injury.**

**NOTE:** To help prevent a terminal block from being inserted incorrectly, ensure that each terminal block and electronic module is clearly and uniquely coded.

### TM5 Strain Relief Using Cable Tie

There are two methods to reduce the strain on cables:

- The terminal blocks have slots to attach cable ties. A cable tie can be fed through this slot to secure cables and wires to reduce stress between them and the terminal block connections.
- After grounding the TM5 System by means of the grounding plate TM2XMTGB, wires can be bundled and affixed to the grounding plate tabs using wire ties to reduce stress on the cables.

The following table provides the size of the cable tie and presents the two methods to reduce the stress on the cables:

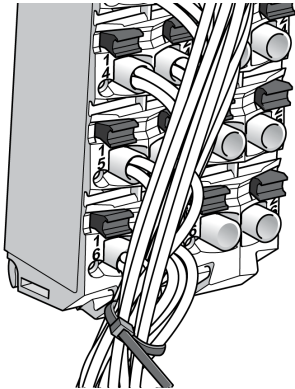
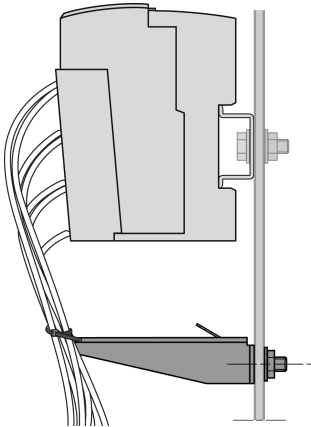
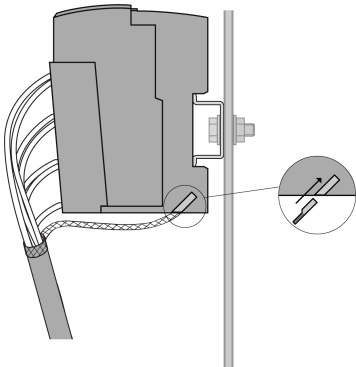
Cable Tie Size	Terminal block	TM2XMTGB Grounding plate	TM5 Grounding connector
Thickness	1.2 mm (0.05 in.) maximum	1.2 mm (0.05 in.)	1.2 mm (0.05 in.)
Width	4 mm (0.16 in.) maximum	2.5...3 mm (0.1...0.12 in.)	2.5...3 mm (0.1...0.12 in.)
Mounting graphic			 <p>Twist the shielded cables and connect them with a cable lug (2.8 x 0.5 mm / 0.11 x 0.02 in.) to the grounding connector of the TM5 Safety I/O modules.</p> <p><b>NOTE:</b> Make sure that this grounding connection is short and of low resistance.</p>

Also refer to Grounding the System (see PacDrive TM5 / TM7 Safety Flexible System, System Planning and Installation Guide).

### TM7 Safety I/O Wiring

The TM7 System blocks, when using Schneider Electric IP67 pre-fabricated cables, incorporate a grounding system intrinsic to the mounting and connecting hardware. The TM7 System blocks must always be mounted on a conductive backplane. The backplane or object used for mounting the blocks (metal machine frame, mounting rail or mounting plate) must be grounded (PE) according to your local, regional and national requirements and regulations. For more important

information, refer to grounding of your system blocks (see PacDrive TM5 / TM7 Safety Flexible System, System Planning and Installation Guide).

**NOTE:** If you do not use Schneider Electric IP67 pre-fabricated cables, you must use shielded cables and conductive connectors (metal threads on the connector), and be sure to connect the cable shield to the metal sleeve of the connector.

## ⚠ WARNING

### IMPROPER GROUNDING CONTINUITY

- Use only cables with insulated, shielded jackets.
- Use only IP67 connectors with metal threads.
- Connect the cable shield to the metal threads of the connectors.
- Always comply with local, regional and/or national wiring requirements.

**Failure to follow these instructions can result in death, serious injury, or equipment damage.**

The following figure presents the grounding of the TM7 System:

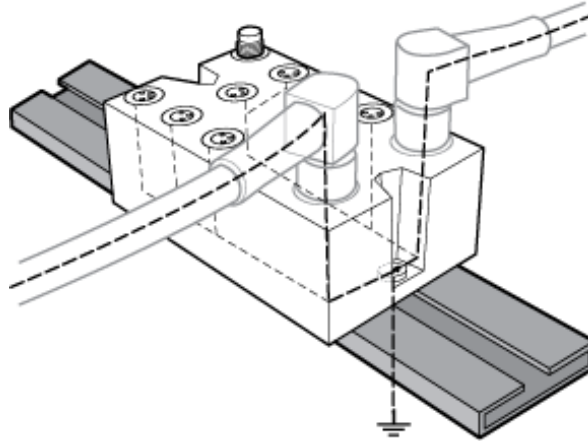

## Protecting Outputs from Inductive Load Damage

Depending on the load, a protection circuit may be needed for the outputs on the controllers and certain modules. Inductive loads using DC voltages may create voltage reflections resulting in overshoot that will damage or shorten the life of output devices.

## ⚠ WARNING

### INDUCTIVE LOADS

Use an appropriate external protective circuit or device to reduce the risk of inductive direct current load damage.

**Failure to follow these instructions can result in death, serious injury, or equipment damage.**

Relay outputs can support up to 48 Vac (TM5SDM4DTRFS) and up to 230 Vac (TM5SDO2DTRFS). Inductive damage to these types of outputs can result in welded contacts and loss of control. Each inductive load must be equipped with a protection device such as a peak limiter, RC circuit or flyback diode. Capacitive loads are not supported by these relays.

## ⚠ WARNING

### RELAY OUTPUTS WELDED CLOSED

- Always protect relay outputs from inductive alternating current load damage using an appropriate external protective circuit or device.
- Do not connect relay outputs to capacitive loads.

**Failure to follow these instructions can result in death, serious injury, or equipment damage.**

Protective circuit A: this protection circuit can be used for both AC and DC load power circuits.

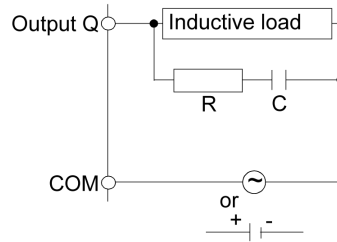

- C represents a value from 0.1 to 1  $\mu$ F.
- R represents a resistor of approximately the same resistance value as the load.

Protective circuit B: this protection circuit can be used for DC load power circuits.

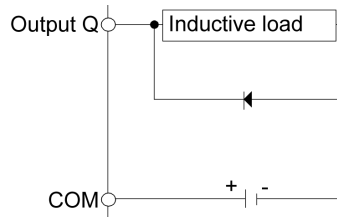

Use a diode with the following ratings:

- Reverse withstand voltage: power voltage of the load circuit x 10.
- Forward current: more than the load current.

Protective circuit C: this protection circuit can be used for both AC and DC load power circuits.

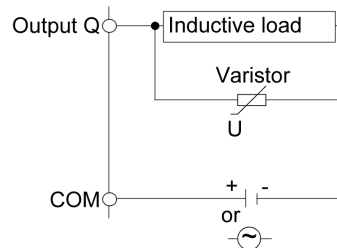

- In applications where the inductive load is switched on and off frequently and/or rapidly, ensure that the continuous energy rating (J) of the varistor exceeds the peak load energy by 20 % or more.

## TM5 Installation Requirements

### Before Starting

Read and understand this chapter before beginning the installation of your TM5 System.

**⚡⚠ DANGER****HAZARD OF ELECTRIC SHOCK, EXPLOSION OR ARC FLASH**

- Disconnect all power from all equipment including connected devices prior to removing any covers or doors, or installing or removing any accessories, hardware, cables, or wires except under the specific conditions specified in the appropriate hardware guide for this equipment.
- Always use a properly rated voltage sensing device to confirm the power is off where and when indicated.
- Replace and secure all covers, accessories, hardware, cables, and wires and confirm that a proper ground connection exists before applying power to the unit.
- Use only the specified voltage when operating this equipment and any associated products.

**Failure to follow these instructions will result in death or serious injury.**

**NOTICE****ELECTROSTATIC DISCHARGE**

- Store all components in their protective packaging until immediately before assembly.
- Never touch exposed conductive parts such as contacts or terminals.

**Failure to follow these instructions can result in equipment damage.**

**Programming Considerations****⚠ WARNING****UNINTENDED EQUIPMENT OPERATION**

- Only use software approved by Schneider Electric for use with this equipment.
- Update your application program every time you change the physical hardware configuration.

**Failure to follow these instructions can result in death, serious injury, or equipment damage.**

**Operating Environment**

For important hazardous location information, refer to the individual product descriptions contained in the present document.

**⚠ WARNING****UNINTENDED EQUIPMENT OPERATION**

Install and operate this equipment according to the conditions described in the Environmental Characteristics.

**Failure to follow these instructions can result in death, serious injury, or equipment damage.**



## Installation Considerations

<b>▲ WARNING</b>
<p><b>UNINTENDED EQUIPMENT OPERATION</b></p> <ul style="list-style-type: none"> <li>• Use appropriate safety interlocks where personnel and/or equipment hazards exist.</li> <li>• Install and operate this equipment in an enclosure appropriately rated for its intended environment and secured by a keyed or tooled locking mechanism.</li> <li>• Use the sensor and actuator power supplies only for supplying power to the sensors or actuators connected to the module.</li> <li>• Power line and output circuits must be wired and fused in compliance with local and national regulatory requirements for the rated current and voltage of the particular equipment.</li> <li>• Do not use this equipment in safety-critical machine functions unless the equipment is otherwise designated as functional safety equipment and conforming to applicable regulations and standards.</li> <li>• Do not disassemble, repair, or modify this equipment.</li> <li>• Do not connect any wiring to reserved, unused connections, or to connections designated as No Connection (N.C.).</li> </ul> <p><b>Failure to follow these instructions can result in death, serious injury, or equipment damage.</b></p>

## Installation Notes

### Installation Notes

Products must be protected against dirt and grime. TM5 Safety I/O modules are protected from dirt and grime up to Pollution Level II in the IEC 60664 standard.

TM5 Safety I/O modules should be installed in IP54 rated cabinets to help protect the modules from hazardous pollution levels. Pollution levels greater than specified by Pollution Level II in the IEC 60664 standard can result in unreliable operation of the equipment.

<b>▲ WARNING</b>
<p><b>UNINTENDED EQUIPMENT OPERATION</b></p> <p>Ensure that TM5 safety modules are installed in proper operating environment.</p> <p><b>Failure to follow these instructions can result in death, serious injury, or equipment damage.</b></p>

<b>▲ WARNING</b>
<p><b>UNINTENDED EQUIPMENT OPERATION</b></p> <p>Use an isolating power supply that conforms to IEC 60204 for the TM5 bus, safety-related I/O and Safety Logic Controller supplies.</p> <p><b>Failure to follow these instructions can result in death, serious injury, or equipment damage.</b></p>

## Defined Safe State and Life Span

### Defined Safe State

If the module detects an internal error or a wiring error, the modules enable the defined safe state. The defined safe state is structurally designed as a low state or de-energized state and can not be modified.

For more information regarding error detection, refer to the sections *Error Detection* in the chapter *Channel Characteristics*, page 39.

In circumstances where external influences may be present such that a de-energized state would require the application to actively turn on an actuator, additional measures such as mechanical brakes may be necessary to help prevent hazard from materializing.

### **▲ WARNING**

#### **UNINTENDED EQUIPMENT OPERATION**

Be sure to include in your risk assessment the effect on all systems when the defined safe state differentially removes power from elements of your machine or process.

**Failure to follow these instructions can result in death, serious injury, or equipment damage.**

### Life span

The Safety I/O modules have a maximum expected life span of 20 years when applied and maintained according to the user instructions.

This means that the Safety I/O modules must be taken out of service one week (at the latest) before the expiration of this 20-year life span (starting from delivery date).

### **NOTICE**

#### **EQUIPMENT DAMAGE**

- Do not operate the Safety I/O modules beyond the specified life span.
- Ensure that the Safety I/O modules are removed from operation, and replaced by new Safety I/O modules, before their life span expires.

**Failure to follow these instructions can result in equipment damage.**

## TM5 Environmental Characteristics

### Introduction

The following information describes the system-wide environmental requirements and characteristics for the TM5 System.

The general environmental characteristics are common to all components of the TM5 System.

### Enclosure Requirements

TM5 components are designed as Zone B, Class A industrial equipment according to IEC/CISPR Publication 11. If they are used in environments other than those described in the standard, or in environments that do not meet the specifications in this manual, your ability to meet electromagnetic compatibility

requirements in the presence of conducted and/or radiated interference may be reduced.

All TM5 components meet European Community (CE) requirements for open equipment as defined by EN61131-2. You must install them in an enclosure designed for the specific environmental conditions and to minimize the possibility of unintended contact with hazardous voltages. Your enclosure should be constructed of metal to improve the electromagnetic immunity of your TM5 System. Your enclosure should have a keyed locking mechanism to minimize unauthorized access.

### Environmental Characteristics

This equipment meets UL, CSA, and CE requirements as indicated in the following table. This equipment is intended for use in a Pollution Degree 2 industrial environment.

The following table provides the general environmental characteristics:

Characteristic	Specification	
Standard	IEC61131-2	
Agencies	UL508, CSA 22.2 n° 142	
Ambient operating temperature	Horizontal installation	0...55 °C (32...131 °F) <sup>(1)</sup>
	Vertical installation	0...50 °C (32...122 °F)
Storage temperature	- 25...70 °C (- 13...158 °F)	
Relative humidity	5...95% (non-condensing)	
Degree of pollution	IEC60664	2
Degree of protection	IEC61131-2	IP20
Corrosion immunity	No	
Operating altitude	0 up to 2,000 m (0 up to 6,560 ft.)	
Storage altitude	0 up to 3,000 m (0 up to 9,842 ft.)	
Vibration resistance	Mounted on a DIN rail	3.5 mm (0.138 in.) fixed amplitude from 5...8.4 Hz
		9.8 m/s <sup>2</sup> (1 g <sub>n</sub> ) fixed acceleration from 8.4...150 Hz
Mechanical shock resistance	147 m/s <sup>2</sup> (15 g <sub>n</sub> ) for a duration of 11 ms	
Connection type	Removable spring terminal block	
Connector insertion/removal cycles	50	
<p><b>(1)</b> Some devices have temperature operating restrictions that require de-rating between 55 °C and 60 °C (131 °F and 140 °F), and may be subject to other possible restrictions. Refer to the specific characteristics for your electronic module.</p>		

### Electromagnetic Susceptibility

The following table provides the TM5 System electromagnetic susceptibility specifications:

Characteristic	Specification	Range
Electrostatic discharge	IEC/EN 61000-4-2	8 kV (air discharge), criteria B 4 kV (contact discharge), criteria B
Electromagnetic fields	IEC/EN 61000-4-3	10 V/m (80 MHz...2 GHz), criteria A
Fast transients burst	IEC/EN 61000-4-4	Power lines: 2 kV, criteria B
		I/O: 1 kV, criteria B
		Shielded cable: 1 kV, criteria B

Characteristic	Specification	Range
		Repetition rate: 5 and 100 KHz
Surge immunity 24 Vdc circuit	IEC/EN 61000-4-5	1 kV in common mode, criteria B 0.5 kV in differential mode, criteria B
Surge immunity 230 Vac circuit		2 kV in common mode, criteria B 1 kV in differential mode, criteria B
Induced electromagnetic field	IEC/EN 61000-4-6	10 V <sub>eff</sub> (0.15...80 MHz), criteria A
Conducted emission	EN 55011 (IEC/CISPR11)	150...500 kHz, quasi peak 79 dB (μV)
		500 kHz...30 MHz, quasi peak 73 dB (μV)
Radiated emission	EN 55011 (IEC/CISPR11)	30...230 MHz, 10 m@40 dB (μV/m)
		230 MHz...1 GHz, 10 m@47 dB (μV/m)
<b>Criteria A</b> Uninterrupted operation during test.		
<b>Criteria B</b> Brief interruption during the test allowed.		

## Electromagnetic Susceptibility according to IEC 62061

The following table provides the TM5 System electromagnetic susceptibility specifications (according to IEC 62061):

Connection	Characteristic	Specification	Range
Housing	Electrostatic discharge (ESD) <sup>(1)</sup>	IEC 61000-4-2	6 kV/ 8 kV (contact-/air discharge)
	High-frequency electromagnetic (EM) fields	IEC 61000-4-3	20 V/m (80 MHz...1 GHz) 6 V/m (1.4...2 GHz) 3 V/m (2...2.7 GHz) <sup>(2)</sup>
	Magnetic field with electrical frequency <sup>(3)</sup>	IEC 61000-4-8	30 A/m <sup>(4)</sup>
AC supply	Voltage dips / Short-term interruptions	IEC 61000-4-11	0.5 period 30% reduction <sup>(4)</sup>
	Voltage fluctuations /Interruptions	IEC 61000-4-11	250 periods, > 95% reduction <sup>(4)</sup>
	High-speed transient electrical disturbances (burst)	IEC 61000-4-4	4 kV
	Surges <sup>(5)</sup>	IEC 61000-4-5	2 kV line to line / 4 kV grounding line
	Line-conducted disturbances, induced by high-frequency fields	IEC 61000-4-6	10 V in the specified frequencies <sup>(2)</sup>
DC supply <sup>(6)</sup>	High-speed transient electrical disturbances (burst)	IEC 61000-4-4	4 kV
	Surges	IEC 61000-4-5	1 kV line to line / 2 kV grounding line <sup>(5)</sup>
	Line-conducted disturbances, induced by high-frequency fields	IEC 61000-4-6	10 V in the specified frequencies <sup>(2)</sup>
I/O signal control lines	High-speed transient electrical disturbances (burst)	IEC 61000-4-4	2 kV for > 3 m lines
	Surges	IEC 61000-4-5	2 kV grounding line <sup>(7)</sup>
	Line-conducted disturbances, induced by high-frequency fields	IEC 61000-4-6	10 V <sup>(2)</sup>

Connection	Characteristic	Specification	Range
Functional ground (earth)	High-speed transient electrical disturbances (burst)	IEC 61000-4-4	2 kV
<p>(1) Strict adherence to environmental conditions described in IEC 61000-4-2 is necessary for parts handled by persons other than operating personnel with specific ESD (electrostatic discharge) control operations. However, this is not valid for equipment with limited access by properly trained personal only.</p> <p>(2) The increased values must be implemented in frequency areas generally used for digital radio transmission, excluding areas where reliable measures are taken to reduce the electromagnetic influence of such equipment. ISM frequencies must be individually observed.</p> <p>(3) For magnetically sensitive equipment only.</p> <p>(4) An increased value is not used on phenomena where it is not considered necessary for the functional safety.</p> <p>(5) External protection devices are allowed in order to achieve immunity.</p> <p>(6) DC connections between system/equipment parts that are not connected with a DC distributing network are handled as I/O signal/control connections.</p> <p>(7) Only in the case of long lines.</p>			

## TM5/TM7 Installation Guidelines

### Installation

For information concerning the installation requirements such as spacing and clearances, electronic modules and accessories installation, and product labeling, refer to PacDrive TM5 / TM7 Safety Flexible System, System Planning and Installation Guide.

# TM5/TM7 I/O Safety Modules

## What's in This Chapter

Presentation ..... 30  
 TM5 Physical Description..... 33  
 TM7 Physical Description..... 35

## Presentation

### General Information

Digital and analog I/O modules convert process signals into the internal signal level required by the controller.

The TM5/TM7 Safety I/O modules can be used in safety-related applications according to:

- EN ISO 13849, up to PL e
- IEC 62061, up to SIL 3
- IEC 61508, up to SIL 3

### Safety Digital Input Modules

The following table presents an overview of the safety digital input modules:

Module	TM5SDI2DFS, page 68	TM5SDI4DFS, page 76	TM5SDI20DFS, page 84	TM7SDI8DFS, page 92
Number of safety-related inputs	2	4	20	8
Number of non-safety-related inputs	-	-	-	2
Number of safety-related test outputs	2	4	4	2
Number of non-safety-related outputs	-	-	-	2
Rated input/output voltage	24 Vdc			
Input filter: Hardware Software	maximum 150 µs Default 0 ms, can be configured 0...500 ms			
Safety terminal block	TM5ACTB52FS			-
Safety bus base	TM5ACBM3FS			-

### Safety Digital Output Modules

The following tables present an overview of the safety digital output modules:

Module	TM5SDO2TFS, page 103	TM5SDO2TAFS, page 110	TM5SDO4TFS, page 126	TM5SDO4TAFS, page 134	TM5SDO6TBFS, page 142
Number of safety-related outputs	2	2	4	4	6
Rated output voltage	24 Vdc				
Rated output current	0.5 A	2.0 A	0.5 A	2.0 A	0.2 A
Total current	1.0 A	4.0 A	2.0 A	5.0 A	1.2 A
Output protection	Integrated over-current protection and inductive load resistance				

Module	TM5SDO2TFS, page 103	TM5SDO2TAFS, page 110	TM5SDO4TFS, page 126	TM5SDO4TAFS, page 134	TM5SDO6TBFS, page 142
Safety terminal block	TM5ACTB52FS				
Safety bus base	TM5ACBM3FS				

Safety Relay Output module:

Module	TM5SDO2DTRFS, page 118
Number of safety-related outputs	2 relays, normally open contacts
Switching voltage range	5...24 Vdc, 5...230 Vac
Switching current range	5 mA...6 A
Total current	5 mA...6 A
Overload protection and short circuit protection	None: External maximum 6 A gL/gG fuse (filament fuse) required
Safety terminal block	TM5ACTB52FS
Safety bus base	TM5ACBM3FS

### Safety Digital Mixed Modules

The following table presents an overview of the safety digital mixed modules:

Module	TM5SDM4DTRFS, page 151	TM5SDM8TBFS, page 161	TM7SDM12DTFS, page 170
Number of safety-related inputs	2	6	8
Rated input voltage	24 Vdc		
Input filter: Hardware Software	maximum 150 µs Default 0 ms, can be configured 0...500 ms		
Number of safety-related outputs	2 relay outputs	2 FET outputs	4 FET outputs
Output voltage range	5...24 Vdc, 5...48 Vac	24 Vdc	24 Vdc
Output current range	5 mA...6 A	500 mA	2 A
Total current	5 mA...6 A	1 A	5 A
Number of safety-related test outputs	2	6	8
Safety terminal block	TM5ACTB52FS	TM5ACTB5FFS	-
Safety bus base	TM5ACBM3FS		

### Safety Analog Input Modules

The following table presents an overview of the safety analog input modules:

Module	TM5SAI4AFS, page 183	TM5STI4ATCFS, page 193
Number of inputs	2 redundant safety-related analog inputs	2 redundant safety-related analog inputs for thermocouples
Input filter	Configurable input filter and switching threshold	
Input range	<ul style="list-style-type: none"> <li>4...20 mA (valid measurement range)</li> <li>0.5...25 mA (input range)</li> </ul>	-65...+65 mV (voltage measurement range)
Thermocouple measurement range	-	-270...1768 °C (-454...3214.4 °F)

Module	TM5SAI4AFS, page 183	TM5STI4ATCFS, page 193
		Refer to <i>TM5STI4ATCFS Presentation</i> , page 193.
Input sensor type	-	J, K, N, S, R, C, T Thermocouple sensors
Terminal temperature compensation	-	2 non-redundant safety-related analog inputs for PT100/PT1000 measurement
Digital converter resolution	24 bits	
Safety terminal block	TM5ACTB5FFS	TM5ACTB5EFS or TM5ACTB5FFS
Safety bus base	TM5ACBM3FS	

## Safety Counter Module

The following table presents an overview of the Safety Counter module:

Module	TM5SDC1FS, page 205
Number of inputs	1 safety-related input counter channel
Rated input voltage	24 Vdc
Input filter	Configurable input filter
Maximum input frequency	7 kHz
Function modes	A-A, A-B, A-A/-B-B/
Safety terminal block	TM5ACTB52FS
Safety bus base	TM5ACBM3FS

## Safety Power Distribution Module

The following table presents an overview of the Safety Power Distribution module:

Module	TM5SPS10FS, page 219
Number of safety-related outputs	1 redundant safety-related digital FET output with current monitoring
Rated output voltage	24 Vdc
Rated output current	10 A
Rated voltage to the I/O power segment bus	24 Vdc
Rated output current to the I/O power segment bus	10 A
Total current	10 A
Output protection	Integrated over-current protection and inductive load resistance
Safety terminal block	TM5ACTB52FS
Safety bus base	TM5ACBM4FS

### **⚠ WARNING**

#### **UNINTENDED EQUIPMENT OPERATION**

Use an isolating power supply that conforms to IEC 60204 for the TM5 bus, safety-related I/O and Safety Logic Controller supplies.

**Failure to follow these instructions can result in death, serious injury, or equipment damage.**



# TM5 Physical Description

## Introduction

Each slice consists of three elements. These elements are a red Safety bus base, a red electronic Safety I/O module, and a red Safety terminal block.

<p><b>⚠️⚠️ DANGER</b></p> <p><b>INCOMPATIBLE COMPONENTS CAUSE ELECTRIC SHOCK OR ARC FLASH</b></p> <ul style="list-style-type: none"> <li>• Do not associate components of a slice that have different colors.</li> <li>• Verify that correct terminal blocks (minimally, matching colors and correct number of terminals) are installed on the appropriate electronic modules.</li> </ul> <p><b>Failure to follow these instructions will result in death or serious injury.</b></p>
--

## Elements

The following figure presents the elements of a slice:

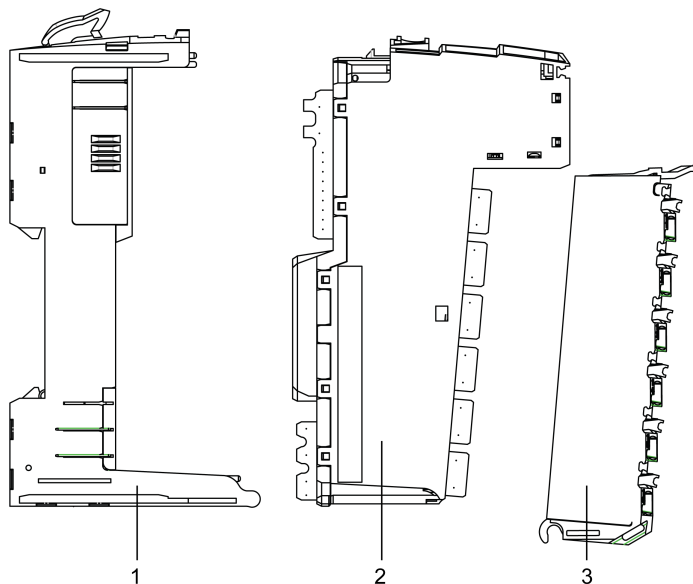

1. Safety bus base
2. Electronic Safety I/O module
3. Safety terminal block

When assembled, the three components form an integral unit that resists vibration.

<p><b>NOTICE</b></p> <p><b>ELECTROSTATIC DISCHARGE</b></p> <ul style="list-style-type: none"> <li>• Never touch the pin connectors of the block.</li> <li>• Always keep the cables or sealing plugs in place during normal operation.</li> </ul> <p><b>Failure to follow these instructions can result in equipment damage.</b></p>
---

## Dimensions

The following figure presents the dimensions of a slice:

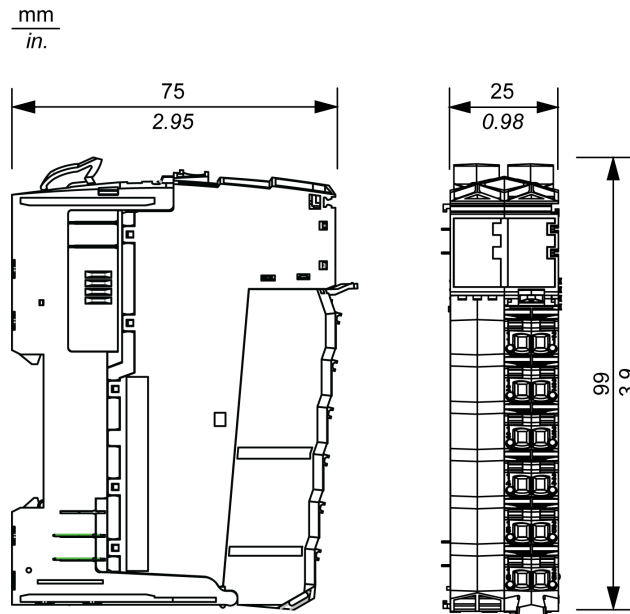

## Safety Bus Bases

For a detailed description of the Safety bus base, refer to:

- TM5ACBM3FS Safety bus base, page 232
- TM5ACBM4FS Safety bus base, page 235

## Safety terminal block Pin Assignment

The following figure presents the pin assignments for the Safety terminal block:

TM5ACTB52FS	TM5ACTB5EFS	TM5ACTB5FFS
<p>For a detailed description, refer to:</p> <ul style="list-style-type: none"> <li>• TM5ACTB52FS Safety terminal block, page 238</li> <li>• TM5ACTB5EFS Safety terminal block, page 241</li> <li>• TM5ACTB5FFS Safety terminal block, page 243</li> </ul>		

### Accessories

Refer to PacDrive TM5 / TM7 Safety Flexible System, System Planning and Installation Guide.

### Labeling

Refer to PacDrive TM5 / TM7 Safety Flexible System, System Planning and Installation Guide.

## TM7 Physical Description

### Introduction

The TM7 System consists of IP67 I/O blocks along with field bus, expansion, sensor/actuator and power cables.

### General View of a TM7 I/O Block and Cables

The following figure presents a TM7 I/O block and associated cables:

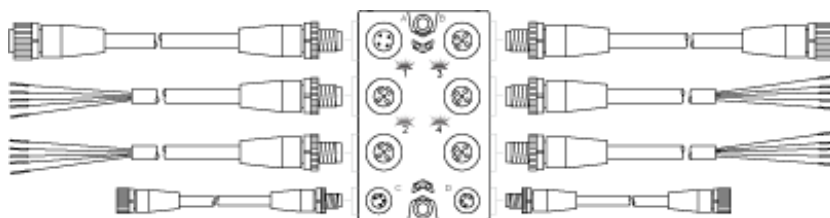

Item	TM7 Cable Type	TM7 Block Connector
A	Expansion bus drop cable	TM7 bus IN
B	Expansion bus drop cable	TM7 bus OUT
1...4	Sensor or actuator cable	I/O connectors
C	Power drop cable	24 Vdc power IN connector
D	Power drop cable	24 Vdc power OUT connector

### ⚠ WARNING

#### IP67 NON-CONFORMANCE

- Properly fit all connectors with cables or sealing plugs and tighten for IP67 conformance according to the torque values as specified in this document.
- Do not connect or disconnect cables or sealing plugs in the presence of water or moisture.

**Failure to follow these instructions can result in death, serious injury, or equipment damage.**

### NOTICE

#### ELECTROSTATIC DISCHARGE

- Never touch the pin connectors of the block.
- Always keep the cables or sealing plugs in place during normal operation.

**Failure to follow these instructions can result in equipment damage.**

## TM7 Cables References

For more information on the type and length of cables, along with their references, refer to TM7 Cables (see PacDrive TM5 / TM7 Flexible System, System Planning and Installation Guide).

## TM7 I/O Blocks Pin and Connector Assignments of Communication and Power Connectors)

The following figure presents the connector assignments of a TM7 I/O block for the communication and power connectors (A, B, C and D):

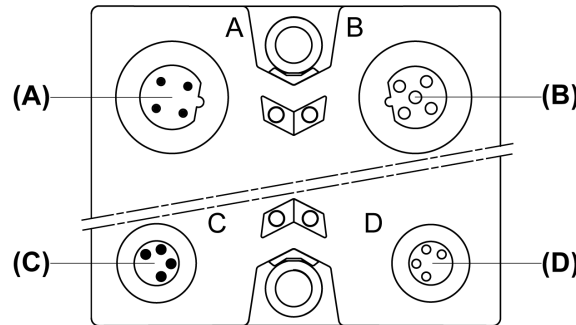

- (A) TM7 bus IN connector M12
- (B) TM7 bus OUT connector M12
- (C) 24 Vdc power IN connector M8
- (D) 24 Vdc power OUT connector M8

The following figure presents the pin assignments of the TM7 bus IN (A) and OUT (B) connectors:

Connection	Pin	Designation
	1	TM7 V+
	2	TM7 Bus Data
	3	TM7 0 Vdc
	4	TM7 Bus $\overline{\text{Data}}$
	5	N.C.

The following figure presents the pin assignments of the 24 Vdc power IN (C) and OUT (D) connectors:

Connection	Pin	Designation
	1	24 Vdc I/O power segment
	2	24 Vdc I/O power segment
	3	0 Vdc
	4	0 Vdc

**NOTE:**

- The status of the LED indicators are provided in the *Presentation* section of the I/O block.
- The pin assignments of the I/O connectors are provided in the *Wiring* section of each I/O block.

**Dimensions**

The following figures presents the dimensions of the TM7 blocks:

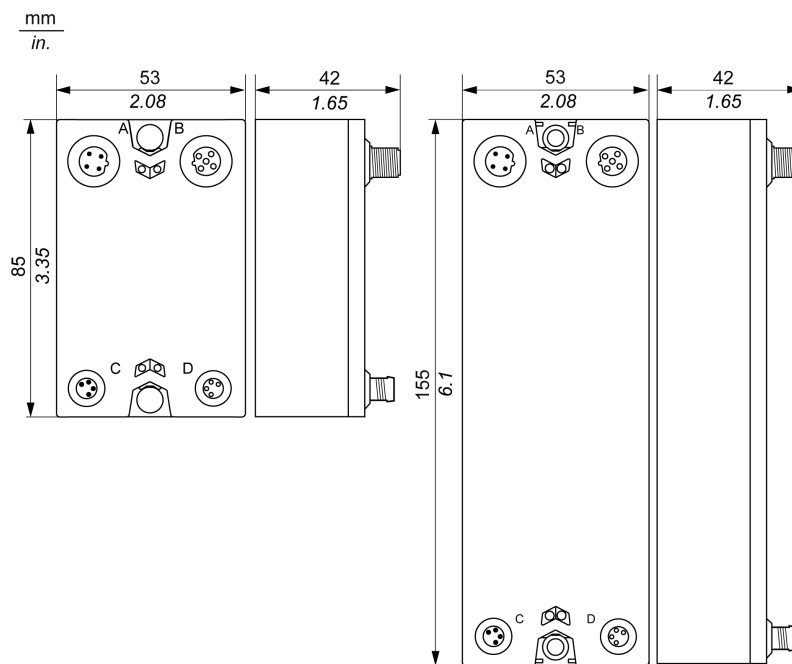

TM7SDI8DFS

TM7SDM12DTFS

# Examining the Entire TM5/TM7 System According to ISO 13849

## What's in This Chapter

Examining the Entire TM5/TM7 System, According to ISO 13849 ..... 38

## Examining the Entire TM5/TM7 System, According to ISO 13849

### Components

For calculating the total performance level (PL) in a safety-related application according to table 11 of ISO 13849, safety-related devices can be accepted as a single Safety Related Part of the Control System (SRP/SC: ISO 13849: Part of a controller that reacts to safety-related input signals and generates safety-related output signals).

Valid configuration for consideration as one entire system is 100 safety-related devices.

The TM5CSLC100FS controller can support up to 20 safety-related devices (for example, TM5/TM7 Safety I/O modules, TM5 Safety Power Distribution module, drives with embedded safety, etc.). The TM5CSLC200FS can support up to 100 safety-related devices.

### Characteristics

The following safety-related characteristics are valid for a single SRP/CS group.

Safety-related characteristics in the TM5/TM7 System:

Criteria	Characteristic value
Maximum performance level according to EN ISO 13849	PL e
Diagnostic Coverage (DC)	>90%

**NOTE:** Safety-related functions that include an output module with the `DisableOSSD = Yes-ATTENTION` parameter can reduce the performance level of the entire system. As a result, the safety-related characteristics in the following table should be used.

Safety-related characteristics in the TM5/TM7 System with `DisableOSSD = Yes-ATTENTION`:

Criteria	Characteristic value
Maximum performance level according to EN ISO 13849	PL d
Diagnostic Coverage (DC)	>90%

**NOTE:** For safety-related application with a larger number of safety-related devices than the maximum amount considered valid as one entire system (100 safety-related devices), the simplified calculation method according to table 11 of ISO 13849 cannot be used. In this case, the standard calculation method must be used.

# Channel Characteristics

## What's in This Chapter

- Digital Input Channels..... 39
- Digital Output Channels ..... 49
- Relay Channels..... 54
- Analog Input Channels TM5SAI4AFS Safety Module 2x2AI 4-20mA 24 Bits ..... 57
- Analog Input Channels TM5STI4ATCFS Safety Module 2x2AI Thermocouple..... 61

## Digital Input Channels

### Filters

#### Overview

The Safety Digital Input modules are equipped with separately configurable switch-on and switch-off filters. The functionality of the filter depends on the firmware version and is presented in the following table and figures:

Module type	Version	Schema TOFF filter	Additional filter time to be considered for the total reaction time
I/O-Module	<301	Schema 1	2x TOFF filter time
I/O-Module	≥301	Schema 2	1x TOFF filter time

Schema 1

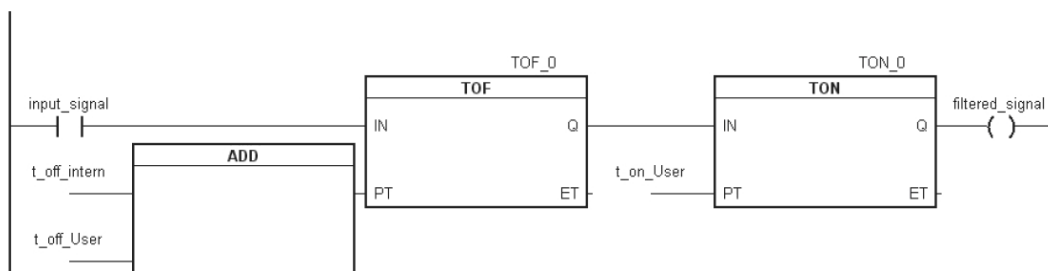

Schema 2

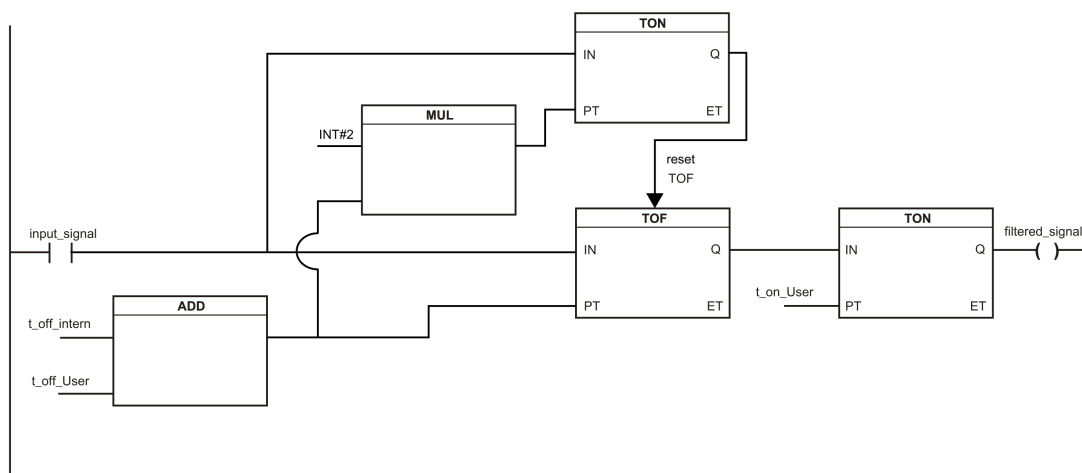

- Input signal: Status of the input channel
- Filtered signal: Filtered status of the input channel - used as an input for the PLCopen function block and forwarded to the Safety Logic Controller.

- `t_off_intern`: Internal parameter for suppressing the external test pulses (only in external test pulse mode: 5 ms)
- `t_off_user`: Parameters for the switch-off filter
- `t_on_user`: Parameters for the switch-on filter

## Unfiltered

The input status is registered with a fixed offset with respect to the network cycle and transferred.

## Switch-on Filter

The filtered status is registered for the transition from 0 to 1 with a fixed offset with respect to the network cycle and transferred. The filter value parameter can be set, and the limit values are listed in the technical data of the EcoStruxure Machine Expert - Safety software.

Errors caused by short circuits to other signals are detected by the module within the *error detection time*, page 73 at the latest. By default, the switch-on filter is set to the error detection time value, which filters spurious signals that can be caused by a short circuit. If the switch-on filter is set to a value less than the error detection time, brief switch-on pulses can occur in combination with possible spurious signals, causing false-positive requests of the safety system.

**NOTE:** The functioning filter is dependent on the internal cycle time of the module, which is dependent on the TM5 bus cycle time. The actual functioning filter can therefore deviate below the input value by the maximum internal cycle time (refer to the *General Characteristics* of the module).

## Switch-Off Filter

The filtered status is registered for the transition from 1 to 0 with a fixed offset with respect to the network cycle and transferred. The switch-off filter can be configured separately. This makes it possible to use the switch-off filter in applications (for example testing gaps of the light curtain) and to shorten reaction times. The filter value parameter can be set, and the limit values are listed in the technical data of the EcoStruxure Machine Expert - Safety software.

If a switch-off filter is used, then the total response time of the safety system is extended. This means that the configured filter value must be added to the total response time.

### **▲ WARNING**

#### **INACCURATE RISK ASSESSMENT**

Be sure to include in your risk assessment the configured filter value added to the total response time of your system.

**Failure to follow these instructions can result in death, serious injury, or equipment damage.**

**NOTE:** The functioning filter is dependent on the internal cycle time of the module, which is dependent on the TM5 bus cycle time. The actual functioning filter can therefore deviate below the input value by the maximum internal cycle time, page 71.

## Error Detection

### Detected Internal Module Errors

The red **S** and **E** LED indicators make it possible to evaluate the following error states:



- Detected internal module error (hardware error)
- Over/under temperature
- Over/under voltage
- Incompatible firmware version

The wiring issues described in the section *Connections examples*, page 42 are detected using the red I/O channel LED indicator.

**NOTE:** Errors that occur within the module are detected according to the requirements of the relevant standards and within the minimum safety-related response time specified in the technical data of the EcoStruxure Machine Expert - Safety software.

After an error within the module is detected, the module reverts back to a defined safe state.

**NOTE:** The error detection time specified in the technical data is relevant only for detecting external errors (for example wiring errors) in single-channel structures.

### External Wiring Errors

Recognizable errors are detected by the module within the error detection time.

If a module detects an error, then:

- The channel LED indicator is lit constantly red
- The `SafeChannelOKxx` signal is set to `SAFEFALSE`.
- The `SafeDigitalInputxx` or `SafeDigitalOutputxx` signal is set to `SAFEFALSE`.
- An entry is generated in the Safelogger of EcoStruxure Machine Expert.

Other errors that are not detected by the module (or not detected on time) may lead to unintended machine states and therefore must be uncovered using additional measures.

<b>▲ WARNING</b>
<b>UNINTENDED EQUIPMENT OPERATION</b>
Be sure that your risk assessment takes into account errors which are undetectable by the Safety I/O module, and that appropriate additional measures are implemented according to your risk assessment.
<b>Failure to follow these instructions can result in death, serious injury, or equipment damage.</b>

For more information on errors that are, and are not, detected by the Safety I/O module, refer to the *Error Detection* tables found in the *Connection Examples*.

Make all necessary repairs in a timely manner if an error occurs because subsequent errors could create a hazardous situation.

<b>▲ WARNING</b>
<b>UNINTENDED EQUIPMENT OPERATION</b>
<ul style="list-style-type: none"> <li>• Immediately replace any and all modules that indicate that they are in an inoperable state.</li> <li>• Ensure that the effect on un-repaired equipment is taken into account in your risk assessment.</li> <li>• Make all necessary repairs to equipment before re-starting, or continuing service of, your machine.</li> </ul>
<b>Failure to follow these instructions can result in death, serious injury, or equipment damage.</b>

## Connection Examples

### Overview

The following sections present typical connection examples, which only represent one of the possible wiring methods.

### Connecting Single-Channel Sensors with Contacts

The following graphic presents the single-channel connection of sensors with contacts:

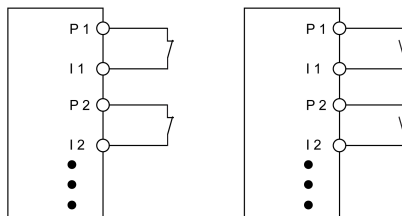

**P** Test (pulse) output

**I** Input

Single-channel sensors with contacts are a simple connection. With this connection, the module corresponds to Category 3 according to EN ISO 13849. This only applies to the module and not to the wiring presented.

#### ⚠ WARNING

##### NON-CONFORMANCE TO SAFETY FUNCTION REQUIREMENTS

Wire the sensor in accordance with the required category and features of the sensor.

**Failure to follow these instructions can result in death, serious injury, or equipment damage.**

The test output issues a specific signal that helps detect wiring issues, such as a short circuit of the +24 V, COM, or other signal channels.

**NOTE:** The status of the connected sensors with contacts is signaled via channel-specific LED indicators. The LED indicators **OO** and **OC** are not relevant in this single-channel connection.

#### ⚠ WARNING

##### UNINTENDED EQUIPMENT OPERATION

Be sure that your risk assessment takes into account errors which are undetectable by the Safety I/O module, and that appropriate additional measures are implemented according to your risk assessment.

**Failure to follow these instructions can result in death, serious injury, or equipment damage.**

This wiring provides the following error detection when `PulseMode=internal`:

Potential error	Error detection	
	Open	Closed
Ground error on test (pulse) output	Detected	Detected
Test (pulse) output short-circuit with 24 V	Detected	Detected
Short circuit between test (pulse) output and other test (pulse) signal	Detected	Detected

Potential error	Error detection	
	Open	Closed
Ground error on signal input	Not detected	Detected
Signal input short-circuit with 24 V	Detected	Detected
Short circuit between signal input and other test (pulse) signal	Detected	Detected
Short circuit between test (pulse) output and signal input	Not detected	Not detected
Broken wire	Not detected	Not detected

Make all necessary repairs in a timely manner if an error occurs because subsequent errors could create a hazardous situation.

⚠ WARNING
UNINTENDED EQUIPMENT OPERATION
<ul style="list-style-type: none"> <li>• Immediately replace any and all modules that indicate that they are in an inoperable state.</li> <li>• Ensure that the effect on un-repaired equipment is taken into account in your risk assessment.</li> <li>• Make all necessary repairs to equipment before re-starting, or continuing service of, your machine.</li> </ul> <p><b>Failure to follow these instructions can result in death, serious injury, or equipment damage.</b></p>

**NOTE:** With the configuration `PulseMode=internal`, the test pulses have a low phase of about 300 μs. This low phase is designed such that no additional decline in total response time can occur in the system. However, issues can arise with the factory setting clock form when line lengths are used that exceed the maximum cable length (refer to *General Characteristics*, page 71). In such cases, the external clock form can also be used for normal, electro-mechanic contacts. Keep in mind, however, that the effectiveness of error detection is reduced, and the total response time is increased.

### Connecting Two-Channel Sensors with Contacts

The following graphic presents the two-channel sensors with contacts:

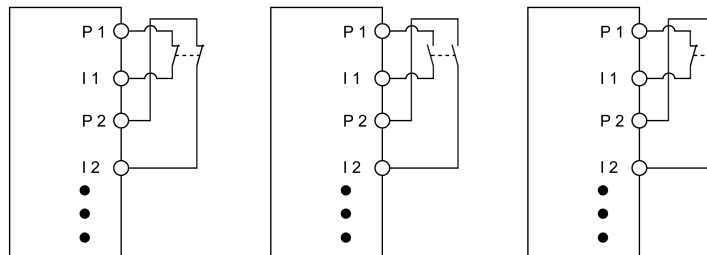

**P** Test (pulse) output

**I** Input

- Two-channel sensors with contacts can be connected directly to a safety-related digital input module.
- The two-channel evaluation is handled directly by the module.

With this connection, the module corresponds to Category 4 according to EN ISO 13849. This only applies only to the module and not to the wiring presented.

**⚠ WARNING****NON-CONFORMANCE TO SAFETY FUNCTION REQUIREMENTS**

Wire the sensor in accordance with the required category and features of the sensor.

**Failure to follow these instructions can result in death, serious injury, or equipment damage.**

The test output issues a specific signal that helps detect wiring issues, such as a short circuit of the +24 V, COM, or other signal channels.

**NOTE:** The status of the connected sensors with contacts is signaled via channel-specific LED indicators and the status of the two-channel evaluation is signaled via the **OO** (for combinations with NC/NC contact) or **OC** LED indicators (for combinations with NC/NO contact).

On module types that do not have these LED indicators, errors detected by the two-channel monitoring are indicated by the LED indicator for the respective channel flashing red.

**⚠ WARNING****UNINTENDED EQUIPMENT OPERATION**

Be sure that your risk assessment takes into account errors which are undetectable by the Safety I/O module, and that appropriate additional measures are implemented according to your risk assessment.

**Failure to follow these instructions can result in death, serious injury, or equipment damage.**

This wiring provides the following error detection when `PulseMode=internal` in combination with two-channel evaluation in the module or in the Machine Expert - Safety software:

Potential error	Error detection	
	Open	Closed
Ground error on test (pulse) output	Detected	Detected
Test (pulse) output short-circuit with 24 V	Detected	Detected
Short circuit between test (pulse) output and other test (pulse) signal	Detected	Detected
Ground error on signal input	Not detected	Detected
Signal input short-circuit with 24 V	Detected	Detected
Short circuit between signal input and other test (pulse) signal	Detected	Detected
Short circuit between test (pulse) output and signal input	Detected <sup>1)</sup>	Not detected
Broken wire	Not detected	Detected <sup>1)</sup>

<sup>1)</sup> Two-channel evaluation of the module

Make all necessary repairs in a timely manner if an error occurs because subsequent errors could create a hazardous situation.

## ▲ WARNING

### UNINTENDED EQUIPMENT OPERATION

- Immediately replace any and all modules that indicate that they are in an inoperable state.
- Ensure that the effect on un-repaired equipment is taken into account in your risk assessment.
- Make all necessary repairs to equipment before re-starting, or continuing service of, your machine.

**Failure to follow these instructions can result in death, serious injury, or equipment damage.**

**NOTE:** With the configuration `PulseMode=internal`, the test pulses have a low phase of about 300  $\mu$ s. This low phase is designed such that no additional decline in total response time can occur in the system. However, issues can arise with the factory setting clock form when line lengths are used that exceed the maximum cable length (refer to *General Characteristics*, page 71). In such cases, the external clock form can also be used for normal, electro-mechanic contacts. Keep in mind, however, that the effectiveness of error detection is reduced, and the total response time is increased.

### Connecting Multi-Channel Sensors with Contacts

The following graphic presents the connection of multi-channel, electro-mechanical switches:

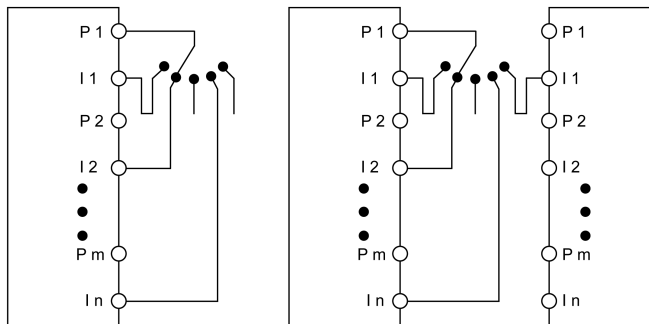

**P** Test (pulse) output

**I** Input

Multi-channel switches (operating mode switches, switching devices with shifting capability) may be connected to several safety-related, digital input devices. All inputs must be configured to use the same test (pulse) rate coming from the same test (pulse) source. The modules that are not using an internal test source must be configured to use an external test source (`PulseMode=external`). That is to say, a test source external to itself, but from another TM5/TM7 module as you can see in the left-most wiring diagram.

The modules that use an internal test (pulse) source must be configured to use an internal test source (`PulseMode=internal`).

The difference between using a single module and multiple modules is the system response time. In the case of multiple modules, test (pulse) rate must be set to a wave form of 4 ms low phase. In the case of a single module, you can set a wave form of 300  $\mu$ s low phase.

<b>⚠ WARNING</b>
<b>UNINTENDED EQUIPMENT OPERATION</b>
Add 5 ms to the total response time when configuring <code>PulseMode=external</code> .
<b>Failure to follow these instructions can result in death, serious injury, or equipment damage.</b>

When connecting multi-channel sensors with contacts, the multi-channel analysis must be executed in the safety-related application (PLCopen function block `ModeSelector`).

**NOTE:** Achieving the desired category according to EN ISO 13849 depends on the error models of the switching element (for example mode selector switch) and must be examined in combination with the error detection present in the PLCopen function block.

The status of the connected sensors is indicated by channel-specific LED indicators. The LED indicators **OO** and **OC** are not relevant when using multi-channel selectors.

<b>⚠ WARNING</b>
<b>UNINTENDED EQUIPMENT OPERATION</b>
Be sure that your risk assessment takes into account errors which are undetectable by the Safety I/O module, and that appropriate additional measures are implemented according to your risk assessment.
<b>Failure to follow these instructions can result in death, serious injury, or equipment damage.</b>

This wiring provides the following error detection when `PulseMode=external`:

Potential error	Error detection
Ground error on test (pulse) output	Detected
Test (pulse) output short-circuit with 24 V	Detected
Short circuit between test (pulse) output and other test (pulse) signal	Detected <sup>1)</sup>
Ground error on signal input (active signal)	Detected <sup>1)</sup>
Ground error on signal input (inactive signal)	Not detected
Signal input short-circuit with 24 V	Detected
Short circuit between signal input and other test (pulse) signal	Detected <sup>1)</sup>
Short circuit between test (pulse) output and signal input (active signal)	Not detected
Broken wire (active signal)	Detected <sup>1)</sup>
Short circuit between test (pulse) output and signal input (input signal)	Detected <sup>1)</sup>
Broken wire (inactive signal)	Not detected

<sup>1)</sup> Detected in the application by PLCopen function block `ModeSelector`.

This wiring provides the following error detection when `PulseMode=internal`:

Potential error	Error detection	
	Open	Closed
Ground error on test (pulse) output	Detected	Detected
Test (pulse) output short-circuit with 24 V	Detected	Detected
Short circuit between test (pulse) output and other test (pulse) signal	Detected	Detected
Ground error on signal input	Not detected	Detected

Potential error	Error detection	
	Open	Closed
Signal input short-circuit with 24 V	Detected	Detected
Short circuit between signal input and other test (pulse) signal	Detected	Detected
Short circuit between test (pulse) output and signal input	Not detected	Not detected
Broken wire	Not detected	Not detected

Make all necessary repairs in a timely manner if an error occurs because subsequent errors could create a hazardous situation.

**⚠ WARNING**

**UNINTENDED EQUIPMENT OPERATION**

- Immediately replace any and all modules that indicate that they are in an inoperable state.
- Ensure that the effect on un-repaired equipment is taken into account in your risk assessment.
- Make all necessary repairs to equipment before re-starting, or continuing service of, your machine.

**Failure to follow these instructions can result in death, serious injury, or equipment damage.**

**NOTE:** With the configuration `PulseMode=internal`, the test pulses have a low phase of about 300 μs. This low phase is designed such that no additional decline in total response time can occur in the system. However, issues can arise with the factory setting clock form when line lengths are used that exceed the maximum cable length (refer to [General Characteristics](#), page 71). In such cases, the external clock form can also be used for normal, electro-mechanic contacts. Keep in mind, however, that the effectiveness of error detection is reduced, and the total response time is increased.

### Connecting Electronic Sensors

The following graphic presents the connection of electronic sensors (EPE, inductive sensors, and so on):

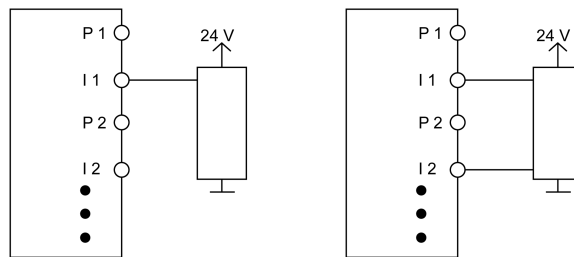

**P** Test (pulse) output

**I** Input

Electronic sensors (light curtain, laser scanners, inductive sensors) may also be connected to safety-related digital input modules.

Some electronic sensors feature OSSD (Output Signal Switching Device) outputs. These types of outputs include a pulse train similar to the test outputs of the Safety I/O module. However, these pulses are not exploitable by the module. For this reason, the input channels must be configured to `PulseMode=none`.

Further, gaps in the test of the connected OSSD outputs must be masked out with the switch-off filter of the module to help avoid false-positive safety-related requests. The configuration of a switch-off filter lengthens the safety-related response time.

**⚠ WARNING****UNINTENDED EQUIPMENT OPERATION**

Ensure that the configured filter value is added to the total response time.

**Failure to follow these instructions can result in death, serious injury, or equipment damage.**

When `PulseMode=none`, the module cannot detect wiring issues.

**⚠ WARNING****UNINTENDED EQUIPMENT OPERATION**

- Include in your risk assessment the possibility of inoperable electronic sensors, short-circuits and other wiring issues.
- If necessary, employ supplementary measures to mitigate issues that may arise using electronic sensors.

**Failure to follow these instructions can result in death, serious injury, or equipment damage.**

With single-channel wiring, the module corresponds to Category 3 according to EN ISO 13849. With two-channel wiring, the module corresponds to Category 4 according to EN ISO 13849. This only applies to the module and not to the wiring presented.

**⚠ WARNING****NON-CONFORMANCE TO SAFETY FUNCTION REQUIREMENTS**

Wire the sensor in accordance with the required category and features of the sensor.

**Failure to follow these instructions can result in death, serious injury, or equipment damage.**

Make all necessary repairs in a timely manner if an error occurs because subsequent errors could create a hazardous situation.

**⚠ WARNING****UNINTENDED EQUIPMENT OPERATION**

- Immediately replace any and all modules that indicate that they are in an inoperable state.
- Ensure that the effect on un-repaired equipment is taken into account in your risk assessment.
- Make all necessary repairs to equipment before re-starting, or continuing service of, your machine.

**Failure to follow these instructions can result in death, serious injury, or equipment damage.**

**Using the Same Test Outputs**

When using the same test outputs for different inputs, the inputs must be isolated from one another. Otherwise, damage to the cables may cause errors that are not detected by the module.



The following graphic presents the connection with the same test (pulse) signals:

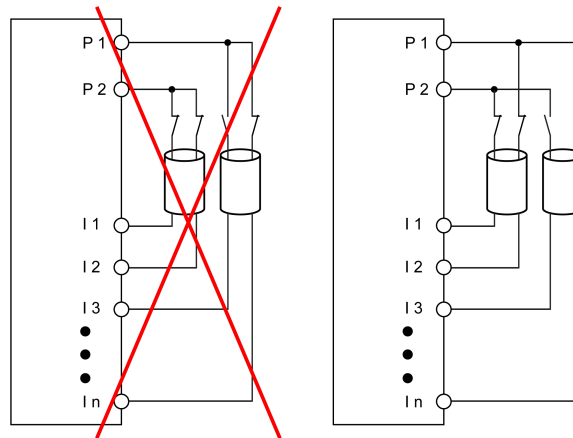

**P** Test (pulse) output

**I** Input

## ⚠ WARNING

### UNINTENDED EQUIPMENT OPERATION

Wire same test signal in different cables, or implement other error-prevention measures in accordance with EN ISO 13849-2.

**Failure to follow these instructions can result in death, serious injury, or equipment damage.**

## Digital Output Channels

### Error Detection

#### Detected Internal Module Errors

The red **S** and **E** LED indicators make it possible to evaluate the following error states:

- Detected internal module error (hardware error)
- Over/under temperature
- Over/under voltage
- Incompatible firmware version

The wiring issues described in the section [Connection Examples](#), page 50 are detected using the red I/O channel LED indicator.

**NOTE:** Errors that occur within the module are detected according to the requirements of the relevant standards and within the minimum safety-related response time specified in the technical data of the EcoStruxure Machine Expert - Safety software.

After an error within the module is detected, the module reverts back to a defined safe state.

**NOTE:** The error detection time specified in the technical data is relevant only for detecting external errors (for example wiring errors) in single-channel structures.

#### External Wiring Errors

Recognizable errors are detected by the module within the error detection time.

If a module detects an error, then:

- The channel LED indicator is lit constantly red
- The `SafeChannelOKxx` signal is set to `SAFEFALSE`.
- The `SafeDigitalInputxx` or `SafeDigitalOutputxx` signal is set to `SAFEFALSE`.
- An entry is generated in the Safelogger of EcoStruxure Machine Expert.

For more information on wiring errors, refer to [Connection Examples](#), page 50.

Other errors that are not detected by the module (or not detected on time) may lead to unintended machine states and therefore must be uncovered using additional measures.

## ⚠ WARNING

### UNINTENDED EQUIPMENT OPERATION

Be sure that your risk assessment takes into account errors which are undetectable by the Safety I/O module, and that appropriate additional measures are implemented according to your risk assessment.

**Failure to follow these instructions can result in death, serious injury, or equipment damage.**

For more information on errors that are, and are not, detected by the Safety I/O module, refer to the *Error Detection* tables found in the *Connection Examples*.

Make all necessary repairs in a timely manner if an error occurs because subsequent errors could create a hazardous situation.

## ⚠ WARNING

### UNINTENDED EQUIPMENT OPERATION

- Immediately replace any and all modules that indicate that they are in an inoperable state.
- Ensure that the effect on un-repaired equipment is taken into account in your risk assessment.
- Make all necessary repairs to equipment before re-starting, or continuing service of, your machine.

**Failure to follow these instructions can result in death, serious injury, or equipment damage.**

## Connection Examples

### Overview

The following sections list typical connection examples, which only represent some of the possible wiring methods. You must consider the error detection listed in the respective examples.

## ⚠ WARNING

### UNINTENDED EQUIPMENT OPERATION

Be sure that your risk assessment takes into account errors which are undetectable by the Safety I/O module, and that appropriate additional measures are implemented according to your risk assessment.

**Failure to follow these instructions can result in death, serious injury, or equipment damage.**

For more information regarding error detection, refer to the sections described in *Error Detection*, page 49.

**NOTE:** For information on the Enabling Principle and Restart Behavior, refer to the I/O configuration in EcoStruxure Machine Expert / EcoStruxure Machine Expert - Safety.

### Connecting Safety-Oriented Actuators

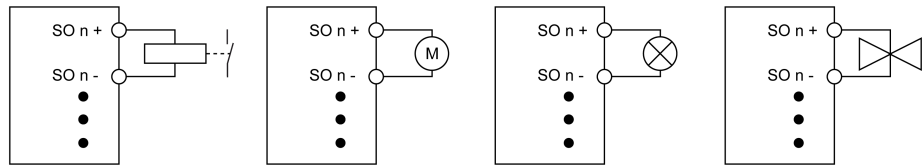

Safety-related actuators (contactors, motors, muting lamps, valves) that are compatible with output module performance data may be connected directly. With this connection, the module corresponds to Category 4 according to EN ISO 13849. This only applies to the module and not to the wiring presented.

<b>⚠ WARNING</b>
<b>NON-CONFORMANCE TO SAFETY FUNCTION REQUIREMENTS</b>
Wire the actuator in accordance with the required category and features of the actuator.
<b>Failure to follow these instructions can result in death, serious injury, or equipment damage.</b>

For the TM5SDO2TFS, TM5SDO2TAFS, TM5SDO4TFS and TM5SDO4TAFS modules, the output channels also de-energize the load on the COM side. Verify whether the actuators you have connected permit the disconnection from the COM side.

<b>⚠ WARNING</b>
<b>UNINTENDED EQUIPMENT OPERATION</b>
Verify that the I/O modules are compatible with the actuators that are connected.
<b>Failure to follow these instructions can result in death, serious injury, or equipment damage.</b>

<b>⚠ WARNING</b>
<b>UNINTENDED EQUIPMENT OPERATION</b>
Be sure that your risk assessment takes into account errors which are undetectable by the Safety I/O module, and that appropriate additional measures are implemented according to your risk assessment.
<b>Failure to follow these instructions can result in death, serious injury, or equipment damage.</b>

With this wiring, the modules detect following errors:

Error	DisableOSSD= No		DisableOSSD= Yes-ATTENTION	
	Error at output			
	De-energized	Energized	De-energized	Energized
Ground error on SO n+				
TM5SDO•FS	not detected	detected	not detected	detected
Ground error on SO n-				

Error	DisableOSSD= No		DisableOSSD= Yes-ATTENTION	
	Error at output			
	De-energized	Energized	De-energized	Energized
TM5SDO•TFS, TM5SDO•TAFS	not detected	detected	not detected	not detected
SO n+ short-circuit with 24 Vdc				
TM5SDO•TFS, TM5SDO•TAFS	detected	detected	detected	not detected
TM5SDO6TBFS	detected <sup>1)</sup>	not detected	detected <sup>1)</sup>	
TM5SDM8TBFS		detected <sup>1)</sup>		
TM7SDM12DTFS				
SO n- short-circuit with 24 Vdc				
TM5SDO•TFS, TM5SDO•TAFS	detected	detected	detected	detected
COM short-circuit with 24 Vdc				
TM5SDO6TBFS	not detected	not detected	not detected	not detected
TM5SDM8TBFS				
TM7SDM12DTFS				
Short circuit between SO n+ and the other signal (high)				
TM5SDO•TFS, TM5SDO•TAFS	detected	detected	detected	not detected
TM5SDO6TBFS	detected <sup>1)</sup>	not detected	detected <sup>1)</sup>	
TM5SDM8TBFS		detected <sup>1)</sup>		
TM7SDM12DTFS				
Short circuit between SO n- and the other signal (high)				
TM5SDO•TFS, TM5SDO•TAFS	detected	detected	detected	not detected
Short circuit between COM and the other signal (high)				
TM5SDO6TBFS	not detected	not detected	not detected	not detected
TM5SDM8TBFS				
TM7SDM12DTFS				
Broken wire				
TM5SDO•TFS, TM5SDO•TAFS	not detected	not detected <sup>2)</sup>	not detected	not detected <sup>2)</sup>
TM5SDO6TBFS		not detected		not detected
TM5SDM8TBFS				
TM7SDM12DTFS				
Short circuit between SO n+ and SO n-				
TM5SDO•TFS, TM5SDO•TAFS	not detected	detected	not detected	detected
<sup>1)</sup> Short-circuits on SO n caused by high potentials will be detected by the modules, however the connected actuator cannot be de-energized due to the positive power switching design of the channel. <sup>2)</sup> Broken wire can be acknowledged via the CurrentOk signal. However, this signal cannot be used for safety purposes.				

With this wiring, the TM5SPS10FS, TM5SDO6TBFS, TM5SDM8TBFS and TM7SDM12DTFS modules have the following error detection:

Error	Error at Output	
	De-energized	Energized
Ground error on SO x	not detected	detected
SO x short-circuit with 24 Vdc	detected <sup>1)</sup>	detected <sup>1)</sup> <b>NOTE:</b> This error is not detected for TM5SDO6TBFS.
COM short-circuit with 24 Vdc	<b>NOTE:</b> This potential error is not detected.	<b>NOTE:</b> This potential error is not detected.

Error	Error at Output	
	De-energized	Energized
Short circuit between $SO_x$ and the other signal (high)	detected <sup>1)</sup>	detected <sup>1)</sup> <b>NOTE:</b> This error is not detected for TM5SDO6TBFS.
Short circuit between COM and the other signal (high)	<b>NOTE:</b> This potential error is not detected.	<b>NOTE:</b> This potential error is not detected.
Broken wire	<b>NOTE:</b> This potential error is not detected.	<b>NOTE:</b> This potential error is not detected <sup>1)</sup> .

<sup>1)</sup> Short-circuits on  $SO_x$  caused by high potentials will be detected by the modules, however the connected actuator cannot be de-energized due to the positive power switching design of the channel.

**NOTE:** With `DisableOSSD` set to Yes-ATTENTION, the modules have reduced error detection capabilities and no longer meets the requirements of SIL 3 according to IEC 62061, nor PL e according to ISO 13849. If you have set the parameter as such, you need to review the cited standards for more information in regards to your responsibilities.

Invalid connection of an actuator:

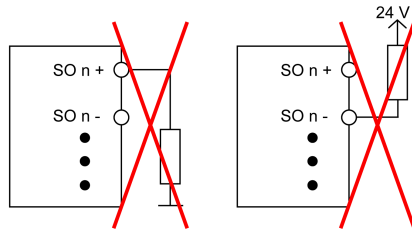

Directly connecting an actuator from +24 Vdc to  $SO_{n-}$ , or connecting  $SO_{n+}$  to an actuator, and then to the external ground is invalid. These types of wiring errors will not be detected by the modules.

<b>⚠ WARNING</b>
<b>INOPERATIVE SAFETY-RELATED FUNCTIONALITY</b>
<ul style="list-style-type: none"> <li>Do not directly connect an actuator from +24 Vdc to <math>SO_{n-}</math>.</li> <li>Do not directly connect an actuator from <math>SO_{n-}</math> to an external ground connection.</li> </ul>
<b>Failure to follow these instructions can result in death, serious injury, or equipment damage.</b>

Make all necessary repairs in a timely manner if an error occurs because subsequent errors could create a hazardous situation.

<b>⚠ WARNING</b>
<b>UNINTENDED EQUIPMENT OPERATION</b>
<ul style="list-style-type: none"> <li>Immediately replace any and all modules that indicate that they are in an inoperable state.</li> <li>Ensure that the effect on un-repaired equipment is taken into account in your risk assessment.</li> <li>Make all necessary repairs to equipment before re-starting, or continuing service of, your machine.</li> </ul>
<b>Failure to follow these instructions can result in death, serious injury, or equipment damage.</b>

## Relay Channels

### Error Detection

#### Detected Internal Module Errors

The red **S** and **E** LED indicators make it possible to evaluate the following error states:

- Detected internal module error (hardware error)
- Inoperable relay
- Over/under temperature
- Over/under voltage
- Incompatible firmware version

The wiring issues described in the section Connection Examples are detected using the red I/O channel LED indicator.

#### External Wiring Errors

If a module detects an error, then:

- The channel LED indicator is lit constantly red
- The `SafeChannelOKxx` signal is set to `SAFEFALSE`.
- The `SafeDigitalInputxx` or `SafeDigitalOutputxx` signal is set to `SAFEFALSE`.
- An entry is generated in the Safelogger of EcoStruxure Machine Expert.

Other errors that are not detected by the module (or not detected on time) may lead to unintended machine states and therefore must be uncovered using additional measures.

### ⚠ WARNING

#### UNINTENDED EQUIPMENT OPERATION

Be sure that your risk assessment takes into account errors which are undetectable by the Safety I/O module, and that appropriate additional measures are implemented according to your risk assessment.

**Failure to follow these instructions can result in death, serious injury, or equipment damage.**

For more information on errors that are, and are not, detected by the Safety I/O module, refer to the *Error Detection* tables found in the *Connection Examples*.

Make all necessary repairs in a timely manner if an error occurs because subsequent errors could create a hazardous situation.

### ⚠ WARNING

#### UNINTENDED EQUIPMENT OPERATION

- Immediately replace any and all modules that indicate that they are in an inoperable state.
- Ensure that the effect on un-repaired equipment is taken into account in your risk assessment.
- Make all necessary repairs to equipment before re-starting, or continuing service of, your machine.

**Failure to follow these instructions can result in death, serious injury, or equipment damage.**

## Connection Examples

### Overview

The connection examples listed here only represent some of the possible wiring methods. However, the following must be taken into consideration regardless:

- Two relay channels must be connected in series when used for a higher safety level (greater than or equal to category 2 or PL b according to ISO 13849 or SIL 1 according to IEC 62061).
- The relay contacts must be protected with a fuse (Relay Output Characteristics, page 157).

**⚠ DANGER**

**FIRE HAZARD**

- Use only the correct wire sizes for the current capacity of the I/O channels and power supplies.
- For relay output (2 A) wiring, use conductors of at least 0.5 mm<sup>2</sup> (AWG 20) with a temperature rating of at least 80 °C (176 °F).
- For common conductors of relay output wiring (6 A), or relay output wiring greater than 2 A, use conductors of at least 1.0 mm<sup>2</sup> (AWG 16) with a temperature rating of at least 80 °C (176 °F).

**Failure to follow these instructions will result in death or serious injury.**

**NOTE:** For information on the Enabling Principle and Restart Behavior, refer to the I/O configuration in EcoStruxure Machine Expert / EcoStruxure Machine Expert - Safety.

### Connecting Safety-Oriented Actuators for Relay Outputs in Series

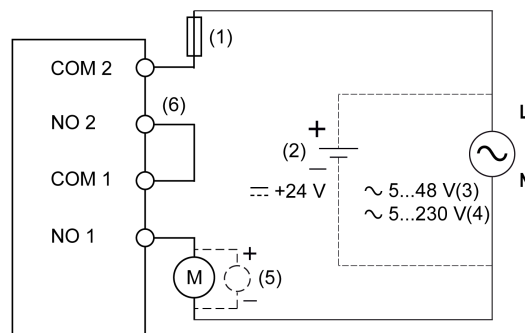

- 1 Fuse
- 2 External power supply 24 Vdc
- 3 External power supply 5...48 Vac (TM5SDM4DTRFS)
- 4 External power supply 5...230 Vac (TM5SDO2DTRFS)
- 5 Inductive load protection
- 6 External bridge NO 2 - COM 1

Inductive damage to relay types of outputs can result in welded contacts and loss of control. Each inductive load must be with a protection device such as a peak limiter, RC circuit or flyback diode. Capacitive loads are not supported by these relays.

**⚠ WARNING****RELAY OUTPUTS WELDED CLOSED**

- Always protect relay outputs from inductive alternating current load damage using an appropriate external protective circuit or device.
- Do not connect relay outputs to capacitive loads.

**Failure to follow these instructions can result in death, serious injury, or equipment damage.**

For applications that correspond to SIL 3 or 4, the two normally closed contacts for the two relays must be wired in series. In this case, control of the two relays must be handled using signal `SafeDigitalOutput0102`.

Controlling the two relay contacts using the single signal

`SafeDigitalOutput01` and `SafeDigitalOutput02` is invalid for applications corresponding to SIL 3 or 4 because certain operating states can cause the two normally closed contacts to weld together. Therefore, simultaneously using the signals `SafeDigitalOutput0102` and `SafeDigitalOutput01` or `SafeDigitalOutput02` is restricted as such by the EcoStruxure Machine Expert - Safety software.

Using the signal `SafeDigitalOutput0102` causes a switch-on sequence to be activated that switches on relay 2 with a 20 ms delay. This behavior is necessary to prevent welding of the two normally closed contacts in certain operating states.

**⚠ WARNING****UNINTENDED EQUIPMENT OPERATION**

Do not use the signals `SafeDigitalOutput0102` and `SafeDigitalOutput01` or `SafeDigitalOutput02` simultaneously.

**Failure to follow these instructions can result in death, serious injury, or equipment damage.**

**NOTE:** SIL 4 is only obtainable with the use of additional equipment.

A relay channel does not have error detection with regard to wiring issues. All errors resulting from damaged or incorrect wiring (including inappropriate loads) must be detected through supplementary measures or a connected device.

To help prevent possible error caused by short-circuits to other voltage levels, wiring that protects against short-circuits is needed for connecting the actuator.

Other errors that are not detected by the module (or not detected on time) may lead to unintended machine states and therefore must be uncovered using additional measures.

**⚠ WARNING****UNINTENDED EQUIPMENT OPERATION**

Be sure that your risk assessment takes into account errors which are undetectable by the Safety I/O module, and that appropriate additional measures are implemented according to your risk assessment.

**Failure to follow these instructions can result in death, serious injury, or equipment damage.**

Make all necessary repairs in a timely manner if an error occurs because subsequent errors could create a hazardous situation.



## ▲ WARNING

### UNINTENDED EQUIPMENT OPERATION

- Immediately replace any and all modules that indicate that they are in an inoperable state.
- Ensure that the effect on un-repaired equipment is taken into account in your risk assessment.
- Make all necessary repairs to equipment before re-starting, or continuing service of, your machine.

**Failure to follow these instructions can result in death, serious injury, or equipment damage.**

## Analog Input Channels TM5SAI4AFS Safety Module 2x2AI 4-20mA 24 Bits

### Error Detection - TM5SAI4AFS Safety Module 2x2AI 4-20mA 24 Bits

#### Detected Internal Module Errors

The red **S** and **E** LED indicators make it possible to evaluate the following error states:

- Detected internal module error (hardware error)
- Over/under temperature
- Over/under voltage
- Incompatible firmware version

**NOTE:** Errors that occur within the module are detected according to the requirements of the relevant standards and within the minimum safety-related response time specified in the technical data of the EcoStruxure Machine Expert - Safety software.

After an error within the module is detected, the module reverts to a defined safe state.

The internal module tests needed for this are only performed, however, if the firmware of the module was booted and the module is in either the preoperational state or the operational state. If this state is not achieved (for example, because the module is not configured in the application), then the module remains in boot state.

Boot mode on a module is clearly indicated by a slow flashing SE LED (2 Hz or 1 Hz).

**NOTE:** The error detection time specified in the technical data is relevant only for detecting external errors (for example wiring errors) in single-channel structures.

#### External Wiring Errors

Recognizable errors are detected by the module within the error detection time.

If a module detects an error, then:

- The channel LED indicator is lit constantly red
- The *SafeChannelOKxx* signal is set to *SAFEFALSE*.
- The *SafeCurrentOKxx* signal is set to *SAFEFALSE*.
- An entry is generated in the Safelogger of EcoStruxure Machine Expert.

Other errors that are not detected by the module (or not detected on time) may lead to unintended machine states and therefore must be uncovered using additional measures.

**⚠ WARNING****UNINTENDED EQUIPMENT OPERATION**

Be sure that your risk assessment takes into account errors which are undetectable by the Safety I/O module, and that appropriate additional measures are implemented according to your risk assessment.

**Failure to follow these instructions can result in death, serious injury, or equipment damage.**

For more information on errors that are, and are not, detected by the Safety I/O module, refer to the *Error Detection* tables found in the *Connection Examples*.

Make all necessary repairs in a timely manner if an error occurs because subsequent errors could create a hazardous situation.

**⚠ WARNING****UNINTENDED EQUIPMENT OPERATION**

- Immediately replace any and all modules that indicate that they are in an inoperable state.
- Ensure that the effect on un-repaired equipment is taken into account in your risk assessment.
- Make all necessary repairs to equipment before re-starting, or continuing service of, your machine.

**Failure to follow these instructions can result in death, serious injury, or equipment damage.**

**Inputs**

Error detection for safe inputs

Potential error	Detection	Comment
Non-wired inputs	Detected	General indication for one or more non-wired channels.
Short circuit between signal lines	May not be detected	You must take appropriate measures to ensure that this detected error does not lead to a defined safe state.  Signal and supply lines must be installed in accordance with EN ISO 13849-2:2010, Table D.5.
Short circuit between signal and supply line	May not be detected	
Reverse polarity of signal lines	Detected	Module switches to a defined safe state.
Disturbance voltage	Not detected	This error results in signal distortion that may be detected by two-channel evaluation in some circumstances. Shielded cables are mandatory for the signal lines.  Different installation paths must be used for the wiring of both signals of the signal pair.

**NOTE:** You must take appropriate measures to ensure that this error does not lead to a defined safe state.

**NOTE:** Signal and supply lines must be installed in accordance with EN ISO 13849-2:2010, Table D.5.

**Defined Safe State**

When opening the current measurement inputs, the module switches into the defined safe state.

Step	Action
1	Switch off the module.
2	Each open current measurement input of the module has to be wired with one jumper. <b>Result:</b> The module can be switched on again.

### Signal Errors

*HW\_LIMIT\_MIN* designates the lower limit and *HW\_LIMIT\_MAX* designates the upper limit of the measurement range specified in the chapter TM5SAI4AFS Presentation, page 183.

Signal evaluation takes place in three stages:

Stage 1: Evaluation of signals against absolute time limits

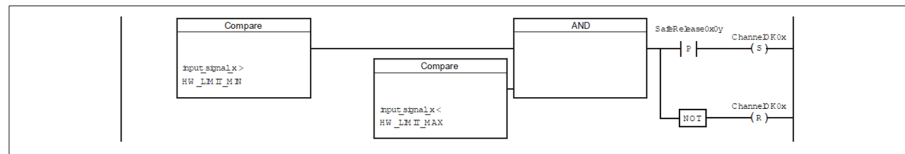

Stage 2: Evaluation of signals against configurable time limits

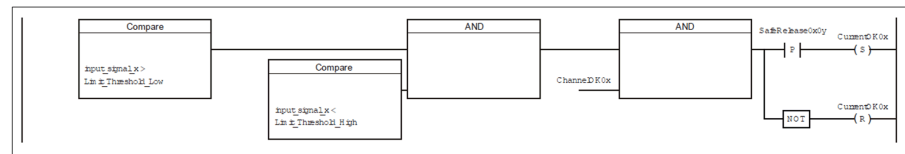

Stage 3: Evaluation of signals against configurable signal pair limits

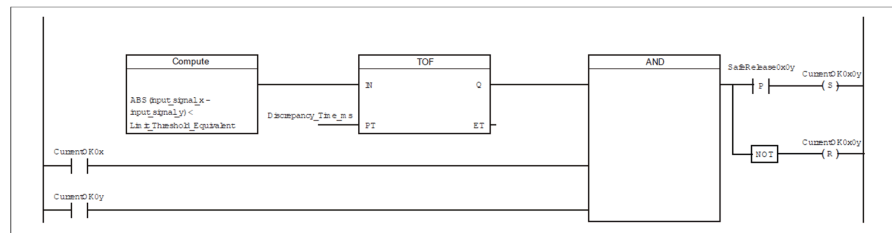

A reset must be performed in order to leave an error state. For this, a valid signal must be received at the analog input for the duration of the I/O update time. The error can then be acknowledged by a rising edge of the signal *SafeReleaseOk*.

### Channel Diagnostics

Channel electronics are automatically tested internally by the module. A test signal is generated in the module and applied to each channel once every 75 minutes for a maximum time of 1 s. To avoid signal distortion, the signal value of the channel being tested is held in a static state during this time. Only one channel is tested at a time. In accordance with EN IEC 61508:2010, the module is considered as a one out of two diagnostic system for the duration of the channel test.

In firmware version 302 of the module, the behavior for the duration of channel diagnostics is structured as follows:

The safe analog input channels (data type SAFEINT) are constituted as the arithmetic mean value of the two individual signals. Since the signal value of the channel being tested is held static for the duration of channel diagnostics, the arithmetic mean value during this period of channel diagnostics for the safe signal is taken from the static value of the diagnosed channel and the signal value of the non-diagnosed channel.

In firmware version 322 and greater, the behavior for the duration of channel diagnostics is structured as follows:

The safe analog input channels (data type SAFEINT) are constituted as the arithmetic mean value of the two individual signals. For the duration of channel diagnostics, however, it is not the arithmetic mean value that is used, but the signal value of the channel that is not currently being diagnosed. If the behavior of firmware version 302 is desired for compatibility reasons, this can be implemented using parameter *Measurement Result while Testing = Averaged*. An active channel test is indicated by channel *TestActive*.

## Channel Diagnostic Sequence

The sequence for channel diagnostic is independent of the firmware version and structured as follows:

Diagnostic window	Time sequence	Channel sequence
Diagnostic window 1	Every 75 min	SAI1
Diagnostic window 2	15 min after diagnostic window 1	SAI3
Diagnostic window 3	30 min after diagnostic window 1	SAI4
Diagnostic window 4	45 min after diagnostic window 1	SAI2

For further information about variables and parameters refer to .

In order to meet the requirements of CAT 4 per EN ISO 13849-1:2015, the shunts of the channel electrics must be tested (shunt test) despite the multi-channel structure. For a proper shunt test, the slew rate of the input signals must be limited to 200  $\mu\text{A}/\text{ms}$ .

For steeper signal edges and parameter configuration *Disable Shunttest = Yes-ATTENTION*, the module switches to defined safe state if necessary, which affects the entire module.

**NOTE:** Noisy signal sources or signals with high frequencies may result in excessively steep signal edges and can trigger a shunt test error.

**NOTE:** If issues with the slew rate of input signals or shunt test occur, the shunt test can be disabled with the parameter *Disable Shunttest = Yes-ATTENTION*. In this case the module meets only the requirements of CAT 3 per EN ISO 13849-1:2015.

## Module Functions - TM5SAI4AFS Safety Module 2x2AI 4-20mA 24 Bits

### Overview

The current taken via the input terminals is converted to measurement voltages via shunts 1 and 2, smoothed by the hardware filter (first-order low-pass / cutoff frequency 500 Hz) and digitalized in the subsequent A/D converters.

The filter values configured in the software (refer to ) are applied during digitalization in the A/D converter. The signals then pass through the three stages of digital signal processing. The safe analog input channels (data type SAFEINT) are constituted as the arithmetic mean value of the two individual signals. Also refer to *channel diagnostics*, page 64.

The validity of analog signals is represented by the associated status signals. These binary status signals (data type SAFEBOOL) must also be evaluated each time the analog signals are used. A binary status signal with the status FALSE indicates an invalid value in the analog signal. When this occurs, the analog signal is no longer permitted to be used for safety-related assessments.

A reset must be performed in order to leave an error state. For this, a valid signal must be received at the analog input for the duration of the I/O update time. The error can then be acknowledged by a rising edge of the signal *SafeRelease0x0y*.

An optional sensor power supply is available to provide power to the sensors. If the sensor is powered externally, then the 2-wire connection examples must be applied. Current measurement protects the internal module sensor power supply against overload.

## Input Circuit Diagram - TM5SAI4AFS Safety Module 2x2AI 4-20mA 24 Bits

### Overview

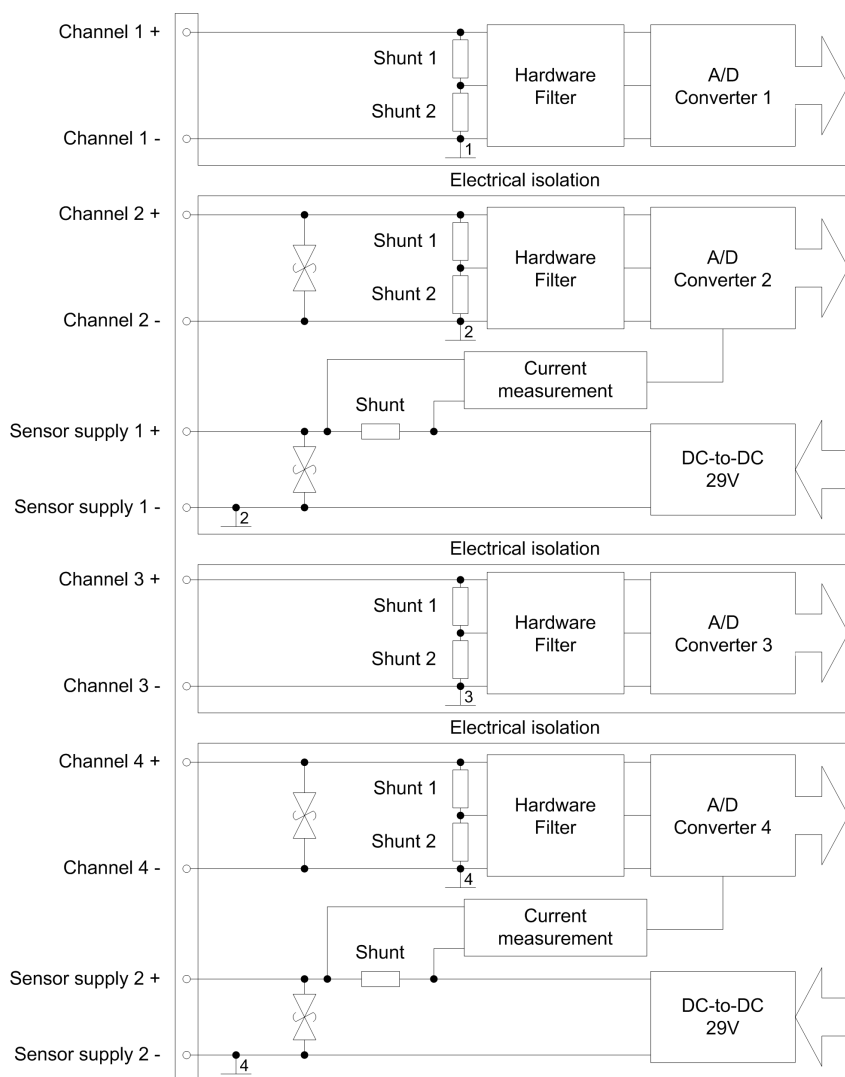

## Analog Input Channels TM5STI4ATCFS Safety Module 2x2AI Thermocouple

### Error Detection - TM5STI4ATCFS Safety Module 2x2AI Thermocouple

#### Detected Internal Module Errors

The red **S** and **E** LED indicators make it possible to evaluate the following error states

- Detected internal module error (hardware error)
- Overtemperature/Undertemperature
- Overvoltage/Undervoltage
- Incompatible firmware version

**NOTE:** Errors that occur within the module are detected according to the requirements of the relevant standards and within the minimum safety-related response time specified in the technical data of the EcoStruxure Machine Expert - Safety software.

After an error within the module is detected, the module reverts to a defined safe state.

The internal module tests needed for this are only performed, however, if the firmware of the module was booted and the module is in either the preoperational state or the operational state. If this state is not achieved (for example, because the module is not configured in the application), then the module remains in boot state.

Boot mode on a module is clearly indicated by a slow flashing SE LED (2 Hz or 1 Hz).

**NOTE:** The error detection time specified in the technical data is relevant only for detecting external errors (for example wiring errors) in single-channel structures.

## External Wiring Errors

Recognizable errors are detected by the module within the error detection time.

If a module detects an error, then:

- The channel LED indicator is lit constantly red
- The `SafeChannelOKxx` signal is set to `SAFEFALSE`.
- The `SafeTemperatureOKxx` signal is set to `SAFEFALSE`.
- An entry is generated in the Safelogger of EcoStruxure Machine Expert.

Other errors that are not detected by the module (or not detected on time) may lead to unintended machine states and therefore must be uncovered using additional measures.

### **⚠ WARNING**

#### **UNINTENDED EQUIPMENT OPERATION**

Be sure that your risk assessment takes into account errors which are undetectable by the Safety I/O module, and that appropriate additional measures are implemented according to your risk assessment.

**Failure to follow these instructions can result in death, serious injury, or equipment damage.**

For more information on errors that are, and are not, detected by the Safety I/O module, refer to the *Error Detection* tables found in the *Connection Examples*.

Make all necessary repairs in a timely manner if an error occurs because subsequent errors could create a hazardous situation.

### **⚠ WARNING**

#### **UNINTENDED EQUIPMENT OPERATION**

- Immediately replace any and all modules that indicate that they are in an inoperable state.
- Ensure that the effect on un-repaired equipment is taken into account in your risk assessment.
- Make all necessary repairs to equipment before re-starting, or continuing service of, your machine.

**Failure to follow these instructions can result in death, serious injury, or equipment damage.**

## Inputs - Thermocouple

Error detection for safe inputs of type: Thermocouple

Potential error	Detection	Comment
Non-wired inputs	Detected	Module switches to the defined safe state, page 63.
Short circuit between T+ or T- and external 24 V or GND	Not detected	Signal distortion does not result due to the electrical isolation of the channels; nevertheless, it is mandatory to use shielded signal lines.
Short circuit between T+ and T-	Not detected	This error results in signal distortion that may be detected by two-channel evaluation in some circumstances.
Reverse polarity of T+ and T-	Not detected	This error results in signal distortion that may be detected by two-channel evaluation in some circumstances.
Disturbance voltage	Not detected	This error results in signal distortion that may be detected by two-channel evaluation in some circumstances. Shielded cables are mandatory for the signal lines.  Different installation paths must be used for the wiring of both signals of the signal pair.

**NOTE:** You must take appropriate measures to ensure that this error does not lead to a safety-critical state.

**NOTE:** Signal and supply lines must be installed in accordance with EN ISO 13849-2:2010, Table D.5.

## Inputs - PT100 / PT1000

Error detection for safe inputs of type: PT100 / PT1000

Potential error	Detection	Comment
Open circuit on Sense+ or Sense-	Detected	General indication for one or more non-wired channels.
Short circuit between Sense+, Sense- and external 24 V or GND	Not detected	Signal distortion usually does not result due to the electrical isolation of the channels; nevertheless, it is mandatory to use shielded signal lines.
Short circuit between Sense+ and Sense-	Detected	General indication for one or more non-wired channels.
Disturbance voltage	Not detected	This error results in signal distortion that may be detected by two-channel evaluation in some circumstances. Shielded cables are mandatory for the signal lines.  Different installation paths must be used for the wiring of both signals of the signal pair.

**NOTE:** You must take appropriate measures to ensure that this error does not lead to a defined safe state.

**NOTE:** Signal and supply lines must be installed in accordance with EN ISO 13849-2:2010, Table D.5.

## Defined Safe State

When opening the thermocouple inputs, the module switches into the defined safe state.

Step	Action
1	Switch off the module.
2	Each open thermocouple input of the module has to be wired with one jumper. <b>Result:</b> The module can be switched on again.

### Signal Errors

*HW\_LIMIT\_MIN* designates the lower limit and *HW\_LIMIT\_MAX* designates the upper limit of the measurement range specified in the chapter TM5STI4ATCFS Presentation, page 193.

Signal evaluation takes place in three stages:

Stage 1: Evaluation of signals against absolute time limits

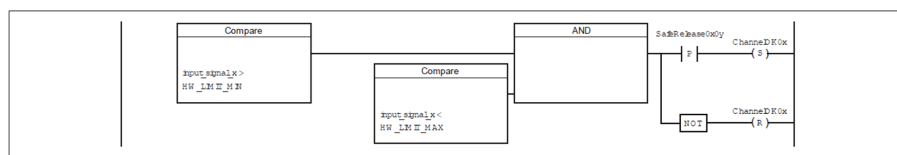

Stage 2: Evaluation of signals against configurable time limits

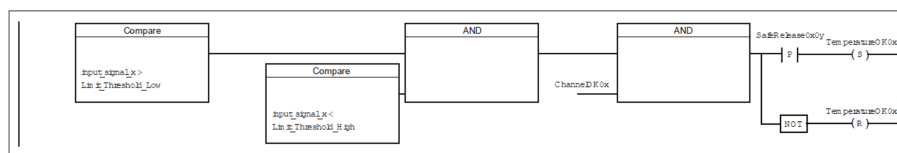

Stage 3: Evaluation of signals against configurable signal pair limits

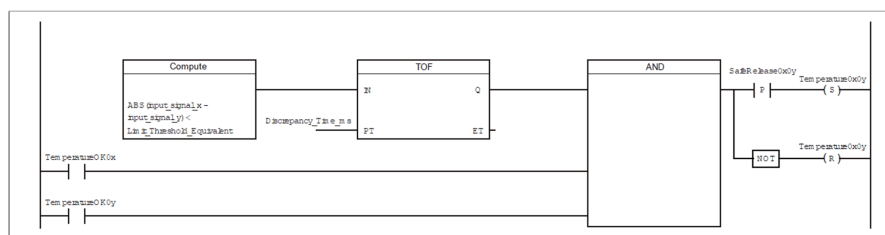

A reset must be performed in order to leave an error state. For this, a valid signal must be received at the analog input for the duration of the I/O update time. The error can then be acknowledged by a rising edge of the signal *SafeRelease0x0y*.

### Channel Diagnostics

Channel electronics are automatically tested internally by the module. A test signal is generated in the module and applied to each channel once every 75 minutes for a maximum time of 1 s. To avoid signal distortion, the signal value of the channel being tested is held in a static state during this time. Only one channel is tested at a time. In accordance with EN IEC 61508:2010, the module is considered as a one out of two diagnostic system for the duration of the channel test.

In firmware version 322 and greater, the behavior for the duration of channel diagnostics is structured as follows:

The safe analog input channels (data type SAFEINT) are constituted as the arithmetic mean value of the two individual signals. For the duration of channel diagnostics, however, it is not the arithmetic mean value that is used, but the signal value of the channel that is not currently being diagnosed. An active channel test is indicated by channel *TestActive*.



## Channel Diagnostic Sequence

The sequence for channel diagnostic is independent of the firmware version and structured as follows:

Diagnostic window	Time sequence	Channel sequence
Diagnostic window 1	Every 75 min	TC1, Sense 1
Diagnostic window 2	15 min after diagnostic window 1	TC4, Sense 2
Diagnostic window 3	30 min after diagnostic window 1	TC3
Diagnostic window 4	45 min after diagnostic window 1	TC4

For further information about variables and parameters refer to .

## Module Functions - TM5STI4ATCFS Safety Module 2x2AI Thermocouple

### Overview

The signal taken via the input terminals is smoothed by the hardware filter (first-order low-pass / cutoff frequency 500 Hz) and digitalized in the subsequent A/D converters.

The filter values configured in the software (refer to ) are applied during digitalization in the A/D converter. The signals then pass through the three stages of digital signal processing. The safe analog input channels (data type SAFEINT) are constituted as the arithmetic mean value of the two individual signals. Also refer to channel diagnostics, page 64.

The validity of analog signals is represented by the associated status signals. These binary status signals (data type SAFEBOOL) must also be evaluated each time the analog signals are used. A binary status signal with the status FALSE indicates an invalid value in the analog signal. When this occurs, the analog signal is no longer permitted to be used for safety-related assessments.

A reset must be performed in order to leave an error state. For this, a valid signal must be received at the analog input for the duration of the I/O update time. The error can then be acknowledged by a rising edge of the signal *SafeRelease0x0y*.

## Input Circuit Diagram - TM5STI4ATCFS Safety Module 2x2AI Thermocouple

### Overview

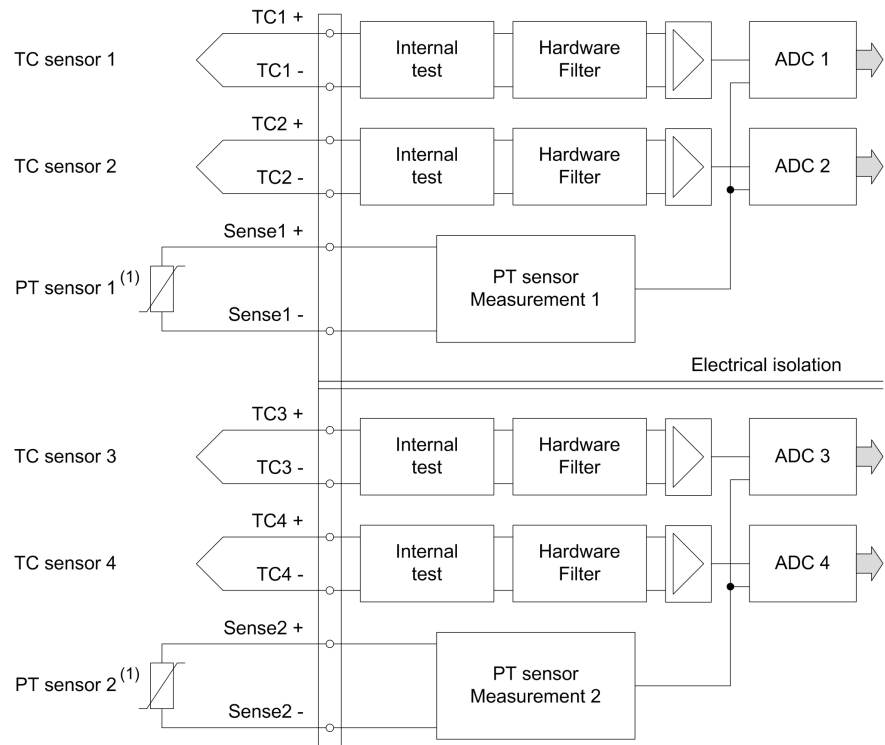

(1) Depending on the type of connection of the thermocouples either terminal block *TM5ACTB5FFS* or *TM5ACTB5EFS* must be used.

---

# TM5/TM7 Safety Digital Input Modules

## What's in This Part

TM5SDI2DFS Safety Module 2DI 24 Vdc Sink .....	68
TM5SDI4DFS Safety Module 4DI 24 Vdc Sink .....	76
TM5SDI20DFS Safety Module 20DI 24 Vdc Sink .....	84
TM7SDI8DFS Safety Module 8DI 24 Vdc .....	92

# TM5SDI2DFS Safety Module 2DI 24 Vdc Sink

## What's in This Chapter

TM5SDI2DFS Presentation ..... 68  
 TM5SDI2DFS Characteristics ..... 71  
 TM5SDI2DFS Wiring ..... 75

## TM5SDI2DFS Presentation

### Main Features

The following table describes the main features of the Safety Digital Input module TM5SDI2DFS:

Main Features	
Number of Inputs	2 safety-related digital inputs
Input Type	configurable input filters, software input filter can be set by channel
Output Type	2 test (pulse) outputs
Signal Type	sink
Rated Voltage	24 Vdc

### **⚠ DANGER**

#### **POTENTIAL FOR EXPLOSION**

- Only use this equipment in non-hazardous locations or in locations that comply with Class I, Division 2, Groups A, B, C and D.
- Do not substitute components which would impair compliance to Class I, Division 2.
- Do not connect or disconnect equipment unless power has been removed or the location is known to be non-hazardous.

**Failure to follow these instructions will result in death or serious injury.**

## Ordering Information

The following figure presents the module in combination with the required components:

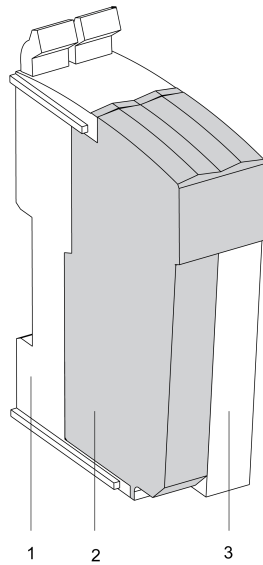

The following table presents the reference of the module:

Number	Reference	Description	Color
2	TM5SDI2DFS	TM5 Safety Digital Input module	red

The following table presents the references for the required components:

Number	Reference	Description	Color
1	TM5ACBM3FS	TM5 Safety bus base, safety coded, internal I/O supply is interconnected	red
3	TM5ACTB52FS	TM5 Safety terminal block, 12-pin, safety coded	red

**NOTE:** A TM5 Safety bus base and a TM5 Safety terminal block are required for operation of the module, and are sold separately. For more information, refer to TM5ACBM3FS Safety bus base, page 232 and TM5ACTB52FS Safety terminal block, page 238.

## Status LED Indicators

This figure presents the TM5SDI2DFS status LED indicators:

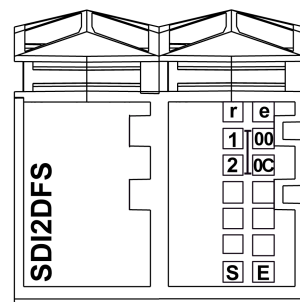

The following tables describe the status LED indicators:

LED indicator	Color	Status	Description
r	off		Module supply not connected.

LED indicator	Color	Status	Description
	green	single flash	reset mode
		double flash	firmware update in progress
		flashing	pre-operational state
		on	RUN state
e	off		No error detected or module supply not connected.
	red	flashing	boot loader mode
		triple flash	firmware update in progress
		on	error detected
r+e	steady red/single green flash		invalid configuration

LED indicator	Color	Status	Description
1 2	red	on	Indicates either an error has been detected for the corresponding input or that the safety-related input is being used as a non-safety-related input. <b>NOTE:</b> When there is no connection to the Safety Logic Controller, all channels are steady red.
	green	on	input set
OO			open - open: 2-channel evaluation on channels 1 and 2. <b>NOTE:</b> Detected errors in the two-channel evaluation will be indicated by means of the individual channel LED indicators.
	red	on	Indicates a detected evaluation channel error.
	green	on	Evaluation channel is set.
OC			open - closed: 2 channel evaluation on channels 1 and 2. <b>NOTE:</b> Detected errors in the two-channel evaluation will be indicated by means of the individual channel LED indicators.
	red	on	Indicates a detected evaluation channel error.
	green	on	Evaluation channel is set.

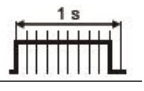
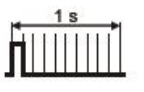
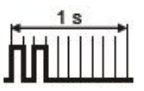
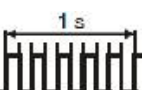
LED indicator	Color	Status	Description
S E	off		RUN state or 24 Vdc supply not present
	red		boot phase or missing TM5 link or non-functioning processor (refer to safety message below)
			pre-operational state
			communication channel is not OK
			firmware for this module is a non-certified pilot version <b>NOTE:</b> If you observe this indication, you must immediately replace the module, or update its firmware with a certified version. In all cases, contact your Schneider Electric representative.

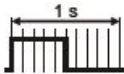
LED indicator	Color	Status	Description
			boot phase, inoperable firmware
		on	Safety-related status is active.

Whenever the **S** and **E** LED indicators are illuminated continuously, this indicates that the module is inoperable. There is also a diagnostic available in the Safety Logic Controller to indicate this state. Replacement of the module must be made immediately. It is your responsibility to ensure all necessary repairs are made promptly to enable proper functionality.

<b>⚠ WARNING</b>
<p><b>LOSS OF SAFETY FUNCTION</b></p> <ul style="list-style-type: none"> <li>• Immediately replace any and all modules that indicate that they are in an inoperable state.</li> <li>• Ensure that the effect on un-repaired equipment is taken into account in your risk assessment.</li> <li>• Make all necessary repairs to equipment before re-starting, or continuing service of, your machine.</li> </ul> <p><b>Failure to follow these instructions can result in death, serious injury, or equipment damage.</b></p>

## TM5SDI2DFS Characteristics

### Introduction

This section describes the characteristics of the TM5SDI2DFS module. See also TM5 Environmental Characteristics, page 26.

<b>⚠ DANGER</b>
<p><b>FIRE HAZARD</b></p> <p>Use only the correct wire sizes for the maximum current capacity of the I/O channels and power supplies.</p> <p><b>Failure to follow these instructions will result in death or serious injury.</b></p>

<b>⚠ WARNING</b>
<p><b>UNINTENDED EQUIPMENT OPERATION</b></p> <p>Do not exceed any of the rated values specified in the environmental and electrical characteristics tables.</p> <p><b>Failure to follow these instructions can result in death, serious injury, or equipment damage.</b></p>

### General Characteristics

The following table lists the general characteristics of the TM5SDI2DFS module:

General Characteristics	
Rated power supply voltage	24 Vdc
Status indicators	• I/O functions per channel

General Characteristics		
		<ul style="list-style-type: none"> <li>operating state</li> <li>module status</li> </ul>
Diagnostics		Module run and detected error conditions indicated by status LED indicator and software status.
Electrical isolation <sup>1)</sup>	channel - bus	See note.
	channel - channel	no galvanic isolation
TM5 Bus 5 Vdc current draw		50 mA
24 Vdc I/O segment current draw		41.7 mA
Certifications and standards		<ul style="list-style-type: none"> <li>CE</li> <li>UL508 (ULus)</li> <li>IEC 61508</li> <li>IEC 62061</li> <li>EN 13849</li> </ul>
Maximum internal cycle time		800 µs
Minimum cycle time		200 µs
Minimum I/O update time		400 µs
Minimum safety-related response time		6 ms
Id code for firmware update		7957 dec

**NOTE** <sup>(1)</sup> The isolation of the electronic module is 500 Vac RMS between the electronics power by the TM5 bus and those powered by 24 Vdc I/O power segment connected to the module. In practice, the electronic module is installed in the bus base, and there is a bridge between the TM5 power bus and the 24 Vdc I/O power segment. The two power circuits reference the same functional ground (FE) through specific components designed to reduce effects of electromagnetic interference. These components are rated at 30 Vdc or 60 Vdc. This effectively reduces isolation of the entire system from the 500 Vac RMS.

## Operating Conditions

The following table lists the operating conditions for the TM5SDI2DFS module:

Operating Conditions		
Mounting orientation		horizontal or vertical
Operating temperature	horizontal installation	0...+55 °C (+32...131 °F), possibility of derating bonus, see note.
	vertical installation	0...+50 °C (+32...122 °F)
Relative humidity		5...95%
Installation at altitudes above sea level:	0 up to 2000 m (0 up to 6561 ft)	no derating for altitude
	> 2000 m (>6561 ft)	reduction of ambient temperature by 0.5 °C per 100 m (0.9 °F per 328 ft)
EN 60529 Protection type		IP20

**NOTE:** If a TM5SD000 is installed on the side of the module, the horizontal installation derating is shifted to the right by the following derating bonus:

- TM5SD000 to the left: +0 °C (+0 °F)
- TM5SD000 to the right: +2.5 °C (+4.5 °F)
- TM5SD000 to the left and right: +5 °C (+9 °F)



## Storage and Transport Conditions

The following table lists the storage and transport conditions for the TM5SDI2DFS module:

Storage and Transport Conditions	
Temperature	-25...+70 °C (-13...+158 °F)
Relative humidity	5...95%

## Digital Input Characteristics

The following table lists the digital input characteristics of the TM5SDI2DFS module:

Digital Input		
Number of input channels		2
Rated voltage		24 Vdc
Input filter	hardware	≤150 µs
	software	default: 0 ms, configurable between 0 and 500 ms
Input circuit		sink
Input voltage range		20.4...28.8 Vdc
Input current at 24 Vdc		typical: 3.45 mA
Input resistance		typical: 7 kΩ
OFF state (switching threshold low)		<5 Vdc
ON state (switching threshold high)		>15 Vdc
Isolation voltage between channel and bus <sup>1)</sup>		See note.
Error detection time		100 ms

**NOTE** <sup>(1)</sup> The isolation of the electronic module is 500 Vac RMS between the electronics power by the TM5 bus and those powered by 24 Vdc I/O power segment connected to the module. In practice, the electronic module is installed in the bus base, and there is a bridge between the TM5 power bus and the 24 Vdc I/O power segment. The two power circuits reference the same functional ground (FE) through specific components designed to reduce effects of electromagnetic interference. These components are rated at 30 Vdc or 60 Vdc. This effectively reduces isolation of the entire system from the 500 Vac RMS.

## Digital Test (Pulse) Output Characteristics

The following table lists the digital test (pulse) output characteristics of the TM5SDI2DFS module:

Digital test (pulse) outputs	
Design	push-pull
Switching voltage	24 Vdc (-15% / +20%)
Rated output current	100 mA
Total current	200 mA
Output protection	disable all channels when overload or short circuit.
Leakage current when switched off	Maximum 25 µA
Residual voltage	Maximum 0.6 V at 100 mA
Short circuit peak current	300 mA

Digital test (pulse) outputs	
Diagnostics status	output monitoring
Maximum cable length	50 m / 164 ft (shielded)

## Safety-Related Characteristics

The following table lists the safety-related characteristics of the TM5SDI2DFS module:

Criteria	Characteristic Value
Maximum performance level according to EN ISO 13849	PL e
Category according to EN ISO 13849	CAT 3 when using individual input channels CAT 4 when using input channel pairs (for example SI1 and SI2) or more
Maximum safety integrity level according to IEC 62061	SIL 3
Maximum safety integrity level according to IEC 61508	SIL 3
PFH	$<1 \cdot 10^{-10}$
PFD	<ul style="list-style-type: none"> <li>• <math>&lt;1 \cdot 10^{-5}</math> at a proof test interval of 10 years</li> <li>• <math>&lt;2 \cdot 10^{-5}</math> at a proof test interval of 20 years</li> </ul>
PT	Maximum 20 years
DC	>94%
SFF	>90%
MTTFd	2500 years
Life time, page 26	20 years

# TM5SDI2DFS Wiring

## Pin Assignments / Connection Example

The following figure presents a connection example for the TM5SDI2DFS:

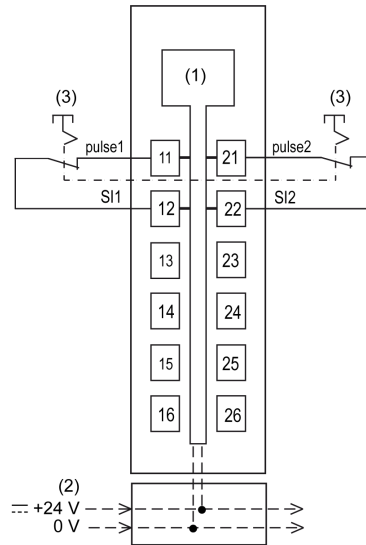

- 1 Internal electronics
- 2 24 Vdc I/O power segment integrated into the bus bases
- 3 2-wire sensor

<b>⚠ WARNING</b>
<p><b>UNINTENDED EQUIPMENT OPERATION</b></p> <p>Do not connect wires to unused terminals and/or terminals indicated as “No Connection (N.C.)”.</p> <p><b>Failure to follow these instructions can result in death, serious injury, or equipment damage.</b></p>

<b>⚠ WARNING</b>
<p><b>UNINTENDED EQUIPMENT OPERATION</b></p> <p>Only use the test (pulse) outputs for the intended purpose of connecting them to the module inputs.</p> <p><b>Failure to follow these instructions can result in death, serious injury, or equipment damage.</b></p>

# TM5SDI4DFS Safety Module 4DI 24 Vdc Sink

## What's in This Chapter

TM5SDI4DFS Presentation ..... 76  
 TM5SDI4DFS Characteristics ..... 79  
 TM5SDI4DFS Wiring ..... 83

## TM5SDI4DFS Presentation

### Main Features

The following table describes the main features of the Safety Digital Input module TM5SDI4DFS:

Main Features	
Number of Inputs	4 safety-related digital inputs
Input Type	configurable input filters, software input filter can be set by channel
Output Type	4 test (pulse) outputs
Signal Type	sink
Rated Voltage	24 Vdc

## ⚠ DANGER

### POTENTIAL FOR EXPLOSION

- Only use this equipment in non-hazardous locations or in locations that comply with Class I, Division 2, Groups A, B, C and D.
- Do not substitute components which would impair compliance to Class I, Division 2.
- Do not connect or disconnect equipment unless power has been removed or the location is known to be non-hazardous.

**Failure to follow these instructions will result in death or serious injury.**

## Ordering Information

The following figure presents the module in combination with the required components:

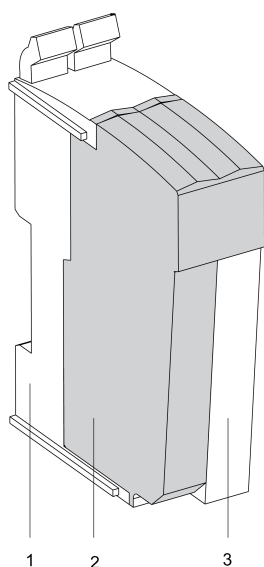

The following table presents the reference of the module:

Number	Reference	Description	Color
2	TM5SDI4DFS	TM5 Safety Digital Input module	red

The following table presents the references for the required components:

Number	Reference	Description	Color
1	TM5ACBM3-FS	TM5 Safety bus base, safety coded, internal I/O supply is interconnected	red
3	TM5ACTB52-FS	TM5 Safety terminal block, 12-pin, safety coded	red

**NOTE:** A TM5 Safety bus base and a TM5 Safety terminal block are required for operation of the module, and are sold separately. For more information, refer to TM5ACBM3FS Safety bus base, page 232 and TM5ACTB52FS Safety terminal block, page 238.

## Status LED Indicators

This figure presents the TM5SDI4DFS status LED indicators:

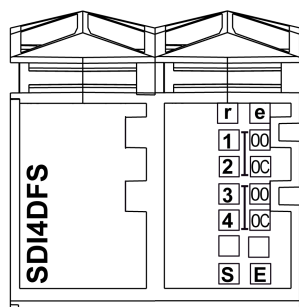

The following tables describe the status LED indicators:

LED indicator	Color	Status	Description
r	off		Module supply not connected.
	green	single flash	reset mode

LED indicator	Color	Status	Description
		double flash	firmware update in progress
		flashing	pre-operational state
		on	RUN state
e	off		No error detected or module supply not connected.
	red	flashing	boot loader mode
		triple flash	firmware update in progress
		on	error detected
r+e	steady red/single green flash		invalid configuration

LED indicator	Color	Status	Description
1 2 3 4	red	on	Indicates either an error has been detected for the corresponding input or that the safety-related input is being used as a non-safety-related input.  <b>NOTE:</b> When there is no connection to the Safety Logic Controller, all channels are steady red.
	green	on	input set
OO			open - open: 2-channel evaluation on channels 1 and 2, or channels 3 and 4.  <b>NOTE:</b> Detected errors in the two-channel evaluation will be indicated by means of the individual channel LED indicators.
	red	on	Indicates a detected evaluation channel error.
	green	on	Evaluation channel is set.
OC			open - closed: 2 channel evaluation on channels 1 and 2, or channels 3 and 4.  <b>NOTE:</b> Detected errors in the two-channel evaluation will be indicated by means of the individual channel LED indicators.
	red	on	Indicates a detected evaluation channel error.
	green	on	Evaluation channel is set.

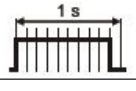
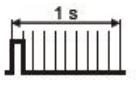
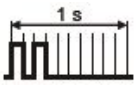
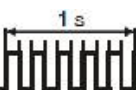
LED indicator	Color	Status	Description
S E	off		RUN state or 24 Vdc supply not present
	red		boot phase or missing TM5 link or non-functioning processor (refer to safety message below)
			pre-operational state
			communication channel is not OK
			firmware for this module is a non-certified pilot version  <b>NOTE:</b> If you observe this indication, you must immediately replace the module, or update its firmware with a certified version. In all cases, contact your Schneider Electric representative.

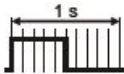
LED indicator	Color	Status	Description
			boot phase, inoperable firmware
		on	Safety-related status is active.

Whenever the **S** and **E** LED indicators are illuminated continuously, this indicates that the module is inoperable. There is also a diagnostic available in the Safety Logic Controller to indicate this state. Replacement of the module must be made immediately. It is your responsibility to ensure all necessary repairs are made promptly to enable proper functionality.

<b>⚠ WARNING</b>
<p><b>LOSS OF SAFETY FUNCTION</b></p> <ul style="list-style-type: none"> <li>• Immediately replace any and all modules that indicate that they are in an inoperable state.</li> <li>• Ensure that the effect on un-repaired equipment is taken into account in your risk assessment.</li> <li>• Make all necessary repairs to equipment before re-starting, or continuing service of, your machine.</li> </ul> <p><b>Failure to follow these instructions can result in death, serious injury, or equipment damage.</b></p>

## TM5SDI4DFS Characteristics

### Introduction

This section describes the characteristics of the TM5SDI4DFS module. See also TM5 Environmental Characteristics, page 26.

<b>⚠ DANGER</b>
<p><b>FIRE HAZARD</b></p> <p>Use only the correct wire sizes for the maximum current capacity of the I/O channels and power supplies.</p> <p><b>Failure to follow these instructions will result in death or serious injury.</b></p>

<b>⚠ WARNING</b>
<p><b>UNINTENDED EQUIPMENT OPERATION</b></p> <p>Do not exceed any of the rated values specified in the environmental and electrical characteristics tables.</p> <p><b>Failure to follow these instructions can result in death, serious injury, or equipment damage.</b></p>

### General Characteristics

The following table lists the general characteristics of the TM5SDI4DFS module:

General Characteristics	
Rated power supply voltage	24 Vdc
Status indicators	<ul style="list-style-type: none"> <li>• I/O functions per channel</li> </ul>

General Characteristics		
		<ul style="list-style-type: none"> <li>operating state</li> <li>module status</li> </ul>
Diagnostics		Module run and detected error conditions indicated by status LED indicator and software status.
Electrical isolation <sup>1)</sup>	channel - bus	See note.
	channel - channel	no galvanic isolation
TM5 Bus 5 Vdc current draw		64 mA
24 Vdc I/O segment current draw		52.1 mA
Certifications and standards		<ul style="list-style-type: none"> <li>CE</li> <li>UL508 (ULus)</li> <li>IEC 61508</li> <li>IEC 62061</li> <li>EN 13849</li> </ul>
Maximum internal cycle time		800 µs
Minimum cycle time		200 µs
Minimum I/O update time		400 µs
Minimum safety-related response time		6 ms
Id code for firmware update		7613 dec

**NOTE** <sup>(1)</sup> The isolation of the electronic module is 500 Vac RMS between the electronics power by the TM5 bus and those powered by 24 Vdc I/O power segment connected to the module. In practice, the electronic module is installed in the bus base, and there is a bridge between the TM5 power bus and the 24 Vdc I/O power segment. The two power circuits reference the same functional ground (FE) through specific components designed to reduce effects of electromagnetic interference. These components are rated at 30 Vdc or 60 Vdc. This effectively reduces isolation of the entire system from the 500 Vac RMS.

## Operating Conditions

The following table lists the operating conditions for the TM5SDI4DFS module:

Operating Conditions		
Mounting orientation		horizontal or vertical
Operating temperature	horizontal installation	0...+55 °C (+32...131 °F), possibility of derating bonus, see note.
	vertical installation	0...+50 °C (+32...122 °F)
Relative humidity		5...95%
Installation at altitudes above sea level:	0 up to 2000 m (0 up to 6561 ft)	no derating for altitude
	> 2000 m (>6561 ft)	reduction of ambient temperature by 0.5 °C per 100 m (0.9 °F per 328 ft)
EN 60529 Protection type		IP20

**NOTE:** If a TM5SD000 is installed on the side of the module, the horizontal installation derating is shifted to the right by the following derating bonus:

- TM5SD000 to the left: +0 °C (+0 °F)
- TM5SD000 to the right: +2.5 °C (+4.5 °F)
- TM5SD000 to the left and right: +5 °C (+9 °F)



## Storage and Transport Conditions

The following table lists the storage and transport conditions for the TM5SDI4DFS module:

Storage and Transport Conditions	
Temperature	-25...+70 °C (-13...+158 °F)
Relative humidity	5...95%

## Digital Input Characteristics

The following table lists the digital input characteristics of the TM5SDI4DFS module:

Digital Input		
Number of input channels	4	
Rated voltage	24 Vdc	
Input filter	hardware	≤150 µs
	software	default: 0 ms, configurable between 0 and 500 ms
Input circuit	sink	
Input voltage range	20.4...28.8 Vdc	
Input current at 24 Vdc	typical: 3.45 mA	
Input resistance	typical: 7 kΩ	
OFF state (switching threshold low)	<5 Vdc	
ON state (switching threshold high)	>15 Vdc	
Isolation voltage between channel and bus <sup>1)</sup>	See note.	
Error detection time	100 ms	

**NOTE** <sup>(1)</sup> The isolation of the electronic module is 500 Vac RMS between the electronics power by the TM5 bus and those powered by 24 Vdc I/O power segment connected to the module. In practice, the electronic module is installed in the bus base, and there is a bridge between the TM5 power bus and the 24 Vdc I/O power segment. The two power circuits reference the same functional ground (FE) through specific components designed to reduce effects of electromagnetic interference. These components are rated at 30 Vdc or 60 Vdc. This effectively reduces isolation of the entire system from the 500 Vac RMS.

## Digital Test (Pulse) Output Characteristics

The following table lists the digital test (pulse) output characteristics of the TM5SDI4DFS module:

Digital test (pulse) outputs	
Design	push-pull
Switching voltage	24 Vdc (-15% / +20%)
Rated output current	100 mA
Total current	400 mA
Output protection	disable all channels when overload or short circuit.
Leakage current when switched off	Maximum 25 µA
Residual voltage	Maximum 0.6 V at 100 mA
Short circuit peak current	300 mA

Digital test (pulse) outputs	
Diagnostics status	output monitoring
Maximum cable length	50 m / 164 ft (shielded)

## Safety-Related Characteristics

The following table lists the safety-related characteristics of the TM5SDI4DFS module:

Criteria	Characteristic Value
Maximum performance level according to EN ISO 13849	PL e
Category according to EN ISO 13849	CAT 3 when using individual input channels CAT 4 when using input channel pairs (for example SI1 and SI2) or more
Maximum safety integrity level according to IEC 62061	SIL 3
Maximum safety integrity level according to IEC 61508	SIL 3
PFH	$<1 \cdot 10^{-10}$
PFD	<ul style="list-style-type: none"> <li>• <math>&lt;1 \cdot 10^{-5}</math> at a proof test interval of 10 years</li> <li>• <math>&lt;2 \cdot 10^{-5}</math> at a proof test interval of 20 years</li> </ul>
PT	Maximum 20 years
DC	>94%
SFF	>90%
MTTFd	2500 years
Life time, page 26	20 years

# TM5SDI4DFS Wiring

## Pin Assignments / Connection Example

The following figure presents a connection example for the TM5SDI4DFS:

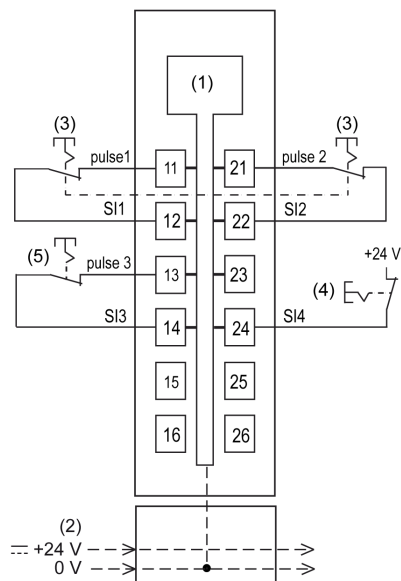

- 1 Internal electronics
- 2 24 Vdc I/O power segment integrated into the bus bases
- 3 2-wire sensor
- 4 single wire sensor, external power supply
- 5 single wire sensor, internally supplied by test (pulse) output

**NOTE:** When connecting a sensor via an external power supply, it must be the same source as that of the 24 Vdc I/O power segment.

<b>⚠ WARNING</b>
<p><b>UNINTENDED EQUIPMENT OPERATION</b></p> <p>Do not connect wires to unused terminals and/or terminals indicated as “No Connection (N.C.)”.</p> <p><b>Failure to follow these instructions can result in death, serious injury, or equipment damage.</b></p>

<b>⚠ WARNING</b>
<p><b>UNINTENDED EQUIPMENT OPERATION</b></p> <p>Only use the test (pulse) outputs for the intended purpose of connecting them to the module inputs.</p> <p><b>Failure to follow these instructions can result in death, serious injury, or equipment damage.</b></p>

# TM5SDI20DFS Safety Module 20DI 24 Vdc Sink

## What's in This Chapter

TM5SDI20DFS Presentation ..... 84  
 TM5SDI20DFS Characteristics ..... 86  
 TM5SDI20DFS Wiring ..... 90

## TM5SDI20DFS Presentation

### Main Features

The following table describes the main features of the Safety Digital Input module TM5SDI20DFS:

Main Features	
Number of inputs	20 safety-related digital inputs
Input type	configurable input filters, software input filter can be set by channel
Output type	4 test (pulse) outputs
Signal type	sink
Rated voltage	24 Vdc

This equipment has been designed to operate outside of any hazardous location. Only install this equipment in zones known to be free of a hazardous atmosphere.

<b>⚠ DANGER</b>
<b>POTENTIAL FOR EXPLOSION</b>
Install and use this equipment in non-hazardous locations only.
<b>Failure to follow these instructions will result in death or serious injury.</b>

### Ordering Information

The following figure presents the module in combination with the required components:

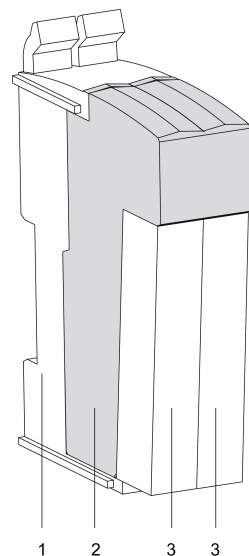

The following table presents the reference of the module:

Number	Reference	Description	Color
2	TM5SDI20DFS	TM5 Safety Digital Input module	red

The following table presents the references for the required components:

Number	Reference	Description	Color
1	TM5ACBM3-FS	TM5 Safety bus base, safety coded, internal I/O supply is interconnected	red
3	TM5ACTB52-FS	TM5 Safety terminal block, 12-pin, safety coded	red

**NOTE:** A TM5 Safety bus base and a TM5 Safety terminal block are required for operation of the module, and are sold separately. For more information, refer to TM5ACBM3FS Safety bus base, page 232 and TM5ACTB52FS Safety terminal block, page 238.

### Status LED Indicators

This figure presents the TM5SDI20DFS status LED indicators:

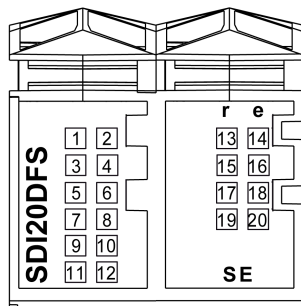

The following tables describe the status LED indicators:

LED indicator	Color	Status	Description
r	off		Module supply not connected.
	green	single flash	reset mode
		double flash	firmware update in progress
		flashing	pre-operational state
		on	RUN state
e	off		No error detected or module supply not connected.
	red	flashing	boot loader mode
		triple flash	firmware update in progress
		on	error detected
r+e	steady red/single green flash		invalid configuration

LED indicator	Color	Status	Description
1 ... 20	red	on	Indicates either an error has been detected for the corresponding input or that the safety-related input is being used as a non-safety-related input. <b>NOTE:</b> When there is no connection to the Safety Logic Controller, all channels are steady red.
		flashing	detected error in 2-channel evaluation (synchronous flashing of two affected channels).
		green	on

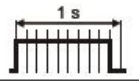
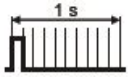
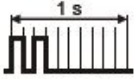
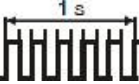
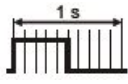
LED indicator	Color	Status	Description
S E	off		RUN state or 24 Vdc supply not present
	red		boot phase or missing TM5 link or non-functioning processor (refer to safety message below)
			pre-operational state
			communication channel is not OK
			firmware for this module is a non-certified pilot version <b>NOTE:</b> If you observe this indication, you must immediately replace the module, or update its firmware with a certified version. In all cases, contact your Schneider Electric representative.
			boot phase, inoperable firmware
	on		Safety-related status is active.

Whenever the **S** and **E** LED indicators are illuminated continuously, this indicates that the module is inoperable. There is also a diagnostic available in the Safety Logic Controller to indicate this state. Replacement of the module must be made immediately. It is your responsibility to ensure all necessary repairs are made promptly to enable proper functionality.

**⚠ WARNING**

**LOSS OF SAFETY FUNCTION**

- Immediately replace any and all modules that indicate that they are in an inoperable state.
- Ensure that the effect on un-repaired equipment is taken into account in your risk assessment.
- Make all necessary repairs to equipment before re-starting, or continuing service of, your machine.

**Failure to follow these instructions can result in death, serious injury, or equipment damage.**

## TM5SDI20DFS Characteristics

### Introduction

This section describes the characteristics of the TM5SDI20DFS module. See also TM5 Environmental Characteristics, page 26.

**⚠ DANGER**

**FIRE HAZARD**

Use only the correct wire sizes for the maximum current capacity of the I/O channels and power supplies.

**Failure to follow these instructions will result in death or serious injury.**

▲ WARNING
UNINTENDED EQUIPMENT OPERATION
Do not exceed any of the rated values specified in the environmental and electrical characteristics tables.
Failure to follow these instructions can result in death, serious injury, or equipment damage.

## General Characteristics

The following table lists the general characteristics of the TM5SDI20DFS module:

General characteristics		
Rated power supply voltage	24 Vdc	
Status indicators	<ul style="list-style-type: none"> <li>I/O functions per channel</li> <li>operating state</li> <li>module status</li> </ul>	
Diagnostics	Module run and detected error conditions indicated by status LED indicator and software status.	
Electrical isolation <sup>1)</sup>	channel - bus	See note.
	channel - channel	no galvanic isolation
TM5 Bus 5 Vdc current draw	80 mA	
24 Vdc I/O segment current draw	66.7 mA	
Certifications and standards	<ul style="list-style-type: none"> <li>CE</li> <li>cULus</li> <li>KC</li> <li>EN IEC 61508:2010</li> <li>EN IEC 62061:2010</li> <li>EN ISO 13849-1:2008</li> <li>EN IEC 61511:2004</li> <li>EN 50156-1:2004</li> </ul>	
Maximum internal cycle time	1600 µs	
Minimum cycle time	200 µs	
Minimum I/O update time	800 µs	
Id code for firmware update	44744 dec	

**NOTE** <sup>(1)</sup> The isolation of the electronic module is 500 Vac RMS between the electronics power by the TM5 bus and those powered by 24 Vdc I/O power segment connected to the module. In practice, the electronic module is installed in the bus base, and there is a bridge between the TM5 power bus and the 24 Vdc I/O power segment. The two power circuits reference the same functional ground (FE) through specific components designed to reduce effects of electromagnetic interference. These components are rated at 30 Vdc or 60 Vdc. This effectively reduces isolation of the entire system from the 500 Vac RMS.

## Operating Conditions

The following table lists the operating conditions for the TM5SDI20DFS module:

Operating conditions		
Mounting orientation	horizontal or vertical	
Operating temperature	horizontal installation	0...+55 °C (+32...131 °F), for derating refer to following table <sup>1</sup>

Operating conditions		
	vertical installation	0...+50 °C (+32...122 °F), for derating refer to following table <sup>1</sup>
Relative humidity		5...95%
Installation at altitudes above sea level:	0 up to 2000 m (0 up to 6561 ft)	no derating for altitude
	> 2000 m (>6561 ft)	reduction of ambient temperature by 0.5 °C per 100 m (0.9 °F per 328 ft)
EN 60529 protection type		IP20

<sup>1</sup> Derating in relation to operating temperature and mounting orientation

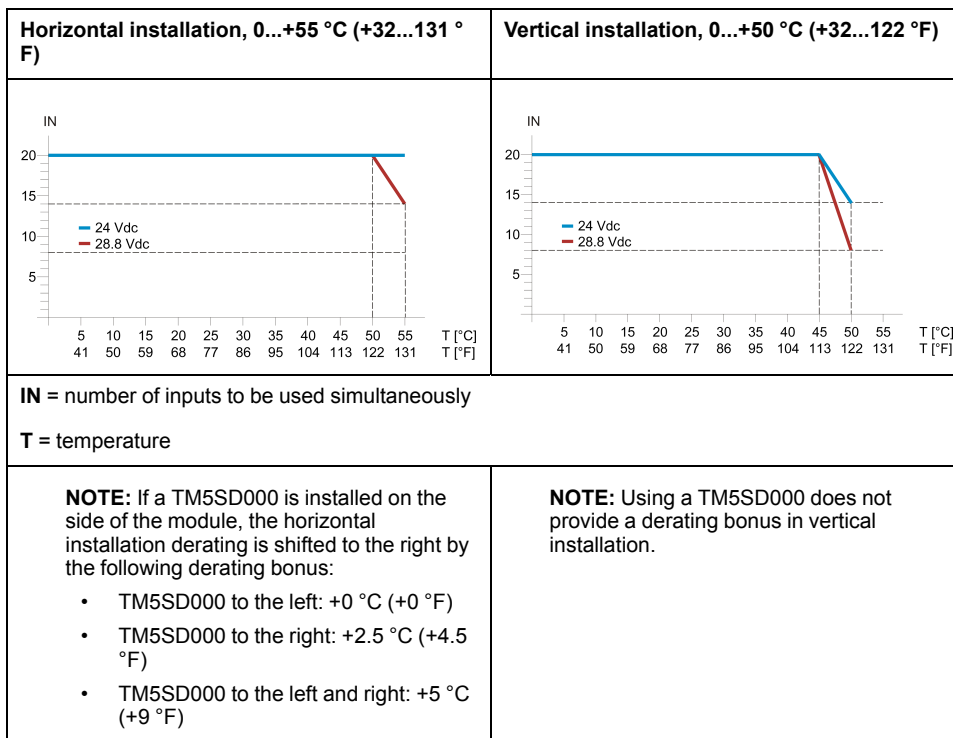

### Storage and Transport Conditions

The following table lists the storage and transport conditions for the TM5SDI20DFS module:

Storage and transport conditions	
Temperature	-25...+70 °C (-13...+158 °F)
Relative humidity	5...95%

### Safety-Related Digital Inputs Characteristics

The following table lists the safety-related digital input characteristics of the TM5SDI20DFS module:

Digital input		
Number of input channels		20
Rated voltage		24 Vdc
Input filter	hardware	≤150 µs
	software	default: 0 ms, configurable 0...500 ms
Input circuit		sink



Digital input	
Input voltage range	20.4...28.8 Vdc
Input current at 24 Vdc	typical: 2.48 mA
Input resistance	typical: 9.68 kΩ
OFF state (switching threshold low)	<5 Vdc
ON state (switching threshold high)	>15 Vdc
Isolation voltage between channel and bus <sup>1)</sup>	See note.
Error detection time	100 ms

**NOTE** <sup>(1)</sup> The isolation of the electronic module is 500 Vac RMS between the electronics power by the TM5 bus and those powered by 24 Vdc I/O power segment connected to the module. In practice, the electronic module is installed in the bus base, and there is a bridge between the TM5 power bus and the 24 Vdc I/O power segment. The two power circuits reference the same functional ground (FE) through specific components designed to reduce effects of electromagnetic interference. These components are rated at 30 Vdc or 60 Vdc. This effectively reduces isolation of the entire system from the 500 Vac RMS.

### Digital Test (Pulse) Output Characteristics

The following table lists the digital test (pulse) output characteristics of the TM5SDI20DFS module:

Digital test outputs	
Design	push-pull
Switching voltage	24 Vdc (-15% / +20%)
Rated output current	50 mA
Total current	200 mA
Output protection	disable individual channels if overcurrent or short circuit occurs
Leakage current when switched off	Maximum 25 μA
Residual voltage	2 Vdc
Short circuit peak current	100 mA
Diagnostics status	output monitoring
Maximum cable length	50 m / 164 ft (shielded)

### Safety-Related Characteristics

The following table lists the safety-related characteristics of the TM5SDI20DFS module:

Criteria	Characteristic value
Maximum performance level according to EN ISO 13849-1:2008	PL e
Category according to EN ISO 13849-1:2008	CAT 3 when using individual input channels CAT 4 when using input channel pairs (for example SI1 and SI2) or more
Maximum safety integrity level according to EN IEC 62061:2010	SIL 3
Maximum safety integrity level according to EN IEC 61508:2010	SIL 3
Maximum safety integrity level according to EN IEC 61511:2004	SIL 3
PFH	<1*10 <sup>-10</sup>

Criteria	Characteristic value
PFD	<ul style="list-style-type: none"> <li>&lt;math&gt;1 \cdot 10^{-5}&lt;/math&gt; at a proof test interval of 10 years</li> <li>&lt;math&gt;2 \cdot 10^{-5}&lt;/math&gt; at a proof test interval of 20 years</li> </ul>
PT	Maximum 20 years
DC	>94%
SFF	>90%
MTTFd	2500 years
Life time, page 26	20 years

## TM5SDI20DFS Wiring

### Pin Assignments / Connection Example

The following figure presents a connection example for the TM5SDI20DFS:

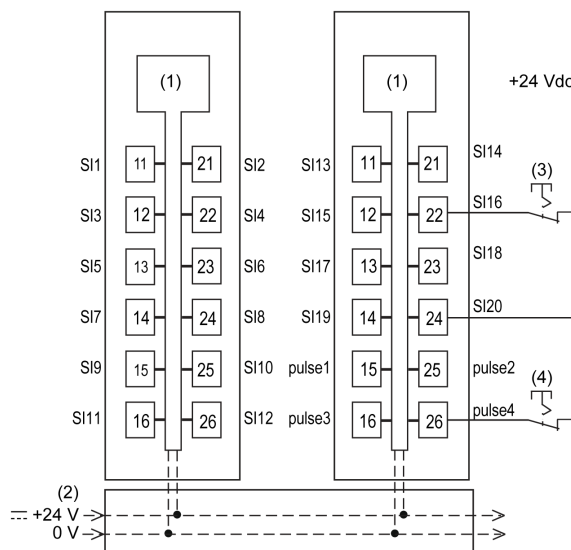

1 Internal electronics

2 24 Vdc I/O power segment integrated into the bus bases

3 Single wire sensor, external power supply

4 Single wire sensor, internally supplied by test (pulse) output

**NOTE:** When connecting a sensor via an external power supply, it must be the same source as that of the 24 Vdc I/O power segment.

### ⚠ WARNING

#### UNINTENDED EQUIPMENT OPERATION

Do not connect wires to unused terminals and/or terminals indicated as "No Connection (N.C.)".

**Failure to follow these instructions can result in death, serious injury, or equipment damage.**

**▲ WARNING****UNINTENDED EQUIPMENT OPERATION**

Only use the test (pulse) outputs for the intended purpose of connecting them to the module inputs.

**Failure to follow these instructions can result in death, serious injury, or equipment damage.**

# TM7SDI8DFS Safety Module 8DI 24 Vdc

## What's in This Chapter

TM7SDI8DFS Presentation .....	92
TM7SDI8DFS Characteristics .....	95
TM7SDI8DFS Wiring .....	99

## TM7SDI8DFS Presentation

### Main Features

The following table describes the main features of the Safety Digital Input module TM7SDI8DFS:

Main features	
Number of inputs	<ul style="list-style-type: none"> <li>• 8 safety-related digital inputs</li> <li>• 2 digital inputs without safety functionality</li> </ul>
Input filter	Configurable input filter, 0...500 ms
Input circuit	Sink
Number of outputs	<ul style="list-style-type: none"> <li>• 2 test (pulse) outputs</li> <li>• 2 digital outputs without safety functionality</li> </ul>
Rated voltage	24 Vdc

## ⚠ DANGER

### POTENTIAL FOR EXPLOSION

- Only use this equipment in non-hazardous locations or in locations that comply with the ATEX Group II, Zone 2 specifications for hazardous locations.
- Do not substitute components which would impair compliance to the ATEX Group II, Zone 2 specifications.
- Do not connect or disconnect equipment unless power has been removed or the location is known to be non-hazardous.

**Failure to follow these instructions will result in death or serious injury.**

### Ordering Information

The following table presents the reference of the module:

Reference	Description	Color
TM7SDI8DFS	TM7 Safety Digital Input module	red

**NOTE:** For more information, refer to:

- TM7 Physical Description, page 35,
- TM7 Block grounding (see PacDrive TM5 / TM7 Flexible System, System Planning and Installation Guide),
- TM7 Installation Guidelines (see Modicon TM7, Digital I/O Blocks, Hardware Guide).

## Status LED Indicators

This figure presents the status LED indicators:

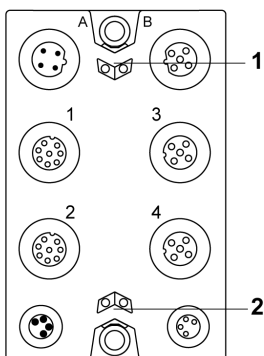

**1** Status LED indicators **r** and **e**: left green **r**, right red **e**



**2** Status LED indicators **S** and **E**: left red **S**, right red **E**

The following tables describe the status LED indicators:

LED indicator	Color	Status	Description
<b>r</b>	off		Module supply not connected.
	green	single flash	reset mode
		double flash	firmware update in progress
		flashing	pre-operational state
<b>e</b>	off		No error detected or module supply not connected.
	red	flashing	boot loader mode
		triple flash	firmware update in progress
		on	error detected
<b>r+e</b>	steady red/single green flash		invalid configuration

LED indicator	Color	Status	Description
<b>1</b>	-		status of the corresponding device
<b>2</b> <b>3</b> <b>4</b>	off		<ul style="list-style-type: none"> <li>Without signal function: No error detected, all signals from female connector off ("low" state).</li> <li>2-channel evaluation: No error detected, 2-channel evaluation FALSE ("low" state).</li> </ul>
		on	<ul style="list-style-type: none"> <li>Without signal function: All inputs on the female connector set ("high" state).</li> <li>2-channel evaluation: 2-channel evaluation signal TRUE ("high" state)</li> </ul>
	green	flashing	<ul style="list-style-type: none"> <li>Without signal function: Only one input on the female connector set ("high" state).</li> <li>2-channel evaluation: -</li> </ul>
		red	on

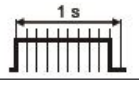
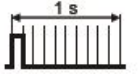
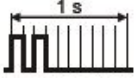
LED indicator	Color	Status	Description
			Error detected in 2-channel evaluation.
		flashing	<ul style="list-style-type: none"> <li>Without signal function: Error detected on only 1 input of the female connector, the signal is NOT set on the second input ("low" state).</li> <li>2-channel evaluation: -</li> </ul>
	red / green	flashing	<ul style="list-style-type: none"> <li>Without signal function: Error detected on only 1 input of the female connector, the signal is set on the second input ("high" state).</li> <li>2-channel evaluation: -</li> </ul>

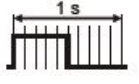
LED indicator	Color	Status	Description
<b>S E</b>	off		RUN state or 24 Vdc supply not present
	red		boot phase or missing TM5 link or non-functioning processor (refer to safety message below)
			pre-operational state
			communication channel is not OK
			firmware for this module is a non-certified pilot version <b>NOTE:</b> If you observe this indication, you must immediately replace the module, or update its firmware with a certified version. In all cases, contact your Schneider Electric representative.
			boot phase, inoperable firmware
	on		Safety-related status is active.

Whenever the **S** and **E** LED indicators are illuminated continuously, this indicates that the module is inoperative. There is also a diagnostic available in the Safety Logic Controller to indicate this state. Replacement of the module must be made immediately. It is your responsibility to ensure all necessary repairs are made promptly to enable proper functionality.

<b>⚠ WARNING</b>
<p><b>LOSS OF SAFETY FUNCTION</b></p> <ul style="list-style-type: none"> <li>Immediately replace any and all modules that indicate that they are in an inoperable state.</li> <li>Ensure that the effect on un-repaired equipment is taken into account in your risk assessment.</li> <li>Make all necessary repairs to equipment before re-starting, or continuing service of, your machine.</li> </ul> <p><b>Failure to follow these instructions can result in death, serious injury, or equipment damage.</b></p>

# TM7SDI8DFS Characteristics

## Introduction

This section describes the characteristics of the TM7SDI8DFS module. See also Environmental Characteristics (see PacDrive TM5 / TM7 Safety Flexible System, System Planning and Installation Guide).

<b>⚠ DANGER</b>	
<b>FIRE HAZARD</b>	
Use only the correct wire sizes for the maximum current capacity of the I/O channels and power supplies.	
<b>Failure to follow these instructions will result in death or serious injury.</b>	

<b>⚠ WARNING</b>	
<b>UNINTENDED EQUIPMENT OPERATION</b>	
Do not exceed any of the rated values specified in the environmental and electrical characteristics tables.	
<b>Failure to follow these instructions can result in death, serious injury, or equipment damage.</b>	

## General Characteristics

The following table lists the general characteristics of the TM7SDI8DFS digital input module:

General characteristics		
Rated power supply voltage		24 Vdc
Status indicators		<ul style="list-style-type: none"> <li>I/O functions per channel</li> <li>operating state</li> <li>module status</li> </ul>
Diagnostics	module run and detected error	indicated by status LED indicator and software status
	inputs / outputs	indicated by status LED indicator and software status
Electrical isolation <sup>1)</sup>	channel - bus	See note.
	channel - channel	no galvanic isolation
TM5 Bus 5 Vdc current draw		150 mA
24 Vdc I/O segment current draw		87.5 mA
Connection type	inputs / outputs	M12, 8-pin, or M12, 5-pin, A-coded
	module supply	M8, 4-pin
	TM5 link	M12, B-coded
Certifications and standards		<ul style="list-style-type: none"> <li>CE</li> <li>cULus</li> <li>KC</li> <li>EN IEC 61508:2010</li> <li>EN IEC 62061:2010</li> <li>EN ISO 13849-1:2008</li> <li>EN IEC 61511:2004</li> <li>EN 50156-1:2004</li> </ul>
Maximum internal cycle time		1 ms

General characteristics	
Minimum cycle time	200 µs
Minimum I/O update time	500 µs
Minimum safety-related response time	6 ms
Id code for firmware update	47996 dec

**NOTE** <sup>(1)</sup> The isolation of the electronic module is 500 Vac RMS between the electronics power by the TM5 to TM7 bus and those powered by 24 Vdc I/O power segment connected to the module. In practice, the electronic module is installed in the bus base, and there is a bridge between the TM5 power bus and the 24 Vdc I/O power segment. The two power circuits reference the same functional ground (FE) through specific components designed to reduce effects of electromagnetic interference. These components are rated at 30 Vdc or 60 Vdc. This effectively reduces isolation of the entire system from the 500 Vac RMS.

## Operating Conditions

The following table lists the operating conditions for the TM7SDI8DFS module:

Operating conditions		
Mounting orientation	horizontal or vertical	
Operating temperature	0...60 °C (+32...140 °F)	
Relative humidity	5...95%	
Installation at altitudes above sea level:	0...2000 m (0...6561 ft)	no derating for altitude
	> 2000 m (>6561 ft)	reduction of ambient temperature by 0.5 °C per 100 m (0.9 °F per 328 ft)
EN 60529 protection	IP67	

## Storage and Transport Conditions

The following table lists the storage and transport conditions for the TM7SDI8DFS module:

Storage and transport conditions	
Temperature	-25...+85 °C (-13...+185 °F)
Relative humidity	5...95%

## Mechanical Characteristics

The following table lists the mechanical characteristics for the TM7SDI8DFS module:

Mechanical characteristics		
Dimensions (W x H x D)	53 x 85 x 42 mm (2.086 x 3.35 x 1.65 in.)	
Weight	190 g (6.70 oz.)	
Torque for connections	M8	Maximum 0.4 Nm (0.29 lbf ft)
	M12	Maximum 0.6 Nm (0.44 lbf ft)

## Module Supply Characteristics

The following table lists the module supply characteristics for the TM7SDI8DFS module



Module supply characteristics	
Integrated protection	reverse polarity protection
Rated voltage	24 Vdc
Voltage range	18...30 Vdc

### Non-Safety-Related Digital Input Characteristics

The following table lists the non-safety-related digital input characteristics of the TM7SDI8DFS module:

Digital input		
Number of input channels		2 (without safety functionality)
Rated voltage		24 Vdc
Input filter	hardware	≤ 150 μs
Input circuit		sink
Input voltage		20.4...28.8 Vdc
Input current at 24 Vdc		typical: 6 mA
Input resistance		typical: 4 kΩ
Switching threshold	low	<5 Vdc
	high	>15 Vdc
Isolation voltage between channel and bus		See note.

**NOTE** <sup>(1)</sup> The isolation of the electronic module is 500 Vac RMS between the electronics power by the TM5 to TM7 bus and those powered by 24 Vdc I/O power segment connected to the module. In practice, the electronic module is installed in the bus base, and there is a bridge between the TM5 power bus and the 24 Vdc I/O power segment. The two power circuits reference the same functional ground (FE) through specific components designed to reduce effects of electromagnetic interference. These components are rated at 30 Vdc or 60 Vdc. This effectively reduces isolation of the entire system from the 500 Vac RMS.

### Safety-Related Digital Inputs Characteristics

The following table lists the safety-related digital input characteristics of the TM7SDI8DFS module:

Digital input		
Number of input channels		8 safety-related inputs
Rated voltage		24 Vdc
Input filter	hardware	≤ 150 μs
	software	configuration 0...500 ms
Input circuit		sink
Input voltage		20.4...28.8 Vdc
Input current at 24 Vdc		typical: 6.3 mA
Input resistance		typical: 3.87 kΩ
Switching threshold	low	<5 Vdc
	high	>15 Vdc
Isolation voltage between channel and bus <sup>1)</sup>		See note.
Error detection time		200 ms

**NOTE** <sup>(1)</sup> The isolation of the electronic module is 500 Vac RMS between the electronics power by the TM5 to TM7 bus and those powered by 24 Vdc I/O power segment connected to the module. In practice, the electronic module is installed in the bus base, and there is a bridge between the TM5 power bus and the 24 Vdc I/O power segment. The two power circuits reference the same functional ground (FE) through specific components designed to reduce effects of electromagnetic interference. These components are rated at 30 Vdc or 60 Vdc. This effectively reduces isolation of the entire system from the 500 Vac RMS.

## Non-Safety-Related Digital Output Characteristics

The following table lists the non-safety-related digital output characteristics of the TM7SDI8DFS module:

Digital outputs	
Number of output channels	2 (without safety functionality)
Rated voltage	24 Vdc
Rated output current	0.6 A
Total current	1.2 A
Output protection	<ul style="list-style-type: none"> <li>• disable individual channels for over-current or short circuit</li> <li>• integrated protection of switching inductances</li> </ul>
Design	<ul style="list-style-type: none"> <li>• FET, positive switching</li> <li>• output level can be read</li> </ul>
Switching voltage	modules supply minus residual voltage
Diagnostics status	Output monitoring
Leakage current when switched off	< 500 $\mu$ A
Residual voltage	$\leq$ 300 mVdc at rated voltage
Short circuit peak current	< 12.0 A
Peak output current	1.0 A
Braking voltage when switching off inductive loads	typical: 50 Vdc
Maximum capacitive load	100 nF
Isolation voltage between channel and bus <sup>1)</sup>	See note.

**NOTE** <sup>(1)</sup> The isolation of the electronic module is 500 Vac RMS between the electronics power by the TM5 to TM7 bus and those powered by 24 Vdc I/O power segment connected to the module. In practice, the electronic module is installed in the bus base, and there is a bridge between the TM5 power bus and the 24 Vdc I/O power segment. The two power circuits reference the same functional ground (FE) through specific components designed to reduce effects of electromagnetic interference. These components are rated at 30 Vdc or 60 Vdc. This effectively reduces isolation of the entire system from the 500 Vac RMS.

## Digital Test (Pulse) Output Characteristics

The following table lists the digital test (pulse) output characteristics of the TM7SDI8DFS module:

Digital test outputs	
Rated voltage	24 Vdc
Design	Push-Pull
Switching voltage	equal to module supply minus residual voltage
Rated output current	40 mA

Digital test outputs	
Total current	80 mA
Output protection	disable individual channels if short-circuit of supply occurs
Short circuit peak current	100 mA
Diagnostics status	Output monitoring
Residual voltage	typical: 2 Vdc
Maximum cable length	50 m / 164 ft (shielded)

### Safety-Related Characteristics

The following table lists the safety-related characteristics of the TM7SDI8DFS module:

Criteria	Characteristics
	<b>Safety-related digital input</b>
Maximum performance level according to EN ISO 13849-1:2008	PL e
Category according to EN ISO 13849-1:2008	<ul style="list-style-type: none"> <li>CAT 3 when using individual input channels</li> <li>CAT 4 when using input channel pairs (for example S11 &amp; S12) or more</li> </ul>
Maximum safety integrity level according to EN IEC 62061:2010	SIL 3
Maximum safety integrity level according to EN IEC 61508:2010	SIL 3
Maximum safety integrity level according to EN IEC 61511:2004	SIL 3
PFH	$< 1 \cdot 10^{-10}$
PFD	<ul style="list-style-type: none"> <li><math>&lt; 1 \cdot 10^{-5}</math> at a proof test interval of 10 years</li> <li><math>&lt; 2 \cdot 10^{-5}</math> at a proof test interval of 20 years</li> </ul>
PT	Maximum 20 years
DC	>94%
SFF	>90%
MTTFd	2500 years
Life time, page 26	20 years

## TM7SDI8DFS Wiring

### Connection Elements

The following figure presents the connection elements for the TM7SDI8DFS:

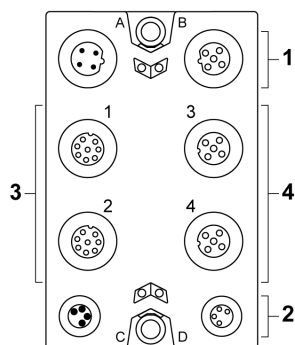

Number	Meaning
1	<ul style="list-style-type: none"> <li>• TM5 link</li> <li>• 2 x M12 (4-pin)</li> <li>• connector A: input</li> <li>• connector B: output</li> </ul>
2	<ul style="list-style-type: none"> <li>• Module supply 24 Vdc</li> <li>• 2 x M8 (4-pin)</li> <li>• connector C: supply feed</li> <li>• connector D: routing</li> </ul>
3	Connectors 1 and 2: <ul style="list-style-type: none"> <li>• Digital I/O: 2 x M12 (8-pin)</li> </ul>
4	Connectors 3 and 4: <ul style="list-style-type: none"> <li>• Digital I/O: 2 x M12 (5-pin)</li> </ul>

## Pin Assignments

The pin assignments of the power and communication connectors (A, B, C and D) are provided in the TM7 Physical Description, page 36.

Pin assignment for the 8-pin I/O connectors 1 and 2 of the TM7SDI8DFS module:

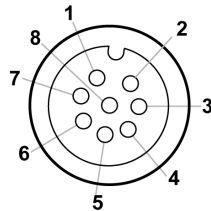

1 +24 Vdc

2 Test (pulse) output 1

3 COM

4 SI x (safety-related inputs)

5 DI x

6 Test (pulse) output 2

7 SI x (safety-related inputs)

8 DO x (non-safety-related outputs)

Connector socket	Pin1	Pin2	Pin3	Pin4	Pin5	Pin6	Pin7	Pin8
1 (IN/OUT)	+24 Vdc	Test (pulse) output 1	COM	SI 1	DI 1	Test (pulse) output 2	SI 2	DO 1
2 (IN/OUT)	+24 Vdc	Test (pulse) output 1	COM	SI 3	DI 2	Test (pulse) output 2	SI 4	DO 2

**NOTE:** Test (pulse) output 1 and test (pulse) 2 are shared between the connector sockets 1, 2, 3 and 4.

Pin assignment for the 5-pin I/O connectors 3 and 4 of the TM7SDI8DFS module:

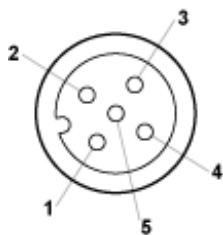

- 1 Test (pulse) x
- 2 SI x (safety-related inputs)
- 3 COM
- 4 SI x (safety-related inputs)
- 5 Test (pulse) x (inputs)

Connector socket	Pin1	Pin2	Pin3	Pin4	Pin5
3 (IN)	Test (pulse) 1	SI 5	COM	SI 6	Test (pulse) 2
4 (IN)	Test (pulse) 1	SI 7	COM	SI 8	Test (pulse) 2

**NOTE:** Test (pulse) output 1 and test (pulse) 2 are shared between the connector sockets 1, 2, 3 and 4.

**NOTE:** Cross-circuits between the two channels of a connector cannot be ruled out according to ISO 13849-1. This is why shared error handling, page 42 is implemented for both channels of a connector. This means that both channels are switched off as soon as an error has been detected on one channel.

Detected errors are acknowledged in a similar way. As soon as a detected channel error has been acknowledged, the error state on the other channel of the same connector is also acknowledged.

However, the restart inhibit is separately active for each channel to help prevent unintentional enabling of a channel.

⚠ WARNING
<p><b>IP67 NON-CONFORMANCE</b></p> <ul style="list-style-type: none"> <li>Properly fit all connectors with cables or sealing plugs and tighten for IP67 conformance according to the torque values as specified in this document.</li> <li>Do not connect or disconnect cables or sealing plugs in the presence of water or moisture.</li> </ul> <p><b>Failure to follow these instructions can result in death, serious injury, or equipment damage.</b></p>

# TM5 Safety Digital Output Modules

## What's in This Part

TM5SDO2TFS Safety Module 2DO 24 Vdc .....	103
TM5SDO2TAFS Safety Module 2DO 24 Vdc .....	110
TM5SDO2DTRFS Safety Module 2DO 230 Vac/6 A, 24 Vdc/6 A .....	118
TM5SDO4TFS Safety Module 4DO 24 Vdc .....	126
TM5SDO4TAFS Safety Module 4DO 24 Vdc .....	134
TM5SDO6TBFS Safety Module 6DO 24 Vdc .....	142

# TM5SDO2TFS Safety Module 2DO 24 Vdc

## What's in This Chapter

TM5SDO2TFS Presentation ..... 103  
 TM5SDO2TFS Characteristics ..... 106  
 TM5SDO2TFS Wiring..... 109

## TM5SDO2TFS Presentation

### Main Features

The following table describes the main features of the Safety Digital Output module TM5SDO2TFS:

Main Features	
Number of Outputs	2
Output Type	safety-related digital FET outputs with current monitoring
Protective Features	open-circuit detection
	integrated over-current protection and inductive load resistance
Rated Output Current	0.5 A
Rated Voltage	24 Vdc

 **DANGER**

**POTENTIAL FOR EXPLOSION**

- Only use this equipment in non-hazardous locations or in locations that comply with Class I, Division 2, Groups A, B, C and D.
- Do not substitute components which would impair compliance to Class I, Division 2.
- Do not connect or disconnect equipment unless power has been removed or the location is known to be non-hazardous.

**Failure to follow these instructions will result in death or serious injury.**

## Ordering Information

The following figure presents the module in combination with the required components:

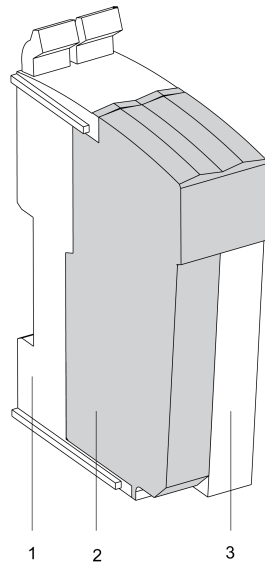

The following table presents the reference of the module:

Number	Model Number	Description	Color
2	TM5SDO2TFS	TM5 Safety Digital Output module	red

The following table presents the references for the required components:

Number	Reference	Description	Color
1	TM5ACBM3-FS	TM5 Safety bus base, safety coded, internal I/O supply is interconnected	red
3	TM5ACTB52-FS	TM5 Safety terminal block, 12-pin, safety coded	red

**NOTE:** A TM5 Safety bus base and a TM5 Safety terminal block are required for operation of the module, and are sold separately. For more information, refer to TM5ACBM3FS Safety bus base, page 232 and TM5ACTB52FS Safety terminal block, page 238.

## Status LED Indicators

This figure presents the TM5SDO2TFS status LED indicators:

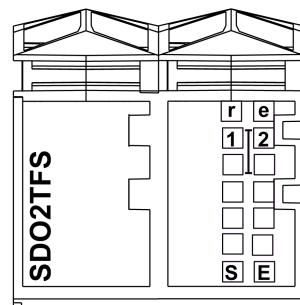



The following tables describe the status LED indicators:

LED indicator	Color	Status	Description
r	off		Module supply not connected.
	green	single flash	reset mode

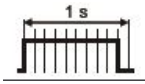
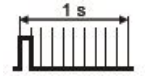

LED indicator	Color	Status	Description
		double flash	firmware update in progress
		flashing	pre-operational state
		on	RUN state
e	off		No error detected or module supply not connected.
	red	flashing	boot loader mode
		triple flash	firmware update in progress
		on	error detected
r+e	steady red/single green flash	invalid configuration	

LED indicator	Color	Status	Description
1 2	red	on	Indicates either an error has been detected for the corresponding output or that the safety-related output is being used as a non-safety-related output. <b>NOTE:</b> During the start-up phase, the channel LED indicators are steady red.
	orange	on	output set

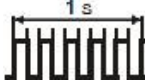
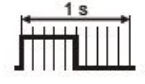
LED indicator	Color	Status	Description
S E	off		RUN state or 24 Vdc supply not present
	red		boot phase or missing TM5 link or non-functioning processor (refer to safety message below)
			pre-operational state
			communication channel is not OK
			firmware for this module is a non-certified pilot version <b>NOTE:</b> If you observe this indication, you must immediately replace the module, or update its firmware with a certified version. In all cases, contact your Schneider Electric representative.
			boot phase, inoperable firmware
	on		Safety-related status is active.

Whenever the **S** and **E** LED indicators are illuminated continuously, this indicates that the module is inoperative. There is also a diagnostic available in the Safety Logic Controller to indicate this state. Replacement of the module must be made immediately. It is your responsibility to ensure all necessary repairs are made promptly to enable proper functionality.

<b>⚠ WARNING</b>
<p><b>LOSS OF SAFETY FUNCTION</b></p> <ul style="list-style-type: none"> <li>• Immediately replace any and all modules that indicate that they are in an inoperable state.</li> <li>• Ensure that the effect on un-repaired equipment is taken into account in your risk assessment.</li> <li>• Make all necessary repairs to equipment before re-starting, or continuing service of, your machine.</li> </ul> <p><b>Failure to follow these instructions can result in death, serious injury, or equipment damage.</b></p>

## TM5SDO2TFS Characteristics

### Introduction

This section describes the characteristics of the TM5SDO2TFS module. See also TM5 Environmental Characteristics, page 26.

<b>⚠ DANGER</b>
<p><b>FIRE HAZARD</b></p> <p>Use only the correct wire sizes for the maximum current capacity of the I/O channels and power supplies.</p> <p><b>Failure to follow these instructions will result in death or serious injury.</b></p>

<b>⚠ WARNING</b>
<p><b>UNINTENDED EQUIPMENT OPERATION</b></p> <p>Do not exceed any of the rated values specified in the environmental and electrical characteristics tables.</p> <p><b>Failure to follow these instructions can result in death, serious injury, or equipment damage.</b></p>

### General Characteristics

The following table lists the general characteristics of the TM5SDO2TFS module:

General Characteristics		
Rated power supply voltage		24 Vdc
Status indicators		<ul style="list-style-type: none"> <li>• I/O functions per channel</li> <li>• operating state</li> <li>• module status</li> </ul>
Diagnostics		Module run and detected error conditions indicated by status LED indicator and software status.
Electrical isolation <sup>1)</sup>	channel - bus	See note.
	channel - channel	no galvanic isolation
TM5 Bus 5 Vdc current draw		50 mA
24 Vdc I/O segment current draw		40.8 mA
Certifications and standards		<ul style="list-style-type: none"> <li>• CE</li> <li>• UL508 (ULus)</li> <li>• IEC 61508</li> </ul>

General Characteristics	
	<ul style="list-style-type: none"> <li>• IEC 62061</li> <li>• EN 13849</li> </ul>
Maximum internal cycle time	800 µs
Minimum cycle time	200 µs
Minimum I/O update time	400 µs
Id code for firmware update	7958 dec

**NOTE** <sup>(1)</sup> The isolation of the electronic module is 500 Vac RMS between the electronics power by the TM5 bus and those powered by 24 Vdc I/O power segment connected to the module. In practice, the electronic module is installed in the bus base, and there is a bridge between the TM5 power bus and the 24 Vdc I/O power segment. The two power circuits reference the same functional ground (FE) through specific components designed to reduce effects of electromagnetic interference. These components are rated at 30 Vdc or 60 Vdc. This effectively reduces isolation of the entire system from the 500 Vac RMS.

### Operating Conditions

The following table lists the operating conditions for the TM5SDO2TFS module:

Operating Conditions		
Mounting orientation	horizontal or vertical	
Operating temperature	horizontal installation	0...+55 °C (+32...131 °F), possibility of derating bonus, see note.
	vertical installation	0...+42.5 °C (+32...108.5 °F)
Relative humidity	5...95%	
Installation at altitudes above sea level:	0 up to 2000 m (0 up to 6561 ft)	no derating for altitude
	> 2000 m (>6561 ft)	reduction of ambient temperature by 0.5 °C per 100 m (0.9 °F per 328 ft)
EN 60529 Protection type	IP20	

**NOTE:** If a TM5SD000 is installed on the side of the module, the horizontal installation derating is shifted to the right by the following derating bonus:

- TM5SD000 to the left: +0 °C (+0 °F)
- TM5SD000 to the right: +2.5 °C (+4.5 °F)
- TM5SD000 to the left and right: +2.5 °C (+4.5 °F)

### Storage and Transport Conditions

The following table lists the storage and transport conditions for the TM5SDO2TFS module:

Storage and Transport Conditions	
Temperature	-25...+70 °C (-13...+158 °F)
Relative humidity	5...95%

### Digital Output Characteristics

The following table lists the digital output characteristics of the TM5SDO2TFS module:

Digital Output	
Number of output channels	2
Rated voltage	24 Vdc
Rated output current	0.5 A
Total current	1.0 A
Output protection	<ul style="list-style-type: none"> <li>disable the channel in case of over-current or short circuit,</li> <li>inductive load resistance</li> </ul>
Design	<ul style="list-style-type: none"> <li>FET, 1x n switching, 1x p switching, type A</li> <li>Output level can be read</li> <li>Open-circuit detection</li> </ul>
Switching voltage	24 Vdc (-15% / +20%)
Diagnostics status	Output monitoring with configurable delay
Leakage current when switched off	<10 µA
Residual voltage	< 120 mV at 0.5 A rated current without OSSD
Short circuit peak current	< 12 A
Test pulse length	Maximum 500 µs
Time between two test pulses	Minimum 49.5 ms
Re-arming after overload or short circuit detection	Set <code>ReleaseOutput0x</code> from 0 to 1. Then, after a positive edge on the <code>SafeDigitalOutput0x</code> channel, the output goes high.
Braking voltage when switching off inductive loads	typical: 40 Vdc
Maximum capacitive load	100 nF
Isolation voltage between channel and bus <sup>1)</sup>	See note.
Open circuit detection	Via internal current measurement <ul style="list-style-type: none"> <li>output current &lt;10 mA: Signal CurrentOK = FALSE</li> <li>output current &gt;50 mA: Signal CurrentOK = TRUE</li> </ul>
Error detection time	1 s

**NOTE** <sup>(1)</sup> The isolation of the electronic module is 500 Vac RMS between the electronics power by the TM5 bus and those powered by 24 Vdc I/O power segment connected to the module. In practice, the electronic module is installed in the bus base, and there is a bridge between the TM5 power bus and the 24 Vdc I/O power segment. The two power circuits reference the same functional ground (FE) through specific components designed to reduce effects of electromagnetic interference. These components are rated at 30 Vdc or 60 Vdc. This effectively reduces isolation of the entire system from the 500 Vac RMS.

## Safety-Related Characteristics

The following table lists the safety-related characteristics of the TM5SDO2TFS module:

Criteria	Characteristic Value in DisableOSSD = No	Characteristic Value in DisableOSSD = Yes
Maximum performance level according to EN ISO 13849	PL e	PL d
Category according to EN ISO 13849	CAT 4	CAT 3
Maximum safety integrity level according to IEC 62061	SIL 3	SIL 2

Criteria	Characteristic Value in DisableOSSD = No	Characteristic Value in DisableOSSD = Yes
Maximum safety integrity level according to IEC 61508	SIL 3	SIL 2
PFH	<math>1 \cdot 10^{-10}</math>	
PFD	<ul style="list-style-type: none"> <li>&lt;math&gt;1 \cdot 10^{-5}&lt;/math&gt; at a proof test interval of 10 years</li> <li>&lt;math&gt;2 \cdot 10^{-5}&lt;/math&gt; at a proof test interval of 20 years</li> </ul>	
PT	Maximum 20 years	
DC	>94%	>60%
SFF	>90%	>60%
MTTFd	2500 years	
Life time, page 26	20 years	

## TM5SDO2TFS Wiring

### Pin Assignments / Connection Example

The following figure presents a connection example for the TM5SDO2TFS:

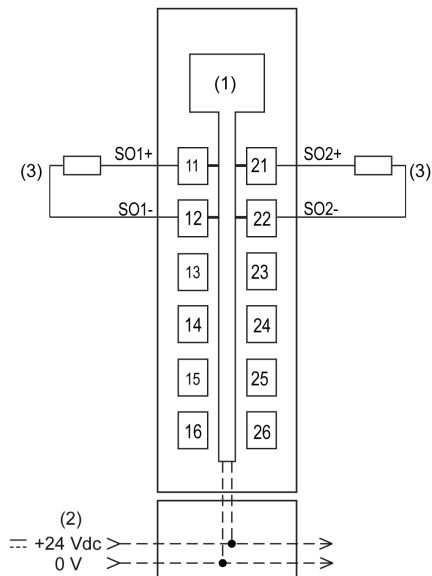

- 1 Internal electronics
- 2 24 Vdc I/O power segment integrated into the bus bases
- 3 Actuator 24 Vdc

**⚠ WARNING**

**UNINTENDED EQUIPMENT OPERATION**

Do not connect wires to unused terminals and/or terminals indicated as “No Connection (N.C.)”.

**Failure to follow these instructions can result in death, serious injury, or equipment damage.**

# TM5SDO2TAFS Safety Module 2DO 24 Vdc

## What's in This Chapter

TM5SDO2TAFS Presentation ..... 110  
 TM5SDO2TAFS Characteristics ..... 113  
 TM5SDO2TAFS Wiring ..... 117

## TM5SDO2TAFS Presentation

### Main Features

The following table describes the main features of the Safety Digital Output module TM5SDO2TAFS:

Main Features	
Number of Outputs	2
Output Type	safety-related digital FET outputs with current monitoring
Protective Features	open-circuit detection
	integrated over-current protection and inductive load resistance
Rated Output Current	2.0 A
Rated Voltage	24 Vdc

## ⚠ DANGER

### POTENTIAL FOR EXPLOSION

- Only use this equipment in non-hazardous locations or in locations that comply with Class I, Division 2, Groups A, B, C and D.
- Do not substitute components which would impair compliance to Class I, Division 2.
- Do not connect or disconnect equipment unless power has been removed or the location is known to be non-hazardous.

**Failure to follow these instructions will result in death or serious injury.**

## Ordering Information

The following figure presents the module in combination with the required components:

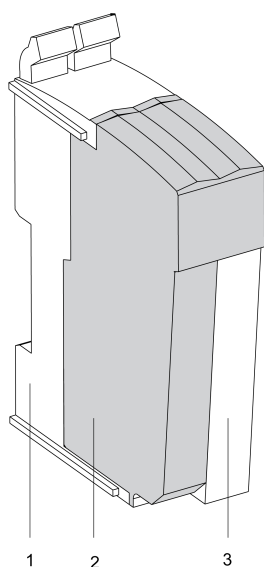

The following table presents the reference of the module:

Number	Model Number	Description	Color
2	TM5SDO2TAFS	TM5 Safety Digital Output module	red

The following table presents the references for the required components:

Number	Reference	Description	Color
1	TM5ACBM3-FS	TM5 Safety bus base, safety coded, internal I/O supply is interconnected	red
3	TM5ACTB52-FS	TM5 Safety terminal block, 12-pin, safety coded	red

**NOTE:** A TM5 Safety bus base and a TM5 Safety terminal block are required for operation of the module, and are sold separately. For more information, refer to TM5ACBM3FS Safety bus base, page 232 and TM5ACTB52FS Safety terminal block, page 238.

## Status LED Indicators

This figure presents the TM5SDO2TAFS status LED indicators:

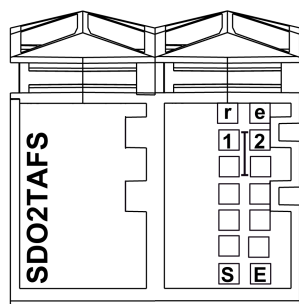

The following tables describe the status LED indicators:

LED indicator	Color	Status	Description
r	off		Module supply not connected.
	green	single flash	reset mode

LED indicator	Color	Status	Description
		double flash	firmware update in progress
		flashing	pre-operational state
		on	RUN state
e	off		No error detected or module supply not connected.
	red	flashing	boot loader mode
		triple flash	firmware update in progress
		on	error detected
r+e	steady red/single green flash	invalid configuration	

LED indicator	Color	Status	Description
1 2	red	on	Indicates either an error has been detected for the corresponding output or that the safety-related output is being used as a non-safety-related output.  <b>NOTE:</b> During the start-up phase, the channel LED indicators are steady red.
	orange	on	output set

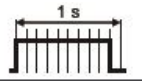
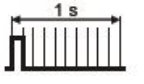
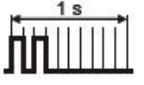
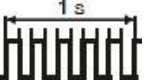
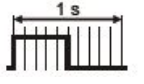
LED indicator	Color	Status	Description
S E	off		RUN state or 24 Vdc supply not present
	red		boot phase or missing TM5 link or non-functioning processor (refer to safety message below)
			pre-operational state
			communication channel is not OK
			firmware for this module is a non-certified pilot version  <b>NOTE:</b> If you observe this indication, you must immediately replace the module, or update its firmware with a certified version. In all cases, contact your Schneider Electric representative.
			boot phase, inoperable firmware
	on		Safety-related status is active.

Whenever the **S** and **E** LED indicators are illuminated continuously, this indicates that the module is inoperative. There is also a diagnostic available in the Safety Logic Controller to indicate this state. Replacement of the module must be made immediately. It is your responsibility to ensure all necessary repairs are made promptly to enable proper functionality.



<b>⚠ WARNING</b>
<p><b>LOSS OF SAFETY FUNCTION</b></p> <ul style="list-style-type: none"> <li>• Immediately replace any and all modules that indicate that they are in an inoperable state.</li> <li>• Ensure that the effect on un-repaired equipment is taken into account in your risk assessment.</li> <li>• Make all necessary repairs to equipment before re-starting, or continuing service of, your machine.</li> </ul> <p><b>Failure to follow these instructions can result in death, serious injury, or equipment damage.</b></p>

## TM5SDO2TAFS Characteristics

### Introduction

This section describes the characteristics of the TM5SDO2TAFS module. See also TM5 Environmental Characteristics, page 26.

<b>⚠ DANGER</b>
<p><b>FIRE HAZARD</b></p> <p>Use only the correct wire sizes for the maximum current capacity of the I/O channels and power supplies.</p> <p><b>Failure to follow these instructions will result in death or serious injury.</b></p>

<b>⚠ WARNING</b>
<p><b>UNINTENDED EQUIPMENT OPERATION</b></p> <p>Do not exceed any of the rated values specified in the environmental and electrical characteristics tables.</p> <p><b>Failure to follow these instructions can result in death, serious injury, or equipment damage.</b></p>

### General Characteristics

The following table lists the general characteristics of the TM5SDO2TAFS module:

General characteristics		
Rated power supply voltage		24 Vdc
Status indicators		<ul style="list-style-type: none"> <li>• I/O functions per channel</li> <li>• operating state</li> <li>• module status</li> </ul>
Diagnostics		Module run and detected error conditions indicated by status LED indicator and software status.
Electrical isolation <sup>1)</sup>	channel - bus	See note.
	channel - channel	no galvanic isolation
TM5 Bus 5 Vdc current draw		50 mA
24 Vdc I/O segment current draw		40.8 mA
Certifications and standards		<ul style="list-style-type: none"> <li>• CE</li> <li>• UL508 (ULus)</li> <li>• IEC 61508</li> </ul>

General characteristics	
	<ul style="list-style-type: none"> <li>• IEC 62061</li> <li>• EN 13849</li> </ul>
Maximum internal cycle time	800 µs
Minimum cycle time	200 µs
Minimum I/O update time	400 µs
Id code for firmware update	8201 dec

**NOTE** <sup>(1)</sup> The isolation of the electronic module is 500 Vac RMS between the electronics power by the TM5 bus and those powered by 24 Vdc I/O power segment connected to the module. In practice, the electronic module is installed in the bus base, and there is a bridge between the TM5 power bus and the 24 Vdc I/O power segment. The two power circuits reference the same functional ground (FE) through specific components designed to reduce effects of electromagnetic interference. These components are rated at 30 Vdc or 60 Vdc. This effectively reduces isolation of the entire system from the 500 Vac RMS.

## Operating Conditions

The following table lists the operating conditions for the TM5SDO2TAFS module:

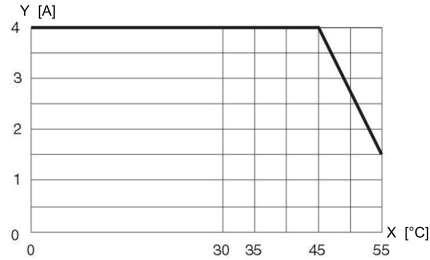
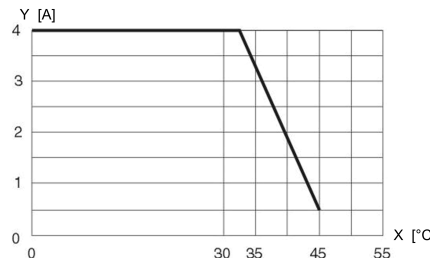
Operating Conditions		
Mounting orientation	horizontal or vertical	
Operating temperature	horizontal installation	0...+55 °C (+32...131 °F)  Derating - horizontal   <b>x-axis:</b> Ambient temperature [°C] <b>y-axis:</b> Output current [A]  <b>NOTE:</b> If a TM5SD000 is installed on the side of the module, the horizontal installation derating is shifted to the right by the following derating bonus: <ul style="list-style-type: none"> <li>• TM5SD000 to the left: +0 °C (+0 °F)</li> <li>• TM5SD000 to the right: +2.5 °C (+4.5 °F)</li> <li>• TM5SD000 to the left and right: +2.5 °C (+4.5 °F)</li> </ul>
	vertical installation	0...+45 °C (+32...113 °F)  Derating vertical   <b>x-axis:</b> Ambient temperature [°C] <b>y-axis:</b> Output current [A]

Operating Conditions		
		<b>NOTE:</b> Using a TM5SD000 does not provide a derating bonus in vertical installation.
Relative humidity		5...95%
Installation at altitudes above sea level:	0 up to 2000 m (0 up to 6561 ft)	no derating for altitude
	> 2000 m (>6561 ft)	reduction of ambient temperature by 0.5 °C per 100 m (0.9 °F per 328 ft)
EN 60529 Protection type		IP20

### Storage and Transport Conditions

The following table lists the storage and transport conditions for the TM5SDO2TAFS module:

Storage and Transport Conditions	
Temperature	-25...+70 °C (-13...+158 °F)
Relative humidity	5...95%

### Digital Output Characteristics

The following table lists the digital output characteristics of the TM5SDO2TAFS module:

Digital Output	
Number of output channels	2
Rated voltage	24 Vdc
Rated output current	2.0 A
Total current	4.0 A
Output protection	<ul style="list-style-type: none"> <li>disable the channel in case of over-current or short circuit</li> <li>inductive load resistance</li> </ul>
Design	<ul style="list-style-type: none"> <li>FET, 1x n switching, 1x p switching, type A</li> <li>Output level can be read</li> <li>Open-circuit detection</li> </ul>
Switching voltage	20.4...28.8 Vdc
Diagnostics status	Output monitoring with configurable delay
Leakage current when switched off	<10 µA
Residual voltage	< 480 mV at 2 A rated current without OSSD
Short circuit peak current	< 12 A
Test pulse length	Maximum 500 µs
Time between two test pulses	Minimum 49.5 ms
Re-arming after overload or short circuit detection	Set <code>ReleaseOutput0x</code> from 0 to 1. Then, after a positive edge on the <code>SafeDigitalOutput0x</code> channel, the output goes high.
Braking voltage when switching off inductive loads	typical: 40 Vdc
Maximum capacitive load	100 nF
Isolation voltage between channel and bus <sup>1)</sup>	See note.

Digital Output	
Open circuit detection	Via internal current measurement <ul style="list-style-type: none"> <li>• output current &lt;10 mA: Signal CurrentOK = FALSE</li> <li>• output current &gt;50 mA: Signal CurrentOK = TRUE</li> </ul>
Error detection time	1 s

**NOTE** (1) The isolation of the electronic module is 500 Vac RMS between the electronics power by the TM5 bus and those powered by 24 Vdc I/O power segment connected to the module. In practice, the electronic module is installed in the bus base, and there is a bridge between the TM5 power bus and the 24 Vdc I/O power segment. The two power circuits reference the same functional ground (FE) through specific components designed to reduce effects of electromagnetic interference. These components are rated at 30 Vdc or 60 Vdc. This effectively reduces isolation of the entire system from the 500 Vac RMS.

### Safety-Related Characteristics

The following table lists the safety-related characteristics of the TM5SDO2TAFS module:

Criteria	Characteristic Value in DisableOSSD = No	Characteristic Value in DisableOSSD = Yes
Maximum performance level according to EN ISO 13849	PL e	PL d
Category according to EN ISO 13849	CAT 4	CAT 3
Maximum safety integrity level according to IEC 62061	SIL 3	SIL 2
Maximum safety integrity level according to IEC 61508	SIL 3	SIL 2
PFH	<1*10 <sup>-10</sup>	
PFD	<ul style="list-style-type: none"> <li>• &lt;1*10<sup>-5</sup> at a proof test interval of 10 years</li> <li>• &lt;2*10<sup>-5</sup> at a proof test interval of 20 years</li> </ul>	
PT	Maximum 20 years	
DC	>94%	>60%
SFF	>90%	>60%
MTTFd	2500 years	
Life time, page 26	20 years	

# TM5SDO2TAFS Wiring

## Pin Assignments / Connection Example

The following figure presents a connection example for the TM5SDO2TAFS:

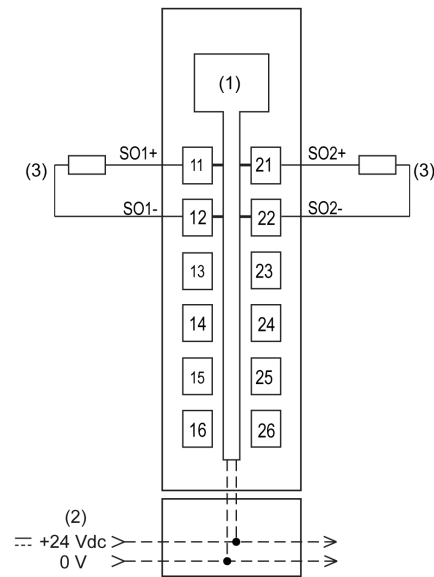

**1** Internal electronics

**2** 24 Vdc I/O power segment integrated into the bus bases

**3** Actuator 24 Vdc

### **▲ WARNING**

#### **UNINTENDED EQUIPMENT OPERATION**

Do not connect wires to unused terminals and/or terminals indicated as “No Connection (N.C.)”.

**Failure to follow these instructions can result in death, serious injury, or equipment damage.**

# TM5SDO2DTRFS Safety Module 2DO 230 Vac/6 A, 24 Vdc/6 A

## What's in This Chapter

TM5SDO2DTRFS Presentation..... 118  
 TM5SDO2DTRFS Characteristics ..... 120  
 TM5SDO2DTRFS Wiring ..... 125

## TM5SDO2DTRFS Presentation

### Main Features

The following table describes the main features of the Safety Relay Output module TM5SDO2DTRFS:

Main Features	
Number of outputs	2 relays
Output type	safety-related relay outputs, normally open contacts
Rated voltage	230 Vac/6 A, 24 Vdc/6 A

This equipment has been designed to operate outside of any hazardous location. Only install this equipment in zones known to be free of a hazardous atmosphere.

**⚠ DANGER**

**POTENTIAL FOR EXPLOSION**

Install and use this equipment in non-hazardous locations only.

**Failure to follow these instructions will result in death or serious injury.**

### Ordering Information

The following figure presents the module in combination with the required components:

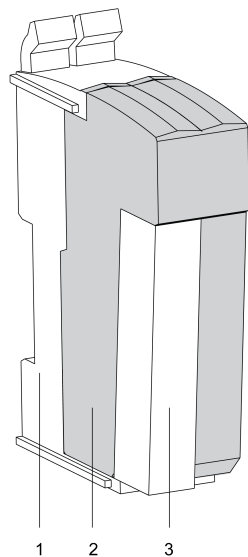

The following table presents the reference of the module:

Number	Reference	Description	Color
2	TM5SDO2DTRFS	TM5 Safety Relay Output module	red

The following table presents the references for the required components:

Number	Reference	Description	Color
1	TM5ACBM3-FS	TM5 Safety bus base, safety coded, internal I/O supply is interconnected	red
3	TM5ACTB52-FS	TM5 Safety terminal block, 12-pin, safety coded	red

**NOTE:** A TM5 Safety bus base and a TM5 Safety terminal block are required for operation of the module, and are sold separately. For more information, refer to TM5ACBM3FS Safety bus base, page 232 and TM5ACTB52FS Safety terminal block, page 238.

### Status LED Indicators

This figure presents the TM5SDO2DTRFS status LED indicators:

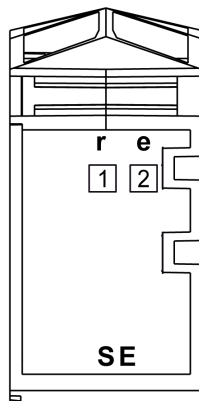

The following tables describe the status LED indicators:

LED indicator	Color	Status	Description
r	off		Module supply not connected.
	green	single flash	reset mode
		double flash	firmware update in progress
		flashing	pre-operational state
		on	RUN state
e	off		No error detected or module supply not connected.
	red	flashing	boot loader mode
		triple flash	firmware update in progress
		on	error detected
r+e	steady red/single green flash		invalid configuration

LED indicator	Color	Status	Description
1 2	red	on	Indicates either an error has been detected for the corresponding output or that the safety-related output is being used as a non-safety-related output. <b>NOTE:</b> When there is no connection to the Safety Logic Controller, all channels are steady red.
	orange	on	output set

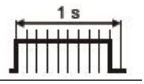
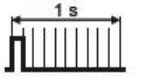
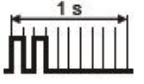
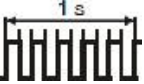
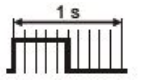
LED indicator	Color	Status	Description
S E	off		RUN state or 24 Vdc supply not present
	red		boot phase or missing TM5 link or non-functioning processor (refer to safety message below)
			pre-operational state
			communication channel is not OK
			firmware for this module is a non-certified pilot version <b>NOTE:</b> If you observe this indication, you must immediately replace the module, or update its firmware with a certified version. In all cases, contact your Schneider Electric representative.
			boot phase, inoperable firmware
	on		Safety-related status is active.

Whenever the **S** and **E** LED indicators are illuminated continuously, this indicates that the module is inoperable. There is also a diagnostic available in the Safety Logic Controller to indicate this state. Replacement of the module must be made immediately. It is your responsibility to ensure all necessary repairs are made promptly to enable proper functionality.

## ⚠ WARNING

### LOSS OF SAFETY FUNCTION

- Immediately replace any and all modules that indicate that they are in an inoperable state.
- Ensure that the effect on un-repaired equipment is taken into account in your risk assessment.
- Make all necessary repairs to equipment before re-starting, or continuing service of, your machine.

**Failure to follow these instructions can result in death, serious injury, or equipment damage.**

## TM5SDO2DTRFS Characteristics

### Introduction

This section describes the characteristics of the TM5SDO2DTRFS module. See also TM5 Environmental Characteristics, page 26.



**⚠ DANGER**

**FIRE HAZARD**

- Use only the correct wire sizes for the current capacity of the I/O channels and power supplies.
- For relay output (2 A) wiring, use conductors of at least 0.5 mm<sup>2</sup> (AWG 20) with a temperature rating of at least 80 °C (176 °F).
- For common conductors of relay output wiring (6 A), or relay output wiring greater than 2 A, use conductors of at least 1.0 mm<sup>2</sup> (AWG 16) with a temperature rating of at least 80 °C (176 °F).

**Failure to follow these instructions will result in death or serious injury.**

**⚠ WARNING**

**UNINTENDED EQUIPMENT OPERATION**

Do not exceed any of the rated values specified in the environmental and electrical characteristics tables.

**Failure to follow these instructions can result in death, serious injury, or equipment damage.**

## General Characteristics

The following table lists the general characteristics of the TM5SDO2DTRFS module:

General characteristics		
Rated power supply voltage		24 Vdc
Status indicators		<ul style="list-style-type: none"> <li>• I/O functions per channel</li> <li>• operating state</li> <li>• module status</li> </ul>
Diagnostics	module run and detected error	indicated by status LED indicator and software status
	inputs	indicated by status LED indicator
	outputs	indicated by status LED indicator and software status (detected output error status)
Electrical isolation <sup>1)</sup>	channel - bus	See note.
	channel - channel	See note.
TM5 Bus 5 Vdc current draw		52 mA
24 Vdc I/O segment current draw		47.9 mA
Certifications and standards		<ul style="list-style-type: none"> <li>• CE</li> <li>• cULus</li> <li>• EN IEC 61508:2010</li> <li>• EN IEC 62061:2010</li> <li>• EN ISO 13849-1:2008</li> <li>• EN IEC 61511:2004</li> <li>• EN 50156-1:2004</li> </ul> Relay: <ul style="list-style-type: none"> <li>• EN 50155</li> <li>• EN 50205</li> </ul>
Maximum internal cycle time		500 µs
Minimum cycle time		200 µs
Minimum I/O update time		500 µs
Id code for firmware update		53765 dec

**NOTE** <sup>(1)</sup> The isolation of the electronic module is 500 Vac RMS between the electronics power by the TM5 bus and those powered by 24 Vdc I/O power segment connected to the module. In practice, the electronic module is installed in the bus base, and there is a bridge between the TM5 power bus and the 24 Vdc I/O power segment. The two power circuits reference the same functional ground (FE) through specific components designed to reduce effects of electromagnetic interference. These components are rated at 30 Vdc or 60 Vdc. This effectively reduces isolation of the entire system from the 500 Vac RMS.

## Operating Conditions

The following table lists the operating conditions for the TM5SDO2DTRFS module:

Operating conditions		
Mounting orientation		horizontal or vertical
Operating temperature	horizontal installation	0...+55 °C (+32...131 °F), for derating refer to following table <sup>1</sup>
	vertical installation	0...+45 °C (+32...113 °F), for derating refer to following table <sup>1</sup>
Relative humidity		5...95%, non-condensing
Installation at altitudes above sea level:	0 up to 2000 m (0 up to 6561 ft)	no derating for altitude
	> 2000 m (>6561 ft)	reduction of ambient temperature by 0.5 °C per 100 m (0.9 °F per 328 ft)
EN 60529 Protection type		IP20

<sup>1</sup> Derating in relation to operating temperature and mounting orientation:

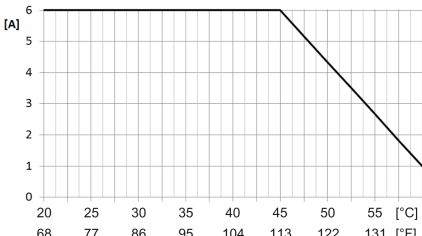
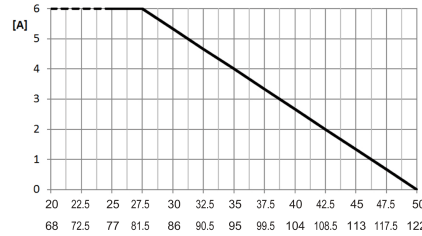
Horizontal installation, 0...+55 °C (+32...131 °F)	Vertical installation, 0...+45 °C (+32...113 °F)
 <p><b>X-axis:</b> Ambient temperature [°C/°F] <b>Y-axis:</b> Output current [A]</p>	 <p><b>X-axis:</b> Ambient temperature [°C/°F] <b>Y-axis:</b> Output current [A]</p>
<p><b>NOTE:</b> If a TM5SD000 is installed on the side of the module, the horizontal installation derating is shifted to the right by the following derating bonus:</p> <ul style="list-style-type: none"> <li>• TM5SD000 to the left: +0 °C (+0 °F)</li> <li>• TM5SD000 to the right: +2.5 °C (+4.5 °F)</li> <li>• TM5SD000 to the left and right: +2.5 °C (+4.5 °F)</li> </ul>	<p><b>NOTE:</b> Using a TM5SD000 does not provide a derating bonus in vertical installation.</p>

## Storage and Transport Conditions

The following table lists the storage and transport conditions for the TM5SDO2DTRFS module:

Storage and transport conditions	
Temperature	-25...+70 °C (-13...+158 °F)
Relative humidity	5...95%, non-condensing

## Relay Output Characteristics

The following table lists the relay output characteristics of the TM5SDO2DTRFS module:

Relay output		
Switching voltage range	5...24 Vdc, 5...230 Vac	
Switching current range	5...6000 mA	
Turn-around time on relay	maximum 50 ms	
Design	<ul style="list-style-type: none"> <li>1 normally open contact</li> <li>internal high-side and low-side control</li> </ul>	
Coil voltage	24 Vdc (-15% / +20%)	
Contact resistance (without terminal block)	typical: 20 mΩ	
Maximum switching capacity	AC1	230 Vac / 6 A
	AC15	230 Vac / 3 A
	DC1	24 Vdc / 6 A
	DC13	24 Vdc / 5 A / 0.1 Hz
Contact lifespan	<p><b>X-axis:</b> switching current (A)  <b>Y-axis:</b> switching cycle x 1000</p>	
Peak (inrush) current	30 A for 20 ms	
Overvoltage category in accordance with EN 60664-1	II	
The outputs must be protected against overload and short-circuit with an external fuse.	external 6 A gL/gG fuse (slow-blow fuse), LS circuit breaker C characteristic 1.6 A	
Isolation voltage between channel and bus <sup>1)</sup>	See note.	
Isolation voltage between channel and channel	230 Vac	

**NOTE** <sup>(1)</sup> The isolation of the electronic module is 300 Vac RMS between the electronics power by the TM5 bus and those powered by 24 Vdc I/O power segment connected to the module. In practice, the electronic module is installed in the bus base, and there is a bridge between the TM5 power bus and the 24 Vdc I/O power segment. The two power circuits reference the same functional ground (FE) through specific components designed to reduce effects of electromagnetic interference. These components are rated at 30 Vdc or 60 Vdc. This effectively reduces isolation of the entire system from the 300 Vac RMS.

## Safety-Related Characteristics

The following table lists the safety-related characteristics of the TM5SDO2DTRFS module:

Criteria	Characteristic value for relay channel
Maximum performance level according to EN ISO 13849-1:2008 PL	<ul style="list-style-type: none"> <li>• PL c if the relay channel is used independently</li> <li>• PL e if both relay channels are connected in series</li> </ul>
Category according to EN ISO 13849-1:2008	<ul style="list-style-type: none"> <li>• CAT 1 if the relay channel is used independently</li> <li>• CAT 4 if both relay channels are connected in series</li> </ul>
Maximum safety integrity level according to EN IEC 62061:2010	SIL 3 if both relay channels are connected in series
Maximum safety integrity level according to EN IEC 61508:2010	SIL 3 if both relay channels are connected in series
Maximum safety integrity level according to EN IEC 61511:2004	SIL 3 if both relay channels are connected in series
<ul style="list-style-type: none"> <li>• B10d at DC1</li> <li>• 6 A</li> <li>• 24 Vdc</li> </ul>	780,000 cycles
<ul style="list-style-type: none"> <li>• B10d at AC1</li> <li>• 6 A</li> <li>• 230 Vac</li> </ul>	780,000 cycles
<ul style="list-style-type: none"> <li>• B10d at AC15</li> <li>• 3 A</li> <li>• 230 Vac</li> </ul>	1,960,000 cycles
<ul style="list-style-type: none"> <li>• B10d at DC13</li> <li>• 5 A</li> <li>• 24 Vdc</li> </ul>	780,000 cycles
SFF	>90%
Life time, page 26	20 years

**NOTE:** The B10d values only apply when the relay is activated at least once a year.

## TM5SDO2DTRFS Wiring

### Pin Assignments / Connection Example

The following figure presents a connection example for the TM5SDO2DTRFS:

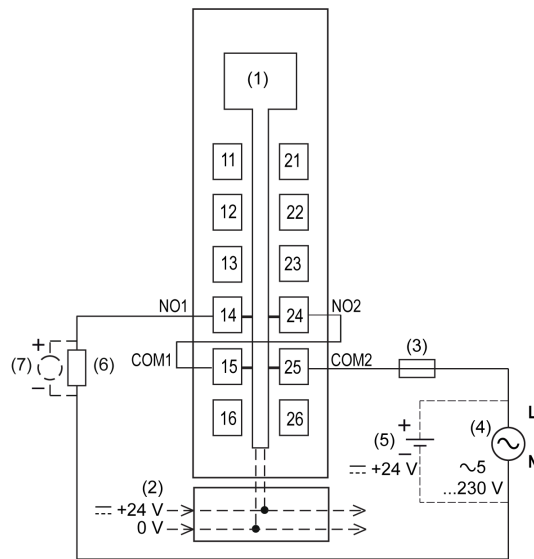

- 1 Internal electronics
- 2 24 Vdc I/O power segment integrated into the bus bases
- 3 External fuse sized to the load and its characteristics, maximum 6 A
- 4 External power supply, 5...230 Vac
- 5 External power supply, 24 Vdc
- 6 Actuator 2-wire load
- 7 Inductive load protection

### ▲ WARNING

#### UNINTENDED EQUIPMENT OPERATION

Do not connect wires to unused terminals and/or terminals indicated as "No Connection (N.C.)".

**Failure to follow these instructions can result in death, serious injury, or equipment damage.**

# TM5SDO4TFS Safety Module 4DO 24 Vdc

## What's in This Chapter

TM5SDO4TFS Presentation ..... 126  
 TM5SDO4TFS Characteristics ..... 129  
 TM5SDO4TFS Wiring..... 132

## TM5SDO4TFS Presentation

### Main Features

The following table describes the main features of the Safety Digital Output module TM5SDO4TFS:

Main Features	
Number of Outputs	4
Output Type	safety-related digital FET outputs with current monitoring
Protective Features	open-circuit detection
	integrated over-current protection and inductive load resistance
Rated Output Current	0.5 A
Rated Voltage	24 Vdc

## ⚠ DANGER

### POTENTIAL FOR EXPLOSION

- Only use this equipment in non-hazardous locations or in locations that comply with Class I, Division 2, Groups A, B, C and D.
- Do not substitute components which would impair compliance to Class I, Division 2.
- Do not connect or disconnect equipment unless power has been removed or the location is known to be non-hazardous.

**Failure to follow these instructions will result in death or serious injury.**

## Ordering Information

The following figure presents the module in combination with the required components:

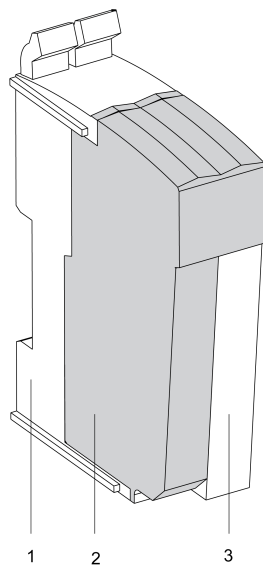

The following table presents the reference of the module:

Number	Model Number	Description	Color
2	TM5SDO4TFS	TM5 Safety Digital Output module	red

The following table presents the references for the required components:

Number	Reference	Description	Color
1	TM5ACBM3-FS	TM5 Safety bus base, safety coded, internal I/O supply is interconnected	red
3	TM5ACTB52-FS	TM5 Safety terminal block, 12-pin, safety coded	red

**NOTE:** A TM5 Safety bus base and a TM5 Safety terminal block are required for operation of the module, and are sold separately. For more information, refer to TM5ACBM3FS Safety bus base, page 232 and TM5ACTB52FS Safety terminal block, page 238.

## Status LED Indicators

This figure presents the TM5SDO4TFS status LED indicators:

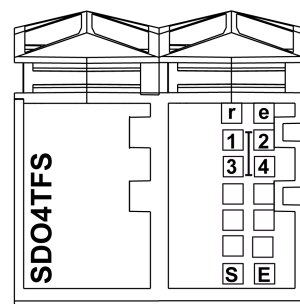

The following tables describe the status LED indicators:

LED indicator	Color	Status	Description
r	off		Module supply not connected.
	green	single flash	reset mode

LED indicator	Color	Status	Description
		double flash	firmware update in progress
		flashing	pre-operational state
		on	RUN state
e	off		No error detected or module supply not connected.
	red	flashing	boot loader mode
		triple flash	firmware update in progress
		on	error detected
r+e	steady red/single green flash	invalid configuration	

LED indicator	Color	Status	Description
1 2 3 4	red	on	Indicates either an error has been detected for the corresponding output or that the safety-related output is being used as a non-safety-related output.  <b>NOTE:</b> During the start-up phase, the channel LED indicators are steady red.
	orange	on	output set

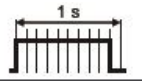
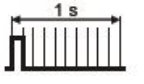
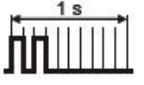
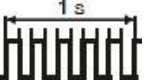
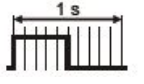
LED indicator	Color	Status	Description
S E	off		RUN state or 24 Vdc supply not present
	red		boot phase or missing TM5 link or non-functioning processor (refer to safety message below)
			pre-operational state
			communication channel is not OK
			firmware for this module is a non-certified pilot version  <b>NOTE:</b> If you observe this indication, you must immediately replace the module, or update its firmware with a certified version. In all cases, contact your Schneider Electric representative.
			boot phase, inoperable firmware
	on		Safety-related status is active.

Whenever the **S** and **E** LED indicators are illuminated continuously, this indicates that the module is inoperative. There is also a diagnostic available in the Safety Logic Controller to indicate this state. Replacement of the module must be made immediately. It is your responsibility to ensure all necessary repairs are made promptly to enable proper functionality.



<b>⚠ WARNING</b>
<p><b>LOSS OF SAFETY FUNCTION</b></p> <ul style="list-style-type: none"> <li>• Immediately replace any and all modules that indicate that they are in an inoperable state.</li> <li>• Ensure that the effect on un-repaired equipment is taken into account in your risk assessment.</li> <li>• Make all necessary repairs to equipment before re-starting, or continuing service of, your machine.</li> </ul> <p><b>Failure to follow these instructions can result in death, serious injury, or equipment damage.</b></p>

## TM5SDO4TFS Characteristics

### Introduction

This section describes the characteristics of the TM5SDO4TFS module. See also TM5 Environmental Characteristics, page 26.

<b>⚠ DANGER</b>
<p><b>FIRE HAZARD</b></p> <p>Use only the correct wire sizes for the maximum current capacity of the I/O channels and power supplies.</p> <p><b>Failure to follow these instructions will result in death or serious injury.</b></p>

<b>⚠ WARNING</b>
<p><b>UNINTENDED EQUIPMENT OPERATION</b></p> <p>Do not exceed any of the rated values specified in the environmental and electrical characteristics tables.</p> <p><b>Failure to follow these instructions can result in death, serious injury, or equipment damage.</b></p>

### General Characteristics

The following table lists the general characteristics of the TM5SDO4TFS module:

General Characteristics		
Rated power supply voltage	24 Vdc	
Status indicators	<ul style="list-style-type: none"> <li>• I/O functions per channel</li> <li>• operating state</li> <li>• module status</li> </ul>	
Diagnostics	Module run and detected error conditions indicated by status LED indicator and software status.	
Electrical isolation <sup>1)</sup>	channel - bus	See note.
	channel - channel	no galvanic isolation
TM5 Bus 5 Vdc current draw	50 mA	
24 Vdc I/O segment current draw	54.2 mA	
Certifications and standards	<ul style="list-style-type: none"> <li>• CE</li> <li>• UL508 (ULus)</li> <li>• IEC 61508</li> <li>• IEC 62061</li> </ul>	

General Characteristics	
	• EN 13849
Maximum internal cycle time	800 µs
Minimum cycle time	200 µs
Minimum I/O update time	400 µs
Id code for firmware update	7614 dec

**NOTE** <sup>(1)</sup> The isolation of the electronic module is 500 Vac RMS between the electronics power by the TM5 bus and those powered by 24 Vdc I/O power segment connected to the module. In practice, the electronic module is installed in the bus base, and there is a bridge between the TM5 power bus and the 24 Vdc I/O power segment. The two power circuits reference the same functional ground (FE) through specific components designed to reduce effects of electromagnetic interference. These components are rated at 30 Vdc or 60 Vdc. This effectively reduces isolation of the entire system from the 500 Vac RMS.

### Operating Conditions

The following table lists the operating conditions for the TM5SDO4TFS module:

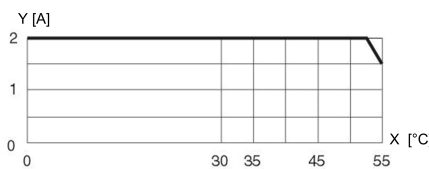
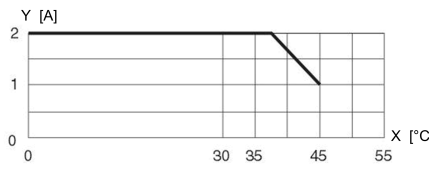
Operating Conditions		
Mounting orientation	horizontal or vertical	
Operating temperature	horizontal installation	0...+55 °C (+32...131 °F) Derating horizontal  <b>x-axis:</b> Ambient temperature [°C] <b>y-axis:</b> Output current [A] <b>NOTE:</b> If a TM5SD000 is installed on the side of the module, the horizontal installation derating is shifted to the right by the following derating bonus: <ul style="list-style-type: none"> <li>• TM5SD000 to the left: +2.5 °C (+4.5 °F)</li> <li>• TM5SD000 to the right: +0 °C (+0 °F)</li> <li>• TM5SD000 to the left and right: +5 °C (+9 °F)</li> </ul>
	vertical installation	0...+45 °C (+32...113 °F) Derating vertical  <b>x-axis:</b> Ambient temperature [°C] <b>y-axis:</b> Output current [A] <b>NOTE:</b> Using a TM5SD000 does not provide a derating bonus in vertical installation.
Relative humidity	5...95%	
Installation at altitudes above sea level:	0 up to 2000 m (0 up to 6561 ft)	no derating for altitude
	> 2000 m (>6561 ft)	reduction of ambient temperature by 0.5 °C per 100 m (0.9 °F per 328 ft)
EN 60529 Protection type	IP20	

## Storage and Transport Conditions

The following table lists the storage and transport conditions for the TM5SDO4TFS module:

Storage and Transport Conditions	
Temperature	-25...+70 °C (-13...+158 °F)
Relative humidity	5...95%

## Digital Output Characteristics

The following table lists the digital output characteristics of the TM5SDO4TFS module:

Digital Output	
Number of output channels	4
Rated voltage	24 Vdc
Rated output current	0.5 A
Total current	2.0 A
Output protection	<ul style="list-style-type: none"> <li>disable the channel in case of over-current or short circuit</li> <li>inductive load resistance</li> </ul>
Design	<ul style="list-style-type: none"> <li>FET, 1x n switching, 1x p switching, type A</li> <li>Output level can be read</li> <li>Open-circuit detection</li> </ul>
Switching voltage	24 Vdc (-15% / +20%)
Diagnostics status	Output monitoring with configurable delay
Leakage current when switched off	<10 µA
Residual voltage	< 120 mV at 0.5 A rated current without OSSD
Short circuit peak current	< 12 A
Test pulse length	Maximum 500 µs
Time between two test pulses	Minimum 49.5 ms
Re-arming after overload or short circuit detection	Set <code>ReleaseOutput0x</code> from 0 to 1. Then, after a positive edge on the <code>SafeDigitalOutput0x</code> channel, the output goes high.
Braking voltage when switching off inductive loads	typical: 40 Vdc
Maximum capacitive load	100 nF
Isolation voltage between channel and bus <sup>1)</sup>	See note.
Open circuit detection	Via internal current measurement <ul style="list-style-type: none"> <li>output current &lt;10 mA: Signal CurrentOK = FALSE</li> <li>output current &gt;50 mA: Signal CurrentOK = TRUE</li> </ul>
Error detection time	1 s

**NOTE** <sup>(1)</sup> The isolation of the electronic module is 500 Vac RMS between the electronics power by the TM5 bus and those powered by 24 Vdc I/O power segment connected to the module. In practice, the electronic module is installed in the bus base, and there is a bridge between the TM5 power bus and the 24 Vdc I/O power segment. The two power circuits reference the same functional ground (FE) through specific components designed to reduce effects of electromagnetic

interference. These components are rated at 30 Vdc or 60 Vdc. This effectively reduces isolation of the entire system from the 500 Vac RMS.

### Safety-Related Characteristics

The following table lists the safety-related characteristics of the TM5SDO4TFS module:

Criteria	Characteristic Value in DisableOSSD = No	Characteristic Value in DisableOSSD = Yes
Maximum performance level according to EN ISO 13849	PL e	PL d
Category according to EN ISO 13849	CAT 4	CAT 3
Maximum safety integrity level according to IEC 62061	SIL 3	SIL 2
Maximum safety integrity level according to IEC 61508	SIL 3	SIL 2
PFH	<math>1 \cdot 10^{-10}</math>	
PFD	<ul style="list-style-type: none"> <li>&lt;math&gt;1 \cdot 10^{-5}&lt;/math&gt; at a proof test interval of 10 years</li> <li>&lt;math&gt;2 \cdot 10^{-5}&lt;/math&gt; at a proof test interval of 20 years</li> </ul>	
PT	Maximum 20 years	
DC	>94%	>60%
SFF	>90%	>60%
MTTFd	2500 years	
Life time, page 26	20 years	

## TM5SDO4TFS Wiring

### Pin Assignments / Connection Example

The following figure presents a connection example for the TM5SDO4TFS:

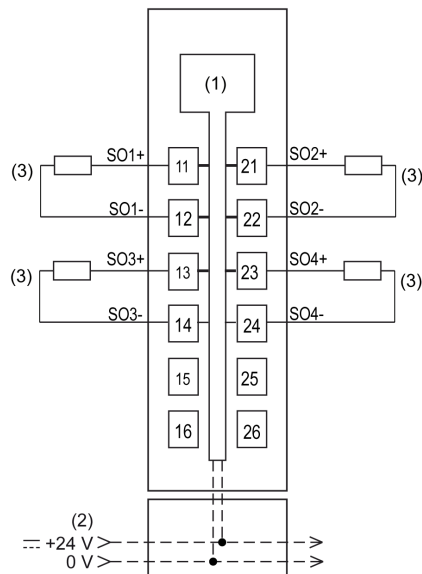

- 1 Internal electronics
- 2 24 Vdc I/O power segment integrated into the bus bases
- 3 Actuator 24 Vdc

**▲ WARNING****UNINTENDED EQUIPMENT OPERATION**

Do not connect wires to unused terminals and/or terminals indicated as “No Connection (N.C.)”.

**Failure to follow these instructions can result in death, serious injury, or equipment damage.**

**▲ WARNING****UNINTENDED EQUIPMENT OPERATION**

Use the sensor and actuator power supply only for supplying power to sensors or actuators connected to the module.

**Failure to follow these instructions can result in death, serious injury, or equipment damage.**

# TM5SDO4TAFS Safety Module 4DO 24 Vdc

## What's in This Chapter

TM5SDO4TAFS Presentation ..... 134  
 TM5SDO4TAFS Characteristics ..... 137  
 TM5SDO4TAFS Wiring ..... 141

## TM5SDO4TAFS Presentation

### Main Features

The following table describes the main features of the Safety Digital Output module TM5SDO4TAFS:

Main Features	
Number of Outputs	4
Output Type	safety-related digital FET outputs with current monitoring
Protective Features	open-circuit detection
	integrated over-current protection and inductive load resistance
Rated Output Current	2 A
Rated Voltage	24 Vdc

## ⚠ DANGER

### POTENTIAL FOR EXPLOSION

- Only use this equipment in non-hazardous locations or in locations that comply with Class I, Division 2, Groups A, B, C and D.
- Do not substitute components which would impair compliance to Class I, Division 2.
- Do not connect or disconnect equipment unless power has been removed or the location is known to be non-hazardous.

**Failure to follow these instructions will result in death or serious injury.**

## Ordering Information

The following figure presents the module in combination with the required components:

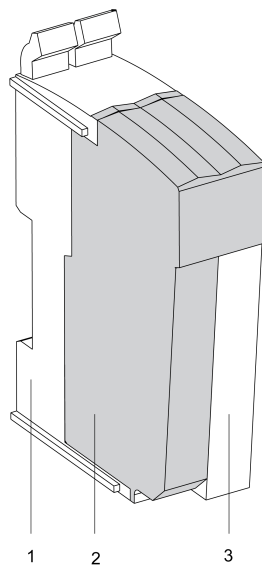

The following table presents the reference of the module:

Number	Model Number	Description	Color
2	TM5SDO4TAFS	TM5 Safety Digital Output module	red

The following table presents the references for the required components:

Number	Reference	Description	Color
1	TM5ACBM3-FS	TM5 Safety bus base, safety coded, internal I/O supply is interconnected	red
3	TM5ACTB52-FS	TM5 Safety terminal block, 12-pin, safety coded	red

**NOTE:** A TM5 Safety bus base and a TM5 Safety terminal block are required for operation of the module, and are sold separately. For more information, refer to TM5ACBM3FS Safety bus base, page 232 and TM5ACTB52FS Safety terminal block, page 238.

## Status LED Indicators

This figure presents the TM5SDO4TAFS status LED indicators:

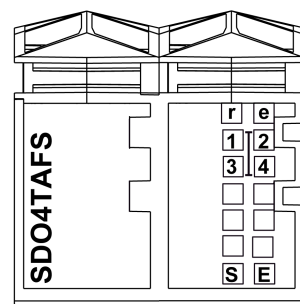

The following tables describe the status LED indicators:

LED indicator	Color	Status	Description
r	off		Module supply not connected.
	green	single flash	reset mode

LED indicator	Color	Status	Description
		double flash	firmware update in progress
		flashing	pre-operational state
		on	RUN state
e	off		No error detected or module supply not connected.
	red	flashing	boot loader mode
		triple flash	firmware update in progress
		on	error detected
r+e	steady red/single green flash	invalid configuration	

LED indicator	Color	Status	Description
1 2 3 4	red	on	Indicates either an error has been detected for the corresponding output or that the safety-related output is being used as a non-safety-related output.  <b>NOTE:</b> During the start-up phase, the channel LED indicators are steady red.
	orange	on	output set

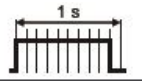
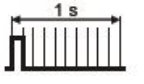
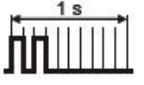
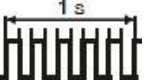
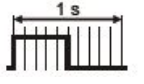
LED indicator	Color	Status	Description
S E	off		RUN state or 24 Vdc supply not present
	red		boot phase or missing TM5 link or non-functioning processor (refer to safety message below)
			pre-operational state
			communication channel is not OK
			firmware for this module is a non-certified pilot version  <b>NOTE:</b> If you observe this indication, you must immediately replace the module, or update its firmware with a certified version. In all cases, contact your Schneider Electric representative.
			boot phase, inoperable firmware
	on		Safety-related status is active.

Whenever the **S** and **E** LED indicators are illuminated continuously, this indicates that the module is inoperative. There is also a diagnostic available in the Safety Logic Controller to indicate this state. Replacement of the module must be made immediately. It is your responsibility to ensure all necessary repairs are made promptly to enable proper functionality.



<b>⚠ WARNING</b>	
<b>LOSS OF SAFETY FUNCTION</b>	
<ul style="list-style-type: none"> <li>• Immediately replace any and all modules that indicate that they are in an inoperable state.</li> <li>• Ensure that the effect on un-repaired equipment is taken into account in your risk assessment.</li> <li>• Make all necessary repairs to equipment before re-starting, or continuing service of, your machine.</li> </ul>	
<b>Failure to follow these instructions can result in death, serious injury, or equipment damage.</b>	

## TM5SDO4TAFS Characteristics

### Introduction

This section describes the characteristics of the TM5SDO4TAFS module. See also TM5 Environmental Characteristics, page 26.

<b>⚠ DANGER</b>	
<b>FIRE HAZARD</b>	
Use only the correct wire sizes for the maximum current capacity of the I/O channels and power supplies.	
<b>Failure to follow these instructions will result in death or serious injury.</b>	

<b>⚠ WARNING</b>	
<b>UNINTENDED EQUIPMENT OPERATION</b>	
Do not exceed any of the rated values specified in the environmental and electrical characteristics tables.	
<b>Failure to follow these instructions can result in death, serious injury, or equipment damage.</b>	

### General Characteristics

The following table lists the general characteristics of the TM5SDO4TAFS module:

General Characteristics		
Rated power supply voltage		24 Vdc
Status indicators		<ul style="list-style-type: none"> <li>• I/O functions per channel</li> <li>• operating state</li> <li>• module status</li> </ul>
Diagnostics		Module run and detected error conditions indicated by status LED indicator and software status.
Electrical isolation <sup>1)</sup>	channel - bus	See note.
	channel - channel	no galvanic isolation
TM5 Bus 5 Vdc current draw		50 mA
24 Vdc I/O segment current draw		54.2 mA
Certifications and standards		<ul style="list-style-type: none"> <li>• CE</li> <li>• UL508 (ULus)</li> <li>• IEC 61508</li> </ul>

General Characteristics	
	<ul style="list-style-type: none"> <li>• IEC 62061</li> <li>• EN 13849</li> </ul>
Maximum internal cycle time	800 µs
Minimum cycle time	200 µs
Minimum I/O update time	400 µs
Id code for firmware update	8199 dec

**NOTE** <sup>(1)</sup> The isolation of the electronic module is 500 Vac RMS between the electronics power by the TM5 bus and those powered by 24 Vdc I/O power segment connected to the module. In practice, the electronic module is installed in the bus base, and there is a bridge between the TM5 power bus and the 24 Vdc I/O power segment. The two power circuits reference the same functional ground (FE) through specific components designed to reduce effects of electromagnetic interference. These components are rated at 30 Vdc or 60 Vdc. This effectively reduces isolation of the entire system from the 500 Vac RMS.

## Operating Conditions

The following table lists the operating conditions for the TM5SDO4TAFS module:

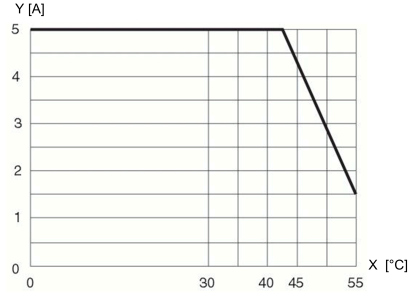
Operating Conditions		
Mounting orientation		horizontal or vertical
Operating temperature	horizontal installation	0...+55 °C (+32...131 °F)  Derating horizontal:   x-axis: Ambient temperature [°C] y-axis: Output current [A]
	vertical installation	0...+45 °C (+32...113 °F)

**NOTE:** If a TM5SD000 is installed on the side of the module, the horizontal installation derating is shifted to the right by the following derating bonus:

- TM5SD000 to the left: +2.5 °C (+4.5 °F)
- TM5SD000 to the right: +0 °C (+0 °F)
- TM5SD000 to the left and right: +5 °C (+9 °F)

Operating Conditions		
		<p>Derating vertical:</p> <p><b>x-axis:</b> Ambient temperature [°C]  <b>y-axis:</b> Output current [A]</p> <p><b>NOTE:</b> Using a TM5SD000 does not provide a derating bonus in vertical installation.</p>
Relative humidity		5...95%
Installation at altitudes above sea level:	0 up to 2000 m (0 up to 6561 ft)	no derating for altitude
	> 2000 m (>6561 ft)	reduction of ambient temperature by 0.5 °C per 100 m (0.9 °F per 328 ft)
EN 60529 Protection type		IP20

### Storage and Transport Conditions

The following table lists the storage and transport conditions for the TM5SDO4TAFS module:

Storage and Transport Conditions	
Temperature	-25...+70 °C (-13...+158 °F)
Relative humidity	5...95%

### Digital Output Characteristics

The following table lists the digital output characteristics of the TM5SDO4TAFS module:

Digital Output	
Number of output channels	4
Rated voltage	24 Vdc
Rated output current	2.0 A
Total current	5.0 A
Output protection	<ul style="list-style-type: none"> <li>• disable the channel in case of over-current or short circuit</li> <li>• inductive load resistance</li> </ul>
Design	<ul style="list-style-type: none"> <li>• FET, 1x n switching, 1x p switching, type A</li> <li>• Output level can be read</li> <li>• Open-circuit detection</li> </ul>
Switching voltage	20.4...28.8 Vdc
Diagnostics status	Output monitoring with configurable delay
Leakage current when switched off	<10 µA
Residual voltage	< 480 mV at 2 A rated current without OSSD

Digital Output	
Short circuit peak current	< 12 A
Test pulse length	Maximum 500 $\mu$ s
Time between two test pulses	Minimum 49.5 ms
Re-arming after overload or short circuit detection	Set <code>ReleaseOutput0x</code> from 0 to 1. Then, after a positive edge on the <code>SafeDigitalOutput0x</code> channel, the output goes high.
Braking voltage when switching off inductive loads	typical: 40 Vdc
Maximum capacitive load	100 nF
Isolation voltage between channel and bus <sup>1)</sup>	See note.
Open circuit detection	Via internal current measurement <ul style="list-style-type: none"> <li>output current &lt;10 mA: Signal CurrentOK = FALSE</li> <li>output current &gt;50 mA: Signal CurrentOK = TRUE</li> </ul>
Error detection time	1 s

**NOTE** <sup>(1)</sup> The isolation of the electronic module is 500 Vac RMS between the electronics power by the TM5 bus and those powered by 24 Vdc I/O power segment connected to the module. In practice, the electronic module is installed in the bus base, and there is a bridge between the TM5 power bus and the 24 Vdc I/O power segment. The two power circuits reference the same functional ground (FE) through specific components designed to reduce effects of electromagnetic interference. These components are rated at 30 Vdc or 60 Vdc. This effectively reduces isolation of the entire system from the 500 Vac RMS.

## Safety-Related Characteristics

The following table lists the safety-related characteristics of the TM5SDO4TAFS module:

Criteria	Characteristic Value in DisableOSSD = No	Characteristic Value in DisableOSSD = Yes
Maximum performance level according to EN ISO 13849	PL e	PL d
Category according to EN ISO 13849	CAT 4	CAT 3
Maximum safety integrity level according to IEC 62061	SIL 3	SIL 2
Maximum safety integrity level according to IEC 61508	SIL 3	SIL 2
PFH	<1*10 <sup>-10</sup>	
PFD	<ul style="list-style-type: none"> <li>&lt;1*10<sup>-5</sup> at a proof test interval of 10 years</li> <li>&lt;2*10<sup>-5</sup> at a proof test interval of 20 years</li> </ul>	
PT	Maximum 20 years	
DC	>94%	>60%
SFF	>90%	>60%
MTTFd	2500 years	
Life time, page 26	20 years	

# TM5SDO4TAFS Wiring

## Pin Assignments / Connection Example

The following figure presents a connection example for the TM5SDO4TAFS:

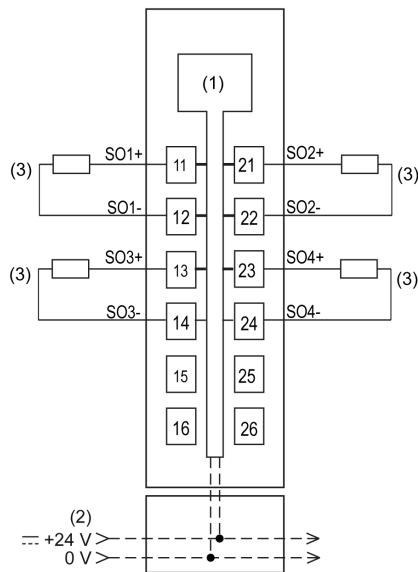

- 1 Internal electronics
- 2 24 Vdc I/O power segment integrated into the bus bases
- 3 Actuator 24 Vdc

<b>⚠ WARNING</b>
<p><b>UNINTENDED EQUIPMENT OPERATION</b></p> <p>Do not connect wires to unused terminals and/or terminals indicated as “No Connection (N.C.)”.</p> <p><b>Failure to follow these instructions can result in death, serious injury, or equipment damage.</b></p>

<b>⚠ WARNING</b>
<p><b>UNINTENDED EQUIPMENT OPERATION</b></p> <p>Use the sensor and actuator power supply only for supplying power to sensors or actuators connected to the module.</p> <p><b>Failure to follow these instructions can result in death, serious injury, or equipment damage.</b></p>

# TM5SDO6TBFS Safety Module 6DO 24 Vdc

## What's in This Chapter

TM5SDO6TBFS Presentation ..... 142  
 TM5SDO6TBFS Characteristics ..... 145  
 TM5SDO6TBFS Wiring ..... 149

## TM5SDO6TBFS Presentation

### Main Features

The table describes the main features of the Safety Digital Output module TM5SDO6TBFS:

Main Features	
Number of Outputs	6
Output Type	safety-related digital FET outputs with current monitoring
Protective Features	active cutoff for overcurrent or short circuit
	integrated protection for switching inductances
Rated Output Current	0.2 A
Total Rated Current	1.2 A
Rated Voltage	24 Vdc

## ⚠ DANGER

### POTENTIAL FOR EXPLOSION

- Only use this equipment in non-hazardous locations or in locations that comply with Class I, Division 2, Groups A, B, C and D.
- Do not substitute components which would impair compliance to Class I, Division 2.
- Do not connect or disconnect equipment unless power has been removed or the location is known to be non-hazardous.

**Failure to follow these instructions will result in death or serious injury.**

## Ordering Information

The following figure presents the module in combination with the required components:

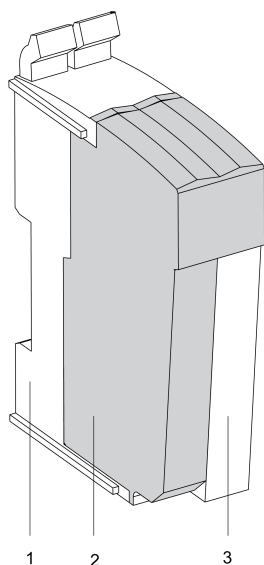

The following table presents the reference of the module:

Number	Model Number	Description	Color
2	TM5SDO6TBFS	TM5 Safety Digital Output module	red

The following table presents the references for the required components:

Number	Reference	Description	Color
1	TM5ACBM3-FS	TM5 Safety bus base, safety coded, internal I/O supply is interconnected	red
3	TM5ACTB52-FS	TM5 Safety terminal block, 12-pin, safety coded	red
<p><b>NOTE:</b> A TM5 Safety bus base and a TM5 Safety terminal block are required for operation of the module, and are sold separately. For more information, refer to TM5ACBM3FS Safety bus base, page 232 and TM5ACTB52FS Safety terminal block, page 238.</p>			

## Status LED Indicators

This figure presents the TM5SDO6TBFS status LED indicators:

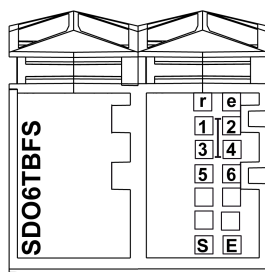

The following tables describe the status LED indicators:

LED indicator	Color	Status	Description
r	off		Module supply not connected.
	green	single flash	reset mode

LED indicator	Color	Status	Description
		double flash	firmware update in progress
		flashing	pre-operational state
		on	RUN state
e	off		No error detected or module supply not connected.
	red	flashing	boot loader mode
		triple flash	firmware update in progress
		on	error detected
r+e	steady red/single green flash	invalid configuration	

LED indicator	Color	Status	Description
1 ... 6	red	on	Indicates either an error has been detected for the corresponding output or that the safety-related output is being used as a non-safety-related output.  <b>NOTE:</b> During the start-up phase, the channel LED indicators are steady red.
	orange	on	output set

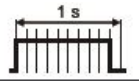
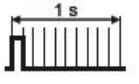
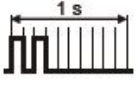
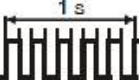
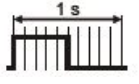
LED indicator	Color	Status	Description
S E	off		RUN state or 24 Vdc supply not present
	red		boot phase or missing TM5 link or non-functioning processor (refer to safety message below)
			pre-operational state
			communication channel is not OK
			firmware for this module is a non-certified pilot version  <b>NOTE:</b> If you observe this indication, you must immediately replace the module, or update its firmware with a certified version. In all cases, contact your Schneider Electric representative.
			boot phase, inoperable firmware
	on		Safety-related status is active.

Whenever the **S** and **E** LED indicators are illuminated continuously, this indicates that the module is inoperative. There is also a diagnostic available in the Safety Logic Controller to indicate this state. Replacement of the module must be made immediately. It is your responsibility to ensure all necessary repairs are made promptly to enable proper functionality.



<b>⚠ WARNING</b>
<p><b>LOSS OF SAFETY FUNCTION</b></p> <ul style="list-style-type: none"> <li>• Immediately replace any and all modules that indicate that they are in an inoperable state.</li> <li>• Ensure that the effect on un-repaired equipment is taken into account in your risk assessment.</li> <li>• Make all necessary repairs to equipment before re-starting, or continuing service of, your machine.</li> </ul> <p><b>Failure to follow these instructions can result in death, serious injury, or equipment damage.</b></p>

## TM5SDO6TBFS Characteristics

### Introduction

This section describes the characteristics of the TM5SDO6TBFS module. See also TM5 Environmental Characteristics, page 26.

<b>⚠ DANGER</b>
<p><b>FIRE HAZARD</b></p> <p>Use only the correct wire sizes for the maximum current capacity of the I/O channels and power supplies.</p> <p><b>Failure to follow these instructions will result in death or serious injury.</b></p>

<b>⚠ WARNING</b>
<p><b>UNINTENDED EQUIPMENT OPERATION</b></p> <p>Do not exceed any of the rated values specified in the environmental and electrical characteristics tables.</p> <p><b>Failure to follow these instructions can result in death, serious injury, or equipment damage.</b></p>

### General Characteristics

The table lists the general characteristics of the TM5SDO6TBFS module:

General Characteristics		
Rated power supply voltage		24 Vdc
Status indicators		<ul style="list-style-type: none"> <li>• I/O functions per channel</li> <li>• operating state</li> <li>• module status</li> </ul>
Diagnostics		Module run and detected error conditions indicated by status LED indicator and software status.
Electrical isolation <sup>1)</sup>	channel - bus	See note.
	channel - channel	no galvanic isolation
TM5 Bus 5 Vdc current draw		64 mA
24 Vdc I/O segment current draw		58.3 mA
Certifications and standards		<ul style="list-style-type: none"> <li>• CE</li> <li>• UL508 (ULus)</li> <li>• IEC 61508</li> </ul>

General Characteristics	
	<ul style="list-style-type: none"> <li>• IEC 62061</li> <li>• EN 13849</li> </ul>
Minimum safety-related response time	6 ms
Maximum internal cycle time	1 ms
Minimum cycle time	200 µs
Minimum I/O update time	500 µs
Id code for firmware update	47125 dec

**NOTE** <sup>(1)</sup> The isolation of the electronic module is 500 Vac RMS between the electronics power by the TM5 bus and those powered by 24 Vdc I/O power segment connected to the module. In practice, the electronic module is installed in the bus base, and there is a bridge between the TM5 power bus and the 24 Vdc I/O power segment. The two power circuits reference the same functional ground (FE) through specific components designed to reduce effects of electromagnetic interference. These components are rated at 30 Vdc or 60 Vdc. This effectively reduces isolation of the entire system from the 500 Vac RMS.

## Operating Conditions

The table lists the operating conditions for the TM5SDO6TBFS module:

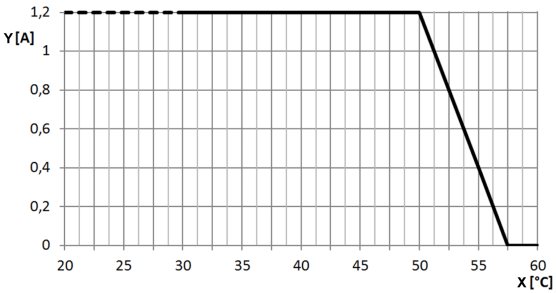
Operating Conditions		
Mounting orientation	horizontal or vertical	
Operating temperature	horizontal installation	0...+55 °C (+32...131 °F) Derating horizontal:  x-axis: Ambient temperature [°C] y-axis: Output current <b>NOTE:</b> If a TM5SD000 is installed on the side of the module, the horizontal installation derating is shifted to the right by the following derating bonus: <ul style="list-style-type: none"> <li>• TM5SD000 to the left: +2.5 °C (+4.5 °F)</li> <li>• TM5SD000 to the right: +0 °C (+0 °F)</li> <li>• TM5SD000 to the left and right: +5 °C (+9 °F)</li> </ul>
	vertical installation	0...+40 °C (+32...104 °F)

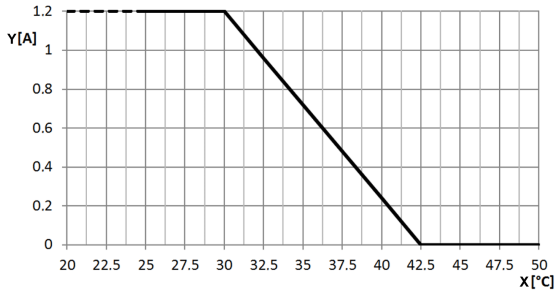
Operating Conditions		
		Derating vertical:  <p> <b>x-axis:</b> Ambient temperature [°C]  <b>y-axis:</b> Output current  <b>NOTE:</b> Using a TM5SD000 does not provide a derating bonus in vertical installation.                     </p>
Relative humidity		5...95%
Installation at altitudes above sea level:	0 up to 2000 m (0 up to 6561 ft)	no derating for altitude
	> 2000 m (>6561 ft)	reduction of ambient temperature by 0.5 °C per 100 m (0.9 °F per 328 ft)
EN 60529 Protection type		IP20

### Storage and Transport Conditions

The table lists the storage and transport conditions for the TM5SDO6TBFS module:

Storage and Transport Conditions	
Temperature	-25...+70 °C (-13...+158 °F)
Relative humidity	5...95%

### Digital Output Characteristics

The table lists the digital output characteristics of the TM5SDO6TBFS module:

Digital Output	
Number of output channels	6
Rated voltage	24 Vdc
Voltage range	20.4...28.8 Vdc
Rated output current	0.2 A
Total rated current	1.2 A
Integrated protection	reverse polarity protection
Output protection	<ul style="list-style-type: none"> <li>active cutoff for over-current and short circuit</li> <li>inductive load resistance</li> </ul>
Design	<ul style="list-style-type: none"> <li>FET, 2x n switching, type B</li> <li>Output level can be read</li> </ul>
Switching voltage	Module supply minus residual voltage
Diagnostics status	Output monitoring with configurable delay
Leakage current when switched off	<100 µA
Residual voltage	< 800 mV at rated current
Short circuit peak current	typical: 3.5 A

Digital Output	
Test pulse length	Maximum 10 $\mu$ s
Re-arming after overload or short circuit detection	Set <code>ReleaseOutput0x</code> from 0 to 1. Then, after a positive edge on the <code>SafeDigitalOutput0x</code> channel, the output goes high.
Braking voltage when switching off inductive loads	typical: 40 Vdc
Maximum capacitive load	100 nF
Peak output current	typical: 0.37 A
Isolation voltage between channel and bus <sup>1)</sup>	See note.
Error detection time	1 s

**NOTE** <sup>(1)</sup> The isolation of the electronic module is 500 Vac RMS between the electronics power by the TM5 bus and those powered by 24 Vdc I/O power segment connected to the module. In practice, the electronic module is installed in the bus base, and there is a bridge between the TM5 power bus and the 24 Vdc I/O power segment. The two power circuits reference the same functional ground (FE) through specific components designed to reduce effects of electromagnetic interference. These components are rated at 30 Vdc or 60 Vdc. This effectively reduces isolation of the entire system from the 500 Vac RMS.

## Safety-Related Characteristics

The table lists the safety-related characteristics of the TM5SDO6TBFS module:

Criteria	Characteristic Value in DisableOSSD = No	Characteristic Value in DisableOSSD = Yes
Maximum performance level according to EN ISO 13849-1:2008	PL e	PL d
Category according to EN ISO 13849-1:2008	CAT 4	CAT 3
Maximum safety integrity level according to IEC 62061:2005	SIL 3	SIL 2
Maximum safety integrity level according to IEC 61508:2010	SIL 3	SIL 2
PFH	<1*10 <sup>-10</sup>	
PFD	<ul style="list-style-type: none"> <li>• &lt;1*10<sup>-5</sup> at a proof test interval of 10 years</li> <li>• &lt;2*10<sup>-5</sup> at a proof test interval of 20 years</li> </ul>	
PT	Maximum 20 years	
DC	>94%	>60%
SFF	>90%	>60%
MTTFd	2500 years	
Life time, page 26	20 years	

# TM5SDO6TBFS Wiring

## Connection Example

The following figure presents a connection example for the TM5SDO6TBFS:

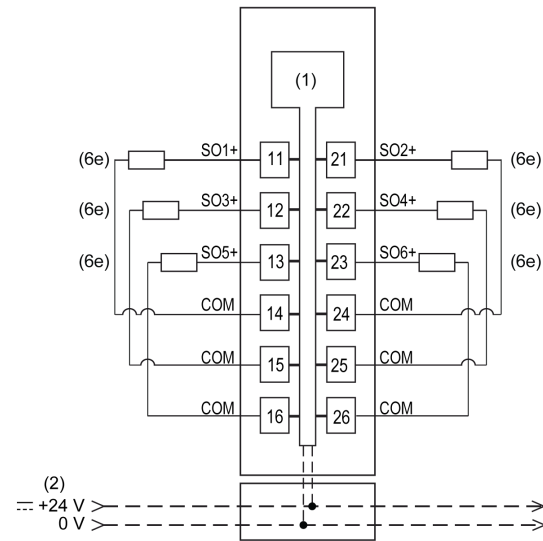

**1** Internal electronics

**2** 24 Vdc I/O power segment integrated into the bus bases

**6e** Actuator 24 Vdc

### **▲ WARNING**

#### **UNINTENDED EQUIPMENT OPERATION**

Do not connect wires to unused terminals and/or terminals indicated as “No Connection (N.C.)”.

**Failure to follow these instructions can result in death, serious injury, or equipment damage.**

# TM5/TM7 Safety Digital Mixed Modules

## What's in This Part

TM5SDM4DTRFS Safety Module 2DI 2DO 48 Vac/6 A, 24 Vdc/6 A.....	151
TM5SDM8TBFS Safety Module 6DI 2DO 24 Vdc.....	161
TM7SDM12DTFS Safety Module 8DI 4DO 24 Vdc .....	170

# TM5SDM4DTRFS Safety Module 2DI 2DO 48 Vac/6 A, 24 Vdc/6 A

## What's in This Chapter

TM5SDM4DTRFS Presentation ..... 151  
 TM5SDM4DTRFS Characteristics ..... 154  
 TM5SDM4DTRFS Wiring..... 160

## TM5SDM4DTRFS Presentation

### Main Features

The following table describes the main features of the Safety Digital Mixed module TM5SDM4DTRFS:

Main Features	
Number of Inputs	2 safety-related inputs
Input Type	safety-related inputs and configurable input filter
Number of Outputs	2 safety-related relay outputs
Output Type	test (pulse) outputs and safety-related relay outputs
Rated Voltage	24 Vdc

### **⚠ DANGER**

#### **POTENTIAL FOR EXPLOSION**

- Only use this equipment in non-hazardous locations or in locations that comply with Class I, Division 2, Groups A, B, C and D.
- Do not substitute components which would impair compliance to Class I, Division 2.
- Do not connect or disconnect equipment unless power has been removed or the location is known to be non-hazardous.

**Failure to follow these instructions will result in death or serious injury.**

## Ordering Information

The following figure presents the module in combination with the required components:

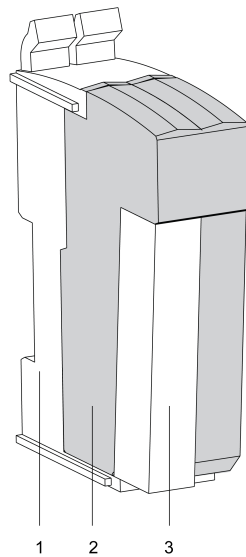

The following table presents the reference of the module:

Number	Model Number	Description	Color
2	TM5SDM4DTRFS	TM5 Safety Digital Mixed module	red

The following table presents the references for the required components:

Number	Reference	Description	Color
1	TM5ACBM3-FS	TM5 Safety bus base, safety coded, internal I/O supply is interconnected	red
3	TM5ACTB52-FS	TM5 Safety terminal block, 12-pin, safety coded	red

**NOTE:** A TM5 Safety bus base and a TM5 Safety terminal block are required for operation of the module, and are sold separately. For more information, refer to TM5ACBM3FS Safety bus base, page 232 and TM5ACTB52FS Safety terminal block, page 238.

## Status LED Indicators

This figure presents the TM5SDM4DTRFS status LED indicators:

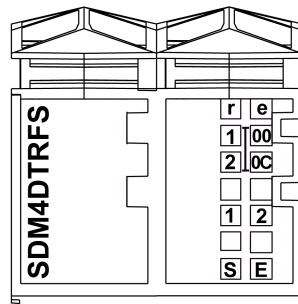

The following tables describe the status LED indicators:

LED indicator	Color	Status	Description
r	off		Module supply not connected.



LED indicator	Color	Status	Description
	green	single flash	reset mode
		double flash	firmware update in progress
		flashing	pre-operational state
		on	RUN state
e	off		No error detected or module supply not connected.
	red	flashing	boot loader mode
		triple flash	firmware update in progress
		on	error detected
r+e	steady red/single green flash		invalid configuration

LED indicator	Color	Status	Description
1 2	red	on	Indicates either an error has been detected for the corresponding input or that the safety-related input is being used as a non-safety-related input.  <b>NOTE:</b> When there is no connection to the Safety Logic Controller, all channels are steady red.
OO			open - open: 2-channel evaluation on channels 1 and 2.  <b>NOTE:</b> Detected errors in the two-channel evaluation will be indicated by means of the individual channel LED indicators.
	red	on	Indicates a detected evaluation channel error.
	green	on	Evaluation channel is set.
OC			open - closed: 2 channel evaluation on channels 1 and 2.  <b>NOTE:</b> Detected errors in the two-channel evaluation will be indicated by means of the individual channel LED indicators.
	red	on	Indicates a detected evaluation channel error.
	green	on	Evaluation channel is set.

LED indicator	Color	Status	Description
1 2	red	on	Indicates either an error has been detected for the corresponding output or that the safety-related output is being used as a non-safety-related output.  <b>NOTE:</b> During the start-up phase, the channel LED indicators are steady red.

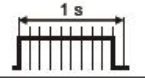
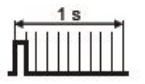
LED indicator	Color	Status	Description
S E	off		RUN state or 24 Vdc supply not present
	red		boot phase or missing TM5 link or non-functioning processor (refer to safety message below)
			pre-operational state

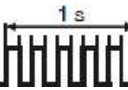
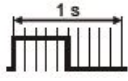
LED indicator	Color	Status	Description
			communication channel is not OK
			firmware for this module is a non-certified pilot version <b>NOTE:</b> If you observe this indication, you must immediately replace the module, or update its firmware with a certified version. In all cases, contact your Schneider Electric representative.
			boot phase, inoperable firmware
		on	Safety-related status is active.

Whenever the **S** and **E** LED indicators are illuminated continuously, this indicates that the module is inoperative. There is also a diagnostic available in the Safety Logic Controller to indicate this state. Replacement of the module must be made immediately. It is your responsibility to ensure all necessary repairs are made promptly to enable proper functionality.

## ⚠ WARNING

### LOSS OF SAFETY FUNCTION

- Immediately replace any and all modules that indicate that they are in an inoperable state.
- Ensure that the effect on un-repaired equipment is taken into account in your risk assessment.
- Make all necessary repairs to equipment before re-starting, or continuing service of, your machine.

**Failure to follow these instructions can result in death, serious injury, or equipment damage.**

## TM5SDM4DTRFS Characteristics

### Introduction

This section describes the characteristics of the TM5SDM4DTRFS module. See also TM5 Environmental Characteristics, page 26.

## ⚠ DANGER

### FIRE HAZARD

- Use only the correct wire sizes for the current capacity of the I/O channels and power supplies.
- For relay output (2 A) wiring, use conductors of at least 0.5 mm<sup>2</sup> (AWG 20) with a temperature rating of at least 80 °C (176 °F).
- For common conductors of relay output wiring (6 A), or relay output wiring greater than 2 A, use conductors of at least 1.0 mm<sup>2</sup> (AWG 16) with a temperature rating of at least 80 °C (176 °F).

**Failure to follow these instructions will result in death or serious injury.**

<b>⚠ WARNING</b>
<b>UNINTENDED EQUIPMENT OPERATION</b>
Do not exceed any of the rated values specified in the environmental and electrical characteristics tables.
<b>Failure to follow these instructions can result in death, serious injury, or equipment damage.</b>

## General Characteristics

The following table lists the general characteristics of the TM5SDM4DTRFS module:

General Characteristics		
Rated power supply voltage		24 Vdc
Status indicators		<ul style="list-style-type: none"> <li>I/O functions per channel</li> <li>operating state</li> <li>module status</li> </ul>
Diagnostics	module run and detected error	indicated by status LED indicator and software status
	inputs	indicated by status LED indicator
	outputs	indicated by status LED indicator and software status (detected output error status)
Electrical isolation <sup>1)</sup>	channel - bus	See note.
	channel - channel	See note.
TM5 Bus 5 Vdc current draw		52 mA
24 Vdc I/O segment current draw		47.9 mA
Certifications and standards		<ul style="list-style-type: none"> <li>CE</li> <li>UL508 (ULus)</li> <li>IEC 61508</li> <li>IEC 62061</li> <li>EN 13849</li> </ul> Relay: <ul style="list-style-type: none"> <li>EN 50155</li> <li>EN 50205</li> </ul>
Maximum internal cycle time		1 ms
Minimum cycle time		200 μs
Minimum I/O update time		500 μs
Id code for firmware update		42916 dec

**NOTE** <sup>(1)</sup> The isolation of the electronic module is 500 Vac RMS between the electronics power by the TM5 bus and those powered by 24 Vdc I/O power segment connected to the module. In practice, the electronic module is installed in the bus base, and there is a bridge between the TM5 power bus and the 24 Vdc I/O power segment. The two power circuits reference the same functional ground (FE) through specific components designed to reduce effects of electromagnetic interference. These components are rated at 30 Vdc or 60 Vdc. This effectively reduces isolation of the entire system from the 500 Vac RMS.

## Operating Conditions

The following table lists the operating conditions for the TM5SDM4DTRFS module:

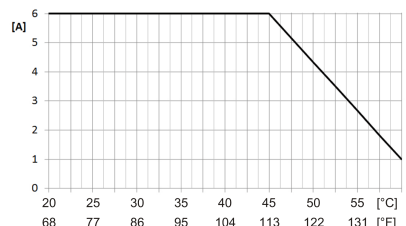
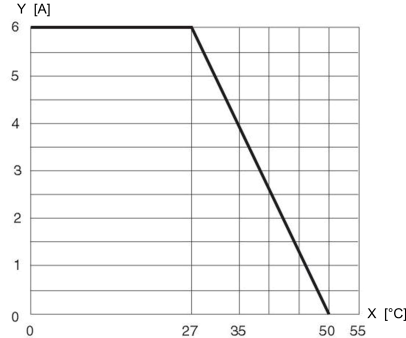
Operating Conditions		
Mounting orientation		horizontal or vertical
Operating temperature	horizontal installation	0...+55 °C (+32...131 °F) Derating - horizontal  <p><b>x-axis:</b> Ambient temperature [°C]  <b>y-axis:</b> Output current [A]</p> <p><b>NOTE:</b> If a TM5SD000 is installed on the side of the module, the horizontal installation derating is shifted to the right by the following derating bonus:</p> <ul style="list-style-type: none"> <li>• TM5SD000 to the left: +0 °C (+0 °F)</li> <li>• TM5SD000 to the right: +2.5 °C (+4.5 °F)</li> <li>• TM5SD000 to the left and right: +2.5 °C (+4.5 °F)</li> </ul>
	vertical installation	0...+45 °C (+32...113 °F) Derating - vertical  <p><b>x-axis:</b> Ambient temperature [°C]  <b>y-axis:</b> Output current [A]</p> <p><b>NOTE:</b> Using a TM5SD000 does not provide a derating bonus in vertical installation.</p>
Relative humidity		5...95%
Installation at altitudes above sea level:	0 up to 2000 m (0 up to 6561 ft)	no derating for altitude
	> 2000 m (>6561 ft)	reduction of ambient temperature by 0.5 °C per 100 m (0.9 °F per 328 ft)
EN 60529 Protection type		IP20

### Storage and Transport Conditions

The following table lists the storage and transport conditions for the TM5SDM4DTRFS module:

Storage and Transport Conditions	
Temperature	-25...+70 °C (-13...+158 °F)
Relative humidity	5...95%

## Safety-Related Digital Input Characteristics

The following table lists the safety-related digital input characteristics of the TM5SDM4DTRFS module:

Digital Input		
Number of input channels		2
Rated voltage		24 Vdc
Input filter	hardware	≤150 μs
	software	default: 0 ms, configurable between 0 and 500 ms
Input circuit		sink
Input voltage range		20.4...28.8 Vdc
Input current at 24 Vdc		typical: 3.3 mA
Input resistance		typical: 7.3 kΩ
OFF state (switching threshold low)		<5 Vdc
ON state (switching threshold high)		>15 Vdc
Isolation voltage between channel and bus <sup>1)</sup>		See note.
Error detection time		100 ms

**NOTE** <sup>(1)</sup> The isolation of the electronic module is 500 Vac RMS between the electronics power by the TM5 bus and those powered by 24 Vdc I/O power segment connected to the module. In practice, the electronic module is installed in the bus base, and there is a bridge between the TM5 power bus and the 24 Vdc I/O power segment. The two power circuits reference the same functional ground (FE) through specific components designed to reduce effects of electromagnetic interference. These components are rated at 30 Vdc or 60 Vdc. This effectively reduces isolation of the entire system from the 500 Vac RMS.

## Digital Test (Pulse) Output Characteristics

The following table lists the digital test (pulse) output characteristics of the TM5SDM4DTRFS module:

Digital Test Output	
Design	push-pull
Switching voltage	20.4...28.8 Vdc
Rated output current	50 mA
Total current	100 mA
Output protection	disable individual channels for over-current or short circuit.
Short circuit current	typical: 30 mA for 1 ms
Short circuit peak current	typical: 7 A for 1 ms
Diagnostics status	output monitoring
Maximum cable length	50 m / 164 ft (shielded)

## Relay Output Characteristics

The following table lists the relay output characteristics of the TM5SDM4DTRFS module:

Relay Output	
Switching voltage range	5...24 Vdc, 5...48 Vac
Switching current range	5 mA...6 A

Relay Output		
Turn-around time on relay	maximum 50 ms	
Design	<ul style="list-style-type: none"> <li>1 normally open contact</li> <li>internal high-side and low-side control</li> </ul>	
Coil voltage	24 Vdc (-15% / +20%)	
Contact resistance (without terminal block)	typical: 20 mΩ	
Maximum switching capacity	AC1	48 Vac / 6 A
	AC15	48 Vac / 3 A
	DC1	24 Vdc / 6 A
	DC13	24 Vdc / 5 A / 0.1 Hz
Contact lifespan	<p><b>x-axis:</b> switching current (A) <b>y-axis:</b> switching cycle x 1000</p>	
Peak (inrush) current	30 A for 20 ms	
The outputs must be protected against overload and short-circuit with an external fuse.	external 6 A gL/gG fuse (slow-blow fuse)	
Isolation voltage between channel and bus	300 Vac according to EN 50178	
Isolation voltage between channel and channel	48 Vac	

## Safety-Related Characteristics

The following table lists the safety-related characteristics of the TM5SDM4DTRFS module:

Criteria	Characteristic Value for input channels	Characteristic Value for relay channel
Maximum performance level according to EN ISO 13849	PL e	
Category according to EN ISO 13849	<ul style="list-style-type: none"> <li>CAT 3 for the use of single input channels.</li> <li>CAT 4 for the use of input channel pairs (for example SI1 and SI2) or more.</li> </ul>	<ul style="list-style-type: none"> <li>CAT 2 for the single use of the relay channels.</li> <li>CAT 4 for the use of both relay channels in series connection.</li> </ul>
Maximum safety integrity level according to IEC 62061	SIL 3	
Maximum safety integrity level according to IEC 61508	SIL 3	
PFH	<1*10 <sup>-10</sup>	can be disregarded
PFD	<ul style="list-style-type: none"> <li>&lt;1*10<sup>-5</sup> at a proof test interval of 10 years</li> <li>&lt;2*10<sup>-5</sup> at a proof test interval of 20 years</li> </ul>	

Criteria	Characteristic Value for input channels	Characteristic Value for relay channel
PT	Maximum 20 years	
MTTFd	2500 years	
DC	>94%	-
SFF	>90%	-
Life time, page 26	20 years	
<ul style="list-style-type: none"> <li>• B10d at DC1</li> <li>• 6 A</li> <li>• 24 Vdc</li> </ul>	not applicable	780,000 cycles
<ul style="list-style-type: none"> <li>• B10d at AC1</li> <li>• 6 A</li> <li>• 48 Vac</li> </ul>		780,000 cycles
<ul style="list-style-type: none"> <li>• B10d at AC15</li> <li>• 3 A</li> <li>• 48 Vac</li> </ul>		1,960,000 cycles
<ul style="list-style-type: none"> <li>• B10d at DC13</li> <li>• 5 A</li> <li>• 24 Vdc</li> </ul>		780,000 cycles

**NOTE:** The B10d values and the DC of 99% only apply, when the relay is activated at least once a year.

## TM5SDM4DTRFS Wiring

### Pin Assignments / Connection Example

The following figure presents a connection example for the TM5SDM4DTRFS:

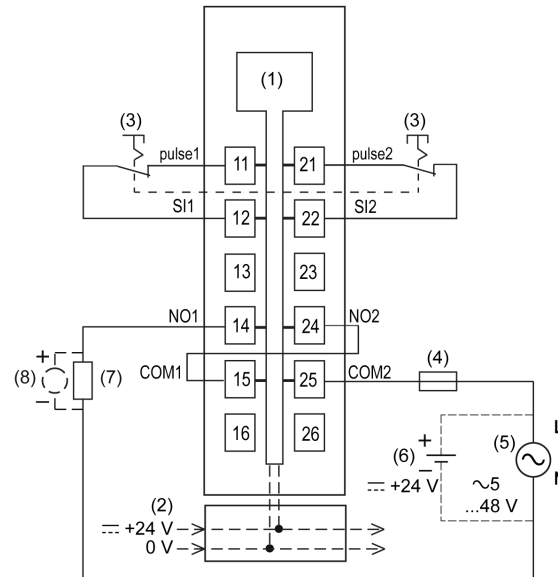

- 1 Internal electronics
- 2 24 Vdc I/O power segment integrated into the bus bases
- 3 2-wire sensor
- 4 External fuse sized to the load and its characteristics, maximum, 6 A
- 5 External power supply, 5...48 Vac
- 6 External power supply, 24 Vdc
- 7 Actuator 2-wire load
- 8 Inductive load protection

### ⚠ WARNING

#### UNINTENDED EQUIPMENT OPERATION

Do not connect wires to unused terminals and/or terminals indicated as "No Connection (N.C.)".

**Failure to follow these instructions can result in death, serious injury, or equipment damage.**

### ⚠ WARNING

#### UNINTENDED EQUIPMENT OPERATION

Only use the test (pulse) outputs for the intended purpose of connecting them to the module inputs.

**Failure to follow these instructions can result in death, serious injury, or equipment damage.**



# TM5SDM8TBFS Safety Module 6DI 2DO 24 Vdc

## What's in This Chapter

TM5SDM8TBFS Presentation ..... 161  
 TM5SDM8TBFS Characteristics ..... 164  
 TM5SDM8TBFS Wiring ..... 169

## TM5SDM8TBFS Presentation

### Main Features

The following table describes the main features of the Safety Digital Mixed module TM5SDM8TBFS:

Main Features	
Number of inputs	6 safety-related digital inputs
Input filter	Configurable input filter, 0...500 ms
Input circuit	Sink
Number of outputs	<ul style="list-style-type: none"> <li>• 6 test (pulse) outputs</li> <li>• 2 safety-related digital FET outputs with current monitoring</li> </ul>
Rated voltage	24 Vdc
Module supply	1 module supply

This equipment has been designed to operate outside of any hazardous location. Only install this equipment in zones known to be free of a hazardous atmosphere.

 <b>DANGER</b>
<p><b>POTENTIAL FOR EXPLOSION</b></p> <p>Install and use this equipment in non-hazardous locations only.</p> <p><b>Failure to follow these instructions will result in death or serious injury.</b></p>

## Ordering Information

The following figure presents the module in combination with the required components:

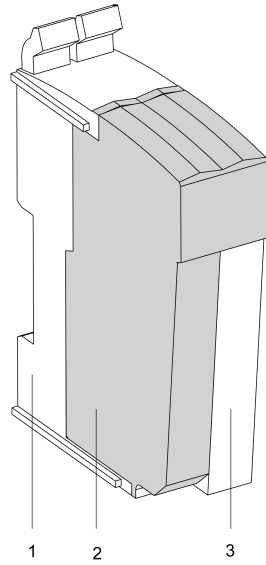

The following table presents the reference of the module:

Number	Reference	Description	Color
2	TM5SDM8TBFS	TM5 Safety Digital Mixed module	red

The following table presents the references for the required components:

Number	Reference	Description	Color
1	TM5ACBM3-FS	TM5 Safety bus base, safety coded, internal I/O supply is interconnected	red
3	TM5ACTB5F-FS	TM5 Safety terminal block, 16-pin, safety coded	red

**NOTE:** A TM5 Safety bus base and a TM5 Safety terminal block are required for operation of the module, and are sold separately. For more information, refer to TM5ACBM3FS Safety bus base, page 232 and TM5ACTB5FFS Safety terminal block, page 243.

## Status LED Indicators

This figure presents the TM5SDM8TBFS status LED indicators:

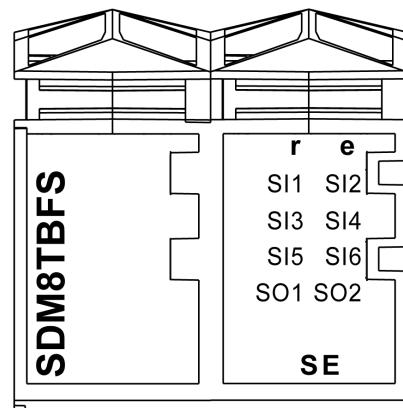



The following tables describe the status LED indicators:

LED indicator	Color	Status	Description
r	off		Module supply not connected.
	green	single flash	reset mode
		double flash	firmware update in progress
		flashing	pre-operational state
		on	RUN state
e	off		No error detected or module supply not connected.
	red	flashing	boot loader mode
		triple flash	firmware update in progress
		on	error detected
r+e	steady red/single green flash		invalid configuration

LED indicator	Color	Status	Description
S11 ... S16	red	on	Indicates either an error has been detected for the corresponding input or that the safety-related input is being used as a non-safety-related input.  <b>NOTE:</b> When there is no connection to the Safety Logic Controller, all channels are steady red.
		flashing	detected error in 2-channel evaluation (synchronous flashing of two affected channels).
	green	on	input set

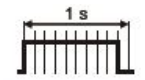
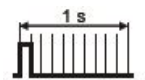
LED indicator	Color	Status	Description
SO1 SO2	red	on	Indicates either an error has been detected for the corresponding output or that the safety-related output is being used as a non-safety-related output.  <b>NOTE:</b> When there is no connection to the Safety Logic Controller, all channels are steady red.
	orange	on	output set

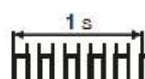
LED indicator	Color	Status	Description
S E	off		RUN state or 24 Vdc supply not present
	red		boot phase or missing TM5 link or non-functioning processor (refer to safety message below)
			pre-operational state
			communication channel is not OK
			firmware for this module is a non-certified pilot version  <b>NOTE:</b> If you observe this indication, you must immediately replace the module, or update its firmware with a certified version. In all cases, contact your Schneider Electric representative.

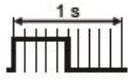
LED indicator	Color	Status	Description
			boot phase, inoperable firmware
		on	Safety-related status is active.

Whenever the **S** and **E** LED indicators are illuminated continuously, this indicates that the module is inoperable. There is also a diagnostic available in the Safety Logic Controller to indicate this state. Replacement of the module must be made immediately. It is your responsibility to ensure all necessary repairs are made promptly to enable proper functionality.

<b>⚠ WARNING</b>
<p><b>LOSS OF SAFETY FUNCTION</b></p> <ul style="list-style-type: none"> <li>• Immediately replace any and all modules that indicate that they are in an inoperable state.</li> <li>• Ensure that the effect on un-repaired equipment is taken into account in your risk assessment.</li> <li>• Make all necessary repairs to equipment before re-starting, or continuing service of, your machine.</li> </ul> <p><b>Failure to follow these instructions can result in death, serious injury, or equipment damage.</b></p>

## TM5SDM8TBFS Characteristics

### Introduction

This section describes the characteristics of the TM5SDM8TBFS module. See also TM5 Environmental Characteristics, page 26.

<b>⚠ DANGER</b>
<p><b>FIRE HAZARD</b></p> <p>Use only the correct wire sizes for the maximum current capacity of the I/O channels and power supplies.</p> <p><b>Failure to follow these instructions will result in death or serious injury.</b></p>

<b>⚠ WARNING</b>
<p><b>UNINTENDED EQUIPMENT OPERATION</b></p> <p>Do not exceed any of the rated values specified in the environmental and electrical characteristics tables.</p> <p><b>Failure to follow these instructions can result in death, serious injury, or equipment damage.</b></p>

### General Characteristics

The following table lists the general characteristics of the TM5SDM8TBFS module:

General characteristics		
Rated power supply voltage		24 Vdc
Status indicators		<ul style="list-style-type: none"> <li>I/O functions per channel</li> <li>operating state</li> <li>module status</li> </ul>
Diagnostics	module run and detected error	indicated by status LED indicator and software status
	inputs	indicated by status LED indicator and software status
	outputs	indicated by status LED indicator and software status
Electrical isolation <sup>1)</sup>	channel - bus	See note.
	channel - channel	no galvanic isolation
TM5 Bus 5 Vdc current draw		50 mA
24 Vdc I/O segment current draw		58.3 mA
Certifications and standards		<ul style="list-style-type: none"> <li>CE</li> <li>cULus</li> <li>KC</li> <li>EN IEC 61508:2010</li> <li>EN IEC 62061:2010</li> <li>EN ISO 13849-1:2008</li> <li>EN IEC 61511:2004</li> <li>EN 50156-1:2004</li> </ul>
Maximum internal cycle time		1 ms
Minimum cycle time		200 µs
Minimum I/O update time		500 µs
Id code for firmware update		48549 dec

**NOTE** <sup>(1)</sup> The isolation of the electronic module is 500 Vac RMS between the electronics power by the TM5 bus and those powered by 24 Vdc I/O power segment connected to the module. In practice, the electronic module is installed in the bus base, and there is a bridge between the TM5 power bus and the 24 Vdc I/O power segment. The two power circuits reference the same functional ground (FE) through specific components designed to reduce effects of electromagnetic interference. These components are rated at 30 Vdc or 60 Vdc. This effectively reduces isolation of the entire system from the 500 Vac RMS.

## Operating Conditions

The following table lists the operating conditions for the TM5SDM8TBFS module:

Operating conditions		
Mounting orientation		horizontal or vertical
Operating temperature	horizontal installation	0...+55 °C (+32...131 °F), for derating refer to following table <sup>1</sup>
	vertical installation	0...+42.5 °C (+32...108.5 °F), for derating refer to following table <sup>1</sup>
Relative humidity		5...95%, non-condensing
Installation at altitudes above sea level:	0 up to 2000 m (0 up to 6561 ft)	no derating for altitude
	> 2000 m (>6561 ft)	reduction of ambient temperature by 0.5 °C per 100 m (0.9 °F per 328 ft)
EN 60529 Protection type		IP20

<sup>1</sup> Derating in relation to operating temperature and mounting orientation

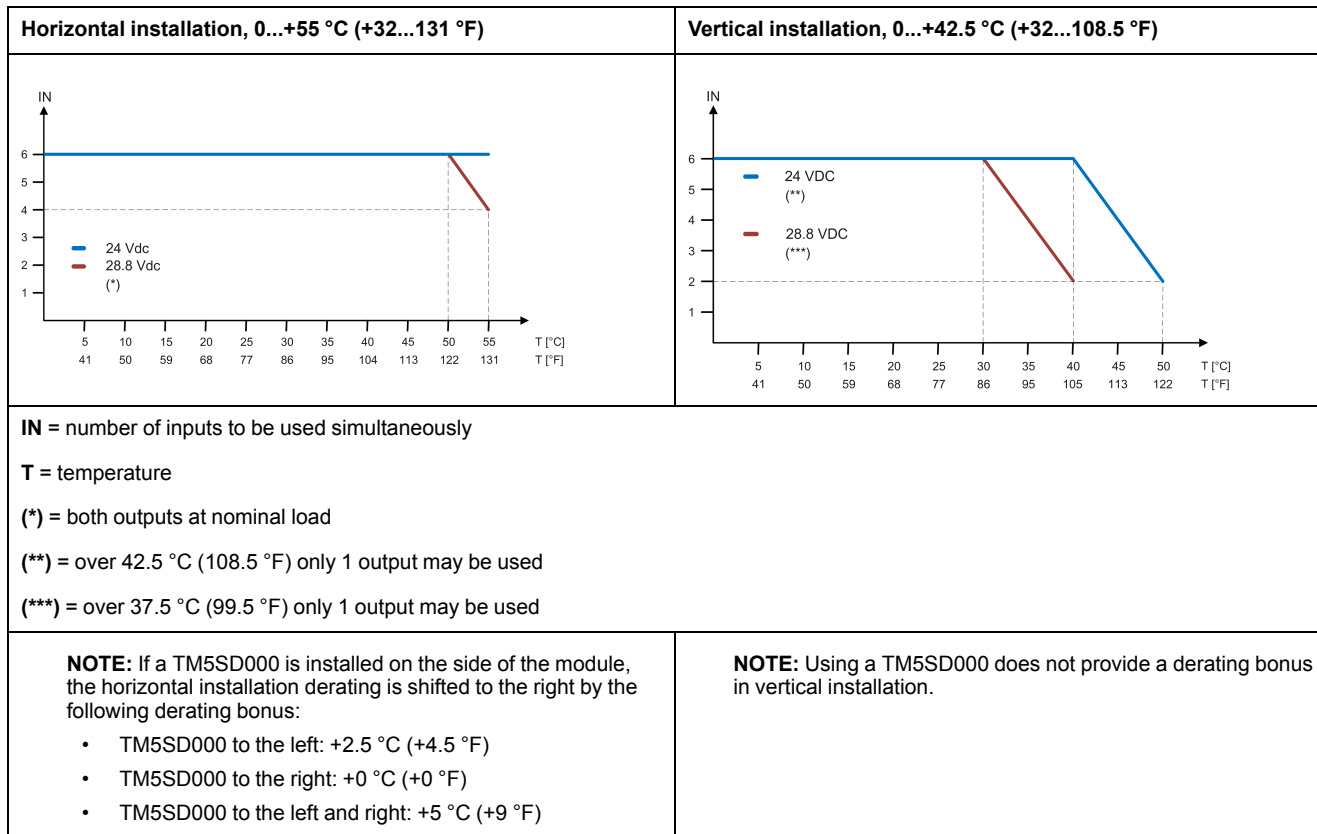

### Storage and Transport Conditions

The following table lists the storage and transport conditions for the TM5SDM8TBFS module:

Storage and transport conditions	
Temperature	-25...+70 °C (-13...+158 °F)
Relative humidity	5...95%, non-condensing

### Module Supply Characteristics

The following table lists the module supply characteristics for the TM5SDM8TBFS module

Module supply characteristics	
Integrated protection	reverse polarity protection
Rated voltage	24 Vdc
Voltage range	20.4...28.8 Vdc

### Safety-Related Digital Inputs Characteristics

The following table lists the safety-related digital input characteristics of the TM5SDM8TBFS module:

Digital input		
Number of input channels	6	
Rated voltage	24 Vdc	
Input filter	hardware	≤150 μs
	software	default: 0 ms, configurable 0...500 ms

Digital input	
Input circuit	sink
Input voltage range	20.4...28.8 Vdc
Input current at 24 Vdc	typical: 2.48 mA
Input resistance	typical: 9.68 kΩ
OFF state (switching threshold low)	<5 Vdc
ON state (switching threshold high)	>15 Vdc
Isolation voltage between channel and bus <sup>1)</sup>	See note.
Error detection time	100 ms

**NOTE** <sup>(1)</sup> The isolation of the electronic module is 500 Vac RMS between the electronics power by the TM5 bus and those powered by 24 Vdc I/O power segment connected to the module. In practice, the electronic module is installed in the bus base, and there is a bridge between the TM5 power bus and the 24 Vdc I/O power segment. The two power circuits reference the same functional ground (FE) through specific components designed to reduce effects of electromagnetic interference. These components are rated at 30 Vdc or 60 Vdc. This effectively reduces isolation of the entire system from the 500 Vac RMS.

### Digital Test (Pulse) Output Characteristics

The following table lists the digital test (pulse) output characteristics of the TM5SDM8TBFS module:

Digital test outputs	
Design	push-pull
Switching voltage	module supply minus residual voltage
Rated output current	20 mA
Total current	120 mA
Output protection	disable individual channels for over-current or short circuit
Short circuit peak current	100 mA
Residual voltage	typical: 2 Vdc
Diagnostics status	output monitoring
Maximum cable length	50 m / 164 ft (shielded)

### Safety-Related Digital FET Outputs Characteristics

The following table lists the safety-related digital FET output characteristics of the TM5SDM8TBFS module:

Digital input	
Number of output channels	2
Design	FET, 2x n switching, type B, output level can be read
Rated voltage	24 Vdc
Rated output current	0.5 A
Total current	1 A
Output protection	<ul style="list-style-type: none"> <li>thermal short circuit cutoff</li> <li>integrated protection of switching inductances</li> </ul>
Braking voltage when switching off inductive loads	typical: 40 Vdc

Digital input	
Diagnostics status	output monitoring
Short circuit peak current	< 12 A
Leakage current when switched off	< 500 µA
Residual voltage	≤ 300 mV at rated current
Switching voltage	module supply minus residual voltage
Test pulse length	> 200 µs
maximum capacitive load	100 nF
Isolation voltage between channel and bus <sup>1)</sup>	See note.
Error detection time	1 s

**NOTE** <sup>(1)</sup> The isolation of the electronic module is 500 Vac RMS between the electronics power by the TM5 bus and those powered by 24 Vdc I/O power segment connected to the module. In practice, the electronic module is installed in the bus base, and there is a bridge between the TM5 power bus and the 24 Vdc I/O power segment. The two power circuits reference the same functional ground (FE) through specific components designed to reduce effects of electromagnetic interference. These components are rated at 30 Vdc or 60 Vdc. This effectively reduces isolation of the entire system from the 500 Vac RMS.

## Safety-Related Characteristics

The following table lists the safety-related characteristics of the TM5SDM8TBFS module:

Criteria	Characteristic value for input channels	Characteristic value in DisableOSSD = No	Characteristic value in DisableOSSD = Yes-ATTENTION
Maximum performance level according to EN ISO 13849-1:2008	PL e		PL d
Category according to EN ISO 13849-1:2008	<ul style="list-style-type: none"> <li>CAT 3 for the use of single input channels.</li> <li>CAT 4 for the use of input channel pairs (for example SI1 and SI2) or more.</li> </ul>	CAT 4	CAT 3
Maximum safety integrity level according to IEC 62061:2010	SIL 3		SIL 2
Maximum safety integrity level according to IEC 61508:2010	SIL 3		SIL 2
Maximum safety integrity level in accordance with EN IEC 61511:2004	SIL 3		SIL 2
PFH	<1*10 <sup>-10</sup>		
PFD	<ul style="list-style-type: none"> <li>&lt;1*10<sup>-5</sup> at a proof test interval of 10 years</li> <li>&lt;2*10<sup>-5</sup> at a proof test interval of 20 years</li> </ul>		
PT	maximum 20 years		
DC	>94% (input used with pair)	>94%	>60%
SFF	>90% (input used with pair)	>90%	>60%
MTTFd	2500 years		
Life time, page 26	20 years		



# TM5SDM8TBFS Wiring

## Pin Assignments / Connection Example

The following figure presents a connection example for the TM5SDM8TBFS:

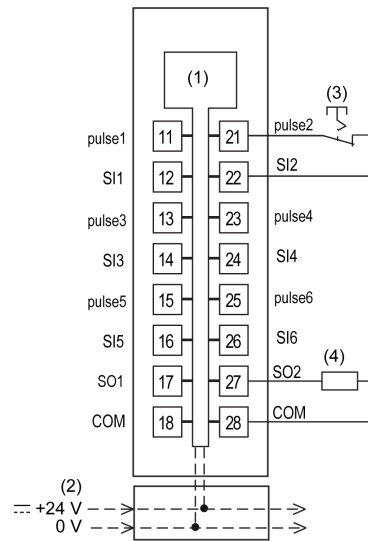

- 1 Internal electronics
- 2 24 Vdc I/O power segment integrated into the bus bases
- 3 2-wire sensor
- 4 Actuator 24 Vdc

<b>⚠ WARNING</b>
<p><b>UNINTENDED EQUIPMENT OPERATION</b></p> <p>Do not connect wires to unused terminals and/or terminals indicated as “No Connection (N.C.)”.</p> <p><b>Failure to follow these instructions can result in death, serious injury, or equipment damage.</b></p>

<b>⚠ WARNING</b>
<p><b>UNINTENDED EQUIPMENT OPERATION</b></p> <p>Use the sensor and actuator power supply only for supplying power to sensors or actuators connected to the module.</p> <p><b>Failure to follow these instructions can result in death, serious injury, or equipment damage.</b></p>

# TM7SDM12DTFS Safety Module 8DI 4DO 24 Vdc

## What's in This Chapter

TM7SDM12DTFS Presentation ..... 170  
 TM7SDM12DTFS Characteristics ..... 174  
 TM7SDM12DTFS Wiring ..... 179

## TM7SDM12DTFS Presentation

### Main Features

The following table describes the main features of the Safety Digital Mixed module TM7SDM12DTFS:

Main Features	
Number of Inputs	8
Input Type	safety-related digital inputs and configurable input filter
Input Circuit	sink
Number of Outputs	<ul style="list-style-type: none"> <li>• 8 test (pulse) outputs</li> <li>• 4 safety-related digital FET outputs</li> </ul>
Rated Voltage	24 Vdc

### **⚠ DANGER**

#### **POTENTIAL FOR EXPLOSION**

- Only use this equipment in non-hazardous locations or in locations that comply either with the Class I, Division 2, Groups A, B, C and D, or with the ATEX Group II, Zone 2 specifications for hazardous locations, depending on your local and/or national regulations.
- Do not substitute components which would impair compliance to the hazardous location specifications of this equipment.
- Do not connect or disconnect equipment unless power has been removed or the location is known to be non-hazardous.

**Failure to follow these instructions will result in death or serious injury.**

## Ordering Information

This figure presents the TM7SDM12DTFS module:

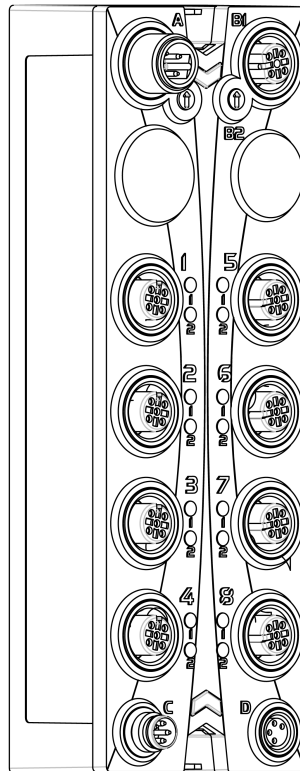

The following table presents the reference of the module:

Model Number	Description	Color
TM7SDM12DTFS	TM7 Safety Digital Mixed module	red

**NOTE:** For more information, refer to:

- TM7 Physical Description, page 35,
- TM7 Block grounding (see PacDrive TM5 / TM7 Flexible System, System Planning and Installation Guide),
- TM7 Installation Guidelines (see Modicon TM7, Digital I/O Blocks, Hardware Guide).

## Status LED Indicators

This figure presents the status LED indicators:

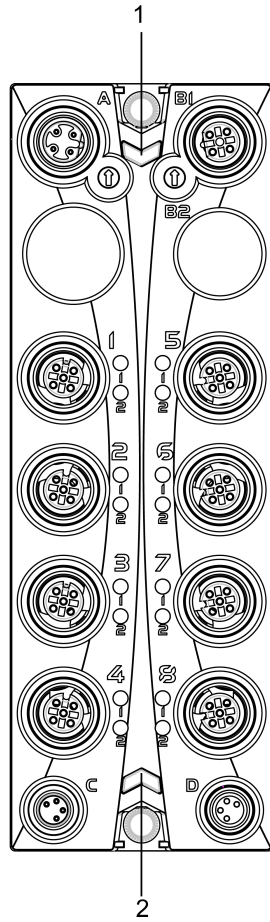

**1** Status LED indicators **r** and **e**: left green **r**, right red **e**





**2** Status LED indicators **S** and **E**: left red **S**, right red **E**

The following tables describe the status LED indicators:

LED indicator	Color	Status	Description
<b>r</b>	off		Module supply not connected.
	green	single flash	reset mode
		double flash	firmware update in progress
		flashing	pre-operational state
	on	RUN state	
<b>e</b>	off		No error detected or module supply not connected.
	red	flashing	boot loader mode
		triple flash	firmware update in progress
	on	error detected	
<b>r+e</b>	steady red/single green flash		invalid configuration

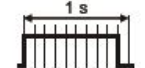
LED indicator	Color	Status	Description
1-1 1-2 2-1 2-2	red	on	Indicates either an error has been detected for the corresponding input or that the safety-related input is being used as a non-safety-related input.  <b>NOTE:</b> When there is no connection to the Safety Logic Controller, all channels are steady red.
5-1 5-2		flashing	detected error in 2-channel evaluation (synchronous flashing of two affected channels).
6-1 6-2	green	on	input set

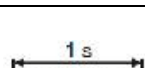
LED indicator	Color	Status	Description
4-1 4-2 8-1 8-2	red	on	Indicates either an error has been detected for the corresponding output or that the safety-related output is being used as a non-safety-related output.  <b>NOTE:</b> When there is no connection to the Safety Logic Controller, all channels are steady red.
		orange	on

LED indicator	Color	Status	Description
S E	off		RUN state or 24 Vdc supply not present
	red		boot phase or missing TM5 link or non-functioning processor (refer to safety message below)
			pre-operational state
			communication channel is not OK
			firmware for this module is a non-certified pilot version  <b>NOTE:</b> If you observe this indication, you must immediately replace the module, or update its firmware with a certified version. In all cases, contact your Schneider Electric representative.
			boot phase, inoperable firmware
	on		Safety-related status is active.

Whenever the **S** and **E** LED indicators are illuminated continuously, this indicates that the module is inoperative. There is also a diagnostic available in the Safety Logic Controller to indicate this state. Replacement of the module must be made immediately. It is your responsibility to ensure all necessary repairs are made promptly to enable proper functionality.

<b>⚠ WARNING</b>
<p><b>LOSS OF SAFETY FUNCTION</b></p> <ul style="list-style-type: none"> <li>• Immediately replace any and all modules that indicate that they are in an inoperable state.</li> <li>• Ensure that the effect on un-repaired equipment is taken into account in your risk assessment.</li> <li>• Make all necessary repairs to equipment before re-starting, or continuing service of, your machine.</li> </ul> <p><b>Failure to follow these instructions can result in death, serious injury, or equipment damage.</b></p>

## TM7SDM12DTFS Characteristics

### Introduction

This section describes the characteristics of the TM7SDM12DTFS module. See also Environmental Characteristics (see PacDrive TM5 / TM7 Flexible System, System Planning and Installation Guide).

<b>⚠ DANGER</b>
<p><b>FIRE HAZARD</b></p> <p>Use only the correct wire sizes for the maximum current capacity of the I/O channels and power supplies.</p> <p><b>Failure to follow these instructions will result in death or serious injury.</b></p>

<b>⚠ WARNING</b>
<p><b>UNINTENDED EQUIPMENT OPERATION</b></p> <p>Do not exceed any of the rated values specified in the environmental and electrical characteristics tables.</p> <p><b>Failure to follow these instructions can result in death, serious injury, or equipment damage.</b></p>

### General Characteristics

The following table lists the general characteristics of the TM7SDM12DTFS module:

General Characteristics		
Rated power supply voltage		24 Vdc
Status indicators		<ul style="list-style-type: none"> <li>• I/O functions per channel</li> <li>• operating state</li> <li>• module status</li> </ul>
Diagnostics	module run and detected error	indicated by status LED indicator and software status
	inputs	indicated by status LED indicator
	outputs	indicated by status LED indicator and software status (detected output error status)
Electrical isolation <sup>1)</sup>	channel - bus	See note.
	channel - channel	no galvanic isolation
TM5 Bus 5 Vdc current draw		160 mA

General Characteristics		
24 Vdc I/O segment current draw		75 mA
Connection type	inputs / outputs	M12, A-coded
	module supply	M8, 4-pin
	TM5 link	M12, B-coded
Certifications and standards		<ul style="list-style-type: none"> <li>• CE</li> <li>• UL508 (ULus)</li> <li>• cCSAus Hazardous Locations Class I, Division 2</li> </ul> <p><b>NOTE:</b> Refer to <a href="http://www.se.com">www.se.com</a> for the latest information regarding certifications.</p>
Maximum internal cycle time		1 ms
Minimum cycle time		200 µs
Minimum I/O update time		500 µs
Minimum safety-related response time		6 ms
Id code for firmware update		42918 dec

**NOTE** <sup>(1)</sup> The isolation of the electronic module is 500 Vac RMS between the electronics power by the TM5 to TM7 bus and those powered by 24 Vdc I/O power segment connected to the module. In practice, the electronic module is installed in the bus base, and there is a bridge between the TM5 power bus and the 24 Vdc I/O power segment. The two power circuits reference the same functional ground (FE) through specific components designed to reduce effects of electromagnetic interference. These components are rated at 30 Vdc or 60 Vdc. This effectively reduces isolation of the entire system from the 500 Vac RMS.

## Operating Conditions

The following table lists the operating conditions for the TM7SDM12DTFS module:

Operating Conditions		
Mounting orientation		horizontal or vertical
Operating temperature		0...60°C (+32...140°F)
Relative humidity		5...95%, non-condensing
Installation at altitudes above sea level:	0...2000 m (0...6561 ft)	no derating for altitude
	> 2000 m (>6561 ft)	reduction of ambient temperature by 0.5 °C per 100 m (0.9 °F per 328 ft)
EN 60529 protection		IP67

## Storage and Transport Conditions

The following table lists the storage and transport conditions for the TM7SDM12DTFS module:

Storage and Transport Conditions	
Temperature	-25...+85 °C (-13...+185 °F)
Relative humidity	5...95%

## Mechanical Characteristics

The following table lists the mechanical characteristics for the TM7SDM12DTFS module:

Mechanical characteristics		
Dimensions (W x H x D)		53 x 155 x 42 mm (2,086 x 6,10 x 1,65 in.)
Weight		350 g (12.32 oz.)
Torque for connections	M8	Maximum 0.4 Nm (0.29 lbf ft)
	M12	Maximum 0.6 Nm (0.44 lbf ft)

## Module Supply Characteristics

The following table lists the module supply characteristics for the TM7SDM12DTFS module

Module supply characteristics	
Integrated protection	reverse polarity protection
Rated voltage	24 Vdc
Voltage range	18...30 Vdc

## Digital Input Characteristics

The following table lists the digital input characteristics of the TM7SDM12DTFS module:

Digital Input		
Number of input channels		8
Rated voltage		24 Vdc
Input filter	hardware	≤ 150 μs
	software	configuration between 0 and 500 ms
Input circuit		sink
Input voltage		20.4...28.8 Vdc
Input current at 24 Vdc		typical: 3.3 mA
Input resistance		typical: 7.3 kΩ
Switching threshold	low	<5 Vdc
	high	>15 Vdc
Isolation voltage between channel and bus <sup>1)</sup>		See note.
Error detection time		200 ms

**NOTE** <sup>(1)</sup> The isolation of the electronic module is 500 Vac RMS between the electronics power by the TM5 to TM7 bus and those powered by 24 Vdc I/O power segment connected to the module. In practice, the electronic module is installed in the bus base, and there is a bridge between the TM5 power bus and the 24 Vdc I/O power segment. The two power circuits reference the same functional ground (FE) through specific components designed to reduce effects of electromagnetic interference. These components are rated at 30 Vdc or 60 Vdc. This effectively reduces isolation of the entire system from the 500 Vac RMS.

## Digital Output Characteristics

The following table lists the digital test (pulse) output characteristics of the TM7SDM12DTFS module:

Digital Outputs	
Rated voltage	24 Vdc
Rated output current	2 A



Digital Outputs	
Total current	5 A
Output protection	<ul style="list-style-type: none"> <li>• disable individual channels for over-current or short circuit</li> <li>• integrated protection of switching inductances</li> </ul>
Design	<ul style="list-style-type: none"> <li>• FET, 2x n switching, type B</li> <li>• output level can be read</li> </ul>
Switching voltage	modules supply minus residual voltage
Diagnostics status	Output monitoring
Leakage current when switched off	100 µA
Residual voltage	≤ 700 mVdc
Short circuit peak current	typical: 30 A, < 1 ms at 25°C (77°F)
Peak output current	2.5 A (effective current ≤ 2.0 A)
Test pulse length	Maximum 1 ms
Re-arming after overload or short circuit detection	Set <code>ReleaseOutput0x</code> from 0 to 1. Then, after a positive edge on the <code>SafeDigitalOutput0x</code> channel, the output goes high.
Braking voltage when switching off inductive loads	typical: 50 Vdc
Maximum capacitive load	100 nF
Isolation voltage between channel and bus <sup>1)</sup>	See note.
Error detection time	1 s
Minimum load	12 mA

**NOTE** <sup>(1)</sup> The isolation of the electronic module is 500 Vac RMS between the electronics power by the TM5 to TM7 bus and those powered by 24 Vdc I/O power segment connected to the module. In practice, the electronic module is installed in the bus base, and there is a bridge between the TM5 power bus and the 24 Vdc I/O power segment. The two power circuits reference the same functional ground (FE) through specific components designed to reduce effects of electromagnetic interference. These components are rated at 30 Vdc or 60 Vdc. This effectively reduces isolation of the entire system from the 500 Vac RMS.

### Digital Test (Pulse) Output Characteristics

The following table lists the digital test (pulse) output characteristics of the TM7SDM12DTFS module:

Digital Test Output	
Rated voltage	24 Vdc
Design	Push-Pull
Switching voltage	<ul style="list-style-type: none"> <li>• 20.4...28.8 Vdc</li> <li>• equal to module supply minus residual voltage</li> </ul>
Rated output current	50 mA
Total current	400 mA
Output protection	<ul style="list-style-type: none"> <li>• disable individual channels if short-circuit of supply occurs</li> <li>• thermal limit determined by PTC</li> </ul>
Short circuit current	typical: 30 mA
Short circuit peak current	typical: 7 A for 1 ms
Diagnostics status	Output monitoring

Digital Test Output	
Residual voltage	typical: 0.2 Vdc
Maximum cable length	50 m / 164 ft (shielded)

### Safety-Related Characteristics

The following table lists the safety-related characteristics of the TM7SDM12DTFS module:

Criteria	Characteristics	
	Safety-related digital input	Safety-related digital output
Maximum performance level according to EN ISO 13849	PL e	
Category according to EN ISO 13849	<ul style="list-style-type: none"> <li>CAT 3 when using individual input channels</li> <li>CAT 4 when using input channel pairs (for example SI1 &amp; SI2) or more</li> </ul>	CAT 4
Maximum safety integrity level according to IEC 62061	SIL 3	
Maximum safety integrity level according to IEC 61508	SIL 3	
PFH	< 1*10 <sup>-10</sup>	
PFD	<ul style="list-style-type: none"> <li>&lt; 1*10<sup>-5</sup> at a proof test interval of 10 years</li> <li>&lt; 2*10<sup>-5</sup> at a proof test interval of 20 years</li> </ul>	
PT	Maximum 20 years	
DC	>94% (input used with pair)	>94% (DisableOSSD=No) >60% (DisableOSSD=Yes-ATTENTION)
SFF	>90% (input used with pair)	>90% (DisableOSSD=No) >60% (DisableOSSD=Yes-ATTENTION)
MTTFd	2500 years	
Life time, page 26	20 years	

# TM7SDM12DTFS Wiring

## Connection Elements

The following figure presents the connection elements for the TM7SDM12DTFS:

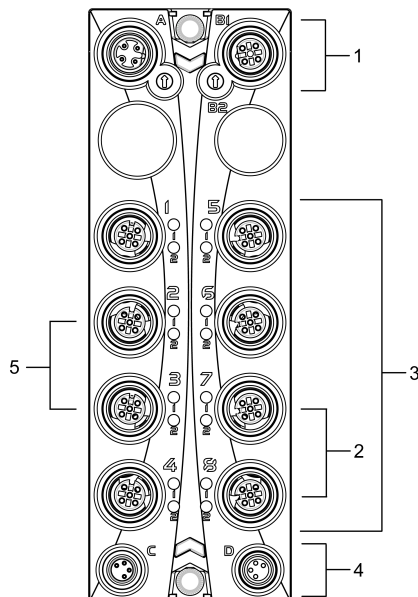

Number	Meaning
1	<ul style="list-style-type: none"> <li>• TM5 link</li> <li>• 2xM12 (4-pin)</li> <li>• connector A: input</li> <li>• connector B1: output</li> </ul>
2	SO4 is available on connectors 7 and 8 (physical connection)
3	Digital I/O 8 x M12 (5-pin)
4	<ul style="list-style-type: none"> <li>• Module supply 24 Vdc</li> <li>• 2 x M8 (4-pin)</li> <li>• connector C: supply feed</li> <li>• connector D: routing</li> </ul>
5	SI4 is available on connectors 2 and 3 (physical connection)

## Pin Assignments

The pin assignments of the power and communication connectors (A, B, C and D) are provided in the TM7 Physical Description, page 36.

The following figure presents the pin assignment for the TM7SDM12DTFS:

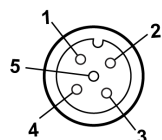

- 1 Test (pulse) x (inputs) or COM (outputs)
- 2 SI x (safety-related inputs) or SO x (safety-related outputs)
- 3 COM
- 4 SI y (safety-related inputs) or SO y (safety-related outputs)
- 5 Test (pulse) y (inputs) or COM (outputs)

The following table describes the pin assignments for the inputs of TM7SDM12DTFS (N.C. = No Connection):

Connector socket	Pin1	Pin2	Pin3	Pin4	Pin5
1 (IN)	Test (pulse) 1	SI 1	COM	SI 2	Test (pulse) 2
2 (IN)	Test (pulse) 3	SI 3	COM	SI 4	Test (pulse) 4
3 (IN)	N.C.	N.C.	COM	SI 4	Test (pulse) 4
5 (IN)	Test (pulse) 5	SI 5	COM	SI 6	Test (pulse) 6
6 (IN)	Test (pulse) 7	SI 7	COM	SI 8	Test (pulse) 8

The following table describes the pin assignments for the outputs of TM7SDM12DTFS (N.C. = No Connection):

Connector socket	Pin1	Pin2	Pin3	Pin4	Pin5
4 (OUT)	COM	SO 1	COM	SO 2	COM
7 (OUT)	COM	N.C.	COM	SO 4	COM
8 (OUT)	COM	SO 3	COM	SO 4	COM

## ⚠ WARNING

### UNINTENDED EQUIPMENT OPERATION

Do not connect wires to unused terminals and/or terminals indicated as "No Connection (N.C.)".

**Failure to follow these instructions can result in death, serious injury, or equipment damage.**

## ⚠ WARNING

### UNINTENDED EQUIPMENT OPERATION

Only use the test (pulse) outputs for the intended purpose of connecting them to the module inputs.

**Failure to follow these instructions can result in death, serious injury, or equipment damage.**

**NOTE:** Cross-circuits between the two channels of a connector cannot be ruled out according to ISO 13849-1. This is why shared error handling, page 42 is implemented for both channels of a connector. This means that both channels are switched off as soon as an error has been detected on one channel.

Detected errors are acknowledged in a similar way. As soon as a detected channel error has been acknowledged, the error state on the other channel of the same connector is also acknowledged.

However, the restart inhibit is separately active for each channel to help prevent unintentional enabling of a channel.

**NOTE:** SI 4 is provided on both connectors 2 and 3 for ease of wiring. This enables SI 4 to be used with one-channel sensors as well as two-channel sensors. Two sensors must not be connected to SI 4 in connector 2 and SI 4 in connector 3, as this would cause a parallel connection of two sensors on one input channel.

**▲ WARNING****PARALLEL CONNECTION ON ONE INPUT CHANNEL**

Do not connect independent inputs to SI 4 in connector 2 and SI 4 in connector 3.

**Failure to follow these instructions can result in death, serious injury, or equipment damage.**

**NOTE:** SO 4 is provided both on the connectors 7 and 8 to make wiring easier. This makes it possible to use SO 4 for one-channel actuators as well as for two-channel actuators.

**▲ WARNING****IP67 NON-CONFORMANCE**

- Properly fit all connectors with cables or sealing plugs and tighten for IP67 conformance according to the torque values as specified in this document.
- Do not connect or disconnect cables or sealing plugs in the presence of water or moisture.

**Failure to follow these instructions can result in death, serious injury, or equipment damage.**

# TM5 Safety Analog Input Modules

## What's in This Part

TM5SAI4AFS Safety Module 2x2AI 4-20mA 24 Bits .....	183
TM5STI4ATCFS Safety Module 2x2AI Thermocouple J/K/N/S/R/C/T .....	193

# TM5SAI4AFS Safety Module 2x2AI 4-20mA 24 Bits

## What's in This Chapter

TM5SAI4AFS Presentation ..... 183  
 TM5SAI4AFS Characteristics ..... 186  
 TM5SAI4AFS Wiring ..... 190

## TM5SAI4AFS Presentation

### Main Features

The following table describes the main features of the Safety Analog Input module TM5SAI4AFS:

Main Features	
Number of inputs	2 redundant safety-related analog inputs
Input filter	configurable input filter and switching threshold
Input range	<ul style="list-style-type: none"> <li>4...20 mA (valid measurement range)</li> <li>0.5...25 mA (input range <i>HW_LIMIT_MIN</i>, <i>HW_LIMIT_MAX</i>)</li> </ul>
Digital converter resolution	24 bits

This equipment has been designed to operate outside of any hazardous location. Only install this equipment in zones known to be free of a hazardous atmosphere.

**⚠ DANGER**

**POTENTIAL FOR EXPLOSION**

Install and use this equipment in non-hazardous locations only.

**Failure to follow these instructions will result in death or serious injury.**

### Ordering Information

The following figure presents the module in combination with the required components:

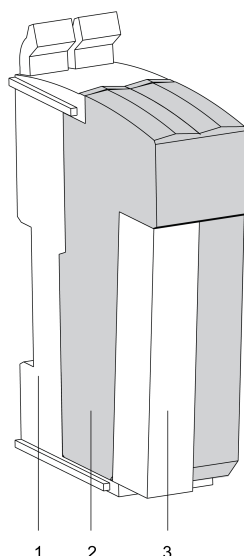

The following table presents the reference of the module:

Number	Reference	Description	Color
2	TM5SAI4AFS	TM5 Safety Analog Input module	red

The following table presents the references for the required components:

Number	Reference	Description	Color
1	TM5ACBM3-FS	TM5 Safety bus base, safety coded, internal I/O supply is interconnected	red
3	TM5ACTB5F-FS	TM5 Safety terminal block, 16-pin, safety coded	red

**NOTE:** A TM5 Safety bus base and a TM5 Safety terminal block are required for operation of the module, and are sold separately. For more information, refer to TM5ACBM3FS Safety bus base, page 232 and TM5ACTB5FFS Safety terminal block, page 243.

### Status LED Indicators

This figure presents the TM5SAI4AFS status LED indicators:

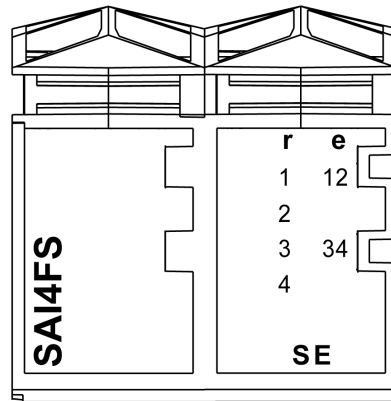



The following tables describe the status LED indicators:

LED indicator	Color	Status	Description
r	off		Module supply not connected.
	green	single flash	reset mode
		double flash	firmware update in progress
		flashing	pre-operational state
		on	RUN state
e	off		No error detected or module supply not connected.
	red	flashing	boot loader mode
		triple flash	firmware update in progress
		on	error detected
r+e	steady red/single green flash		invalid configuration

LED indicator	Color	Status	Description
1	off		channel not used
2	red	on	Indicates either an error has been detected for the corresponding input or that the safety-related input is being used as a non-safety-related input.
3			
4			

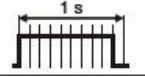
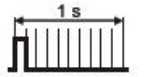

LED indicator	Color	Status	Description
			<b>NOTE:</b> When there is no connection to the Safety Logic Controller, all channels are steady red.
		flashing	open circuit on corresponding channel
	green	on	channel being used and signal OK
		flashing	channel outside of the limits configured in EcoStruxure Machine Expert - Safety
12, 34	off		signal on channel pair not OK
	red	on	Indicates a detected error.
	green	on	signal on channel pair OK

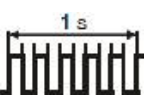
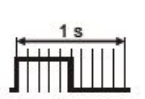
LED indicator	Color	Status	Description
S E	off		RUN state or 24 Vdc supply not present
	red		boot phase or missing TM5 link or non-functioning processor (refer to safety message below)
			pre-operational state
			communication channel is not OK
			firmware for this module is a non-certified pilot version <b>NOTE:</b> If you observe this indication, you must immediately replace the module, or update its firmware with a certified version. In all cases, contact your Schneider Electric representative.
			boot phase, inoperable firmware
	on		Safety-related status is active.

Whenever the **S** and **E** LED indicators are illuminated continuously, this indicates that the module is inoperable. There is also a diagnostic available in the Safety Logic Controller to indicate this state. Replacement of the module must be made immediately. It is your responsibility to ensure all necessary repairs are made promptly to enable proper functionality.

<b>⚠ WARNING</b>
<p><b>LOSS OF SAFETY FUNCTION</b></p> <ul style="list-style-type: none"> <li>• Immediately replace any and all modules that indicate that they are in an inoperable state.</li> <li>• Ensure that the effect on un-repaired equipment is taken into account in your risk assessment.</li> <li>• Make all necessary repairs to equipment before re-starting, or continuing service of, your machine.</li> </ul> <p><b>Failure to follow these instructions can result in death, serious injury, or equipment damage.</b></p>

# TM5SAI4AFS Characteristics

## Introduction

This section describes the characteristics of the TM5SAI4AFS module. See also TM5 Environmental Characteristics, page 26.

### **⚠ DANGER**

#### **FIRE HAZARD**

Use only the correct wire sizes for the maximum current capacity of the I/O channels and power supplies.

**Failure to follow these instructions will result in death or serious injury.**

### **⚠ WARNING**

#### **UNINTENDED EQUIPMENT OPERATION**

Do not exceed any of the rated values specified in the environmental and electrical characteristics tables.

**Failure to follow these instructions can result in death, serious injury, or equipment damage.**

## General Characteristics

The following table lists the general characteristics of the TM5SAI4AFS module:

<b>General characteristics</b>		
Rated power supply voltage		24 Vdc
Status indicators		<ul style="list-style-type: none"> <li>I/O functions per channel</li> <li>operating state</li> <li>module status</li> </ul>
Diagnostics	module run and detected error	indicated by status LED indicator and software status
	inputs	indicated by status LED indicator and software status
Electrical isolation <sup>1)</sup>	channel - bus	See note.
	channel - channel	See note.
	channel pair - channel pair	See note.
TM5 Bus 5 Vdc current draw		50 mA
24 Vdc I/O segment current draw		70.8 mA
Certifications and standards		<ul style="list-style-type: none"> <li>CE</li> <li>cULus</li> <li>KC</li> <li>EN IEC 61508:2010</li> <li>EN IEC 62061:2010</li> <li>EN ISO 13849-1:2008</li> <li>EN IEC 61511:2004</li> <li>EN 50156-1:2004</li> </ul>
Maximum internal cycle time		2000 $\mu$ s
Minimum cycle time		200 $\mu$ s
Minimum I/O update time		500 $\mu$ s
Id code for firmware update		47285 dec

**NOTE** <sup>(1)</sup> The isolation of the electronic module is 500 Vac RMS between the electronics power by the TM5 bus and those powered by 24 Vdc I/O power segment connected to the module. In practice, the electronic module is installed in the bus base, and there is a bridge between the TM5 power bus and the 24 Vdc I/O power segment. The two power circuits reference the same functional ground (FE) through specific components designed to reduce effects of electromagnetic interference. These components are rated at 30 Vdc or 60 Vdc. This effectively reduces isolation of the entire system from the 500 Vac RMS.

## Operating Conditions

The following table lists the operating conditions for the TM5SAI4AFS module:

Operating conditions		
Mounting orientation		horizontal or vertical
Operating temperature	horizontal installation	0...+55 °C (+32...131 °F), for derating refer to following table <sup>1</sup>
	vertical installation	0...+40 °C (+32...104 °F), for derating refer to following table <sup>1</sup>
Relative humidity		5...95%, non-condensing
Installation at altitudes above sea level:	0 up to 2000 m (0 up to 6561 ft)	no derating for altitude
	> 2000 m (>6561 ft)	reduction of ambient temperature by 0.5 °C per 100 m (0.9 °F per 328 ft)
EN 60529 Protection type		IP20

<sup>1</sup> Derating in relation to operating temperature and mounting orientation:

Mounting and temperature	Number of usable signal pairs
Horizontal mounting orientation up to 50 °C (122 °F)	2
Horizontal mounting orientation up to 55 °C (131 °F)	1, with addition of a TM5SD000, see safety message below.
Vertical mounting orientation up to 35 °C (95 °F)	2
Vertical mounting orientation from 35...40 °C (95...104 °F)	1, with addition of a TM5SD000, see safety message below.

## **NOTICE**

### **OVERHEATING**

You must insert a TM5SD000 next to the TM5SAI4AFS module (right or left) beginning at 50 °C (122 °F) for horizontal installations or 35 °C (95 °F) for vertical installations.

**Failure to follow these instructions can result in equipment damage.**

## Storage and Transport Conditions

The following table lists the storage and transport conditions for the TM5SAI4AFS module:

Storage and transport conditions	
Temperature	-25...+70 °C (-13...+158 °F)
Relative humidity	5...95%, non-condensing

## Sensor Supply Characteristics

The following table lists the sensor supply characteristics for the TM5SAI4AFS module

Sensor supply characteristics		
Rated voltage		29 Vdc $\pm$ 5%
Rated output current		maximum 60 mA per channel
Short circuit protection		yes
Electrical isolation <sup>1)</sup>	sensor supply - channel	no
	sensor supply - sensor supply	See note.

**NOTE** <sup>(1)</sup> The isolation of the electronic module is 500 Vac RMS between the electronics power by the TM5 bus and those powered by 24 Vdc I/O power segment connected to the module. In practice, the electronic module is installed in the bus base, and there is a bridge between the TM5 power bus and the 24 Vdc I/O power segment. The two power circuits reference the same functional ground (FE) through specific components designed to reduce effects of electromagnetic interference. These components are rated at 30 Vdc or 60 Vdc. This effectively reduces isolation of the entire system from the 500 Vac RMS.

## Safety-Related Analog Inputs Characteristics

The following table lists the safety-related analog input characteristics of the TM5SAI4AFS module:

Analog input		
Number of input channels		2 redundant
Input current range		<ul style="list-style-type: none"> <li>• 4...20 mA (valid measurement range)</li> <li>• 0.5...25 mA (input range)</li> </ul>
Input type		Differential input
Digital converter resolution		24-bit
Conversion time		refer to following table
Output format		double word integer value
Load impedance		230 $\Omega$ to 420 $\Omega$
Input protection		protection against external supply voltages and overcurrent
Open line detection		yes, using software
Permitted input signal		maximum 40 mA
Input signal tolerances	signal interference	maximum 0.5 % of measured value
	signal increase	maximum 220 $\mu$ A/ms
	signal frequency	maximum 100 Hz
Conversion procedure		sigma delta
Maximum detected error at 25 °C (77 °F)	Gain: 4...20 mA	<0.08 % <sup>2)</sup>
	Offset: 4...20 mA	<0.03 % <sup>3)</sup>
Common-mode rejection	DC	70 dB
	50 Hz	70 dB
Common-mode range		between the inputs $\pm$ 50 V
Non-linearity		0.003 %
Resolution		1 $\mu$ A/LSB

Analog input		
Overload detection		yes, using software
Maximum gain drift: 4...20 mA		<0.005 %/1 °C (1.8 °F) <sup>2)</sup>
Maximum offset drift: 4...20 mA		<0.003 %/1 °C (1.8 °F) <sup>3)</sup>
Isolation <sup>1)</sup>	channel and bus	See note.
	to ground	See note.
	channel pair and channel pair	See note.
Safety-related accuracy per channel	CAT 3	0.75 % <sup>3)</sup>
	CAT 4	2.00 % <sup>3)</sup>
Input filter	hardware	1 first-order low pass / cutoff frequency 500 Hz
	software	Sinc <sup>3)</sup> filter
Filter time		configurable: 1; 2; 10; 16.7; 20; 33.3; 40; 66.7 ms
<p><b>NOTE</b> <sup>(1)</sup> The isolation of the electronic module is 500 Vac RMS between the electronics power by the TM5 bus and those powered by 24 Vdc I/O power segment connected to the module. In practice, the electronic module is installed in the bus base, and there is a bridge between the TM5 power bus and the 24 Vdc I/O power segment. The two power circuits reference the same functional ground (FE) through specific components designed to reduce effects of electromagnetic interference. These components are rated at 30 Vdc or 60 Vdc. This effectively reduces isolation of the entire system from the 500 Vac RMS.</p> <p><sup>2)</sup> = based on the current measured value</p> <p><sup>3)</sup> = based on the 16 mA measurement range</p>		

The following table lists the signal processing time of the module resulting from the set input filter time value (update interval).

<b>⚠ WARNING</b>
<b>UNINTENDED EQUIPMENT OPERATION</b>
Verify that the signal processing time of the input module is included correctly in the safety response time calculations in EcoStruxure Machine Expert - Safety.
<b>Failure to follow these instructions can result in death, serious injury, or equipment damage.</b>

Configured filter value	Maximum signal processing time of the module
1 ms	17 ms
2 ms	19 ms
10 ms	35 ms
16.7 ms	50 ms
20 ms	55 ms
33.3 ms	82 ms
40 ms	95 ms
66.7 ms	122 ms

### Safety-Related Characteristics

**NOTE:** The following safety-related characteristics only apply when using input channel pairs (for example, SAI-1 together with SAI-2 or SAI-3 with SAI-4).

Criteria	Characteristic value for input channel pairs
Maximum performance level according to EN ISO 13849-1-2008	PL e
Category according to EN ISO 13849-1-2008	CAT 4
Maximum safety integrity level according to IEC 62061:2010	SIL 3
Maximum safety integrity level according to IEC 61508:2010	SIL 3
Maximum safety integrity level in accordance with EN IEC 61511:2004	SIL 3
PFH	$<1 \cdot 10^{-9}$
PFD	<ul style="list-style-type: none"> <li><math>&lt;5 \cdot 10^{-5}</math> at a proof test interval of 10 years</li> <li><math>&lt;1 \cdot 10^{-5}</math> at a proof test interval of 20 years</li> </ul>
PT	maximum 20 years
DC	>94%
SFF	>90%
MTTFd	2200 years
Life time, page 26	20 years

## TM5SAI4AFS Wiring

### Pin Assignments / Connection Example

The following channel pair application is sufficient to achieve maximum PL e (EN ISO 13849-1:2008), maximum SIL 3 (EN IEC 62061:2010), maximum SIL 3 (EN IEC 61508:2010), and maximum SIL 3 (EN IEC 61511:2004).

TM5SAI4AFS 2-wire connection, 2x SIL 2

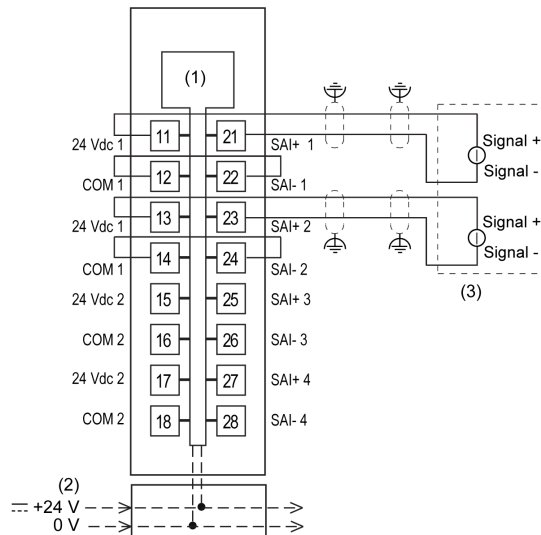

1 Internal electronics

2 24 Vdc I/O power segment integrated into the bus bases

3 2-channel sensor, module sensor power supplied

TM5SAI4AFS 4-wire connection, 2x SIL 2

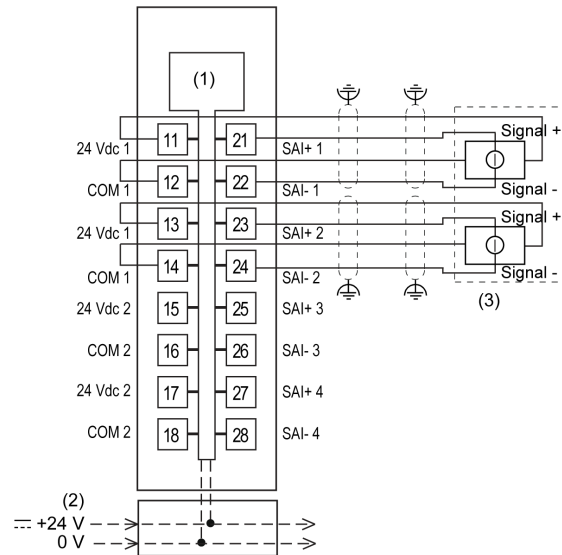

1 Internal electronics

2 24 Vdc I/O power segment integrated into the bus bases

3 2-channel sensor, module sensor power supplied

TM5SAI4AFS 2-wire connection, 1x SIL 2

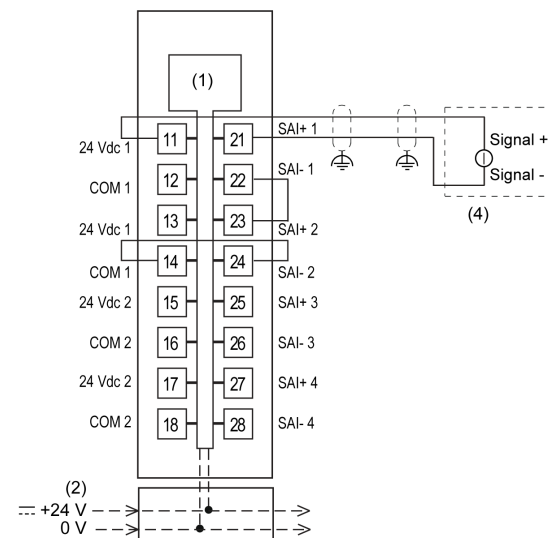

1 Internal electronics

2 24 Vdc I/O power segment integrated into the bus bases

3 2-channel sensor, module sensor power supplied

TM5SAI4AFS 4-wire connection, 1x SIL 2

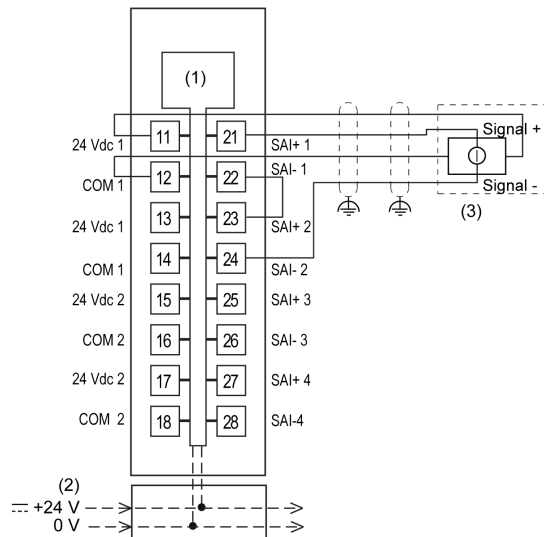

1 Internal electronics

2 24 Vdc I/O power segment integrated into the bus bases

3 2-channel sensor, module sensor power supplied

Use shielded, properly grounded cables for all analog and high-speed inputs or outputs and communication connections. If you do not use shielded cable for these connections, electromagnetic interference can cause signal degradation. Degraded signals can cause the controller or attached modules and equipment to perform in an unintended manner.

**⚠ WARNING**

**UNINTENDED EQUIPMENT OPERATION**

- Use shielded cables for all fast I/O, analog I/O, and communication signals.
- Ground cable shields for all fast I/O, analog I/O, and communication signals at a single point<sup>1</sup>.
- Route communications and I/O cables separately from power cables.

**Failure to follow these instructions can result in death, serious injury, or equipment damage.**

<sup>1</sup>Multipoint grounding is permissible (and in some cases inevitable) if connections are made to an equipotential ground plane dimensioned to help avoid cable shield damage in the event of power system short-circuit currents.

**⚠ WARNING**

**UNINTENDED EQUIPMENT OPERATION**

Do not connect wires to unused terminals and/or terminals indicated as “No Connection (N.C.)”.

**Failure to follow these instructions can result in death, serious injury, or equipment damage.**

**⚠ WARNING**

**UNINTENDED EQUIPMENT OPERATION**

Use the sensor and actuator power supply only for supplying power to sensors or actuators connected to the module.

**Failure to follow these instructions can result in death, serious injury, or equipment damage.**



# TM5STI4ATCFS Safety Module 2x2AI Thermocouple J/K/N/S/R/C/T

## What's in This Chapter

TM5STI4ATCFS Presentation ..... 193  
 TM5STI4ATCFS Characteristics ..... 196  
 TM5STI4ATCFS Wiring ..... 201

## TM5STI4ATCFS Presentation

### Main Features

The following table describes the main features of the Safety Analog Input module TM5STI4ATCFS:

Main Features	
Number of inputs	2 redundant safety-related analog inputs for thermocouples  2 safety-related inputs for PT100/PT1000 Temperature compensation
Input sensor type	J, K, N, S, R, C, T  thermocouple sensors
Input range	<ul style="list-style-type: none"> <li>• Type J, Fe-CuNi: -210...1200 °C (-346...2192 °F)</li> <li>• Type K, NiCr-Ni: -270...1372 °C (-454...2501.6 °F)</li> <li>• Type N, NiCrSi-NiSi: -270...1300 °C (-454...2372 °F)</li> <li>• Type S, PtRh10-Pt: -50...1768 °C (-58...3214.4 °F)</li> <li>• Type R, PtRh13-Pt: -50...1768 °C (-25...3214.4 °F)</li> <li>• Type C, WRe5-WRe26: 0...2320 °C (32...4208 °F)</li> <li>• Type T, Cu-CuNi: -270...400 °C (-454...752 °F)</li> </ul> Sensor specification in accordance with EN IEC 60584-1:2010.
Input filter	configurable input filter and switching threshold
Input range	-65...+65 mV (voltage measurement range <i>HW_LIMIT_MIN</i> , <i>HW_LIMIT_MAX</i> )
Terminal temperature compensation	2 non-redundant safety-related analog inputs for PT100/PT1000 measurement
Digital converter resolution	24 bits

This equipment has been designed to operate outside of any hazardous location. Only install this equipment in zones known to be free of a hazardous atmosphere.

**⚠ DANGER**

**POTENTIAL FOR EXPLOSION**

Install and use this equipment in non-hazardous locations only.

**Failure to follow these instructions will result in death or serious injury.**

The thermocouple modules are configured as a whole for the same type of thermocouple sensor. You cannot mix thermocouple sensor types on the same module, otherwise the temperature readings will not be correct.

**⚠ WARNING****UNINTENDED EQUIPMENT OPERATION**

- Only connect thermocouple sensors of the same type to the temperature module.
- Configure the module for the correct type of thermocouple.

**Failure to follow these instructions can result in death, serious injury, or equipment damage.**

**Ordering Information**

The following figure presents the module in combination with the required components:

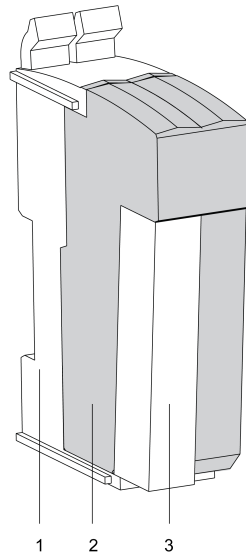

The following table presents the reference of the module:

Number	Reference	Description	Color
2	TM5STI4ATCFS	TM5 Safety Analog Input module	red

The following table presents the references for the required components:

Number	Reference	Description	Color
1	TM5ACBM3FS	TM5 Safety bus base, safety coded, internal I/O supply is interconnected	red
3	TM5ACTB5EFS	TM5 Safety terminal block, 16-pin, safety coded, 2x PT1000 integrated for terminal temperature compensation	red
	TM5ACTB5FFS	TM5 Safety terminal block, 16-pin, safety coded	red

**NOTE:** A TM5 Safety bus base and a TM5 Safety terminal block are required for operation of the module, and are sold separately. For more information, refer to TM5ACBM3FS Safety bus base, page 232 and TM5ACTB5EFS Safety terminal block, page 241/TM5ACTB5FFS Safety terminal block, page 243.

## Status LED Indicators

This figure presents the TM5STI4ATCFS status LED indicators:

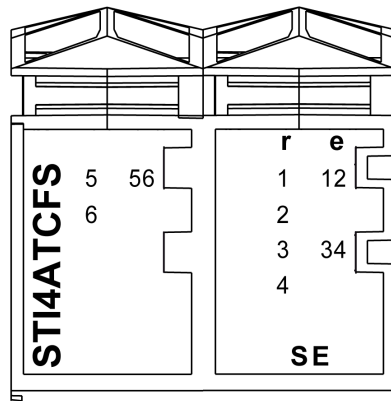



The following tables describe the status LED indicators:

LED indicator	Color	Status	Description
r	off		Module supply not connected.
	green	single flash	reset mode
		double flash	firmware update in progress
		flashing	pre-operational state
	on	RUN state	
e	off		No error detected or module supply not connected.
	red	flashing	boot loader mode
		triple flash	firmware update in progress
		on	error detected
r+e	steady red/single green flash		invalid configuration

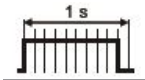
LED indicator	Color	Status	Description
1	off		channel not used
2	red	on	Indicates either an error has been detected for the corresponding input or that the safety-related input is being used as a non-safety-related input.  <b>NOTE:</b> When there is no connection to the Safety Logic Controller, all channels are steady red.
3			
4		flashing	open circuit on corresponding channel
5			
6	green	on	channel being used and signal OK
		flashing	channel outside of the limits configured in EcoStruxure Machine Expert - Safety
12, 34, 56	off		signal on channel pair not OK
	red	on	Indicates a detected error.
	green	on	signal on channel pair OK

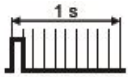
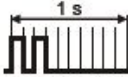
LED indicator	Color	Status	Description
SE	off		RUN state or 24 Vdc supply not present
	red		boot phase or missing TM5 link or non-functioning processor (refer to safety message below)

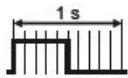
LED indicator	Color	Status	Description
			pre-operational state
			communication channel is not OK
			firmware for this module is a non-certified pilot version <b>NOTE:</b> If you observe this indication, you must immediately replace the module, or update its firmware with a certified version. In all cases, contact your Schneider Electric representative.
			boot phase, inoperable firmware
		on	Safety-related status is active.

Whenever the **S** and **E** LED indicators are illuminated continuously, this indicates that the module is inoperable. There is also a diagnostic available in the Safety Logic Controller to indicate this state. Replacement of the module must be made immediately. It is your responsibility to ensure all necessary repairs are made promptly to enable proper functionality.

## ⚠ WARNING

### LOSS OF SAFETY FUNCTION

- Immediately replace any and all modules that indicate that they are in an inoperable state.
- Ensure that the effect on un-repaired equipment is taken into account in your risk assessment.
- Make all necessary repairs to equipment before re-starting, or continuing service of, your machine.

**Failure to follow these instructions can result in death, serious injury, or equipment damage.**

## TM5STI4ATCFS Characteristics

### Introduction

This section describes the characteristics of the TM5STI4ATCFS module. See also TM5 Environmental Characteristics, page 26.

## ⚠ DANGER

### FIRE HAZARD

Use only the correct wire sizes for the maximum current capacity of the I/O channels and power supplies.

**Failure to follow these instructions will result in death or serious injury.**

<b>⚠ WARNING</b>
<b>UNINTENDED EQUIPMENT OPERATION</b>
Do not exceed any of the rated values specified in the environmental and electrical characteristics tables.
<b>Failure to follow these instructions can result in death, serious injury, or equipment damage.</b>

## General Characteristics

The following table lists the general characteristics of the TM5STI4ATCFS module:

General characteristics		
Rated power supply voltage		24 Vdc
Status indicators		<ul style="list-style-type: none"> <li>I/O functions per channel</li> <li>operating state</li> <li>module status</li> </ul>
Diagnostics	module run and detected error	indicated by status LED indicator and software status
	inputs	indicated by status LED indicator and software status
Electrical isolation <sup>1)</sup>	channel - bus	See note.
	channel - channel	no galvanic isolation
	channel pair - channel pair	See note.
TM5 Bus 5 Vdc current draw		50 mA
24 Vdc I/O segment current draw		50 mA
Certifications and standards		<ul style="list-style-type: none"> <li>CE</li> <li>cULus</li> <li>KC</li> <li>EN IEC 61508:2010</li> <li>EN IEC 62061:2010</li> <li>EN ISO 13849-1:2008</li> <li>EN IEC 61511:2004</li> <li>EN 50156-1:2004</li> </ul>
Maximum internal cycle time		2000 µs
Minimum cycle time		200 µs
Minimum I/O update time		200 µs
Id code for firmware update		46105 dec

**NOTE** <sup>(1)</sup> The isolation of the electronic module is 500 Vac RMS between the electronics power by the TM5 bus and those powered by 24 Vdc I/O power segment connected to the module. In practice, the electronic module is installed in the bus base, and there is a bridge between the TM5 power bus and the 24 Vdc I/O power segment. The two power circuits reference the same functional ground (FE) through specific components designed to reduce effects of electromagnetic interference. These components are rated at 30 Vdc or 60 Vdc. This effectively reduces isolation of the entire system from the 500 Vac RMS.

## Operating Conditions

The following table lists the operating conditions for the TM5STI4ATCFS module:

Operating conditions		
Mounting orientation		horizontal or vertical
Operating temperature	horizontal installation	0...+55 °C (+32...131 °F)
	vertical installation	0...+40 °C (+32...104 °F)
Relative humidity		5...95%, non-condensing
Installation at altitudes above sea level:	0 up to 2000 m (0 up to 6561 ft)	no derating for altitude
	> 2000 m (>6561 ft)	reduction of ambient temperature by 0.5 °C per 100 m (0.9 °F per 328 ft)
EN 60529 Protection type		IP20

## Storage and Transport Conditions

The following table lists the storage and transport conditions for the TM5STI4ATCFS module:

Storage and transport conditions	
Temperature	-25...+70 °C (-13...+158 °F)
Relative humidity	5...95%, non-condensing

## Safety-Related Analog Inputs for Thermocouple Characteristics

The following table lists the analog input characteristics of the TM5STI4ATCFS module:

Analog input		
Number of input channels		2 redundant safety-related analog inputs for thermocouples
Basic accuracy <sup>1)</sup>	type J	0.10%
	type K	0.11%
	type N	0.11%
	type S	0.17%
	type R	0.17%
	type C	0.15%
	type T	0.11%
	voltage	0.06%
Digital converter resolution		24-bit
Input filter		1 first-order low pass / cutoff frequency 500 Hz
Filter time		configurable: 1; 2; 10; 16.7; 20; 33.3; 40; 66.7 ms, refer to following table
Output format		double word integer value
Measurement range	sensor temperature	<ul style="list-style-type: none"> <li>Type J, Fe-CuNi: -210...1200 °C (-346...2192 °F)</li> <li>Type K, NiCr-Ni: -270...1372 °C (-454...2501.6 °F)</li> <li>Type N, NiCrSi-NiSi: -270...1300 °C (-454...2372 °F)</li> <li>Type S, PtRh10-Pt: -50...1768 °C (-58...3214.4 °F)</li> <li>Type R, PtRh13-Pt: -50...1768 °C (-25...3214.4 °F)</li> <li>Type C, WRe5-WRe26: 0...2320 °C (32...4208 °F)</li> </ul>

Analog input		
		<ul style="list-style-type: none"> <li>Type T, Cu-CuNi: -270...400 °C (-454...752 °F)</li> </ul>
	sensor standard	EN IEC 60584-1:2010
	voltage	-65...+65 mV
	maximum internal resistance of the source during voltage measurement	20 Ω
Input signal tolerances		maximum ±1 V
Conversion procedure		sigma delta
Linearization method		internal
Common-mode rejection	DC	70 dB
	50 Hz	70 dB
Common-mode range		<ul style="list-style-type: none"> <li>±4.0 V within channel pair</li> <li>±50 V between 2 channel pairs</li> </ul>
Crosstalk between channels		70 dB
Resolution	sensor temperature	1 LSB = 0.1 °C / 0.18 °F
	voltage	1 LSB = 2 μV
Maximum gain drift <sup>2)</sup>		0.013 % / 1 °C (1.8 °F)
Maximum offset drift <sup>3)</sup>	type J	<0.0021 % / 1 °C (1.8 °F)
	type K	<0.0026 % / 1 °C (1.8 °F)
	type N	<0.0030 % / 1 °C (1.8 °F)
	type S	<0.0090 % / 1 °C (1.8 °F)
	type R	<0.0080 % / 1 °C (1.8 °F)
	type C	<0.0046 % / 1 °C (1.8 °F)
	type T	<0.0050 % / 1 °C (1.8 °F)
	voltage	<0.0013 % / 1 °C (1.8 °F)
Terminal temperature compensation	-	internal / external
	accuracy of the internal terminal temperature	15 °C (27 °F) at static temperatures and during operation
Safety-related accuracy per channel <sup>3)</sup>	type J	2.5 %
	type K	2.9 %
	type N	3.3 %
	type S	8.3 %
	type R	7.4 %
	type C	4.8 %
	type T	4.6 %
	voltage	1.6 %
<sup>1)</sup> = based on the entire measurement range at 25 °C (77 °F) <sup>2)</sup> = based on the measurement value <sup>3)</sup> = based on the entire measurement range		

The following table lists the signal processing time of the module resulting from the set input filter time value (update interval).

**▲ WARNING****UNINTENDED EQUIPMENT OPERATION**

Verify that the signal processing time of the input module is included correctly in the safety response time calculations in EcoStruxure Machine Expert - Safety.

**Failure to follow these instructions can result in death, serious injury, or equipment damage.**

The time needed by the module to generate a sample is specified by the I/O update time.

Configured filter value	Maximum signal processing time of the module
1 ms	32 ms
2 ms	40 ms
10 ms	86 ms
16.7 ms	132 ms
20 ms	152 ms
33.3 ms	240 ms
40 ms	284 ms
66.7 ms	372 ms

**PT100/PT1000 Sensors Characteristics**

The following table lists the PT100/PT1000 sensors characteristics for the TM5STI4ATCFS module

PT100/PT1000 sensors characteristics		
Measurement range	PT100	-40...130 °C (-40...266 °F)
	PT1000	-40...130 °C (-40...266 °F)
Basic accuracy <sup>1)</sup>	PT100	1.1%
	PT1000	0.3%
Measuring current	262 µA ±5%	
Maximum gain drift <sup>2)</sup>	0.004 % / 1 °C (1.8 °F)	
Maximum offset drift	PT100	0.03 % / 1 °C (1.8 °F)
	PT1000	0.003 % / 1 °C (1.8 °F)
Temperature sensor resolution	PT100	1 LSB = 0.1 °C (0.18 °F)
	PT1000	1 LSB = 0.1 °C (0.18 °F)
Input filter	1 first-order low pass / cutoff frequency 500 Hz	
Maximum cable length	50 m (164 ft)	
Maximum line resistance	5 Ω	
Safety-related accuracy per channel <sup>3)</sup>	PT100	4.0 %
	PT1000	2.0 %
<sup>1)</sup> = based on the entire measurement range at 25 °C (77 °F) <sup>2)</sup> = based on the measurement value <sup>3)</sup> = based on the entire measurement range		



## Safety-Related Characteristics

**NOTE:** The following safety-related characteristics only apply when using input channel pairs (for example, TC 1 together with TC 2 or TC 3 with TC 4).

Criteria	Characteristic value for input channel pairs
Maximum performance level according to EN ISO 13849-1:2008	PL e
Category according to EN ISO 13849-1-2008	CAT 4
Maximum safety integrity level according to IEC 62061:2010	SIL 3
Maximum safety integrity level according to IEC 61508:2010	SIL 3
Maximum safety integrity level in accordance with EN IEC 61511:2004	SIL 3
PFH	$<1 \cdot 10^{-9}$
PFD	<ul style="list-style-type: none"> <li>• <math>&lt;5 \cdot 10^{-5}</math> at a proof test interval of 10 years</li> <li>• <math>&lt;1 \cdot 10^{-4}</math> at a proof test interval of 20 years</li> </ul>
PT	maximum 20 years
DC	>94%
SFF	>90%
MTTFd	2200 years
Life time, page 26	20 years

## TM5STI4ATCFS Wiring

### Pin Assignments / Connection Examples

The following channel pair applications are sufficient to achieve maximum PL e (EN ISO 13849-1:2008), maximum SIL 3 (EN IEC 62061:2010), maximum SIL 3 (EN IEC 61508:2010) and maximum SIL 3 (EN IEC 61511:2004).

**TM5STI4ATCFS (with TM5ACTB5FFS, page 194)**

2-wire connection, safety-related PT100/PT1000 input pair:

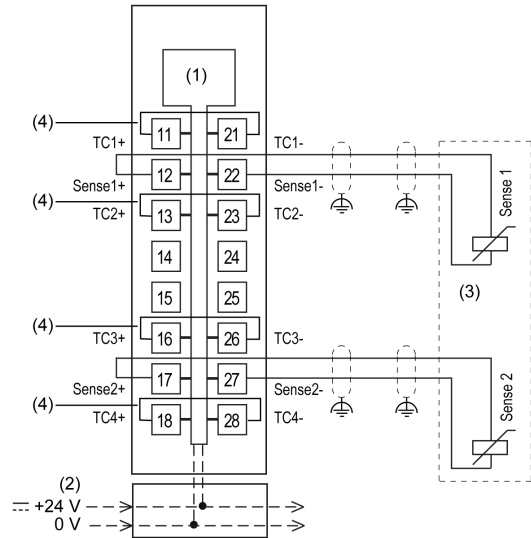

- 1 Internal electronics
- 2 24 Vdc I/O power segment integrated into the bus bases
- 3 2-channel PT100/PT1000 sensor
- 4 Jumper

**TM5STI4ATCFS (with TM5ACTB5EFS, page 194)**

Thermocouple input pair with terminal block for acquiring terminal temperature compensation:

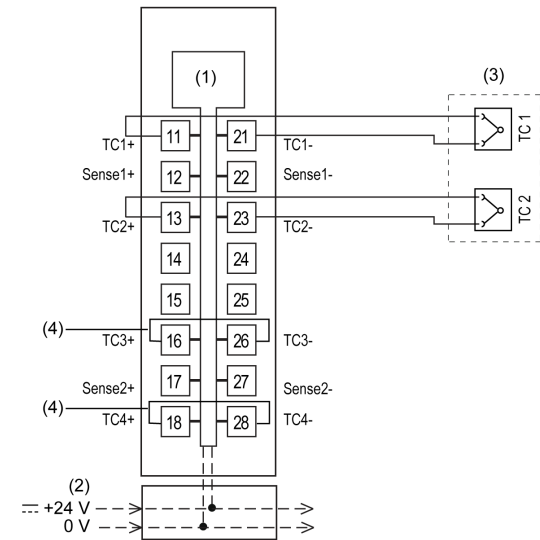

- 1 Internal electronics
- 2 24 Vdc I/O power segment integrated into the bus bases
- 3 2-channel thermocouple sensor
- 4 Jumper

**TM5STI4ATCFS (with TM5ACTB5FFS, page 194)**

Thermocouple input pair, remote terminal temperature compensation, PT100/PT1000 2-wire connection:

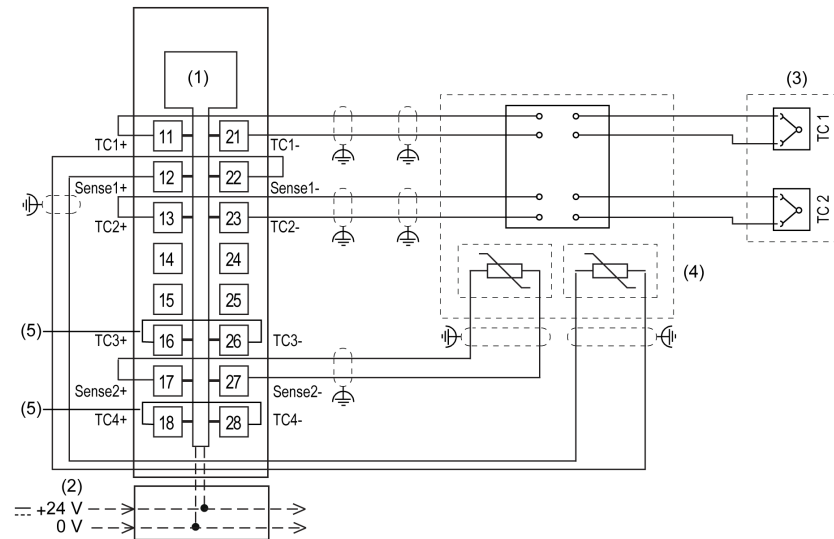

- 1 Internal electronics
- 2 24 Vdc I/O power segment integrated into the bus bases
- 3 2-channel thermocouple sensor
- 4 2-channel PT100/PT1000 sensor
- 5 Jumper

Use shielded, properly grounded cables for all analog and high-speed inputs or outputs and communication connections. If you do not use shielded cable for these connections, electromagnetic interference can cause signal degradation. Degraded signals can cause the controller or attached modules and equipment to perform in an unintended manner.

**▲ WARNING**

**UNINTENDED EQUIPMENT OPERATION**

- Use shielded cables for all fast I/O, analog I/O, and communication signals.
- Ground cable shields for all fast I/O, analog I/O, and communication signals at a single point<sup>1</sup>.
- Route communications and I/O cables separately from power cables.

**Failure to follow these instructions can result in death, serious injury, or equipment damage.**

<sup>1</sup>Multipoint grounding is permissible (and in some cases inevitable) if connections are made to an equipotential ground plane dimensioned to help avoid cable shield damage in the event of power system short-circuit currents.

**▲ WARNING**

**UNINTENDED EQUIPMENT OPERATION**

Do not connect wires to unused terminals and/or terminals indicated as “No Connection (N.C.)”.

**Failure to follow these instructions can result in death, serious injury, or equipment damage.**

# TM5 Safety Counter Module

## What's in This Part

TM5SDC1FS Safety Module DC1 7 kHz 24 Vdc Sink .....	205
---	-----

# TM5SDC1FS Safety Module DC1 7 kHz 24 Vdc Sink

## What's in This Chapter

TM5SDC1FS Presentation..... 205  
 TM5SDC1FS Characteristics ..... 208  
 TM5SDC1FS Wiring ..... 212  
 TM5SDC1FS Function Mode Examples ..... 212

## TM5SDC1FS Presentation

### Main Features

The following table describes the main features of the Safety Counter module TM5SDC1FS:

Main Features	
Number of inputs	1 safety-related input counter channel
Input filter	configurable input filter
Function modes	A-A, A-B, A-A/-B-B/
Signal type	sink
Rated voltage	24 Vdc
Maximum input frequency	7 kHz

This equipment has been designed to operate outside of any hazardous location. Only install this equipment in zones known to be free of a hazardous atmosphere.

 <b>DANGER</b>
<p><b>POTENTIAL FOR EXPLOSION</b></p> <p>Install and use this equipment in non-hazardous locations only.</p> <p><b>Failure to follow these instructions will result in death or serious injury.</b></p>

## Ordering Information

The following figure presents the module in combination with the required components:

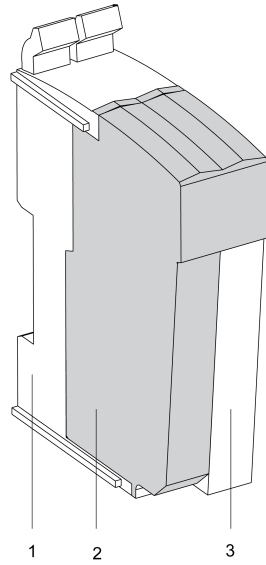

The following table presents the reference of the module:

Number	Reference	Description	Color
2	TM5SDC1FS	TM5 Safety Counter module	red

The following table presents the references for the required components:

Number	Reference	Description	Color
1	TM5ACBM3-FS	TM5 Safety bus base, safety coded, internal I/O supply is interconnected	red
3	TM5ACTB52-FS	TM5 Safety terminal block, 12-pin, safety coded	red

**NOTE:** A TM5 Safety bus base and a TM5 Safety terminal block are required for operation of the module, and are sold separately. For more information, refer to [TM5ACBM3FS Safety bus base, page 232](#) and [TM5ACTB52FS Safety terminal block, page 238](#).

## Status LED Indicators

This figure presents the TM5SDC1FS status LED indicators:

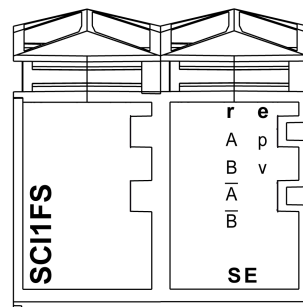



The following tables describe the status LED indicators:

LED indicator	Color	Status	Description
r	off		Module supply not connected.

LED indicator	Color	Status	Description
	green	single flash	reset mode
		double flash	firmware update in progress
		flashing	pre-operational state
		on	RUN state
e	off		No error detected or module supply not connected.
	red	flashing	boot loader mode
		triple flash	firmware update in progress
on	error detected		
r+e	steady red/single green flash		invalid configuration

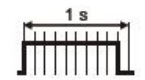
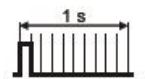
LED indicator	Color	Status	Description
A	off		channel not used
B	red	on	Indicates either an error has been detected for the corresponding input or that the safety-related input is being used as a non-safety-related input.
A/			
B/	green	on	input set
p	-		not used
v	red	on	Indicates a detected error on the evaluation channel.
	green	on	evaluation channel is set

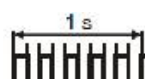
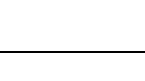
LED indicator	Color	Status	Description
S E	off		RUN state or 24 Vdc supply not present
	red		boot phase or missing TM5 link or non-functioning processor (refer to safety message below)
			pre-operational state
			communication channel is not OK
			firmware for this module is a non-certified pilot version <b>NOTE:</b> If you observe this indication, you must immediately replace the module, or update its firmware with a certified version. In all cases, contact your Schneider Electric representative.
			boot phase, inoperable firmware
	on		Safety-related status is active.

Whenever the **S** and **E** LED indicators are illuminated continuously, this indicates that the module is inoperative. There is also a diagnostic available in the Safety Logic Controller to indicate this state. Replacement of the module must be made immediately. It is your responsibility to ensure all necessary repairs are made promptly to enable proper functionality.

<b>⚠ WARNING</b>
<p><b>LOSS OF SAFETY FUNCTION</b></p> <ul style="list-style-type: none"> <li>• Immediately replace any and all modules that indicate that they are in an inoperable state.</li> <li>• Ensure that the effect on un-repaired equipment is taken into account in your risk assessment.</li> <li>• Make all necessary repairs to equipment before re-starting, or continuing service of, your machine.</li> </ul> <p><b>Failure to follow these instructions can result in death, serious injury, or equipment damage.</b></p>

## TM5SDC1FS Characteristics

### Introduction

This section describes the characteristics of the TM5SDC1FS module. See also TM5 Environmental Characteristics, page 26.

<b>⚠ DANGER</b>
<p><b>FIRE HAZARD</b></p> <p>Use only the correct wire sizes for the maximum current capacity of the I/O channels and power supplies.</p> <p><b>Failure to follow these instructions will result in death or serious injury.</b></p>

<b>⚠ WARNING</b>
<p><b>UNINTENDED EQUIPMENT OPERATION</b></p> <p>Do not exceed any of the rated values specified in the environmental and electrical characteristics tables.</p> <p><b>Failure to follow these instructions can result in death, serious injury, or equipment damage.</b></p>

### General Characteristics

The following table lists the general characteristics of the TM5SDC1FS module:

General characteristics		
Rated power supply voltage		24 Vdc
Status indicators		<ul style="list-style-type: none"> <li>• I/O functions per channel</li> <li>• operating state</li> <li>• module status</li> </ul>
Diagnostics		Module run and detected error conditions indicated by status LED indicator and software status.
Electrical isolation <sup>1)</sup>	channel - bus	See note.
	channel - channel	no galvanic isolation
TM5 Bus 5 Vdc current draw		50 mA
24 Vdc I/O segment current draw		31.3 mA
Certifications and standards		<ul style="list-style-type: none"> <li>• CE</li> <li>• KC</li> <li>• EN IEC 61508:2010</li> </ul>



General characteristics	
	<ul style="list-style-type: none"> <li>• EN IEC 62061:2010</li> <li>• EN ISO 13849-1:2008</li> <li>• EN IEC 61511:2004</li> <li>• EN 50156-1:2004, in preparation</li> </ul>
Maximum internal cycle time	2000 µs
Minimum cycle time	200 µs
Minimum I/O update time	Refer to following table.
Id code for firmware update	51905 dec

**NOTE** <sup>(1)</sup> The isolation of the electronic module is 500 Vac RMS between the electronics power by the TM5 bus and those powered by 24 Vdc I/O power segment connected to the module. In practice, the electronic module is installed in the bus base, and there is a bridge between the TM5 power bus and the 24 Vdc I/O power segment. The two power circuits reference the same functional ground (FE) through specific components designed to reduce effects of electromagnetic interference. These components are rated at 30 Vdc or 60 Vdc. This effectively reduces isolation of the entire system from the 500 Vac RMS.

The time needed by the module to generate a sample is specified by the I/O update time. This depends on the timebase configured in EcoStruxure Machine Expert - Safety.

Timebase	I/O update time
10 ms	2 ms
50 ms	2 ms
100 ms	2 ms
500 ms	5 ms
1 s	10 ms
5 s	50 ms
10 s	100 ms
50 s	500 ms
100 s	1 s

## Operating Conditions

The following table lists the operating conditions for the TM5SDC1FS module:

Operating conditions		
Mounting orientation	horizontal or vertical	
Operating temperature	horizontal installation	0...+55 °C (+32...131 °F), possibility of derating bonus, see note.
	vertical installation	0...+50 °C (+32...122 °F)
Relative humidity	5...95%	
Installation at altitudes above sea level:	0 up to 2000 m (0 up to 6561 ft)	no derating for altitude
	> 2000 m (>6561 ft)	reduction of ambient temperature by 0.5 °C per 100 m (0.9 °F per 328 ft)
EN 60529 protection type	IP20	

**NOTE:** If a TM5SD000 is installed on the side of the module, the horizontal installation derating is shifted to the right by the following derating bonus:

- TM5SD000 to the left: +0 °C (+0 °F)
- TM5SD000 to the right: +2.5 °C (+4.5 °F)
- TM5SD000 to the left and right: +5 °C (+9 °F)

## Storage and Transport Conditions

The following table lists the storage and transport conditions for the TM5SDC1FS module:

Storage and transport conditions	
Temperature	-25...+70 °C (-13...+158 °F)
Relative humidity	5...95%

## Module Supply Characteristics

The following table lists the module supply characteristics for the TM5SDC1FS module

Module supply characteristics	
Integrated protection	reverse polarity protection
Voltage range	20.4...28.8 Vdc

## Safety-Related Input Counter Channel Characteristics

The following table lists the safety-related input counter channel characteristics of the TM5SDC1FS module:

Counter input		
Number of counter channels		1
Rated voltage		24 Vdc
Input filter	hardware	≤10 μs
	software	configurable 0...100 ms
Input frequency		maximum 7 kHz
Input circuit		sink
Input voltage range		20.4...28.8 Vdc
Input current at 24 Vdc		typical: 2.48 mA
Input resistance		typical: 9.68 kΩ
OFF state (switching threshold low)		<5 Vdc
ON state (switching threshold high)		>15 Vdc
Isolation voltage between channel and bus <sup>1)</sup>		See note.
Maximum cable length		30 m / 98 ft (shielded)

**NOTE** <sup>(1)</sup> The isolation of the electronic module is 500 Vac RMS between the electronics power by the TM5 bus and those powered by 24 Vdc I/O power segment connected to the module. In practice, the electronic module is installed in the bus base, and there is a bridge between the TM5 power bus and the 24 Vdc I/O power segment. The two power circuits reference the same functional ground (FE) through specific components designed to reduce effects of electromagnetic interference. These components are rated at 30 Vdc or 60 Vdc. This effectively reduces isolation of the entire system from the 500 Vac RMS.

## Encoder Supply Characteristics

The following table lists the encoder supply characteristics of the TM5SDC1FS module:

Encoder supply characteristics	
Output voltage	module supply minus residual voltage
Rated output current	80 mA
Residual voltage	< 0.4 Vdc
Short circuit protection	thermal limit determined by PTC

## Safety-Related Characteristics

The following table lists the safety-related characteristics of the TM5SDC1FS module:

Criteria	Characteristic value
Maximum performance level according to EN ISO 13849-1:2008	PL e
Category according to EN ISO 13849-1:2008	CAT 4  The special instructions in the section TM5SC11FS Function Mode Examples, page 212 must be followed.
Maximum safety integrity level according to EN IEC 62061:2010	SIL 3
Maximum safety integrity level according to EN IEC 61508:2010	SIL 3
Maximum safety integrity level according to EN IEC 61511:2004	SIL 3
PFH	$<1 \cdot 10^{-10}$
PFD	<ul style="list-style-type: none"> <li>• <math>&lt;1 \cdot 10^{-5}</math> at a proof test interval of 10 years</li> <li>• <math>&lt;2 \cdot 10^{-5}</math> at a proof test interval of 20 years</li> </ul>
PT	maximum 20 years
DC	>94%
SFF	>90%
MTTFd	2500 years
Life time, page 26	20 years

# TM5SDC1FS Wiring

## Pin Assignments / Connection Example

The following figure presents a connection example for the TM5SDC1FS:

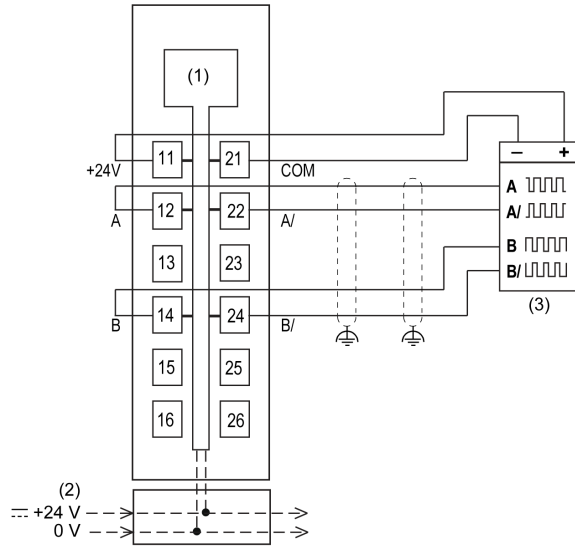

- 1 Internal electronics
- 2 24 Vdc I/O power segment integrated into the bus bases
- 3 4-channel sensor with internal power supply

<b>⚠ WARNING</b>
<p><b>UNINTENDED EQUIPMENT OPERATION</b></p> <p>Do not connect wires to unused terminals and/or terminals indicated as “No Connection (N.C.)”.</p> <p><b>Failure to follow these instructions can result in death, serious injury, or equipment damage.</b></p>

<b>⚠ WARNING</b>
<p><b>UNINTENDED EQUIPMENT OPERATION</b></p> <p>Use the sensor and actuator power supply only for supplying power to sensors or actuators connected to the module.</p> <p><b>Failure to follow these instructions can result in death, serious injury, or equipment damage.</b></p>

# TM5SDC1FS Function Mode Examples

## Overview

The connection examples in this section only represent a selection of the different wiring methods. You must take error detection into consideration in each case.

## Function Mode A-A: Single-Channel Encoder

Function mode A-A: Single-channel encoder

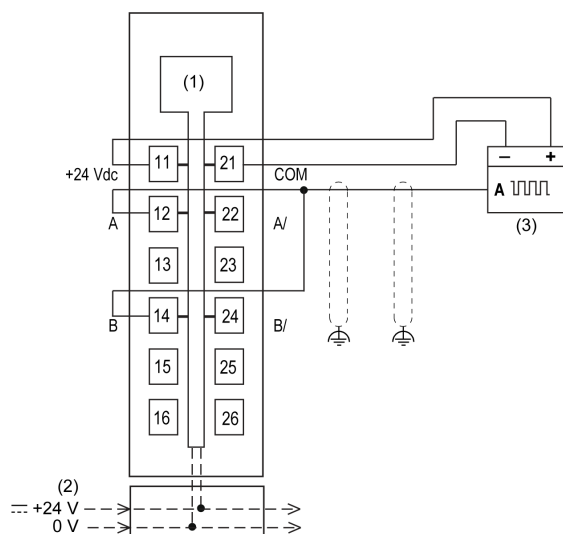

1 Internal electronics

2 24 Vdc I/O power segment integrated into the bus bases

3 1-channel sensor with internal power supply

Signal form A-A

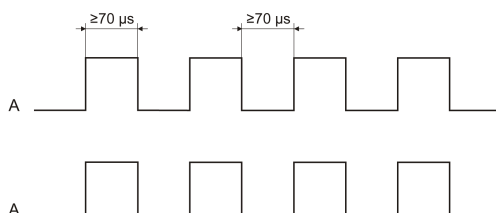

Safety-related characteristics criteria	Characteristic value
Category in accordance with EN ISO 13849-1:2008 (module and encoder)	CAT 2
Safety-related recording of the rotary speed	yes if rotary speed >0
Safety-related comparison of the rotary speed	no
Safety-related recording of the direction of rotation	no
Safety-related stall detection	no
<b>Encoder wiring instructions</b>	
<ul style="list-style-type: none"> <li>Use shielded cables for encoder wiring.</li> <li>Cable length: maximum 30 m (98 ft)</li> </ul>	
<b>Information regarding the encoder</b>	
<ul style="list-style-type: none"> <li>The encoder must be taken into consideration when assessing and validating the safety-related chain.</li> <li>Encoders with output signal test pulses (OSSD) are not permitted to be used because the test pulses would result in incorrect measurements on the counter channel.</li> <li>The encoder signal levels must be compatible with the input channels. Here, the characteristic values listed in the technical data must be taken into account.</li> </ul>	
<b>Information regarding the encoder supply</b>	
<ul style="list-style-type: none"> <li>The design of the encoder supply must ensure proper operation and the correct signal level (&lt;5 Vdc low, &gt;15 Vdc high).</li> </ul>	

## Function Mode A-A: Two-Channel Encoder

Function mode A-A: Two-channel encoder

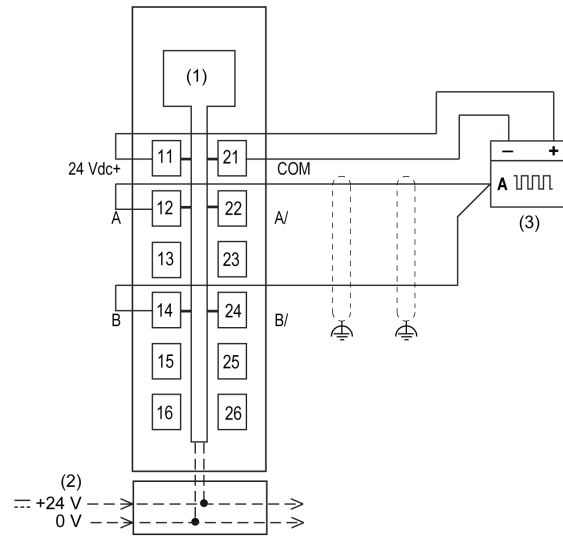

1 Internal electronics

2 24 Vdc I/O power segment integrated into the bus bases

3 2-channel sensor with internal power supply

Signal form A-A

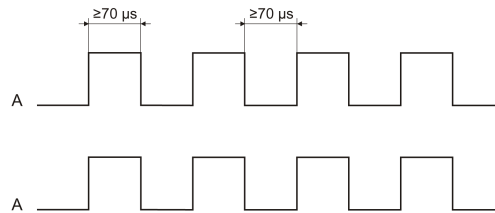

Safety-related characteristics criteria	Characteristic value
Category in accordance with EN ISO 13849-1:2008 (module and encoder)	CAT 4
Safety-related recording of the rotary speed	yes if rotary speed >0
Safety-related comparison of the rotary speed	yes; permissible tolerance is 5 counter pulses per "Timebase"; evaluation using the "SafeFrequencyOK" signal is possible
Safety-related recording of the direction of rotation	no
Safety-related stall detection	no
<b>Encoder wiring instructions</b>	
<ul style="list-style-type: none"> <li>Two separate and shielded lines must be used to wire both encoders.</li> </ul>	
<b>Information regarding the encoder</b>	
<ul style="list-style-type: none"> <li>The encoder must be taken into consideration when assessing and validating the safety-related chain.</li> <li>Encoders with output signal test pulses (OSSD) are not permitted to be used because the test pulses would result in incorrect measurements on the counter channel.</li> <li>The encoder signal levels must be compatible with the input channels. Here, the characteristic values listed in the technical data must be taken into account.</li> <li>The two "A" signals must be generated by independent encoders.</li> </ul>	
<b>Information regarding the encoder supply</b>	
<ul style="list-style-type: none"> <li>The design of the encoder supply must ensure proper operation and the correct signal level (&lt;5 Vdc low, &gt;15 Vdc high).</li> </ul>	

## Function Mode A-B

### Function mode A-B

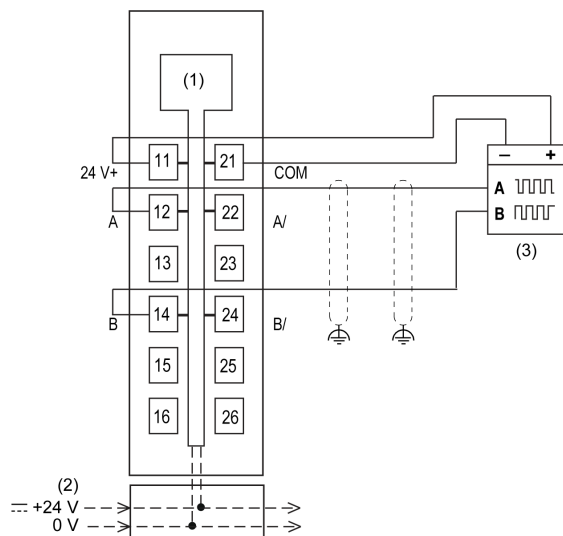

#### 1 Internal electronics

#### 2 24 Vdc I/O power segment integrated into the bus bases

#### 3 2-channel sensor with internal power supply

#### Signal form A-B

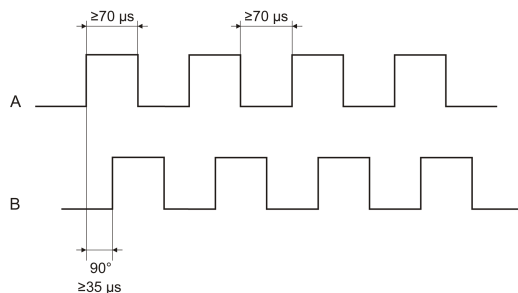

Safety-related characteristics criteria	Characteristic value
Category in accordance with EN ISO 13849-1:2008 (module and encoder)	CAT 4
Safety-related recording of the rotary speed	yes if rotary speed >0
Safety-related comparison of the rotary speed	yes; permissible tolerance is 5 counter pulses per "Timebase"; evaluation using the "SafeFrequencyOK" signal is possible
Safety-related recording of the direction of rotation	no
Safety-related stall detection	no
<b>Encoder wiring instructions</b>	
<ul style="list-style-type: none"> <li>Use shielded cables for encoder wiring.</li> <li>Cable length: maximum 30 m (98 ft)</li> </ul>	
<b>Information regarding the encoder</b>	
<ul style="list-style-type: none"> <li>The encoder must be taken into consideration when assessing and validating the safety-related chain.</li> <li>Encoders with output signal test pulses (OSSD) are not permitted to be used because the test pulses would result in incorrect measurements on the counter channel.</li> <li>The encoder signal levels must be compatible with the input channels. Here, the characteristic values listed in the technical data must be taken into account.</li> <li>The "A" and "B" signals must be generated by independent encoders. If "AB" encoders are used, it is necessary to ensure that the "A" signal is generated in the encoder independent of the "B" signal.</li> </ul>	

<b>Information regarding the encoder supply</b>
<ul style="list-style-type: none"> <li>The design of the encoder supply must ensure proper operation and the correct signal level (&lt;5 Vdc low, &gt;15 Vdc high).</li> </ul>

### Function Mode A-A/-B-B/

Function mode A-A/-B-B/

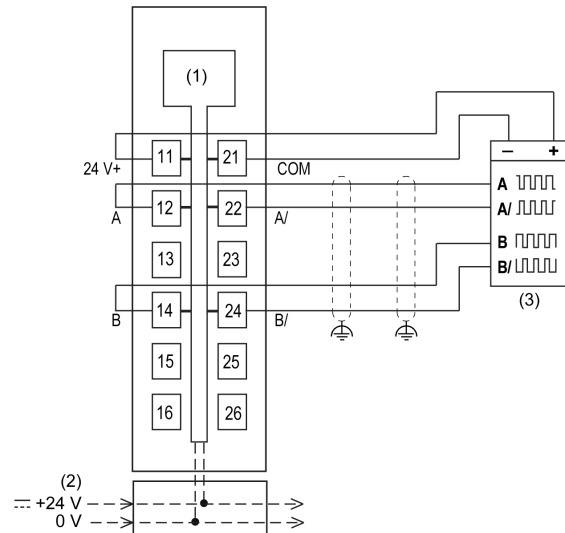

1 Internal electronics

2 24 Vdc I/O power segment integrated into the bus bases

3 4-channel sensor with internal power supply

Signal form A-A/-B-B/

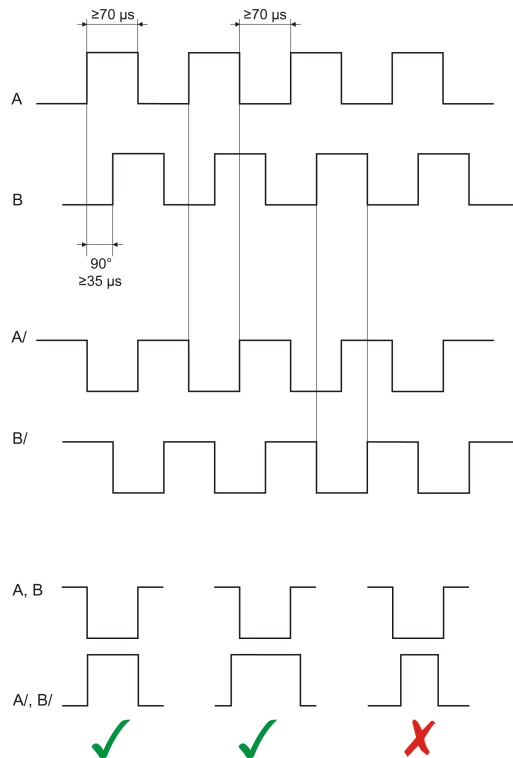

Safety-related characteristics criteria	Characteristic value
Category in accordance with EN ISO 13849-1:2008 (module and encoder)	CAT 4
Safety-related recording of the rotary speed	yes if rotary speed >0



Safety-related characteristics criteria	Characteristic value
Safety-related comparison of the rotary speed	no
Safety-related recording of the direction of rotation	yes
Safety-related stall detection	yes
<b>Encoder wiring instructions</b>	
<ul style="list-style-type: none"> <li>• Use shielded cables for encoder wiring.</li> <li>• Cable length: maximum 30 m (98 ft)</li> </ul>	
<b>Information regarding the encoder</b>	
<ul style="list-style-type: none"> <li>• The encoder must be taken into consideration when assessing and validating the safety-related chain.</li> <li>• Encoders with output signal test pulses (OSSD) are not permitted to be used because the test pulses would result in incorrect measurements on the counter channel.</li> <li>• The encoder signal levels must be compatible with the input channels. Here, the characteristic values listed in the technical data must be taken into account.</li> <li>• The "A", "A/", "B" and "B/" signals must be generated by independent encoders. If "AA/BB/" encoders are used, it is necessary to ensure that all signals are generated in the encoder independent of the others.</li> </ul>	
<b>Information regarding the encoder supply</b>	
<ul style="list-style-type: none"> <li>• The design of the encoder supply must ensure proper operation and the correct signal level (&lt;5 Vdc low, &gt;15 Vdc high).</li> </ul>	

# TM5 Safety Power Distribution Module

## What's in This Part

TM5SPS10FS Safety Module PS 1DO 24 Vdc.....	219
---	-----

# TM5SPS10FS Safety Module PS 1DO 24 Vdc

## What's in This Chapter

TM5SPS10FS Presentation ..... 219  
 TM5SPS10FS Characteristics ..... 225  
 TM5SPS10FS Wiring ..... 230

## TM5SPS10FS Presentation

### Introduction

The TM5SPS10FS Safety Power Distribution module (SPDM), in association with its dedicated, left-isolating TM5ACBM4FS Safety bus base, is a power source for specified non-safety-related I/O modules. The Safety Power Distribution module supports the pre-defined safe state of power-off (de-energized) to the I/O modules connected. As illustrated below, the TM5SPS10FS Safety Power Distribution module is used to create an isolated group of non-safety related I/O modules.

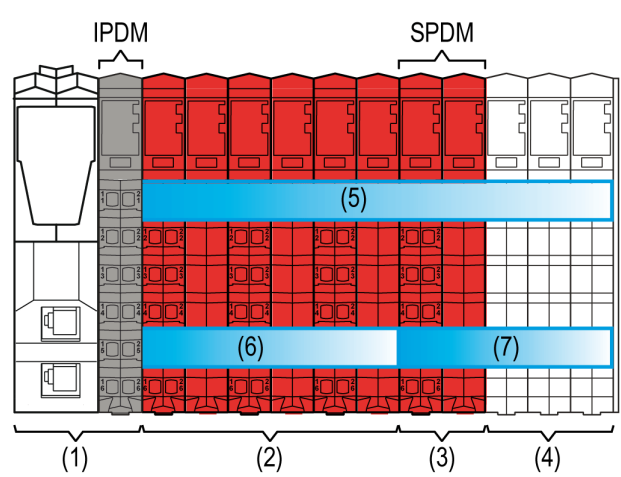

- (1) Sercos III Bus Interface
- (2) Safety I/O modules
- (3) TM5SPS10FS Safety Power Distribution module
- (4) Non-safety-related I/O modules
- (5) TM5 bus and electronic module power supply
- (6) 24 Vdc I/O power segment of safety-related I/O modules
- (7) 24 Vdc I/O power segment of non-safety-related I/O modules

**IDPM** Interface power distribution module

**SDPM** Safety Power Distribution module: TM5SPS10FS

In the case of a safety-related request by the Safety Logic Controller, the Safety Power Distribution module disables the 24 Vdc I/O power segment bus. Consequently, power to the connected sensors and actuators of those I/O modules using the bus within the segment is removed. Likewise, the 24 Vdc safety-related output of the Safety Power Distribution module is disabled.

In an appropriate hardware configuration, the 24 Vdc safety-related output of the Safety Power Distribution module can be used to remove power from an external power supply directly, removing residual connection to power. For example, output voltage and current may need to be removed from, in addition to those connected to the internal 24 Vdc I/O power segment bus, external relays, contactors, drive inputs or other forms of actuators.

Principally, however, the 24 Vdc safety-related output of the Safety Power Distribution module (SPDM) is used to supply a non-safety-related Power Distribution Module (PDM), as illustrated in the following graphic:

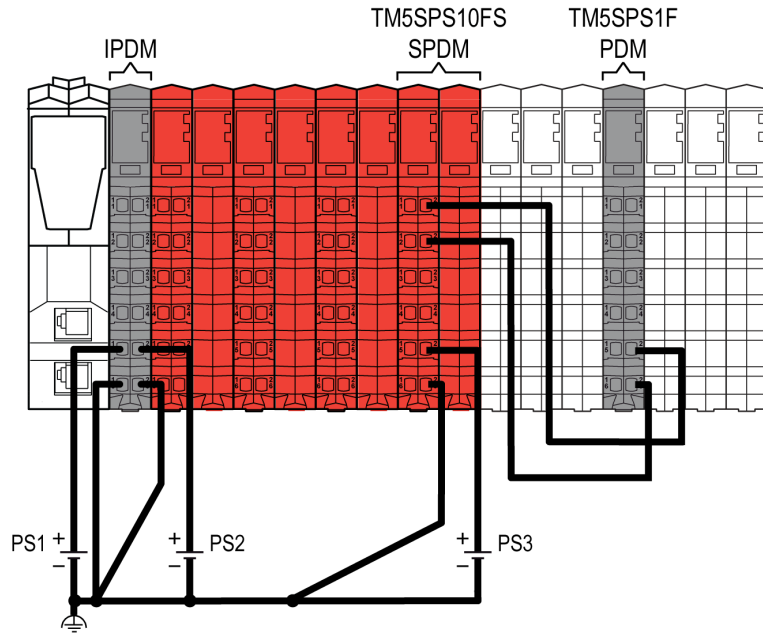

**(PS1)** External isolated power supply 24 Vdc

**(PS2)** External isolated power supply 24 Vdc

**(PS3)** External isolated power supply 24 Vdc

An SPDM can only de-energize a maximum of 10 A output current of connected non-safety-related I/O modules.

**⚠ WARNING**

**UNINTENDED EQUIPMENT OPERATION**

- If you need to de-energize more than 10 A, add more SPDM modules.
- Make sure that direct voltage is only and exclusively supplied by the SPDM to any non-safety-related I/O module that is to be de-energized.
- Make sure that the segment on the right side of the SPDM does not contain any bus base and module combination that can provide external power to the 24 Vdc I/O power segment bus to the left (to the SPDM).

**Failure to follow these instructions can result in death, serious injury, or equipment damage.**

**⚠ WARNING**

**UNINTENDED EQUIPMENT OPERATION**

- Only connect the non-safety-related I/O modules specified as compatible by the present documentation to the Safety Power Distribution module.
- If using an external source of power to supply sensors and/or actuators of the connected I/O modules, use the 24 Vdc output of the Safety Power Distribution module to control the removal of power provided by the external source.
- Only use one Safety Power Distribution module for the potential group of non-safety-related I/O modules.

**Failure to follow these instructions can result in death, serious injury, or equipment damage.**

The following table indicates the compatible non-safety-related I/O modules that you can connect to the TM5SPS10FS Safety Power Distribution module slice:

(Non-safety-related) reference	Description
TM5SAO2H <sup>(1)</sup>	Electronic Module 2AO ±0V/0-20mA 16 Bits
TM5SAO2L <sup>(1)</sup>	Electronic Module 2AO ±0V/0-20mA 12 Bits
TM5SAO4H <sup>(1)</sup>	Electronic Module 4AO ±0V/0-20mA 16 Bits
TM5SAO4L <sup>(1)</sup>	Electronic Module 4AO ±0V/0-20mA 12 Bits
TM5SDO12T	Electronic Module 12DO 24 Vdc Tr 0.5 A 1 Wire
TM5SDO2T	Electronic Module 2DO 24 Vdc Tr 0.5 A 3 Wires
TM5SDO4T	Electronic Module 4DO 24 Vdc Tr 0.5 A 3 Wires
TM5SDO4TA	Electronic Module 4DO 24 Vdc Tr 2 A 3 Wires
TM5SDO8TA	Electronic Module 8DO 24 Vdc Tr 2 A 1 Wire
TM5SDO6T	Electronic Module 6DO 24 Vdc Tr 0.5 A 2 Wires
TM5SDO16T	Electronic Module 16DO 24 Vdc Tr 0.5 A 1 Wire
TM5SPS1	PDM Electronic Module 24 Vdc I/O
TM5SPS1F	PDM Electronic Module 24 Vdc I/O Fuse 6.3 A
TM5ACBM11	Bus base 24 Vdc
TM5ACBM01R	Bus base 24 Vdc for PDM and Receiver modules
TM7BAM4CLA <sup>(1)</sup>	Block 2AI/2AO 0-20 mA
TM7BAM4VLA <sup>(1)</sup>	Block 2AI/2AO ±0 Vdc
TM7BAO4CLA <sup>(1)</sup>	Block 4AO 0-20 mA
TM7BAO4VLA <sup>(1)</sup>	Block 4AO ±0 Vdc
TM7BDM16A <sup>(1)</sup>	Block 16 Configurable DI/DO 24 Vdc
TM7BDM16B <sup>(1)</sup>	Block 16 Configurable DI/DO 24 Vdc
TM7BDM8B <sup>(1)</sup>	Block 8 Configurable DI/DO 24 Vdc
TM7BDO8TAB <sup>(1)</sup>	Block 8DO 24 Vdc Source

<sup>(1)</sup> Some modules use the 24 V I/O Power Segment as a source of power for communications on the TM5 bus. When the Safety Power Distribution module removes power from the 24 V I/O Power Segment, these modules cease communication with the Sercos III Bus Interface, which then will produce configuration exceptions. For example, when the Safety Power Distribution module removes power, these modules cannot be found during a Sercos SCAN procedure.

**NOTE:** All compatible TM5 Electronic Modules must be of a revision PV: 01 / RL: 02 or greater.

 **⚠ DANGER**

**INCOMPATIBLE COMPONENTS CAUSE ELECTRIC SHOCK OR ARC FLASH**

- Do not associate components of a slice that have different colors.
- Verify that correct terminal blocks (minimally, matching colors and correct number of terminals) are installed on the appropriate electronic modules.

**Failure to follow these instructions will result in death or serious injury.**

Part of the defined safe state is to achieve the operational definition of the removal of power. After the removal of power to an external power supply, power must remain removed for a period of at least 250 ms, and up to 1 s to prevent the restart of an actuator. This time is required to discharge any internal energy storage to affect the shut-down of the actuators.

The safety-related function initiating the removal of power must fulfill the requirements of the intended overall safety level (Category, PL, etc.) as determined by your risk assessment. The concept of the TM5SPS10FS Safety

Power Distribution module can, with an appropriate architecture, achieve a safety objective up to Category 4 / PL e according to EN ISO 13849-1.

### Main Features

The following table describes the main features of the Safety Power Distribution module TM5SPS10FS:

Main Features	
Number of outputs	1 safety-related digital FET output with current monitoring
Rated voltage	24 Vdc
Rated output current	10 A
Output protection	Integrated over-current protection and inductive load resistance
Module supply	1 module supply

This equipment has been designed to operate outside of any hazardous location. Only install this equipment in zones known to be free of a hazardous atmosphere.

**⚠ DANGER**

**POTENTIAL FOR EXPLOSION**

Install and use this equipment in non-hazardous locations only.

**Failure to follow these instructions will result in death or serious injury.**

### Ordering Information

The following figure presents the module in combination with the required components:

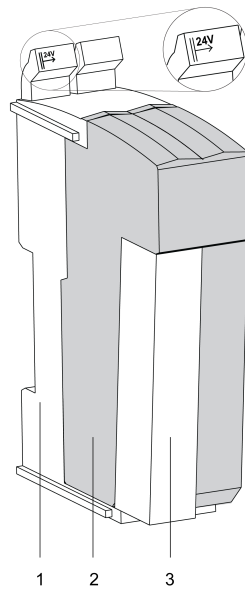

The following table presents the reference of the module:

Num-ber	Reference	Description	Color
2	TM5SPS10FS	TM5 Safety Power Distribution module	red

The following table presents the references for the required components:

Number	Reference	Description	Color
1	TM5ACBM4-FS	TM5 Safety bus base, safety coded, internal I/O supply is interrupted to the left	red
3	TM5ACTB52-FS	TM5 Safety terminal block, 12-pin, safety coded	red

**NOTE:** A TM5 Safety bus base and a TM5 Safety terminal block are required for operation of the module, and are sold separately. For more information, refer to TM5ACBM4FS Safety bus base, page 235 and TM5ACTB52FS Safety terminal block, page 238.

**NOTE:** To identify the bus base type (voltage routing) being used even when an electronic module is inserted, the bus bases with I/O supply left isolated are identified by a marking on the upper locking lever (||-> 24V).

**⚠ WARNING**

**IMPROPER ASSOCIATION OF COMPONENT**

Use only the left isolated Safety bus base TM5ACBM4FS in association with the TM5SPS10FS Safety Power Distribution module.

**Failure to follow these instructions can result in death, serious injury, or equipment damage.**

### Status LED Indicators

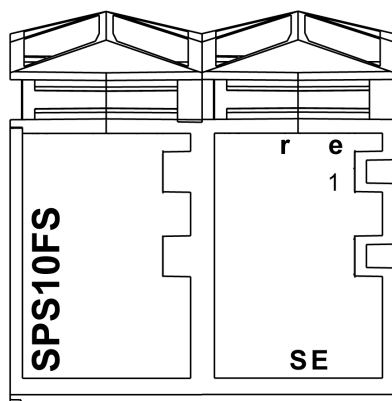

This figure presents the TM5SPS10FS status LED indicators:



The following tables describe the status LED indicators:

LED indicator	Color	Status	Description
r	off		Module supply not connected.
	green	single flash	reset mode
		double flash	firmware update in progress
		flashing	pre-operational state
		on	RUN state
e	off		No error detected or module supply not connected.
	red	flashing	boot loader mode
		triple flash	firmware update in progress
		on	error detected
r+e	steady red/single green flash		invalid configuration

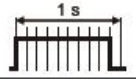
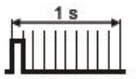
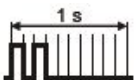
LED indicator	Color	Status	Description
1	-		Power status
	red	on	An error has been detected on the output channel. The connection to the Safety Logic Controller is not operational or the start-up phase has not yet been completed.
	orange	on	nominal 24 Vdc power output

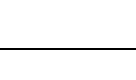
LED indicator	Color	Status	Description
S E	off		RUN state or 24 Vdc supply not present
	red		boot phase or missing TM5 link or non-functioning processor (refer to safety message below)
			pre-operational state
			communication channel is not OK
			firmware for this module is a non-certified pilot version <b>NOTE:</b> If you observe this indication, you must immediately replace the module, or update its firmware with a certified version. In all cases, contact your Schneider Electric representative.
			boot phase, inoperable firmware
	on		Safety-related status is active.

Whenever the **S** and **E** LED indicators are illuminated continuously, this indicates that the module is inoperative. There is also a diagnostic available in the Safety Logic Controller to indicate this state. Replacement of the module must be made immediately. It is your responsibility to ensure all necessary repairs are made promptly to enable proper functionality.

⚠ WARNING
<p><b>LOSS OF SAFETY FUNCTION</b></p> <ul style="list-style-type: none"> <li>• Immediately replace any and all modules that indicate that they are in an inoperable state.</li> <li>• Ensure that the effect on un-repaired equipment is taken into account in your risk assessment.</li> <li>• Make all necessary repairs to equipment before re-starting, or continuing service of, your machine.</li> </ul> <p><b>Failure to follow these instructions can result in death, serious injury, or equipment damage.</b></p>



# TM5SPS10FS Characteristics

## Introduction

This section describes the characteristics of the TM5SPS10FS module. See also TM5 Environmental Characteristics, page 26.

<b>⚠ DANGER</b>
<p><b>FIRE HAZARD</b></p> <p>Use only the correct wire sizes for the maximum current capacity of the I/O channels and power supplies.</p> <p><b>Failure to follow these instructions will result in death or serious injury.</b></p>

<b>⚠ WARNING</b>
<p><b>UNINTENDED EQUIPMENT OPERATION</b></p> <p>Do not exceed any of the rated values specified in the environmental and electrical characteristics tables.</p> <p><b>Failure to follow these instructions can result in death, serious injury, or equipment damage.</b></p>

## General Characteristics

The following table lists the general characteristics of the TM5SPS10FS module:

General characteristics		
Rated power supply voltage		24 Vdc
Status indicators		<ul style="list-style-type: none"> <li>• Output status</li> <li>• Operating state</li> <li>• Module status</li> </ul>
Diagnostics	Module run and detected error	Indicated by status LED indicator and software status.
	Outputs	Indicated by status LED indicator and software status (output status, current measurement).
Electrical isolation <sup>(1)</sup>	Channel - bus	See note.
TM5 Bus 5 Vdc current draw		40 mA
24 Vdc I/O segment current draw		62.5 mA
Maximum switching frequency		<ul style="list-style-type: none"> <li>• 2 commutations per 48 s (for EcoStruxure Machine Expert V1.2.x and earlier versions / module FW version ≤ 320)</li> <li>• &lt; 2 Hz (for EcoStruxure Machine Expert V2.0 and later versions / module FW version &gt; 320)</li> </ul> <p>Also refer to section “Switching inductive loads” below.</p>
Certifications and standards		<ul style="list-style-type: none"> <li>• CE</li> <li>• cULus</li> <li>• KC</li> <li>• EN IEC 61508:2010</li> <li>• EN IEC 62061:2013</li> <li>• EN ISO 13849-1:2015</li> <li>• EN IEC 61511:2004</li> <li>• EN 50156-1:2004</li> </ul>
Maximum internal cycle time		800 μs
Minimum cycle time		200 μs

General characteristics	
Minimum I/O update time	400 µs
Maximum I/O update time	1600 µs
Id code for firmware update	7615 dec

**NOTE** <sup>(1)</sup> The isolation of the electronic module is 500 Vac RMS between the electronics power by the TM5 bus and those powered by 24 Vdc I/O power segment connected to the module. In practice, the electronic module is installed in the bus base, and there is a bridge between the TM5 power bus and the 24 Vdc I/O power segment. The two power circuits reference the same functional ground (FE) through specific components designed to reduce effects of electromagnetic interference. These components are rated at 30 Vdc or 60 Vdc. This effectively reduces isolation of the entire system from the 500 Vac RMS.

Switching inductive loads:

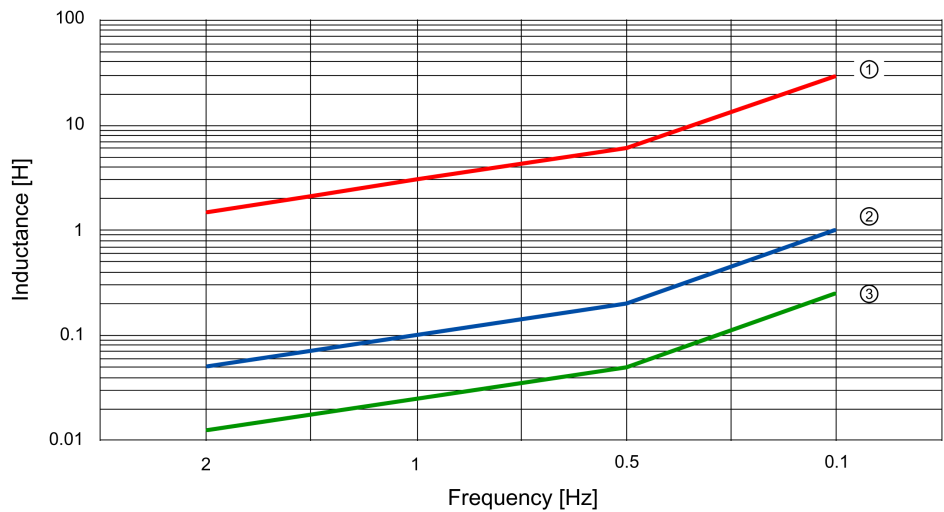

- 1 Maximum permissible output current 1 A
- 2 Maximum permissible output current 5 A
- 3 Maximum permissible output current 10 A

## Operating Conditions

The following table lists the operating conditions for the TM5SPS10FS module:

Operating conditions		
Mounting orientation		Horizontal or vertical
Operating temperature	Horizontal installation	0...+55 °C (+32...131 °F), for derating refer to following table <sup>1</sup>
	Vertical installation	0...+35 °C (+32...95 °F), for derating refer to following table <sup>1</sup>
Relative humidity		5...95%, non-condensing
Installation at altitudes above sea level:	0 up to 2000 m (0 up to 6561 ft)	No derating for altitude
	> 2000 m (>6561 ft)	Reduction of ambient temperature by 0.5 °C per 100 m (0.9 °F per 328 ft)
EN 60529 Protection type		IP20

<sup>1</sup> Derating in relation to operating temperature and mounting orientation

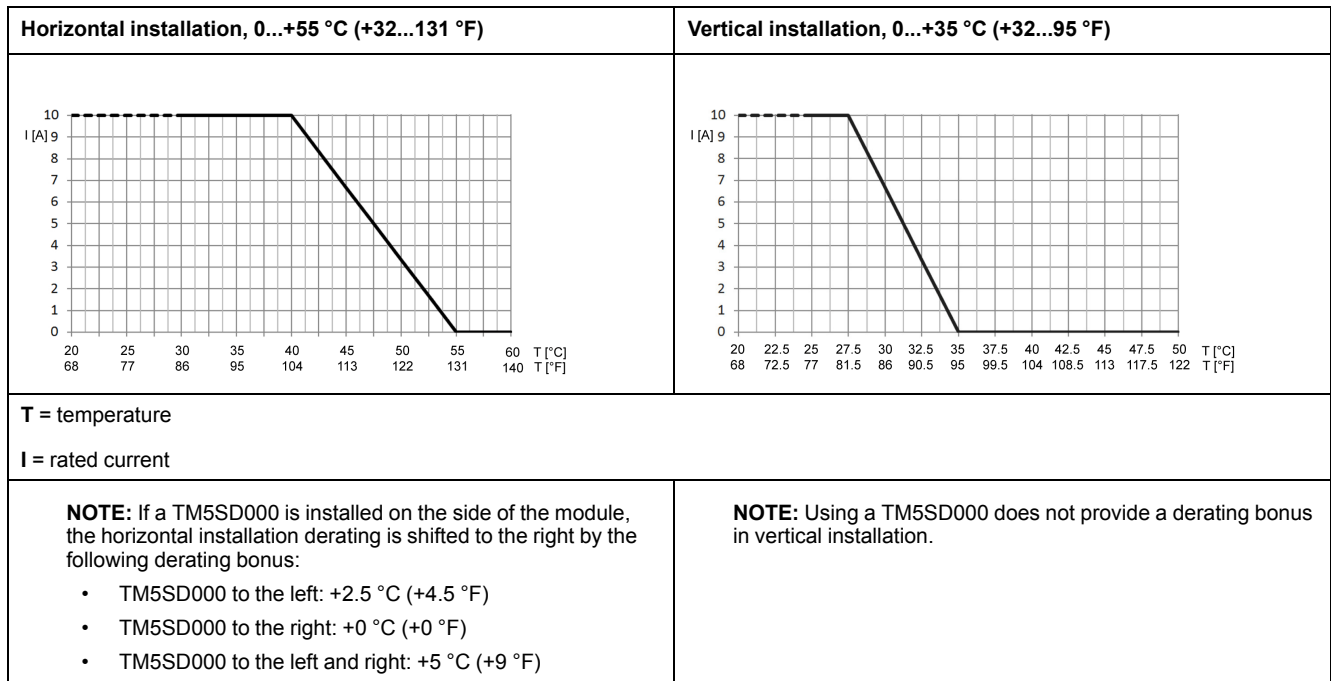

### Storage and Transport Conditions

The following table lists the storage and transport conditions for the TM5SPS10FS module:

Storage and transport conditions	
Temperature	-40...+85 °C (-40...+185 °F)
Relative humidity	5...95%, non-condensing

### Module Supply Characteristics

The following table lists the module supply characteristics for the TM5SPS10FS module

Module supply characteristics	
Integrated protection	Overcurrent cutoff, protection for inductive switching
Rated voltage	24 Vdc
Voltage range	20.4...28.8 Vdc

### Power Output Characteristics

The following table lists the power output characteristics of the TM5SPS10FS module:

Power output	
Number of output channels	1
Design	2 FETs in series, output level can be read
Rated voltage	24 Vdc
Rated output current	10 A
Output protection	Refer to section “Inrush current behavior for output channels” below.
Braking voltage when switching off inductive loads	1 Vdc

Power output	
Diagnostics status	Output monitoring, current measurement (shutdown in the event of overcurrent).
Re-arming after overload or short circuit detection	Power up
Peak output current	11 A
Leakage current when switched off	1 mA
Residual voltage	≤200 mVdc at rated output current
Switching voltage	Module supply minus residual voltage
Maximum capacitive load	1 mF
Minimum load	15 mA
Isolation voltage between channel and bus <sup>1)</sup>	See note.
Error detection time	2 s

**NOTE** <sup>(1)</sup> The isolation of the electronic module is 500 Vac RMS between the electronics power by the TM5 bus and those powered by 24 Vdc I/O power segment connected to the module. In practice, the electronic module is installed in the bus base, and there is a bridge between the TM5 power bus and the 24 Vdc I/O power segment. The two power circuits reference the same functional ground (FE) through specific components designed to reduce effects of electromagnetic interference. These components are rated at 30 Vdc or 60 Vdc. This effectively reduces isolation of the entire system from the 500 Vac RMS.

In addition to the rated output current specified, the output channels indicate the following for increased inrush current.

Inrush current behavior for output channels:

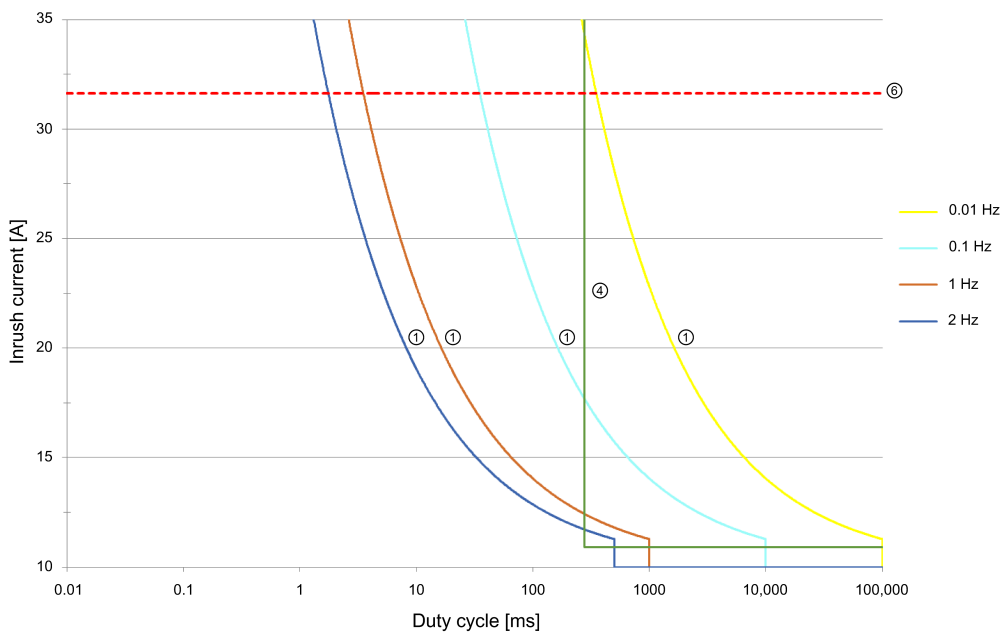

**1** Limits during cyclic switching operations. These curves show the maximum possible total inrush currents of all channels of the module during cyclic switching operations depending on the switching frequency. Overshooting these values results in overheating of the module.

**4** Current monitoring of the firmware - maximum inrush current per channel. These output channels are equipped with overcurrent detection in the firmware of the module. The curve shows the maximum inrush current per channel. Overshooting results in the shutdown of the output channel.

**6** Component load capacity of the module. This limit shows the total inrush current from which individual components of the module are overloaded. Overshooting can result in irreparable damage to the module.

**NOTE:** The protective function is provided for maximum 30 minutes for a continuous short circuit.

<b>▲ WARNING</b>
<p><b>UNINTENDED EQUIPMENT OPERATION</b></p> <p>Install and operate this equipment according to the conditions described in the Environmental Characteristics.</p> <p><b>Failure to follow these instructions can result in death, serious injury, or equipment damage.</b></p>

### Safety-Related Characteristics

The following table lists the safety-related characteristics of the TM5SPS10FS module:

Criteria	Characteristic value for output channels
EN ISO 13849-1-2015	Category:CAT 4 PL (maximum performance level): PL e DC: >94% MTTFd: 2500 years Life time, page 26: 20 years
IEC 61508:2010, IEC 61511:2004, EN 62061:2013	SIL CL (maximum safety integrity level): SIL 3 SFF: >90% PFH: <1*10 <sup>-10</sup> PFD: <2*10 <sup>-5</sup> at a proof test interval of 20 years PT: Maximum 20 years

# TM5SPS10FS Wiring

## Pin Assignments / Connection Example

The following figure presents a connection example for the TM5SPS10FS:

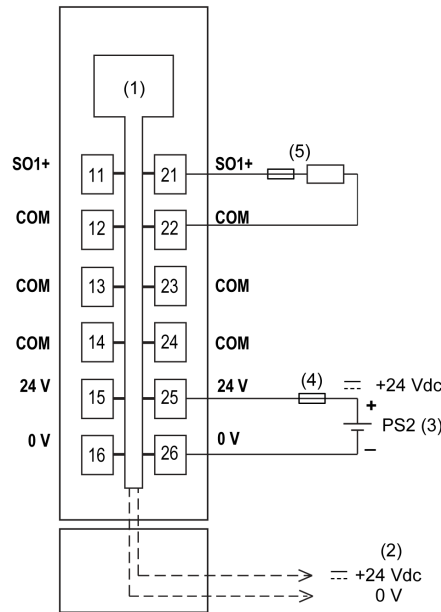

- 1 Internal electronics
- 2 24 Vdc I/O power segment integrated into the bus bases
- 3 PS2: External isolated power supply 24 Vdc
- 4 External fuse: 10 A maximum (6.3 A maximum UL), 250 V
- 5 TM5SPS1 or TM5SPS1F Power Distribution modules or actuator with current limited to fuse sized to the load: 10 A maximum (6.3 A maximum UL)

**⚠ WARNING**

**UNINTENDED EQUIPMENT OPERATION**

Do not connect wires to unused terminals and/or terminals indicated as “No Connection (N.C.)”.

**Failure to follow these instructions can result in death, serious injury, or equipment damage.**

**⚠ WARNING**

**UNINTENDED EQUIPMENT OPERATION**

Use the sensor and actuator power supply only for supplying power to sensors or actuators connected to the module.

**Failure to follow these instructions can result in death, serious injury, or equipment damage.**

---

# Appendices

## What's in This Part

TM5ACBM3FS Safety Bus Base .....	232
TM5ACBM4FS Safety Bus Base .....	235
TM5ACTB52FS Safety Terminal Block .....	238
TM5ACTB5EFS Safety Terminal Block .....	241
TM5ACTB5FFS Safety Terminal Block .....	243

# TM5ACBM3FS Safety Bus Base

## What's in This Chapter

TM5ACBM3FS Presentation ..... 232  
 TM5ACBM3FS Characteristics ..... 233  
 TM5ACBM3FS Wiring ..... 234

## TM5ACBM3FS Presentation

### Main Features

The TM5ACBM3FS is the Safety bus base for the TM5 Safety I/O modules.

The main features of the Safety bus base TM5ACBM3FS are:

- Safety bus base for TM5 Safety I/O modules (except the TM5SPS10FS Safety Power Distribution module)
- internal I/O supply is interconnected
- safety coded

### Ordering Information

The following figure presents the TM5ACBM3FS Safety bus base:

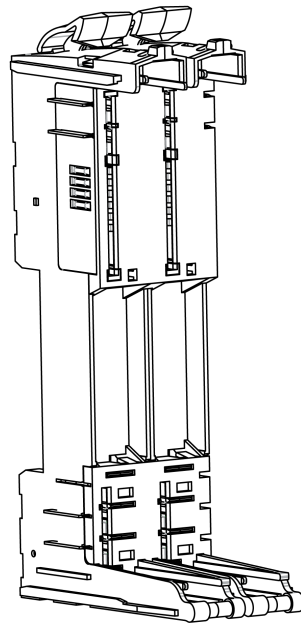

The following table presents the reference for the Safety bus base:

Reference	Description	Color
TM5ACBM3FS	TM5 Safety bus base, safety coded, internal I/O supply is interconnected	red



**⚠️ DANGER**

**HAZARD OF ELECTRIC SHOCK, EXPLOSION OR ARC FLASH**

- Disconnect all power from all equipment including connected devices prior to removing any covers or doors, or installing or removing any accessories, hardware, cables, or wires except under the specific conditions specified in the appropriate hardware guide for this equipment.
- Always use a properly rated voltage sensing device to confirm the power is off where and when indicated.
- Replace and secure all covers, accessories, hardware, cables, and wires and confirm that a proper ground connection exists before applying power to the unit.
- Use only the specified voltage when operating this equipment and any associated products.

**Failure to follow these instructions will result in death or serious injury.**

## TM5ACBM3FS Characteristics

### Introduction

This section describes the characteristics of the TM5ACBM3FS Safety bus base. See also TM5 Environmental Characteristics, page 26.

**⚠️ DANGER**

**FIRE HAZARD**

- Use only the correct wire sizes for the maximum current capacity of the I/O channels and power supplies.
- For relay output (2 A) wiring, use conductors of at least 0.5 mm<sup>2</sup> (AWG 20) with a temperature rating of at least 80 °C (176 °F).
- For common conductors of relay output wiring (4 A), or relay output wiring greater than 2 A, use conductors of at least 1.0 mm<sup>2</sup> (AWG 16) with a temperature rating of at least 80 °C (176 °F).

**Failure to follow these instructions will result in death or serious injury.**

**⚠️ WARNING**

**UNINTENDED EQUIPMENT OPERATION**

Do not exceed any of the rated values specified in the environmental and electrical characteristics tables.

**Failure to follow these instructions can result in death, serious injury, or equipment damage.**

### General Characteristics

The following table lists the general characteristics for the TM5ACBM3FS:

General characteristics		
Power consumption	bus	26 mA
	I/O internal	-
Certification	<ul style="list-style-type: none"> <li>• CE</li> <li>• UL508 (ULus)</li> </ul>	

## Operating Conditions

The following table lists the operating conditions for the TM5ACBM3FS:

Operating Conditions		
Mounting orientation		horizontal or vertical
Operating temperature (depending on the associated Safety I/O module)	horizontal installation	Generally: 0...+55 °C (+32...131 °F)
	vertical installation	Generally: 0...+50 °C (+32...122 °F)
Relative humidity		5...95%, non-condensing
Installation at altitudes above sea level:	0 up to 2000 m (0 up to 6561 ft)	no derating for altitude
	> 2000 m (>6561 ft)	reduction of ambient temperature by 0.5 °C per 100 m (32.9 °F per 328 ft)
Protection type		IP20

## Storage and Transport Conditions

The following table lists the storage and transport conditions for the TM5ACBM3FS:

Storage and Transport Conditions	
Temperature	-25...+70 °C (-13...+158 °F)
Relative humidity	5...95%, non-condensing

## TM5ACBM3FS Wiring

### Potential Control

The following figure presents the potential control of TM5ACBM3FS:

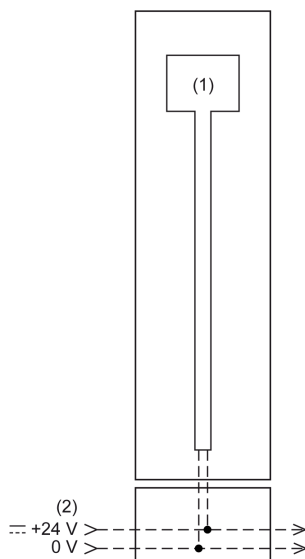

**1** Internal electronics

**2** 24 Vdc I/O power

# TM5ACBM4FS Safety Bus Base

## What's in This Chapter

TM5ACBM4FS Presentation ..... 235  
 TM5ACBM4FS Characteristics ..... 236  
 TM5ACBM4FS Wiring ..... 237

## TM5ACBM4FS Presentation

### Main Features

The TM5ACBM4FS is the Safety bus base for the TM5 Safety Power Distribution module.

The main features of the Safety bus base TM5ACBM4FS are:

- Safety bus base for the TM5 Safety Power Distribution module
- internal I/O supply is left isolated
- safety coded

### Ordering Information

The following figure presents the TM5ACBM4FS Safety bus base:

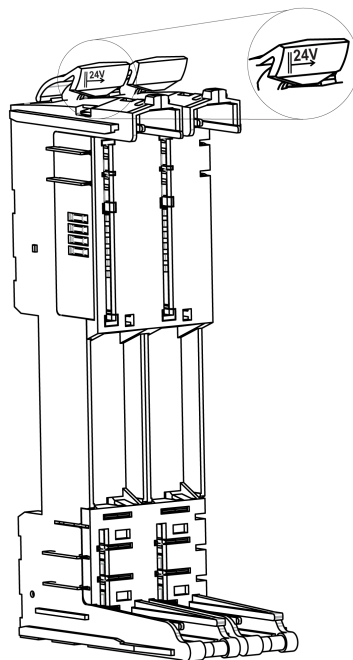

The following table presents the reference for the Safety bus base:

Reference	Description	Color
TM5ACBM4FS	TM5 Safety bus base, safety coded, internal I/O supply is left isolated	red

**⚡⚠ DANGER**

**HAZARD OF ELECTRIC SHOCK, EXPLOSION OR ARC FLASH**

- Disconnect all power from all equipment including connected devices prior to removing any covers or doors, or installing or removing any accessories, hardware, cables, or wires except under the specific conditions specified in the appropriate hardware guide for this equipment.
- Always use a properly rated voltage sensing device to confirm the power is off where and when indicated.
- Replace and secure all covers, accessories, hardware, cables, and wires and confirm that a proper ground connection exists before applying power to the unit.
- Use only the specified voltage when operating this equipment and any associated products.

**Failure to follow these instructions will result in death or serious injury.**

## TM5ACBM4FS Characteristics

### Introduction

This section describes the characteristics of the TM5ACBM4FS Safety bus base. See also TM5 Environmental Characteristics, page 26.

**⚠ DANGER**

**FIRE HAZARD**

Use only the correct wire sizes for the maximum current capacity of the I/O channels and power supplies.

**Failure to follow these instructions will result in death or serious injury.**

**⚠ WARNING**

**UNINTENDED EQUIPMENT OPERATION**

Do not exceed any of the rated values specified in the environmental and electrical characteristics tables.

**Failure to follow these instructions can result in death, serious injury, or equipment damage.**

### General Characteristics

The following table lists the general characteristics for the TM5ACBM4FS:

General characteristics		
Power consumption	bus	26 mA
	I/O internal	-
Certification		<ul style="list-style-type: none"> <li>• CE</li> <li>• cULus</li> <li>• cCSAus HazLoc Class 1 Division 2</li> </ul>

### Operating Conditions

The following table lists the operating conditions for the TM5ACBM4FS:

Operating conditions		
Mounting orientation		horizontal or vertical
Operating temperature	horizontal installation	See the TM5SPS10FS operating temperature.
	vertical installation	
Relative humidity		5...95%, non-condensing
Installation at altitudes above sea level:	0 up to 2000 m (0 up to 6561 ft)	no derating
	> 2000 m (>6561 ft)	reduction of ambient temperature by 0.5 °C per 100 m (32.9 °F per 328 ft)
Protection type		IP20

## Storage and Transport Conditions

The following table lists the storage and transport conditions for the TM5ACBM4FS:

Storage and transport conditions	
Temperature	-40...+85 °C (-40...+185 °F)
Relative humidity	5...95%, non-condensing

## TM5ACBM4FS Wiring

### Potential Control

The following figure presents the potential control of TM5ACBM4FS:

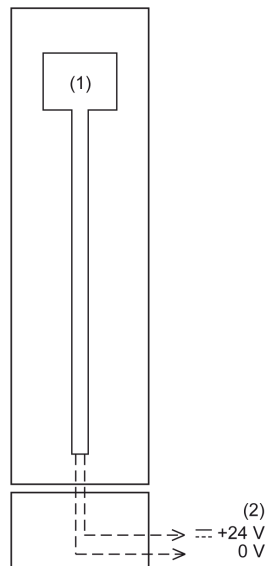

**1** Internal electronics

**2** 24 Vdc I/O power

**NOTE:** To identify the bus base type (voltage routing) being used even when an electronic module is inserted, the bus bases with I/O supply left isolated are identified by a marking on the upper locking lever (||-> **24V**).

# TM5ACTB52FS Safety Terminal Block

## What's in This Chapter

Safety Terminal Block Presentation..... 238

## Safety Terminal Block Presentation

### TM5ACTB52FS Features

The safety-related modules and the Safety Logic Controllers are wired by means of the TM5ACTB52FS Safety terminal block:

Features	
Type of terminal block	12-pin, safety coded terminal block
Features	<ul style="list-style-type: none"> <li>• tool-free wiring with push-in technology</li> <li>• simple wire release using lever</li> <li>• allows labeling of each terminal</li> <li>• allows plain text labeling</li> <li>• test access for standard probes</li> <li>• potential for customer coding</li> </ul>

### Ordering Information

The following figure presents the TM5ACTB52FS Safety terminal block:

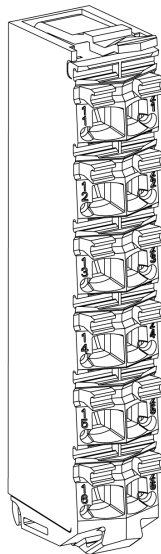

The following table presents the reference for the Safety terminal block:

Reference	Description	Color
TM5ACTB52FS	24 Vdc / 230 Vac, 12-pin terminal block for safety-related modules and Safety Logic Controllers, safety coded	red

**⚠️⚠️ DANGER**

**INCOMPATIBLE COMPONENTS CAUSE ELECTRIC SHOCK OR ARC FLASH**

- Do not associate components of a slice that have different colors.
- Verify that correct terminal blocks (minimally, matching colors and correct number of terminals) are installed on the appropriate electronic modules.

**Failure to follow these instructions will result in death or serious injury.**

**Characteristics**

This section describes the characteristics of the TM5ACTB52FS Safety terminal block, you can also refer to TM5 Environmental Characteristics, page 26.

**⚠️ DANGER**

**FIRE HAZARD**

- Use only the correct wire sizes for the maximum current capacity of the I/O channels and power supplies.
- For relay output (2 A) wiring, use conductors of at least 0.5 mm<sup>2</sup> (AWG 20) with a temperature rating of at least 80 °C (176 °F).
- For common conductors of relay output wiring (4 A), or relay output wiring greater than 2 A, use conductors of at least 1.0 mm<sup>2</sup> (AWG 16) with a temperature rating of at least 80 °C (176 °F).

**Failure to follow these instructions will result in death or serious injury.**

**⚠️ WARNING**

**UNINTENDED EQUIPMENT OPERATION**

Do not connect wires to unused terminals and/or terminals indicated as “No Connection (N.C.)”.

**Failure to follow these instructions can result in death, serious injury, or equipment damage.**

**⚠️ WARNING**

**UNINTENDED EQUIPMENT OPERATION**

Do not exceed any of the rated values specified in the characteristics tables.

**Failure to follow these instructions can result in death, serious injury, or equipment damage.**

The following table lists the characteristics of the TM5ACTB52FS:

Characteristics		
Type of terminal block		Push-in terminal block
Distance between contacts	left - right	4.2 mm / 0.16 in
	above - below	10.96 mm / 0.43 in
Contact resistance		≤ 5 mΩ
Maximum current carrying capacity of the connector		10 A / contact <b>NOTE:</b> The electrical characteristics of the individual modules must be respected.
Connection cross section	solid wire	0.08 mm <sup>2</sup> ... 2.5 mm <sup>2</sup> / AWG 28 ... 14
	multi-wire	0.25 mm <sup>2</sup> ... 2.5 mm <sup>2</sup> / AWG 24 ... 14
	with wire cable ends	0.25 mm <sup>2</sup> ... 1.5 mm <sup>2</sup> / AWG 24 ... 16

Characteristics		
	-	Up to 2x 0.75 mm <sup>2</sup> (AWG 2 x 24 ... 2 x 18) with double wire cable ends
Cable type		Copper wires only

 **DANGER****LOOSE WIRING CAUSES ELECTRIC SHOCK**

Do not insert more than one wire per connector of the spring terminal blocks unless using a double wire cable end (ferrule).

**Failure to follow these instructions will result in death or serious injury.**



# TM5ACTB5EFS Safety Terminal Block

## What's in This Chapter

Safety Terminal Block Presentation..... 241

## Safety Terminal Block Presentation

### TM5ACTB5EFS Features

Some TM5 Safety I/O modules are wired by using the TM5ACTB5EFS Safety terminal block:

Features	
Type of terminal block	16-pin, safety coded terminal block
Features	<ul style="list-style-type: none"> <li>• Tool-free wiring with push-in technology</li> <li>• Simple wire release using lever</li> <li>• Allows labeling of each terminal</li> <li>• Allows plain text labeling</li> <li>• Test access for standard probes</li> <li>• Potential for customer coding</li> <li>• 2x PT1000 integrated for terminal temperature compensation</li> </ul>

### Ordering Information

The following figure presents the TM5ACTB5EFS Safety terminal block:

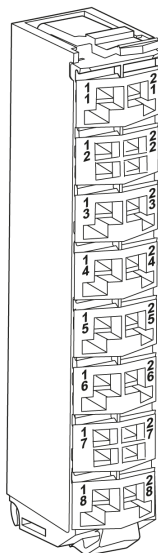

The following table presents the reference for the Safety terminal block:

Reference	Description	Color
TM5ACTB5EFS	TM5 Safety terminal block, 16-pin, safety coded, 2x PT1000 integrated for terminal temperature compensation	Red

**⚡⚠ DANGER**

**INCOMPATIBLE COMPONENTS CAUSE ELECTRIC SHOCK OR ARC FLASH**

- Do not associate components of a slice that have different colors.
- Verify that correct terminal blocks (minimally, matching colors and correct number of terminals) are installed on the appropriate electronic modules.

**Failure to follow these instructions will result in death or serious injury.**

**Characteristics**

This section describes the characteristics of the TM5ACTB5EFS Safety terminal block, you can also refer to TM5 Environmental Characteristics, page 26.

**⚠ DANGER**

**FIRE HAZARD**

Use only the correct wire sizes for the maximum current capacity of the I/O channels and power supplies.

**Failure to follow these instructions will result in death or serious injury.**

**⚠ WARNING**

**UNINTENDED EQUIPMENT OPERATION**

Do not exceed any of the rated values specified in the characteristics tables.

**Failure to follow these instructions can result in death, serious injury, or equipment damage.**

The following table lists the characteristics of the TM5ACTB5EFS terminal block:

Characteristics		
Type of terminal block	Push-in terminal block	
Terminal temperature compensation	2x PT1000 integrated for terminal temperature compensation	
Distance between contacts	Left - right	4.2 mm / 0.16 in
	Above - below	8.25 mm / 0.32 in
Contact resistance	≤ 5 mΩ	
Maximum current carrying capacity of the connector	2 A / contact <b>NOTE:</b> The electrical characteristics of the individual modules must be respected.	
Rated voltage	24 Vdc	
Maximum voltage	50 Vdc	
Connection cross section	Solid wire	0.08 mm <sup>2</sup> - 1.5 mm <sup>2</sup> / AWG 28 - 16
	Multi-wire	0.25 mm <sup>2</sup> - 1.5 mm <sup>2</sup> / AWG 24 - 16
	With wire cable ends	0.25 mm <sup>2</sup> - 0.75 mm <sup>2</sup> / AWG 24 - 20
Cable type	Copper wires only	

# TM5ACTB5FFS Safety Terminal Block

## What's in This Chapter

Safety Terminal Block Presentation..... 243

## Safety Terminal Block Presentation

### TM5ACTB5FFS Features

TM5STI4ATCFS Safety Analog Input module is wired by using the TM5ACTB5FFS Safety terminal block:

Features	
Type of terminal block	16-pin, safety coded terminal block
Features	<ul style="list-style-type: none"> <li>• Tool-free wiring with push-in technology</li> <li>• Simple wire release using lever</li> <li>• Allows labeling of each terminal</li> <li>• Allows plain text labeling</li> <li>• Test access for standard probes</li> <li>• Potential for customer coding</li> </ul>

### Ordering Information

The following figure presents the TM5ACTB5FFS Safety terminal block:

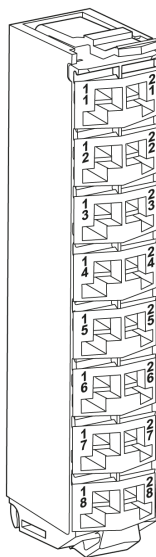

The following table presents the reference for the Safety terminal block:

Reference	Description	Color
TM5ACTB5FFS	TM5 Safety terminal block, 16-pin, safety coded	Red

## ⚠️ ⚠️ DANGER

**INCOMPATIBLE COMPONENTS CAUSE ELECTRIC SHOCK OR ARC FLASH**

- Do not associate components of a slice that have different colors.
- Verify that correct terminal blocks (minimally, matching colors and correct number of terminals) are installed on the appropriate electronic modules.

**Failure to follow these instructions will result in death or serious injury.**

## Characteristics

This section describes the characteristics of the TM5ACTB5FFS Safety terminal block, you can also refer to TM5 Environmental Characteristics, page 26.

### ⚠ DANGER

#### FIRE HAZARD

Use only the correct wire sizes for the maximum current capacity of the I/O channels and power supplies.

**Failure to follow these instructions will result in death or serious injury.**

### ⚠ WARNING

#### UNINTENDED EQUIPMENT OPERATION

Do not exceed any of the rated values specified in the characteristics tables.

**Failure to follow these instructions can result in death, serious injury, or equipment damage.**

The following table lists the characteristics of the TM5ACTB5FFS:

Characteristics		
Type of terminal block		Push-in terminal block
Distance between contacts	Left - right	4.2 mm / 0.16 in
	Above - below	8.25 mm / 0.32 in
Contact resistance		≤ 5 mΩ
Maximum current carrying capacity of the connector		2 A / contact <b>NOTE:</b> The electrical characteristics of the modules must be respected.
Rated voltage		24 Vdc
Maximum voltage		50 Vdc
Connection cross section	Solid wire	0.08 mm <sup>2</sup> - 1.5 mm <sup>2</sup> / AWG 28 - 16
	Multi-wire	0.25 mm <sup>2</sup> - 1.5 mm <sup>2</sup> / AWG 24 - 16
	With wire cable ends	0.25 mm <sup>2</sup> - 0.75 mm <sup>2</sup> / AWG 24 - 20
Cable type		Copper wires only

# Glossary

## B

### bus base:

A bus base is a mounting device that is designed to seat an electronic module on a DIN rail and connect it to the TM5 bus for Safe Logic Controllers. Each bus base extends the TM5 data and the power buses and the 24 Vdc I/O power segment. The electronic modules are added to the TM5 system through their insertion on the base bus. The bus base also supplies the articulation point for the terminal blocks.

## C

### controller:

A controller (or “programmable logic controller”, or “programmable controller”) is used to automate industrial processes.

## D

### DC:

diagnostic coverage

Fractional decrease in the probability of dangerous hardware failures resulting from the operation of the automatic diagnostic tests

(definition IEC 61508)

The fraction of the possible dangerous failures  $\lambda_D$  is divided into failures which are detected by diagnostics and failures which remain undetected.

$$\lambda_D = \lambda_{DD} + \lambda_{DU}$$

The diagnostic coverage (DC) defines the fraction of the dangerous failures which are detected.

$$\lambda_{DD} = \lambda_D \cdot DC$$

$$\lambda_{DU} = \lambda_D \cdot (1 - DC)$$

The definition may also be represented in terms of the following equation, where DC is the diagnostic coverage,  $\lambda_{DD}$  is the probability of detected dangerous failures and  $\lambda_D$  total is the probability of total dangerous failures:

$$DC = \frac{\sum \lambda_{DD}}{\sum \lambda_{Dtotal}}$$

## E

### EN ISO 13849:

European Standard that addresses the functional safety of controller parts.

### EN:

EN identifies one of many European standards maintained by CEN (European Committee for Standardization), CENELEC (European Committee for Electrotechnical Standardization), or ETSI (European Telecommunications Standards Institute).

## I

### IEC 61508:

The IEC 61508 standard is an international standard that addresses functional safety of electrical / electronic / programmable electronic safety-related systems.

It applies to any kind of Safety-Related System in any industry wherever there are no product standards.

**IEC 62061:**

The IEC 62061 standard is an international standard that addresses functional safety of safety-related electrical, electronic, programmable electronic controller systems.

**IEC:**

International Electrotechnical Commission

**IP 20:**

Ingress protection rating according to IEC 60529. IP20 modules are protected against ingress and contact of objects larger than 12.5 mm (0.49 inches). The module is not protected against harmful ingress of water.

**IP 67:**

Ingress protection rating according to IEC 60529. IP67 modules are completely protected against ingress of dust and contact. Ingress of water in harmful quantity is not possible when the enclosure is immersed in water up to 1 m (3.28 ft.)

## M

**minimum cycle time:**

The minimum cycle time specifies the time up to which the bus cycle can be reduced without communication errors being detected.

**minimum I/O update time (maximum I/O update time):**

The I/O update time specifies the time needed by the module to generate a sample.

**MTTFd:**

mean time to failure - dangerous

## P

**PFD:**

probability of failure on demand

(definition IEC 61508)

For a single channel system the average probability of a failure on demand is calculated as follows:

$$\text{PFD}(t)_{AV} = \frac{1}{2} \lambda_{DU} \cdot t$$

For a dual channel system the average probability of a failure on demand is calculated as follows:

$$\text{PFD}(t)_{AV} = \lambda_{DUCH1} \cdot \lambda_{DUCH2} \cdot t^2 + CC$$

For a dual channel system, also the Common Cause effect (CC) must be considered. The common cause effect ranges from 1% to 10% of PFD<sub>CH1</sub> and PFD<sub>CH2</sub> (=1/RRF).

**PFH:**

probability of dangerous failure per hour

(definition IEC 61508)

**PT:**

proof test interval

**S**

**SFF:**

safe failure fraction

**T**

**terminal block:**

The terminal block is the component that mounts in an electronic module and provides electrical connections between the controller and the field devices.

**U**

**UL:**

underwriters laboratories, US organization for product testing and safety certification





# Index

## C

certification	
TM5ACBM3FS	233, 238
TM5ACBM4FS	236
certifications and standards	
TM5SAI4AFS	186
TM5SDC1FS	208
TM5SDI20DFS	86
TM5SDI2DFS	71
TM5SDI4DFS	79
TM5SDM4DTRFS	154
TM5SDM8TBFS	164
TM5SDO2DTRFS	120
TM5SDO2TAFS	113
TM5SDO2TFS	106
TM5SDO4TAFS	137
TM5SDO4TFS	129
TM5SDO6TBFS	145
TM5SPS10FS	225
TM5STI4ATCFS	196
TM7SDI8DFS	95
TM7SDM12DTFS	174
characteristics	
TM5ACBM3FS	233, 238
TM5ACBM4FS	236
TM5ACTB5EFS	241
TM5ACTB5FFS	243
TM5SAI4AFS	186
TM5SDC1FS	208
TM5SDI20DFS	86
TM5SDI2DFS	71
TM5SDI4DFS	79
TM5SDM4DTRFS	154
TM5SDM8TBFS	164
TM5SDO2DTRFS	120
TM5SDO2TAFS	113
TM5SDO2TFS	106
TM5SDO4TAFS	137
TM5SDO4TFS	129
TM5SDO6TBFS	145
TM5SPS10FS	225
TM5STI4ATCFS	196
TM7SDI8DFS	95
TM7SDM12DTFS	174
connection example	
TM5SAI4AFS	190
TM5SDC1FS	212
TM5SDI20DFS	90
TM5SDI2DFS	75
TM5SDI4DFS	83
TM5SDM4DTRFS	160
TM5SDM8TBFS	169
TM5SDO2DTRFS	125
TM5SDO2TAFS	117
TM5SDO2TFS	109
TM5SDO4TAFS	141
TM5SDO4TFS	132
TM5SDO6TBFS	149
TM5SPS10FS	230
TM5STI4ATCFS	201
TM7SDI8DFS	99
TM7SDM12DTFS	179

## E

Electronic modules	
documentation references	29
installation	29
environmental characteristics	26

## F

function mode examples	
TM5SDC1FS	212

## I

IEC 61508	
defined safe state	16
Emergency Shutdown (ESD)	16
ESD (Emergency Shutdown)	16
Safety Integrity Level (SIL)	16
SIL (Safety Integrity Level)	16
IEC61508	
Functional Safety	16
input characteristics	
TM5SDC1FS	208
TM5SDI20DFS	86
TM5SDI2DFS	71
TM5SDI4DFS	79
installation	
dimensions	37
installation requirements	23
intended use	8

## L

LED indicators	
TM5SAI4AFS	183
TM5SDC1FS	205
TM5SDI20DFS	84
TM5SDI2DFS	68
TM5SDI4DFS	76
TM5SDM4DTRFS	151
TM5SDM8TBFS	161
TM5SDO2ATFS	110
TM5SDO2DTRFS	118
TM5SDO2TFS	103
TM5SDO4TAFS	134
TM5SDO4TFS	126
TM5SDO6TBFS	142
TM5SPS10FS	219
TM5STI4ATCFS	193
TM7SDI8DFS	92
TM7SDM12DTFS	170

## O

operating conditions	
TM5ACBM3FS	233, 238
TM5ACBM4FS	236
TM5SAI4AFS	186
TM5SDC1FS	208
TM5SDI20DFS	86
TM5SDI2DFS	71
TM5SDI4DFS	79
TM5SDM4DTRFS	154
TM5SDM8TBFS	164
TM5SDO2DTRFS	120
TM5SDO2TAFS	113
TM5SDO2TFS	106

TM5SDO4TAFS.....	137	power consumption	
TM5SDO4TFS.....	129	TM5ACBM3FS.....	233, 238
TM5SDO6TBFS.....	145	TM5ACBM4FS.....	236
TM5SPS10FS.....	225	TM5SAI4AFS.....	186
TM5STI4ATCFS.....	196	TM5SDC1FS.....	208
TM7SDI8DFS.....	95	TM5SDI20DFS.....	86
TM7SDM12DTFS.....	174	TM5SDI2DFS.....	71
ordering information		TM5SDI4DFS.....	79
TM5SAI4AFS.....	183	TM5SDM4DTRFS.....	154
TM5SDC1FS.....	205	TM5SDM8TBFS.....	164
TM5SDI20DFS.....	84	TM5SDO2DTRFS.....	120
TM5SDI2DFS.....	68	TM5SDO2TAFS.....	113
TM5SDI4DFS.....	76	TM5SDO2TFS.....	106
TM5SDM4DTRFS.....	151	TM5SDO4TAFS.....	137
TM5SDM8TBFS.....	161	TM5SDO4TFS.....	129
TM5SDO2DTRFS.....	118	TM5SDO6TBFS.....	145
TM5SDO2TAFS.....	110	TM5SPS10FS.....	225
TM5SDO2TFS.....	103	TM5STI4ATCFS.....	196
TM5SDO4TAFS.....	134	TM7SDI8DFS.....	95
TM5SDO4TFS.....	126	TM7SDM12DTFS.....	174
TM5SDO6TBFS.....	142	power supply voltage	
TM5SPS10FS.....	219	TM5SAI4AFS.....	186
TM5STI4ATCFS.....	193	TM5SDC1FS.....	208
TM7SDI8DFS.....	92	TM5SDI20DFS.....	86
TM7SDM12DTFS.....	170	TM5SDI2DFS.....	71
output characteristics		TM5SDI4DFS.....	79
TM5SAI4AFS.....	186	TM5SDM4DTRFS.....	154
TM5SDC1FS.....	208	TM5SDM8TBFS.....	164
TM5SDI20DFS.....	86	TM5SDO2DTRFS.....	120
TM5SDI2DFS.....	71	TM5SDO2TAFS.....	113
TM5SDI4DFS.....	79	TM5SDO2TFS.....	106
TM5SDM4DTRFS.....	154	TM5SDO4TAFS.....	137
TM5SDM8TBFS.....	164	TM5SDO4TFS.....	129
TM5SDO2DTRFS.....	120	TM5SDO6TBFS.....	145
TM5SDO2TAFS.....	113	TM5SPS10FS.....	225
TM5SDO2TFS.....	106	TM5STI4ATCFS.....	196
TM5SDO4TAFS.....	137	TM7SDI8DFS.....	95
TM5SDO4TFS.....	129	TM7SDM12DTFS.....	174
TM5SDO6TBFS.....	145	probability of failure on demand (PFD).....	18
TM5SPS10FS.....	225	probability of failure per hour (PFH).....	18
TM5STI4ATCFS.....	196		
TM7SDI8DFS.....	95		
TM7SDM12DTFS.....	174		
		<b>Q</b>	
		qualification of personnel.....	7
		<b>P</b>	
PFD (probability of failure on demand).....	18		
PFH (probability of failure per hour).....	18		
pin assignments		<b>S</b>	
TM5SAI4AFS.....	190	safety-related characteristics	
TM5SDC1FS.....	212	TM5SAI4AFS.....	186
TM5SDI20DFS.....	90	TM5SDC1FS.....	208
TM5SDI2DFS.....	75	TM5SDI20DFS.....	86
TM5SDI4DFS.....	83	TM5SDI2DFS.....	71
TM5SDM4DTRFS.....	160	TM5SDI4DFS.....	79
TM5SDM8TBFS.....	169	TM5SDM4DTRFS.....	154
TM5SDO2DTRFS.....	125	TM5SDM8TBFS.....	164
TM5SDO2TAFS.....	117	TM5SDO2DTRFS.....	120
TM5SDO2TFS.....	109	TM5SDO2TAFS.....	113
TM5SDO4TAFS.....	141	TM5SDO2TFS.....	106
TM5SDO4TFS.....	132	TM5SDO4TAFS.....	137
TM5SDO6TBFS.....	149	TM5SDO4TFS.....	129
TM5SPS10FS.....	230	TM5SDO6TBFS.....	145
TM5STI4ATCFS.....	201	TM5SPS10FS.....	225
TM7SDI8DFS.....	99	TM5STI4ATCFS.....	196
TM7SDM12DTFS.....	179	TM7SDI8DFS.....	95
potential control		TM7SDM12DTFS.....	174
TM5ACBM3FS.....	234	storage conditions	
TM5ACBM4FS.....	237	TM5ACBM3FS.....	233, 238
		TM5ACBM4FS.....	236

TM5SAI4AFS .....	186	TM5SDO4TFS.....	132
TM5SDC1FS .....	208	TM5SDO6TBFS .....	149
TM5SDI20DFS .....	86	TM5SPS10FS .....	230
TM5SDI2DFS .....	71	TM5STI4ATCFS .....	201
TM5SDI4DFS .....	79	TM7SDI8DFS .....	99
TM5SDM4DTRFS.....	154	TM7SDM12DTFS .....	179
TM5SDM8TBFS .....	164	wiring best practices .....	19
TM5SDO2DTRFS.....	120		
TM5SDO2TAFS.....	113		
TM5SDO2TFS.....	106		
TM5SDO4TAFS.....	137		
TM5SDO4TFS.....	129		
TM5SDO6TBFS .....	145		
TM5SPS10FS .....	225		
TM5STI4ATCFS .....	196		
TM7SDI8DFS .....	95		
TM7SDM12DTFS .....	174		

## T

TM5ACBM3FS.....	68, 76, 84, 103, 110, 126, 134, 142, 151, 161, 170, 183, 193, 205, 232
TM5ACBM4FS.....	219, 235
TM5ACTB52FS.....	68, 76, 84, 103, 110, 126, 134, 142, 151, 170, 205, 219, 232
safety terminal block.....	238
TM5ACTB5EFS	
safety terminal block.....	241
TM5ACTB5FFS .....	161, 183, 193
safety terminal block.....	243
TM7SDI8DFS .....	92
transport conditions	
TM5ACBM3FS .....	233, 238
TM5ACBM4FS .....	236
TM5SAI4AFS .....	186
TM5SDC1FS .....	208
TM5SDI20DFS .....	86
TM5SDI2DFS .....	71
TM5SDI4DFS .....	79
TM5SDM4DTRFS.....	154
TM5SDM8TBFS .....	164
TM5SDO2DTRFS.....	120
TM5SDO2TAFS.....	113
TM5SDO2TFS.....	106
TM5SDO4TAFS.....	137
TM5SDO4TFS.....	129
TM5SDO6TBFS .....	145
TM5SPS10FS .....	225
TM5STI4ATCFS .....	196
TM7SDI8DFS .....	95
TM7SDM12DTFS .....	174

## W

wiring	
TM5ACBM3FS .....	234
TM5ACBM4FS .....	237
TM5SAI4AFS .....	190
TM5SDC1FS .....	212
TM5SDI20DFS .....	90
TM5SDI2DFS .....	75
TM5SDI4DFS .....	83
TM5SDM4DTRFS.....	160
TM5SDM8TBFS .....	169
TM5SDO2DTRFS.....	125
TM5SDO2TAFS.....	117
TM5SDO2TFS.....	109
TM5SDO4TAFS.....	141

Schneider Electric  
35 rue Joseph Monier  
92500 Rueil Malmaison  
France

+ 33 (0) 1 41 29 70 00

[www.se.com](http://www.se.com)

As standards, specifications, and design change from time to time,  
please ask for confirmation of the information given in this publication.

© 2021 – Schneider Electric. All rights reserved.

EIO0000000861.08