



## Sink Triplo Invaso Workstation - 1491 059 Undermount

Kitchen Sinks

Code: 1491 059



### DETAILS

Finish	Foster brushed
Material	AISI 304 stainless steel
Texture	Foster brushed
Base	80 cm
Edge/Installation Type	Undermount
Dimensions	835x515 mm
Standard fittings	Fixing hooks, gasket, drain, overflow and siphon, boxed packing
Mixer holes	3 standard holes
Built-in hole	View technical data sheet (for all Flush-mount / Top-mount models and Under-mount models)

Drainer	No
Width	84 cm
Bowl dimension	710x400mm
Number of bowls	1 bowl
Waste fitting	Drain with automatic control SPACE (PUSH)

## EQUIPMENT

1 x Eclipse mixer tap 8499 000  
2 x Black grid 8100 603  
1 x Space Push automatic  
waste fitting 8407 116

## FEATURES

Automatic waste fitting	The waste-fitting with round remote knob is supplied; a practical accessory which makes it unnecessary to get wet in order to drain the water from the bowl.
Deep bowls	This bowls reach an important depth, over 20 cm, thanks to the advanced production technology, that can be offer great capieny and practicity in all the washing operations.
Perimetral overflow	The overflow is always a security on the Foster sinks that prevents the overflow of water in case of oversights. The perimeter drain solution improves aesthetics thanks to its square and essential shape.
Small radius	Bowls with squared shapes with a modern design and an increased capacity, for a minimal aesthetics connected with an extreme practicity.
Space waste fitting	The elegant SPACE steel cap closes the drain and leaves no visible residues collected in the basket below. Space also has a small footprint and allows the optimal use of the under-sink compartment.

## three-step system

An ingenious design that makes it simple to use a large set of optional accessories. On the topmost supporting step, the innovative Black grids slide, creating a large and practical surface to rinse food and crockery. The second step is meant to support and allow the sliding of a complete combination of accessories, which make some operations practical and safe: rinse, drain, slice, grate... everything can be done inside the sink. The new Black grids strongly characterize aesthetics and functionality. Hygienic, with great lightness, resistance and ease of cleaning, they are also 100% ecological, a respectful choice for nature and the environment that surrounds us.

## TECHNICAL DATA

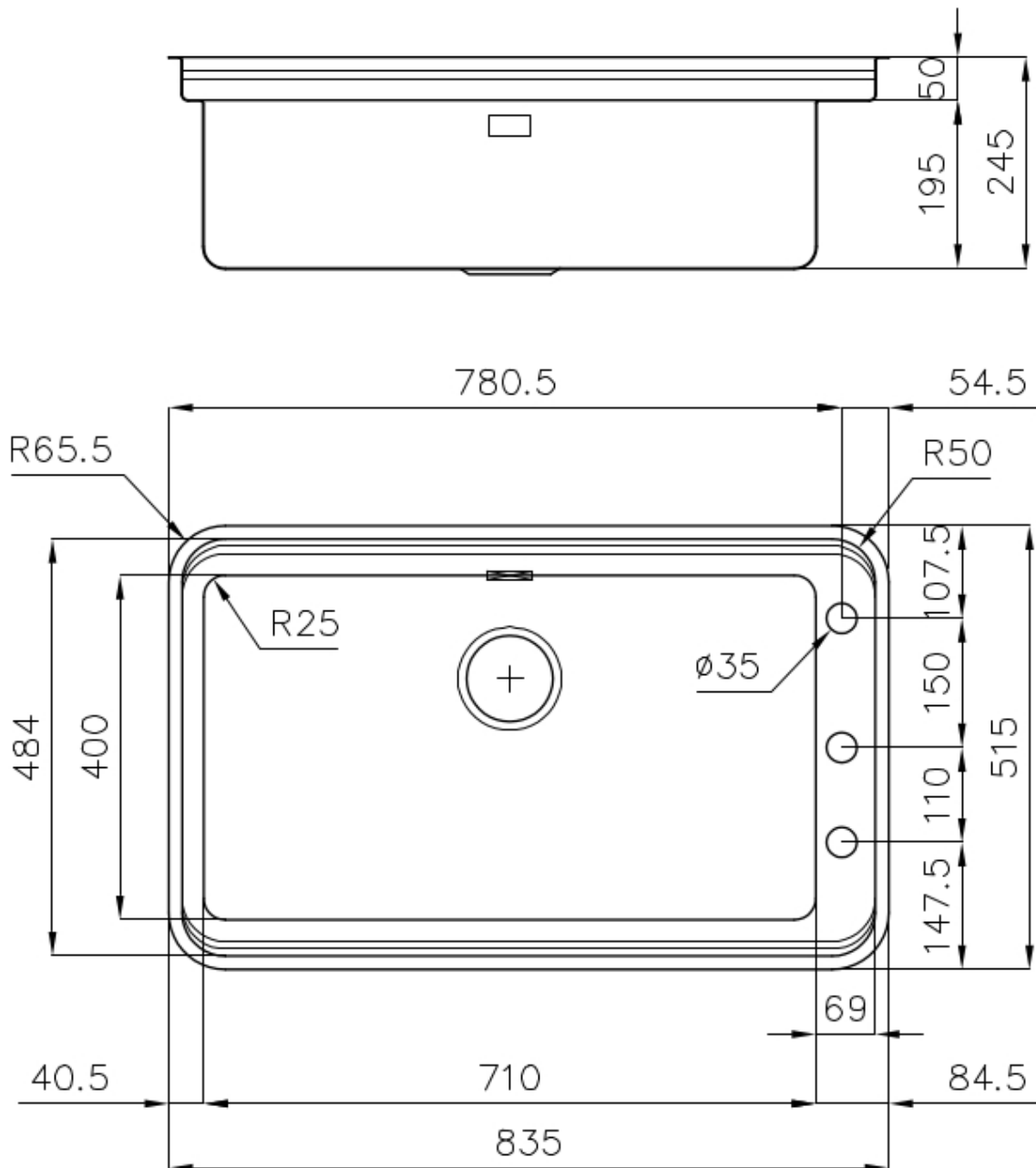

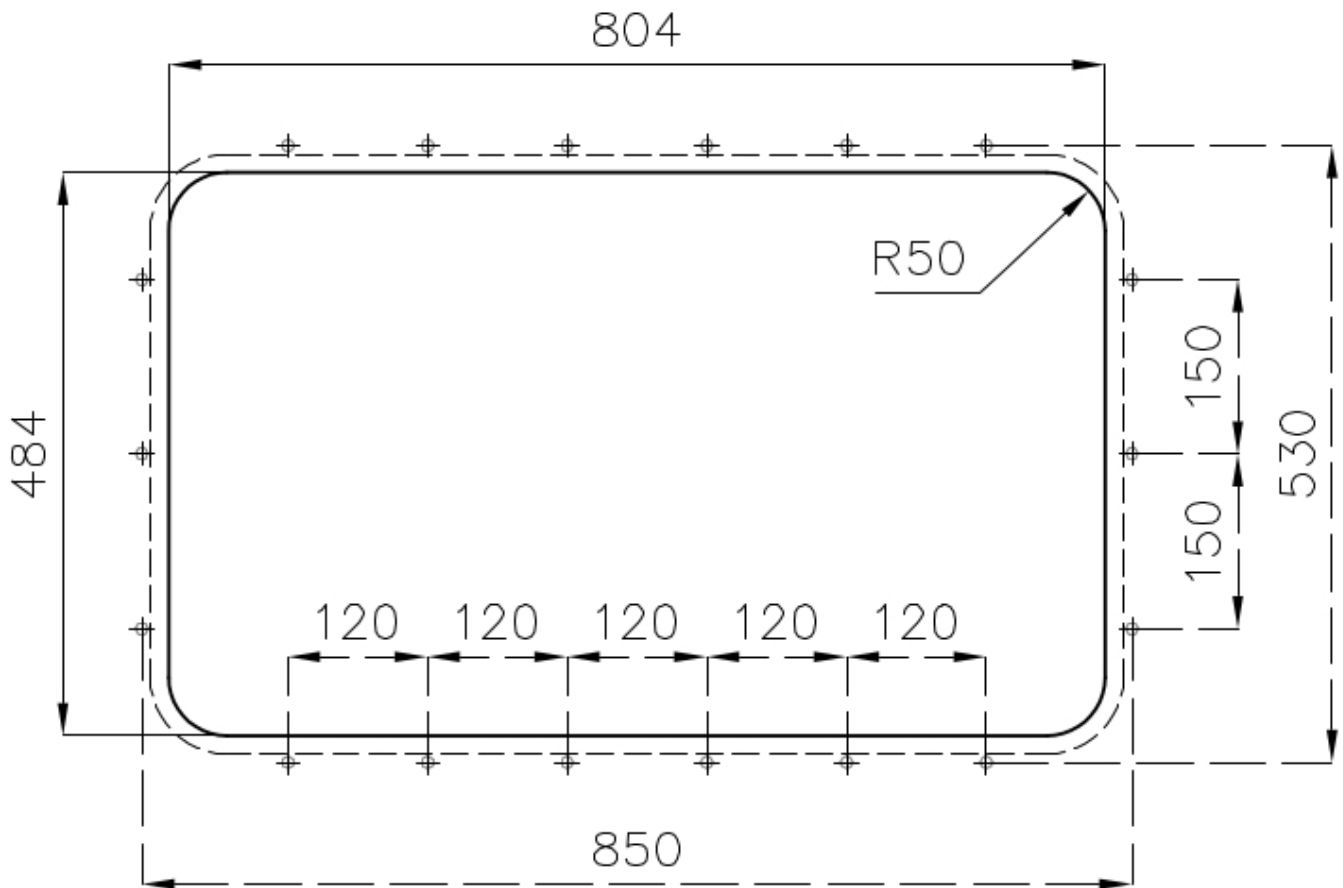

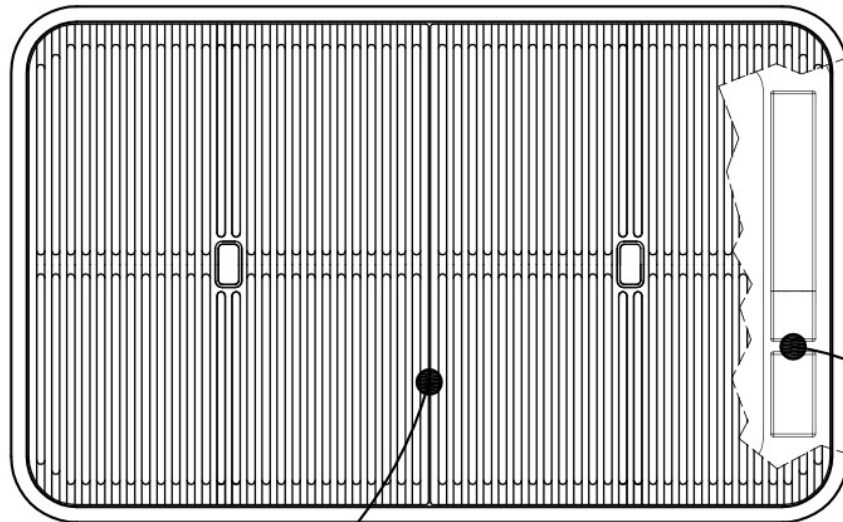
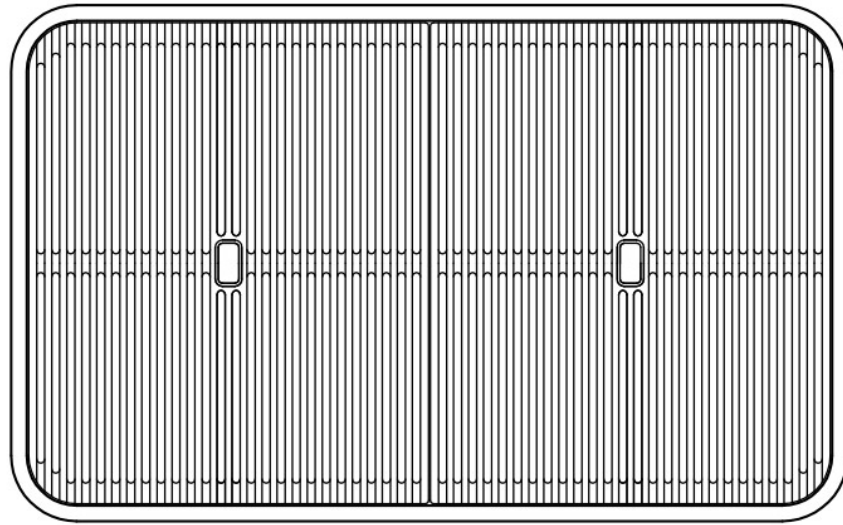

8100 603

**Grid  
Griglia  
x2**

8499 000

**Mixer tap  
Miscelatore**

## GALLERY



## EQUIPMENT



Mixer Tap Eclipse 8499 000



Space Push automatic waste fitting 8407 116



Black grid - 8100 603

## OPTIONAL ACCESSORIES



Cestello inox 8612 000



Glass chopping board 8631 300



HPDE Chopping board 8657 001



Iroko-wood chopping board 8643 115



Stainless steel plate rack 8100 115



White bowl 8153 100