

E22FT70



Collection: CONTRA

Finish*:



GA - Profiles chromés

Main features:



Features

- DIMENSIONS: 200 x 70 cm
- MATERIAL: Clear glass
- GLASS THICKNESS IN MM: 6
- WALL ADJUSTMENT IN MM: 20 mm
- INSTALLATION: Close Space
- OPTIONAL: Fixed return 30 cm
- ADAPTABILITY: To install a Contra pivot corner enclosure
- WEIGHT: 28 kg
- INSTALLATION TYPE: Fixed panel
- PANEL HEIGHT IN CM: 200
- ENCLOSURE TYPE: Walk-in
- ANTI-SCALE TREATMENT: Yes
- SAFETY: 6 mm clear coated glass

Consumer benefits

- ESTHETIC: Pared-down frameless panel; polished chrome profile with upper caps
- EASY CARE: Coated glass on the inside; caps, smooth surface (concealed hardware)

Installation benefits

- EASY ASSEMBLY: 20 mm wall adjustment for out-of-plumb walls

Required products

- E22BW90: Horizontal bar
- E22BWC: Vertical ceiling-mounted bar
- E22BT: ff

Technical drawing

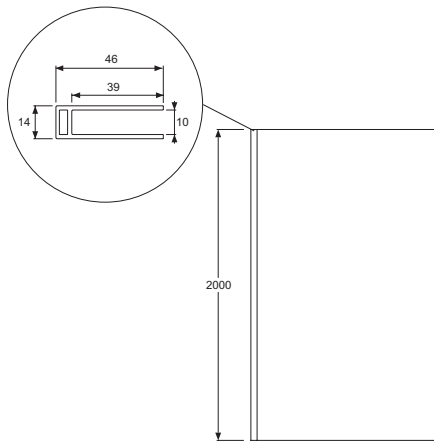

	E22FT70	E22FT80	E22W90	E22W100	E22W110	E22W120	E22W130	E22W140
Mm	700	800	900	1000	1100	1200	1300	1400
A mini/maxi	650 / 685	750 / 785	870 / 890	970 / 990	1070 / 1090	1170 / 1190	1270 / 1290	1370 / 1390

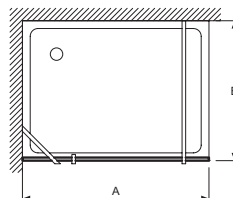

Product Specification: Side panel 70 cm. E22FT70. Collection: CONTRA. DIMENSIONS: 200 x 70 cm. WEIGHT: 28 kg. MATERIAL: Clear glass. INSTALLATION TYPE: Fixed panel. GLASS THICKNESS IN MM: 6. PANEL HEIGHT IN CM: 200. WALL ADJUSTMENT IN MM: 20 mm. ENCLOSURE TYPE: Walk-in. INSTALLATION: Close Space. ANTI-SCALE TREATMENT: Yes. OPTIONAL: Fixed return 30 cm. SAFETY: 6 mm clear coated glass. ADAPTABILITY: To install a Contra pivot corner enclosure.

*Due to possible variations in computer and printer calibrations, technical factors and certain finish characteristics, the colors you see may not accurately portray the actual colors and are provided as a guide only.