

E4345



Collection: BRIVE

Finish*:



00 - White

Main features:



Features

- **DIMENSIONS:** 52 x 36 cm
- **MATERIAL:** Ceramic
- **VOLUME OF WATER:** 2.6/4 L and 3/6 L
- **RIM TYPE:** Open (traditional)
- Semi-skirted bowl
- **WEIGHT:** 14.5 kg
- **INSTALLATION TYPE:** Wall-hung
- **HEIGHT:** Standard
- **RIM:** With rim

Consumer benefits

- **ECONOMICAL:** Especially designed to be water efficient (2.6/4 L)
- **EASY CARE:** Smooth trapway for added hygiene

Technical drawing

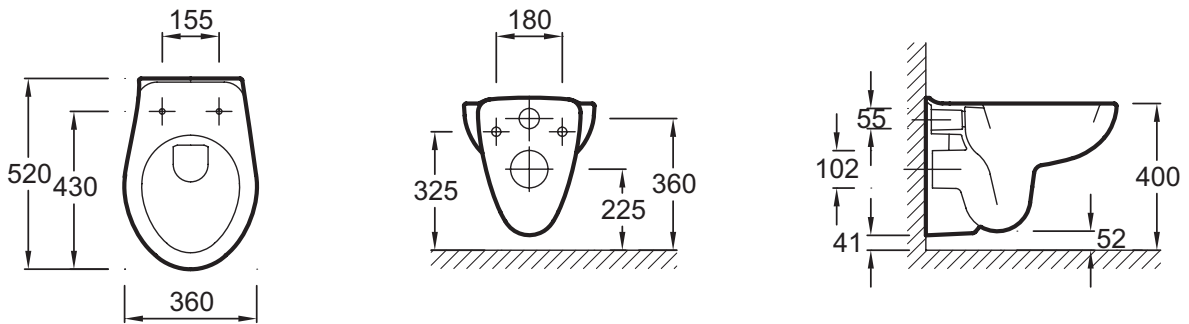

Product Specification: Wall-hung WC pan. E4345. Collection: BRIVE. DIMENSIONS: 52 x 36 cm. WEIGHT: 14.5 kg. MATERIAL: Ceramic. INSTALLATION TYPE: Wall-hung. VOLUME OF WATER: 2.6/4 L and 3/6 L. HEIGHT: Standard. RIM TYPE: Open (traditional). RIM: With rim. Semi-skirted bowl.

**Due to possible variations in computer and printer calibrations, technical factors and certain finish characteristics, the colors you see may not accurately portray the actual colors and are provided as a guide only.*