

EB1735D



Collection: TERRACE

Finish\*:



NF - Neutral

Main features:



### Features

- DIMENSIONS: 60 x 13 x 68.50 cm
- MATERIAL: Solid wood
- POWER: 230V, 7, 2W, classe II IP44
- USB SOCKET: Yes
- VERSION: Right

- WEIGHT: 10 kg
- INSTALLATION TYPE: Wall-mount
- ELECTRICAL OUTLET: Yes
- SHELF: Yes
- TEMPERATURE: 4000°K

### Consumer benefits

- UNIQUE DESIGN: Elegant, precise, rectangular geometry specific to contemporary design.
- PRACTICAL: LED lighting with detection switch when the drawer opens
- PERFECT FINISH: Lacquered finish for accessories drawer.
- INGENIOUS: 1 outlet and an USB connection inside the cabinet to plug in daily accessories

### Installation benefits

- EASY INSTALLATION: Assembled cabinet

### Technical drawing

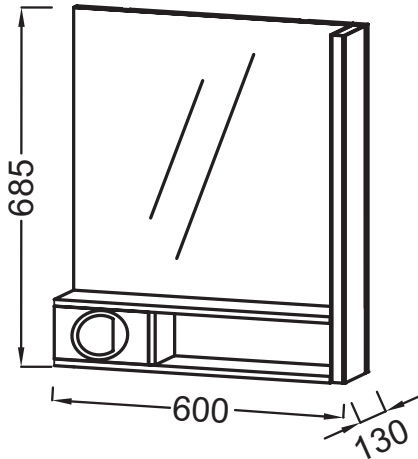

Product Specification: Premium mirror 60 cm, RH lighting. EB1735D. Collection: TERRACE. DIMENSIONS: 60 x 13 x 68.50 cm. WEIGHT: 10 kg. MATERIAL: Solid wood. INSTALLATION TYPE: Wall-mount. POWER: 230V, 7, 2W, classe II IP44. ELECTRICAL OUTLET: Yes. USB SOCKET: Yes. SHELF: Yes. VERSION: Right. TEMPERATURE: 4000°K.