

LED SUSPENSION LIGHT

Product&Family Code:

019
015
0035
COSTA-35

Technical Data

Voltage (V)	220-240
Product Wattage (W)	35
Equivalence with incandescent lamp(W)	280
Colour Render Index (Ra)	>Ra80
Colour Temperature (K)	4000K
Materials	Aluminium + Iron + Acrylic
Protection Class	I
Dimmable	No
EEL	A to A++
Warm-up time up to 60 % of the full light output	Instant Full Light
Luminous Flux (lm)	2000
Luminous Efficacy (lm/W)	57
Rated Life (hrs) ⌚	50.000
IP Rating	20
Power Factor	>0.9
Beam Angle	120°

BLACK
WHITE

Technical Drawing

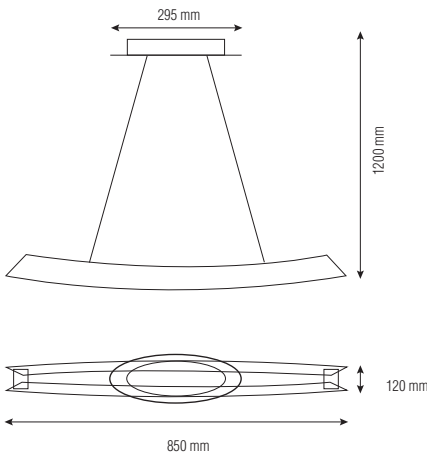

Photometric Diagram

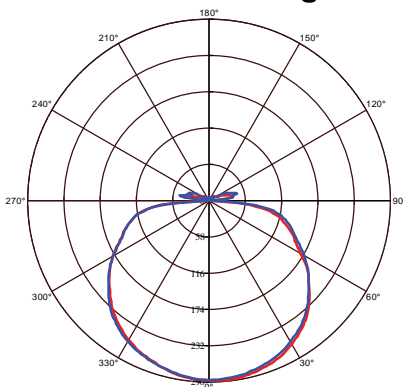

C0 Plane beam angle(50%):137.3(DEG)
C90 Plane beam angle(50%):138.8(DEG)

Applications

- LED Suspension Light has been specifically designed for use indoors and is ideal for both hospitality and residential lighting.



Features

- High Lumen and CRI, Good quality & Constant Current driver.
- High heat dissipation, low carbon and environmental protection.
- SMD LED Lamp Base
- Very low energy consumption

