

Freja Bar Stool SH750 Leather Stripe Seat

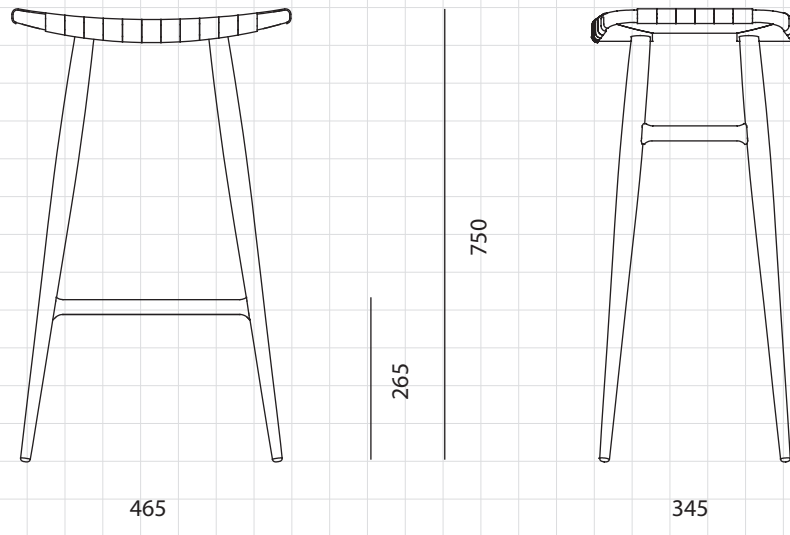

CODE

FE-S320-LS

DIMENSIONS

W465 x D345 x H750mm

NET WEIGHT

3.6 kg

ENVIRONMENT

Indoor

MATERIALS

Solid wood frame, Leather seat

*Please refer to website or contact your local representative for complete material swatches.

SHIPPING

Package	Assembled		
Package Qty	1 pcs/box		
Packaging	Measurement (mm)	Volume (cbm)	Gross Weight (kg)
FCL	W530 x D410 x H835	0.18	7.85
LCL/AIR	W570 x D450 x H925	0.24	10.83