

**ENN90**



**Collection:** KYREO

**Finish\*:**



00 - Blanc

**Main features:**



**Features**

- DIMENSIONS: 100 x 70 x 4 cm
- MATERIAL: Ceramic
- NORMS AND REGULATION: NF
- WASTE DIAMETER: 9
- ADHERENCE: PN6
- 10-year warranty
- WEIGHT: 27.4 kg
- INSTALLATION TYPE: Floorstanding or inset
- SHAPE: Rectangular
- SURFACE PATTERN: Smooth
- WASTE SUPPLIED: No

**Consumer benefits**

- STREAMLINED DESIGN AND ACCESSIBILITY: Smooth, extra-slim shower tray 4 cm high
- EXCEPTIONAL LONGEVITY: Glazed enamel

**Installation benefits**

- EASE OF INSTALLATION: Ledge around tray allows for installation of any shower enclosure
- 2 INSTALLATION OPTIONS: Floorstanding or inset, height 4 cm.

**Technical drawing**

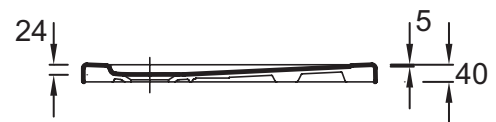
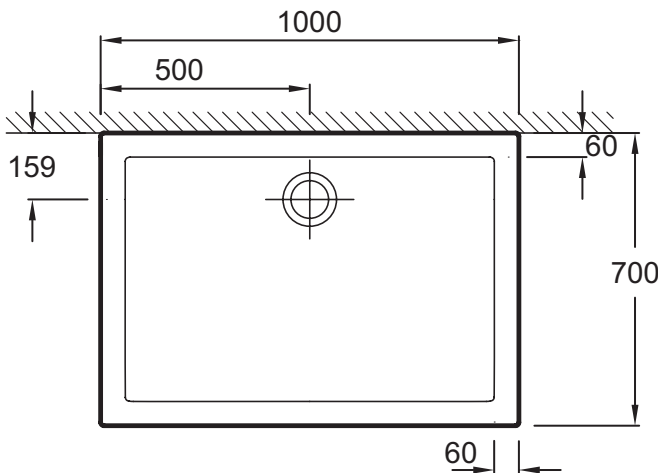

Product Specification: Extra-slim shower tray, ENN90. Collection: KYREO. DIMENSIONS: 100 x 70 x 4 cm. WEIGHT: 27.4 kg. MATERIAL: Ceramic. INSTALLATION TYPE: Floorstanding or inset. NORMS AND REGULATION: NF. SHAPE: Rectangular. WASTE DIAMETER: 9. SURFACE PATTERN: Smooth. ADHERENCE: PN6. WASTE SUPPLIED: No. 10-year warranty.

\*Due to possible variations in computer and printer calibrations, technical factors and certain finish characteristics, the colors you see may not accurately portray the actual colors and are provided as a guide only.