

Seiton 4-2 L

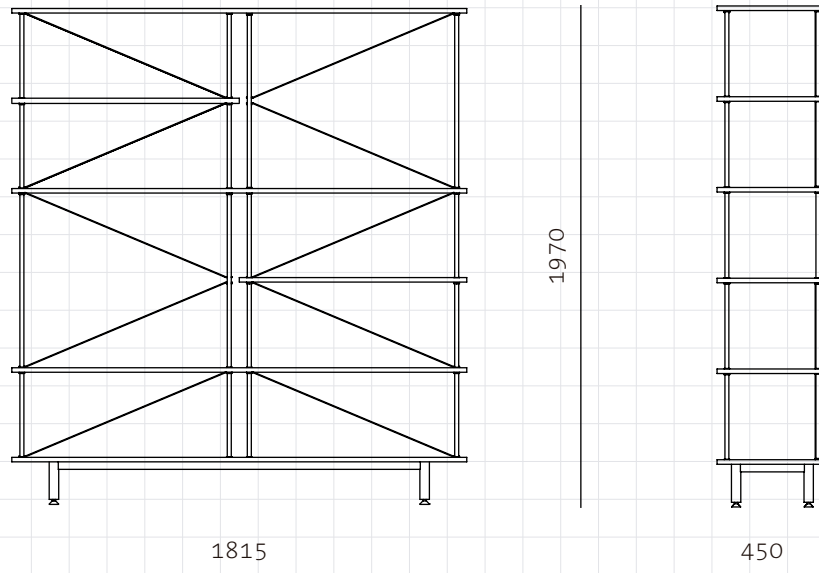

**CODE**  
**DIMENSIONS**

SE-SF142-L  
W1815 x D450 x H1970mm

**NET WEIGHT**  
**ENVIRONMENT**  
**MATERIALS**

67.0 kg  
Indoor  
Powder coated steel frame, veneer laminate shelves

\*Please refer to website or contact your local representative for complete material swatches.

**SHIPPING**

<b>Package</b>	KD		
<b>Package Qty</b>	1 pcs/box		
<b>Packaging</b>	<b>Measurement (mm)</b>	<b>Volume (cbm)</b>	<b>Gross Weight (kg)</b>
<b>FCL</b>	W1915 x D550 x H250	0.26	71.33
<b>LCL/AIR</b>	W1955 x D590 x H340	0.39	84.73