

Seiton 5-1 R

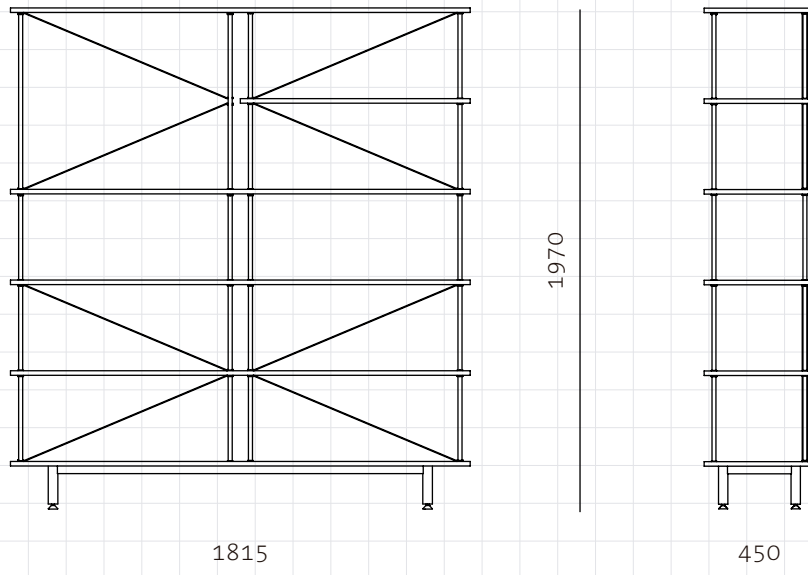

CODE

SE-SF151-R

DIMENSIONS

W1815 x D450 x H1970mm

NET WEIGHT

70.0 kg

ENVIRONMENT

Indoor

MATERIALS

Powder coated steel frame, veneer laminated top, brass plated stainless steel/powder coated steel legs

*Please refer to website or contact your local representative for complete material swatches.

SHIPPING

Package	KD		
Package Qty	1 pcs/box		
Packaging	Measurement (mm)	Volume (cbm)	Gross Weight (kg)
FCL	W1915 x D550 x H250	0.26	74.33
LCL/AIR	W1955 x D590 x H340	0.39	87.73