

QT Coffee Table C450

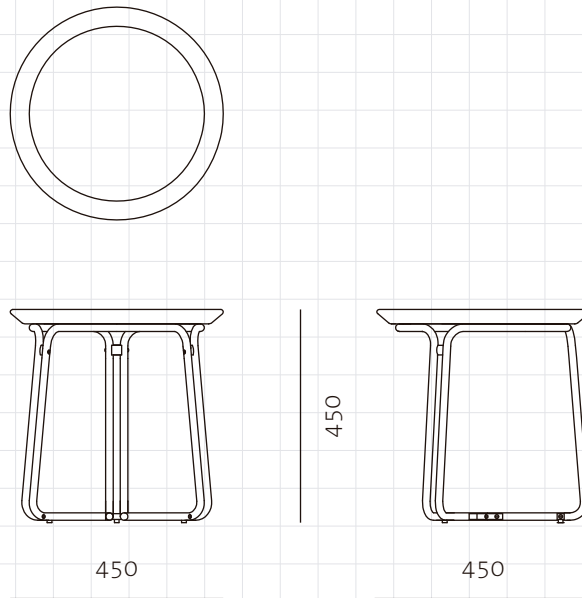

**CODE**

QT-T210-450

**DIMENSIONS**

W450 x D450 x H450mm

**NET WEIGHT**

4.0 kg

**ENVIRONMENT**

Indoor

**MATERIALS**

Veneer laminate top, Powder coated steel base, Brass plated stainless steel connectors

\*Please refer to website or contact your local representative for complete material swatches.

**SHIPPING**

<b>Package</b>	Assembled		
<b>Package Qty</b>	1 pcs/box		
<b>Packaging</b>	<b>Measurement (mm)</b>	<b>Volume (cbm)</b>	<b>Gross Weight (kg)</b>
<b>FCL</b>	W515 x D515 x H535	0.14	7.0
<b>LCL/AIR</b>	W535 x D535 x H630	0.18	11.0