

Seiton 3

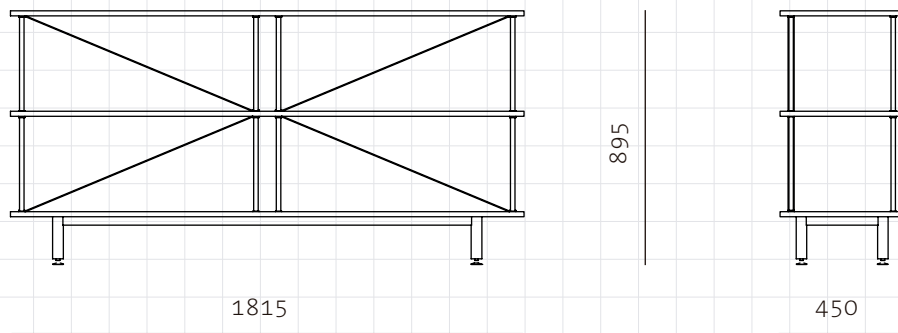

**CODE**

SE-SF130

**DIMENSIONS**

W1815 x D450 x H895mm

**NET WEIGHT**

39.0 kg

**ENVIRONMENT**

Indoor

**MATERIALS**

Powder coated steel frame, veneer laminated top, brass plated stainless steel/powder coated steel legs

\*Please refer to website or contact your local representative for complete material swatches.

**SHIPPING**

<b>Package</b>	KD		
<b>Package Qty</b>	1 pcs/box		
<b>Packaging</b>	<b>Measurement (mm)</b>	<b>Volume (cbm)</b>	<b>Gross Weight (kg)</b>
<b>FCL</b>	W1915 x D550 x H180	0.19	42.82
<b>LCL/AIR</b>	W1955 x D590 x H270	0.31	56.23