

E98633



Collection: STRAYT

Finish*:



CP - Chrome

Features

- DIMENSIONS: 16.60 x 13.50 cm
- MATERIAL: Metal
- NORMS AND REGULATION: ACS (Certificate of Sanitary Compliance): 10 ACC LY 004
- CONNECTIONS: Connect to two outlets (example: showerhead, handshower, bath spout)

Consumer benefits

- SIMPLE FUNCTIONALITY: Automatic diverter with locking option
- EVACUATION SYSTEM: Prevents condensation inside the Modulo box
- EASY GRIP: Strayt ergonomic handle

- WEIGHT: 2.8 kg
- INSTALLATION TYPE: Built-in
- COMPONENTS: Build-in body, trim and handle

Installation benefits

- FAST INSTALLATION: Fixing screws pre-mounted to cartridge box
- EASY INSTALLATION: Thanks to guide notches
- CONVENIENT MAINTENANCE: Easy access to build-in body (thermostatic cartridge, non-return valves, etc.)

Required products

- 98699D: Universal recessed box

Technical drawing

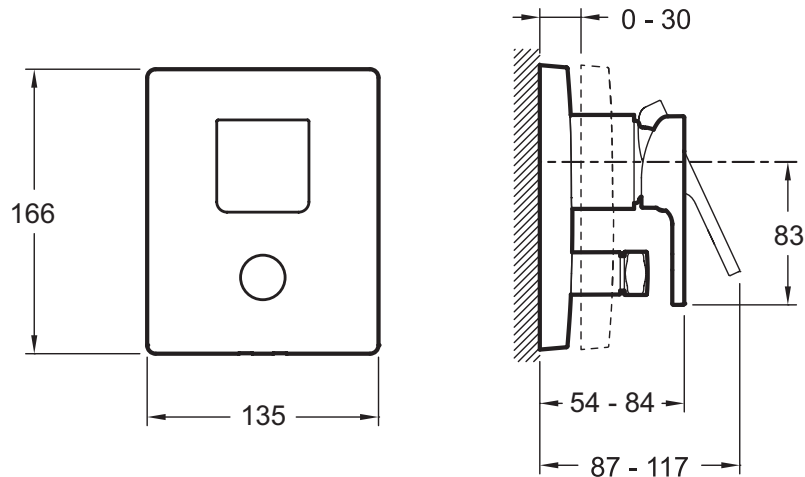

Product Specification: Two-way shower mixer, Strayt trim and lever. E98633. Collection: STRAYT. DIMENSIONS: 16.60 x 13.50 cm. WEIGHT: 2.8 kg. MATERIAL: Metal. INSTALLATION TYPE: Built-in. NORMS AND REGULATION: ACS (Certificate of Sanitary Compliance): 10 ACC LY 004. COMPONENTS: Build-in body, trim and handle. CONNECTIONS: Connect to two outlets (example: showerhead, handshower, bath spout).