

E0403



Collection: EOLIA

Finish*:



00 - White

Main features:



Features

- DIMENSIONS: 66.50 x 35.50 cm
- MATERIAL: Ceramic
- NORMS AND REGULATION: NF
- RIM TYPE: Open (traditional)
- WEIGHT: 36 kg
- INSTALLATION TYPE: Floor-standing
- VOLUME OF WATER: Standard 3/6 L

Consumer benefits

- Polypropylene seat with plastic hinges
- Silent float valve
- Water-saving button 3/6 l

Installation benefits

- EASY INSTALLATION: Quick-mount system

Technical drawing

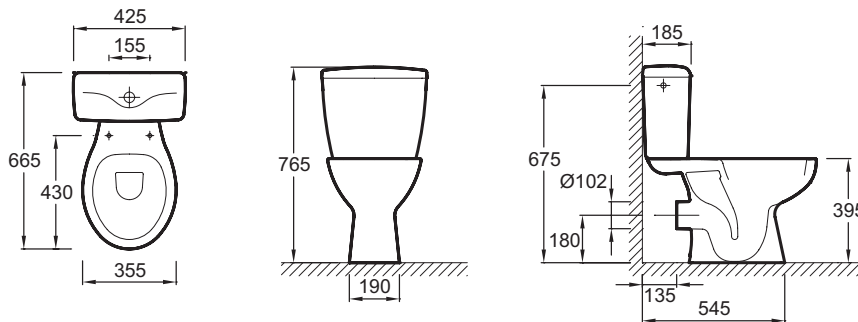

Product Specification: WC pack, P-trap. E0403. Collection: EOLIA. DIMENSIONS: 66.50 x 35.50 cm. WEIGHT: 36 kg. MATERIAL: Ceramic. INSTALLATION TYPE: Floor-standing. NORMS AND REGULATION: NF. VOLUME OF WATER: Standard 3/6 L. RIM TYPE: Open (traditional).

*Due to possible variations in computer and printer calibrations, technical factors and certain finish characteristics, the colors you see may not accurately portray the actual colors and are provided as a guide only.