

**E22FT100**



**Collection:** CONTRA

**Finish\*:**



GA - Profiles chromés

**Main features:**



**Features**

- DIMENSIONS: 200 x 100 cm
- MATERIAL: Clear glass
- GLASS THICKNESS IN MM: 6
- WALL ADJUSTMENT IN MM: 20 mm
- INSTALLATION: Close Space
- HAUTEUR : 200 cm.
- WEIGHT: 34 kg
- INSTALLATION TYPE: Fixed panel
- PANEL HEIGHT IN CM: 200
- ENCLOSURE TYPE: Fixed side panel
- SECURITE : Verre transparent de sécurité 6 mm.
- ADAPTABILITE : Permet l'installation d'une Contra pivotante en angle.

**Consumer benefits**

- DESIGN EN TRANSPARENCE : Porte sans encadrement totalement épurée.
- ACCESSIBILITE : Très large espace de douche.

**Installation benefits**

- INSTALLATION : Compensation murale de 20 mm.

**Required products**

- E22BW90: Horizontal bar
- E22BT: ff

**Technical drawing**

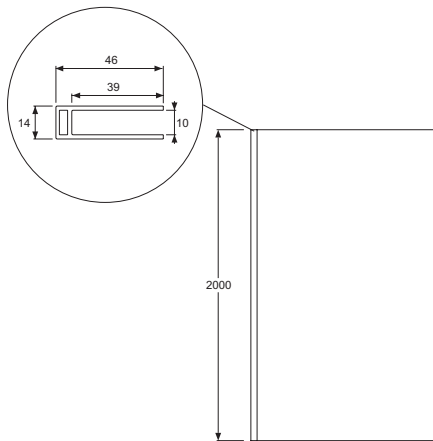

	E22FT70	E22FT80	E22W90	E22W100	E22W110	E22W120	E22W130	E22W140
Mm	700	800	900	1000	1100	1200	1300	1400
A mini/maxi	650 / 685	750 / 785	870 / 890	970 / 990	1070 / 1090	1170 / 1190	1270 / 1290	1370 / 1390

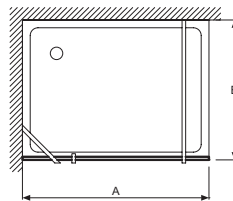

Product Specification: Fixed side pane for pivot door 100 cm. E22FT100. Collection: CONTRA. DIMENSIONS: 200 x 100 cm. WEIGHT: 34 kg. MATERIAL: Clear glass. INSTALLATION TYPE: Fixed panel. GLASS THICKNESS IN MM: 6. PANEL HEIGHT IN CM: 200. WALL ADJUSTMENT IN MM: 20 mm. ENCLOSURE TYPE: Fixed side panel. INSTALLATION: Close Space. SECURITE : Verre transparent de sécurité 6 mm.. HAUTEUR : 200 cm.. ADAPTABILITE : Permet l'installation d'une Contra pivotante en angle..

\*Due to possible variations in computer and printer calibrations, technical factors and certain finish characteristics, the colors you see may not accurately portray the actual colors and are provided as a guide only.