

E75415



Collection: MODULO

Finish*:



CP - Chrome

Features

- **DIMENSIONS:** 18 x 14 cm
- **MATERIAL:** Metal
- **WEIGHT:** 2 kg
- **INSTALLATION TYPE:** Wall-mount

Consumer benefits

- **EXCELLENT GRIP:** Ergonomic handle
- **FUNCTIONALITY:** 3-way diverter with 3 intermediate positions so 2 outlets operate simultaneously
- **FINISH:** Chrome - 10-year warranty
- **MECHANISM-DIVERTER:** 5-year warranty

Installation benefits

- **QUICK INSTALLATION:** Pre-assembled fixing screws
- **COMPOSITION:** Build-in body, trim and handle

Required products

- 98699D: Universal recessed box

Technical drawing

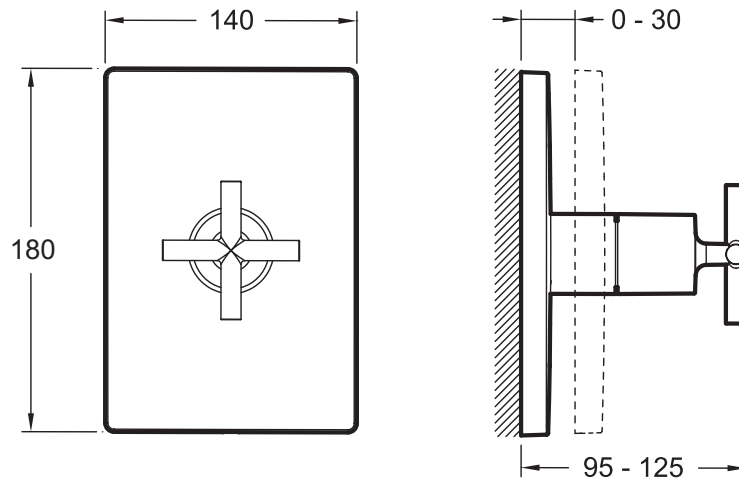

Product Specification: 3 + 3-way built-in diverter - Classic trim. E75415. Collection: MODULO. DIMENSIONS: 18 x 14 cm. WEIGHT: 2 kg. MATERIAL: Metal. INSTALLATION TYPE: Wall-mount.

**Due to possible variations in computer and printer calibrations, technical factors and certain finish characteristics, the colors you see may not accurately portray the actual colors and are provided as a guide only.*