

1) Praticare due fori da \varnothing 8 mm alla distanza di 846 mm.

1) Make two holes of diameter 8 mm at a distance of 846 mm.

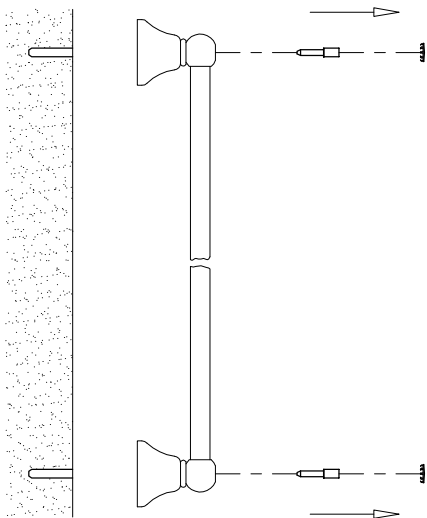

2) Rimuovere le placchette e le spine.

2) Remove the plates and the plugs.

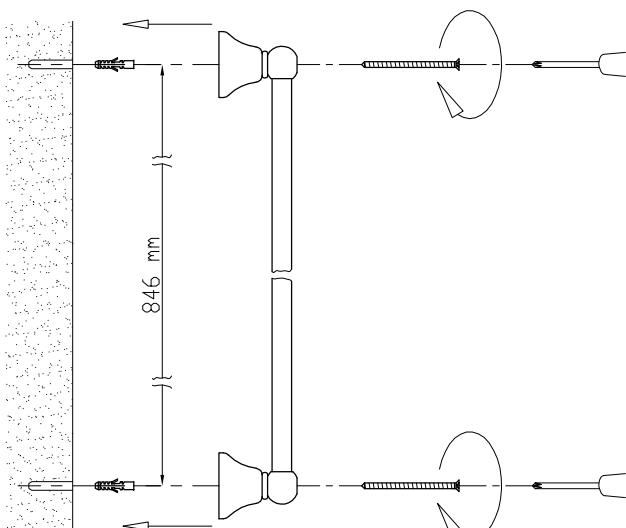

3) Inserire i tasselli e fissare con le viti.

3) Insert the two dowels and fix with the screws.

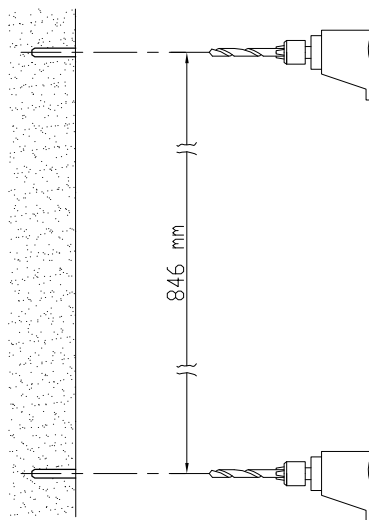

1) Praticare due fori da \varnothing 8 mm alla distanza di 846 mm.

1) Make two holes of diameter 8 mm at a distance of 846 mm.

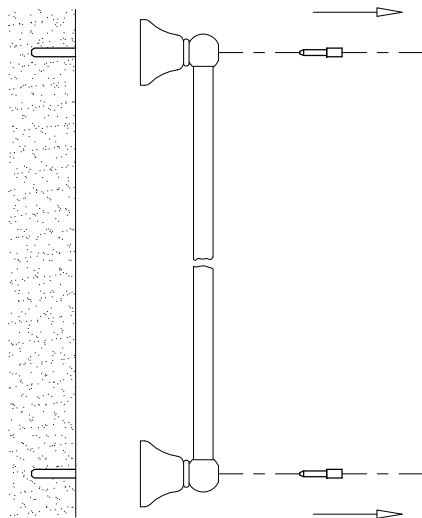

2) Rimuovere le placchette e le spine.

2) Remove the plates and the plugs.

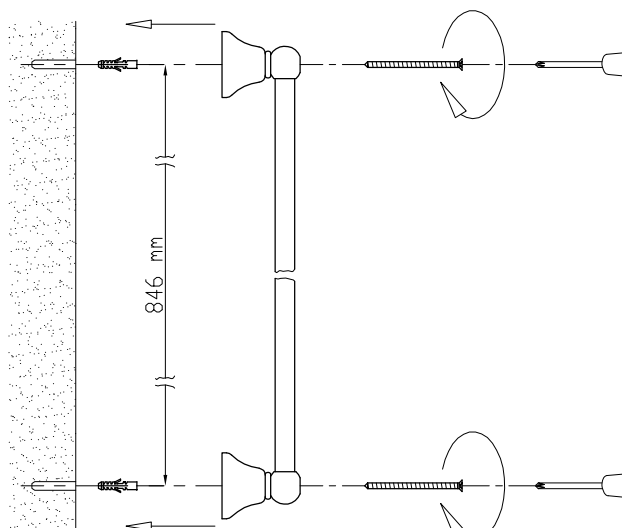

3) Inserire i tasselli e fissare con le viti.

3) Insert the two dowels and fix with the screws.

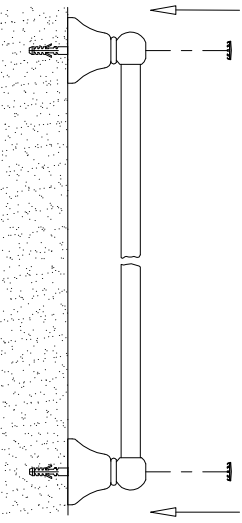

4) Applicare le placchette a pressione.

4) Put the plates with pressure.

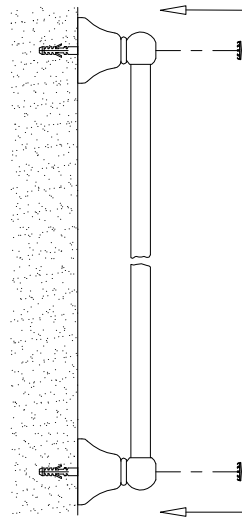

4) Applicare le placchette a pressione.

4) Put the plates with pressure.