

Lunar Lounge Chair Large

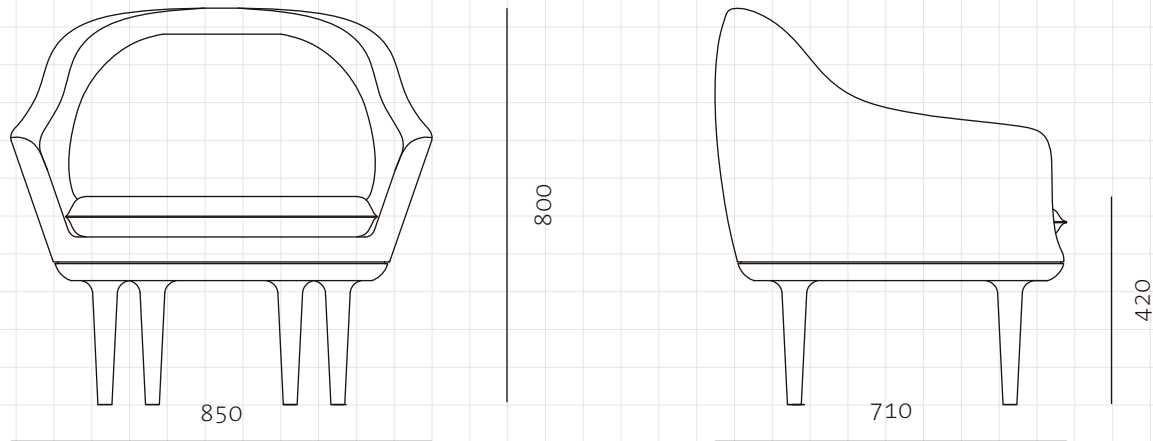

CODE
DIMENSIONS

LN-S111-L
W850 x D710 x H800mm
Seating height: 420mm

NET WEIGHT
ENVIRONMENT
MATERIALS

23.5 kg
Indoor
Solid wood legs, upholstered moulded foam frame, upholstered cushion
*Please refer to website or contact your local representative for complete material swatches.

SHIPPING

Package	Assembled		
Package Qty	1 pcs/box		
Packaging	Measurement (mm)	Volume (cbm)	Gross Weight (kg)
FCL	W900 x D800 x H820	0.59	30.47
LCL/AIR	W920 x D820 x H915	0.69	39.23