

Ming Aluminum Café Table

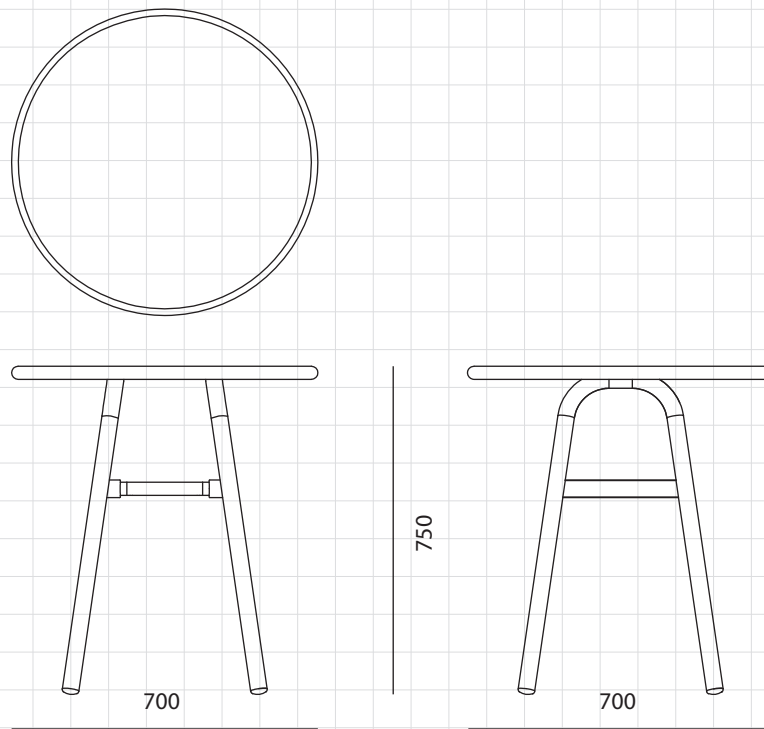

CODE

MI-T310

DIMENSIONS

W700 x D700 x H750mm

NET WEIGHT

9.0 kg

ENVIRONMENT

Outdoor

MATERIALS

Aluminum, Available in black/grey/white

*Please refer to website or contact your local representative for complete material swatches.

SHIPPING

Package	Knock Down		
Package Qty	1 pcs/box		
Packaging	Measurement (mm)	Volume (cbm)	Gross Weight (kg)
FCL	W805 x D750 x H155	0.09	12.0
LCL/AIR	W825 x D770 x H250	0.16	19.0