

MICRO MENHIR bollard

Design by
LUNDBERGDESIGN

IT Istruzioni di montaggio

EN Assembly instructions

DE Instructions de montage

FR Montageanleitung

ES Instrucciones de montaje



More details at:
platek.eu/MENHIR



Platek®

SAFETY AND WARNINGS

- I Sicurezza e avvertenze per l'installazione:
- L'installazione e la messa in funzione devono essere eseguite esclusivamente da personale qualificato.
 - Eseguire lavori agli apparecchi esclusivamente a tensione nulla.
 - Effettuare il collegamento alla rete seguendo le normative d'installazione vigenti.
 - Non rimuovere il cavo di alimentazione.
 - La connessione alla rete deve essere con morsetti a vite certificati, 250V, 3 x 2,5 mm², 3 x 1,5 mm², 2 x 2,5 mm² o 2x1,5mm², in scatola di derivazione con gradi di protezione ≥ IP 65.
 - Ad ogni cambio lampada sostituire la guarnizione.
 - Usare solo lampade UV-STOP.
 - Effettuare la sostituzione della lampada solo quando l'apparecchio è raffreddato e privo di tensione.
 - Utilizzare l'apparecchio solo con vetro completo.



- GB Safety and warnings for installation:
- Installation and start-up must be carried out by qualified personnel only.
 - Carry out operations on device only with device disconnected from power supply.
 - Connect to mains following the installation regulations in force.
 - Do not remove power cable.
 - Connection to the mains must be performed with certified screw connectors, 250V, 3 x 2.5 mm², 3 x 1.5 mm², 2 x 2.5 mm² or 2 x 1.5 mm², in junction box with protection level ≥ IP 65.
 - Replace gasket at every relamping.
 - Use only UV-STOP lamps.
 - Replace lamp only when the device has cooled down and is not powered.
 - Use the device only with a complete glass.



- F Sécurité et avertissements pour l'installation:
- L'installation et la mise en service doivent être effectuées uniquement par un personnel qualifié.
 - Travailler toujours sur les appareils hors tension.
 - Le câblage au réseau doit être réalisé dans le respect des réglementations en vigueur en matière d'installation.
 - Ne pas enlever le câble d'alimentation.
 - Le câble au réseau doit être réalisé par des bornes à vis certifiées, 250V, 3 x 2,5 mm², 3 x 1,5 mm², 2 x 2,5 mm² ou 2 x 1,5 mm², dans une boîte de dérivation à degré de protection ≥ IP 65.
 - Remplacer le joint à chaque changement de lampe.
 - Utiliser uniquement des lampes UV-STOP.
 - Avant de remplacer la lampe, mettre l'appareil hors tension et attendre qu'il soit refroidi.
 - N'utiliser l'appareil qu'avec le verre complet.



- D Sicherheits- und Installationshinweise:
- Die Montage und der elektrische Anschluss dürfen nur von entsprechend qualifizierten Fachkräften durchgeführt werden.
 - Arbeiten an der Leuchte dürfen nur im spannungsfreien Zustand durchgeführt werden.
 - Netzanschluss entsprechend den Anforderungen der Errichtungsbestimmungen durchführen.
 - Die Netzleitung darf nicht entfernt werden.
 - Es sind zertifizierte Schraubklemmen 250V, 3 x 2,5 mm², 3 x 1,5 mm² oder 2 x 1,5 mm² und Abschluss- bzw. Abzweigdosen der Schutzart IP 68 zu verwenden.
 - Bei jedem Leuchtmittelwechsel ist auch die Dichtung auszutauschen.
 - Nur Lampen UV-STOP benutzen.
 - Leuchtmittelwechsel nur im abgekühlten und spannungs-freien Zustand der Leuchte durchführen.
 - Leuchte nur mit unbeschädigter Scheibe betreiben.



- E Seguridad y advertencias para la instalación:
- La instalación y la puesta en servicio deben realizarse exclusivamente por parte de personal cualificado.
 - Bajo ningún concepto se podrá trabajar sobre aparatos que no estén sin tensión.
 - La conexión a la red debe realizarse de acuerdo con las normas de instalación vigentes.
 - No quitar el cable de alimentación.
 - La conexión a la red debe hacer con bornes de tornillo certificados, 250V, 3 x 2,5 mm², 3 x 1,5 mm², 2 x 2,5 mm² o 2 x 1,5 mm², en caja de derivación con grado de protección ≥ IP 65.
 - Cada vez que se cambia la lámpara, reemplazar la junta de cierre.
 - Utilizar únicamente lámparas UV-STOP.
 - Antes de cambiar la lámpara, dejar el aparato sin tensión y esperar que se enfríe.
 - Utilizar el aparato sólo con vidrio completo.



LED MODUL

- I ATTENZIONE: Accertarsi che le linee siano protette da sovra tensioni.
- GB CAUTION: Make sure that the lines are protected from over-voltage.
- F ATTENTION: Assurez-vous que les lignes sont protégées contre les surtensions.
- D ACHTUNG: Es ist sicherzustellen, dass die Netzzuleitungen gegen Überspannungen geschützt sind.
- E PRECAUCIÓN: Asegúrese de que las líneas estén protegidos contra la sobretensión.
- P CUIDADO: Certifique-se de que as linhas estão protegidos contra o excesso de tensão.



- I Non fissare direttamente la luce. Modulo LED Classe 1.
In caso di guasto del modulo LED rivolgersi a Platek.
- GB Do not look into the beam. LED-Module Class 1.
In case of malfunctions with the LED module, please contact Platek.
- F Module de la LED Classe 1.
En case de défaillance du module de la DEL, veuillez vous adresser à Platek.
- D Nicht in den Strahl blicken. LED-Modul Klasse 1.
Bei Störungen des LED-Moduls wenden Sie sich bitte an Platek.
- E No fije la vista en el rayo. Módulo LED Clase 1.
En caso de avería del módulo LED, póngase en contacto con Platek.
- P Não olhe diretamente para a luz. Classe 1 módulo de LED.
Em caso de falha do módulo de LED, entre em contato Platek.



- I Si sconsiglia l'accensione dell'apparecchio durante le ore diurne con forte irraggiamento solare.
- GB We do not recommend switching on the fitting during the day with strong solar radiation.
- F Nous déconseillons d'allumer l'appareil pendant la journée avec un fort rayonnement solaire.
- D Es wird empfohlen, LED-Leuchten tagsüber bei direkter Sonneneinstrahlung auf keinen Fall in Betrieb zu nehmen.
- E No se recomienda encender el aparato durante las horas diurnas con fuerte radiación solar.

SAFETY AND WARNINGS

- I L'apparecchio non deve essere messo a contatto con sostanze chimiche aggressive tipo fertilizzanti ecc.
- GB Do not put device in contact with aggressive chemical substances, such as fertilizers, etc.
- F Interdiction de mettre l'appareil en contact avec des substances chimiques agressives telles que des fertilisants, etc.
- D Die Leuchte darf nicht mit aggressiven Substanzen, Chemikalien, Reinigungsmittel und/ oder Düngemitteln in Kontakt kommen.
- E El aparato no debe ponerse en contacto con sustancias químicas agresivas tales como fertilizantes, etc.



TECHNICAL DATA

MICRO MENHIR

IP65



Gruppo rischio (EN 62471:2008) / Risk group (EN 62471:2008)

1

	IT	Classe	Alimentazione	Peso	
	EN	Class	Power supply	Weight	
	DE	Schutzklasse	Versorgung	Gewicht	
	FR	Classe	Alimentation	Poids	
	ES	Clase	Alimentación	Peso	
10W			220-240V 50/60 Hz	1,60 Kg	MICRO MEHIR 150
15W			220-240V 50/60 Hz	3,40 Kg	MICRO MENHIR 500
15W			220-240V 50/60 Hz	5,00 Kg	MICRO MENHIR 800

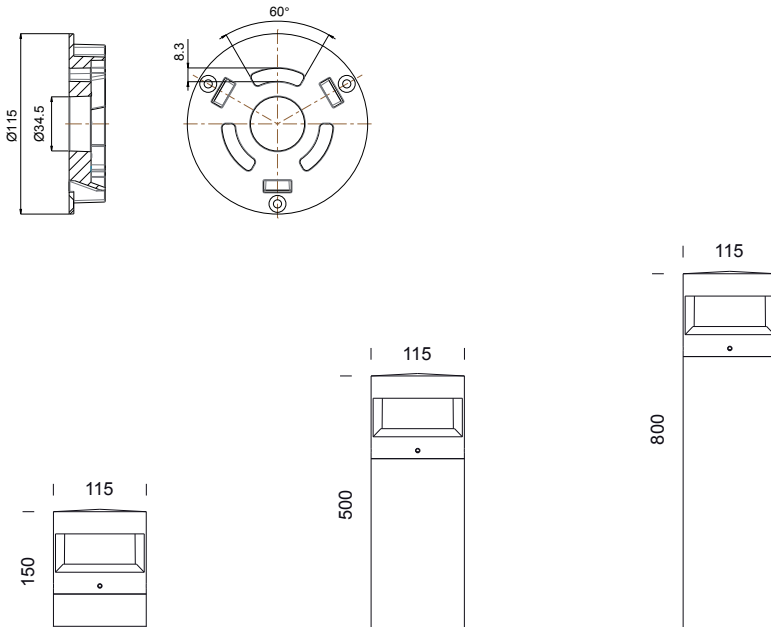

INSTALLATION

8950030

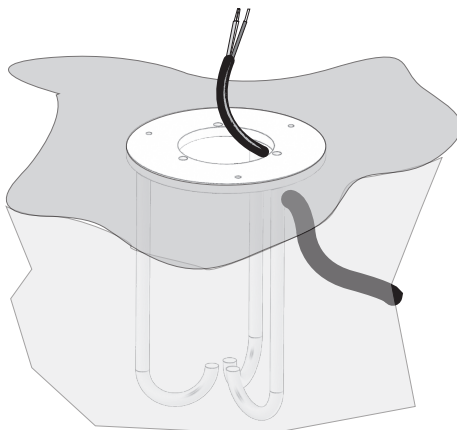
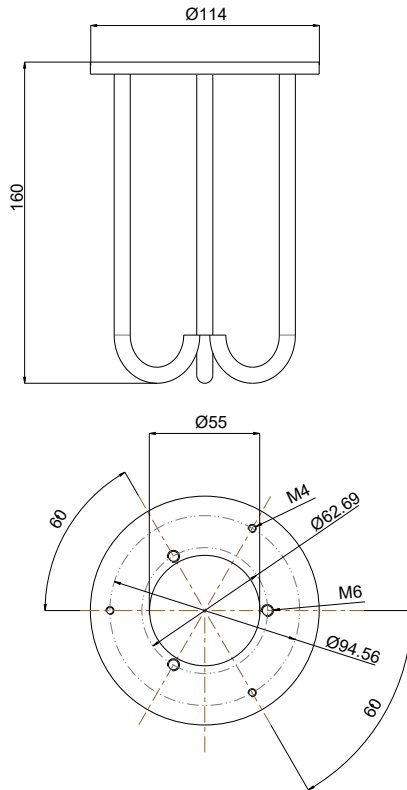

INSTALLATION

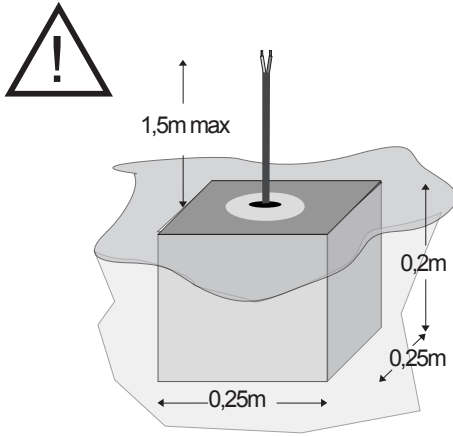

OK!

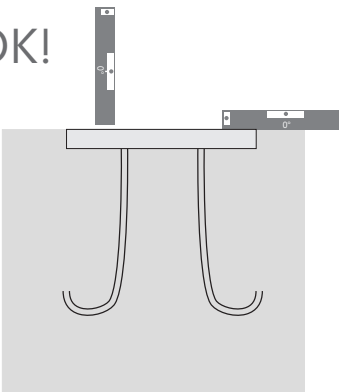

OK!

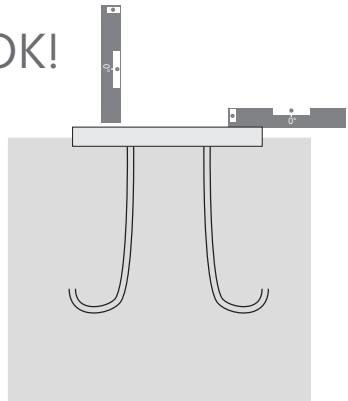

NO!

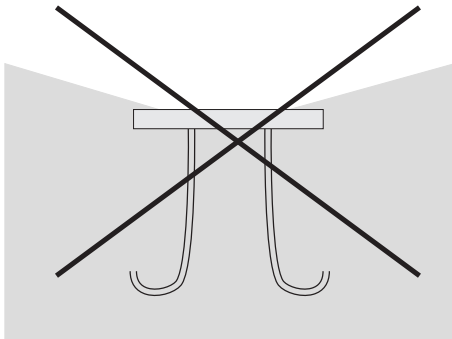

NO!

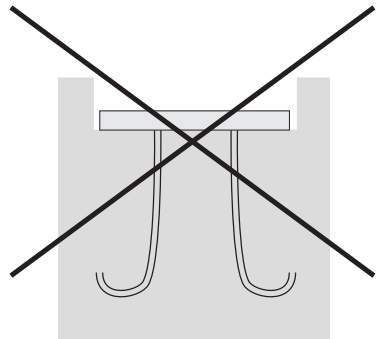

MICRO MENHIR 150

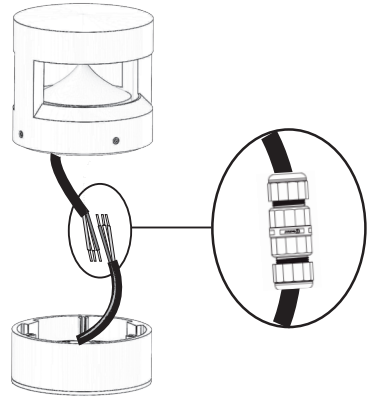
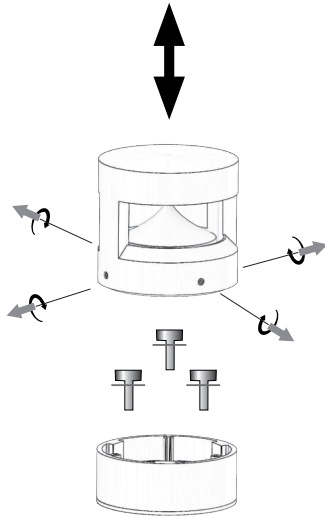

- IT** Connettore fornito
- EN** Connector supplied
- DE** Kabelverbinder inklusive
- FR** Connecteur fourni
- ES** Conector suministrado

- Ø cavi 7-12mm <HAR>
- Ø cables 7-12mm <HAR>
- Ø câbles 7-12mm <HAR>
- Ø du holstheraus 7-12mm <HAR>
- Ø cables 7-12mm <HAR>
- Ø cabos 7-12mm <HAR>

YES



NO

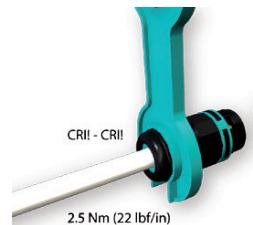
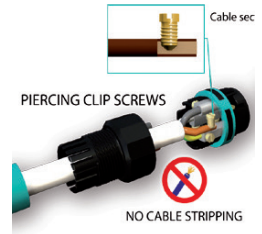

INSTALLATION

MICRO MENHIR 500-800

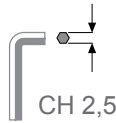

- Ø cavi 7-12mm <HAR>
- Ø cables 7-12mm <HAR>
- Ø câbles 7-12mm <HAR>
- Ø du holstheraus 7-12mm <HAR>
- Ø cables 7-12mm <HAR>
- Ø cabos 7-12mm <HAR>

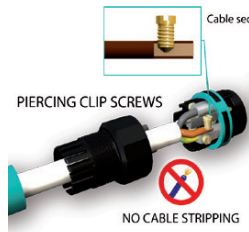
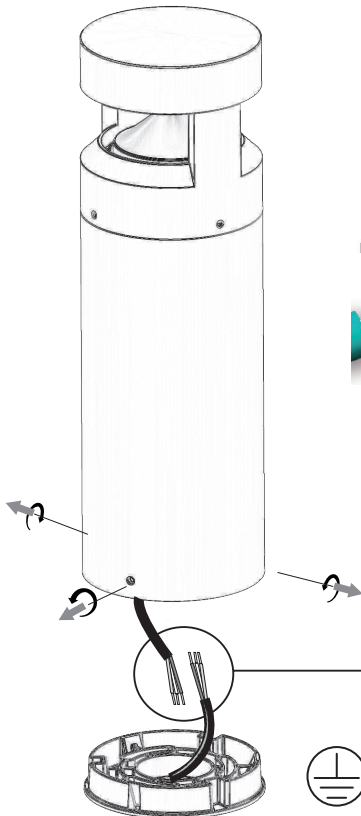

- IT Connettore fornito
- EN Connector supplied
- DE Kabelverbinder inklusive
- FR Connecteur fourni
- ES Conector suministrado

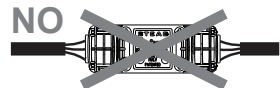

INSTALLATION

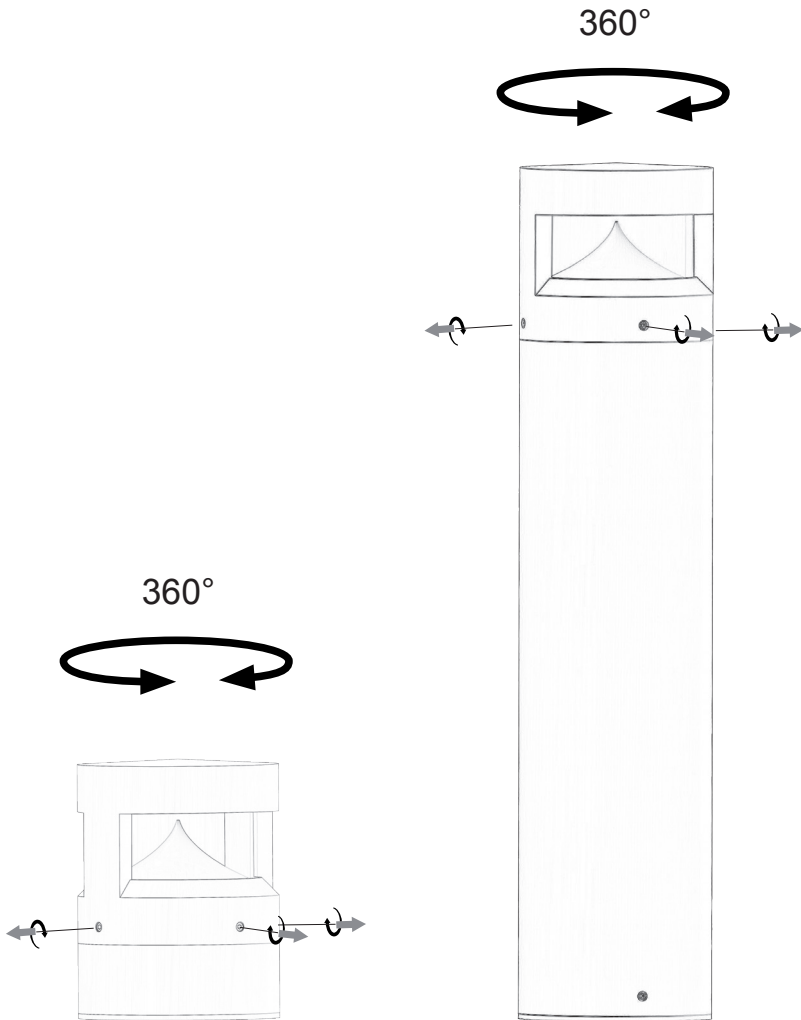

INSTALLATION

IT **COME POSSIAMO ESSERE D'AIUTO?**

Ottieni supporto tramite telefono o E-mail, contattandoci al +39 030 68 18 201 o scrivendo all'indirizzo E-mail supporto@platek.eu

EN **HOW CAN WE HELP YOU?**

Get support by phone or e-mail, call us on +39 030 68 18 201 or send us an email supporto@platek.eu

DE **WIE KÖNNEN WIR IHNEN HELFEN?**

Sie können unseren Kundendienst per Telefon oder E-Mail erreichen. Kontaktieren Sie uns unter der Telefonnummer +39 030 68 18 201 oder schreiben Sie an folgende E-Mail-Adresse supporto@platek.eu

FR **COMMENT POUVONS-NOUS VOUS AIDER?**

Vous pouvez obtenir de l'aide par téléphone ou bien par email, en nous contactant +39 030 68 18 201 ou bien en nous écrivant à l'adresse email supporto@platek.eu

ES **¿PODEMOS AYUDARTE?**

Solicita soporte a través de nuestro teléfono o email, contactándonos al +39 030 68 18 201 o escribiendo a nuestra dirección de correo electrónico supporto@platek.eu

PLATEK SRL
T + 39 030 6818201
E-MAIL INFO@PLATEK.EU
WWW.PLATEK.EU

REGISTERED OFFICE:
VIA PADERNO 19
25050 RODENGO SAIANO
(BS) ITALY

HEAD OFFICE:
VIA MARROCCO 4
25050 RODENGO SAIANO
(BS) ITALY



- IT Conservare le istruzioni.
- EN Retain the instructions.
- DE Bewahren Sie die Anleitung.
- FR Conservez ces instructions.
- ES Conserve las instrucciones.