



Name: TAU 1 LUZ

Design: Joana Bover / 2003

Typology: Pendant lamp

Environment: Indoor

Technical description:

Pendant lamp with brass structure coated in satin nickel, nickel with dark leather trim, or nickel with light, chestnut leather trim, releasing diffused light through a rectangular lamp shade available in linen, classic cotton, white or cream translucent, hand wrapped polyester blend ribbon. Lower polycarbonate diffuser included with fixture.

Lamps description

⏏ Earthing: compulsory

💡 3 x 42 W Classic P ECO E-27

💡 3 x 11 W E-27

Voltage: 230V-50Hz

📦 1 Box 35 x 45 x 165 cm

Vol.: 0,2599 m³

Weight: 4 kg

Certifications:  

Ref Finishings

4323905 Satin nickel

4323960 Nickel dark leather

4323961 Nickel caramel leather

Rectangular lampshade 100 x 30 x 80,5 cm
With lower diffuser

P-482C Linen

P-483C Cotton

P-683 White translucent ribbon

P-684 Cream translucent ribbon

Customizable



Measures

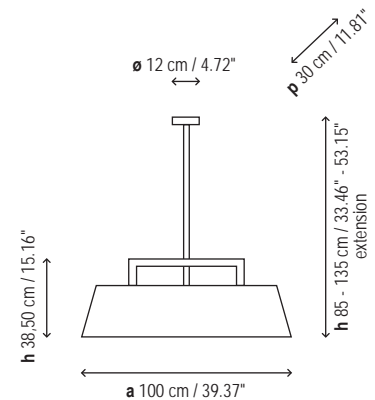

Project information

Project name: _____

Approved by: _____

Fixture type: _____

Date: _____

Location: _____

Prepared by: _____

Comments: _____

Prepared for: _____

Photometrics