

KIRI SATINJET FLUSH MOUNTED DRENCHER INSTALLATION GUIDE

TECHNICAL SPECIFICATIONS

Operating Pressure:

Min 35 kPa, Max 500 kPa.

Recommended installation of a pressure limiting valve if supply exceeds 500 kPa.

Operating Temperature:

Max 70°C

NB: New Zealand building code clause G12 - water supplies specifies all outlets used primarily for personal hygiene shall deliver water at a safe temperature.

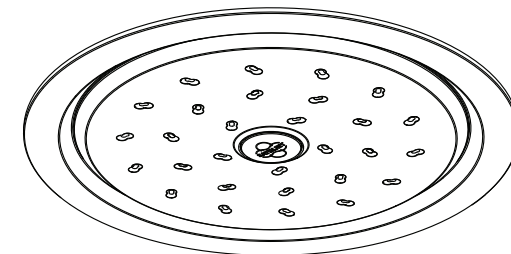

Methven warrants this product against manufacturing defects and that it is suitable for use under the operating conditions specified in this instruction sheet.

For your warranty please refer to www.methven.com or call Customer Service: 0800 804 222



1.

1/2" male threaded elbow

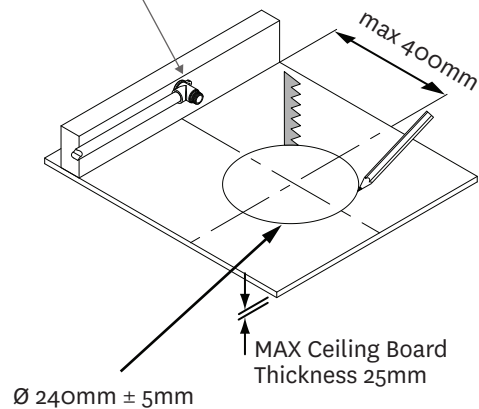

Install a 1/2" male threaded elbow connection less than 400mm from the centre of the showerhead installation position.

Using the supplied template mark a 240mm diameter hole in the desired installation position. Carefully cut the hole in the plaster board ceiling following the marked line with an appropriate plaster board saw.

NOTE: A minimum ceiling cavity of 90mm is required for the installation and bracing of the hole maybe required in some circumstances.

2.

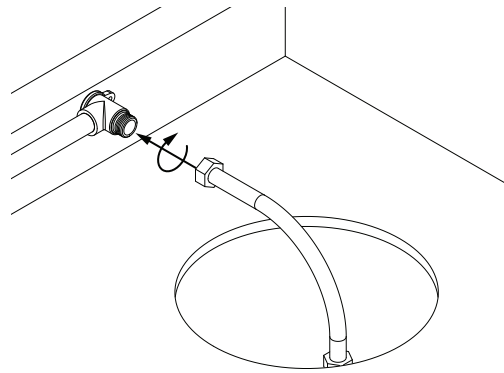

Connect the straight end of supplied braided hose to the elbow in the ceiling cavity.

NOTE: Use appropriate plumbing techniques to ensure a reliable seal

3.

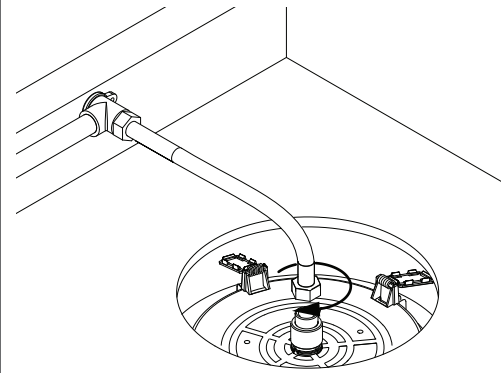

Offer up the showerhead and connect the elbow end of the braided hose to the 1/2" adapter fitting on the back of the showerhead.

NOTE: Turn the water supply on and check thoroughly for any leaks.

4.

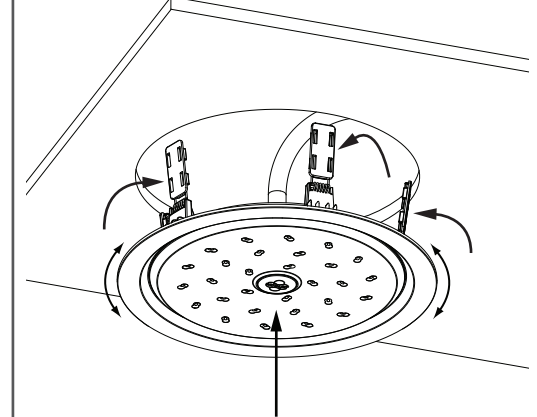

Rotate the showerhead to the desired position ensuring the hose remains untwisted. Fold a securing spring in-board and push the showerhead up to the installation hole. Progressively fold the remaining springs in-board until the showerhead pulls tight to the ceiling.

5.

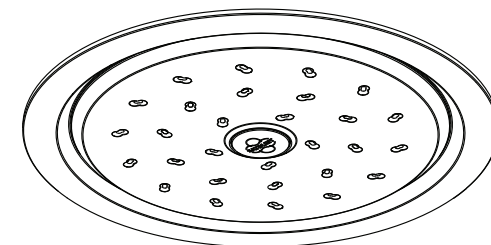

CLEANING

Water contains lime which remains on the surface after the water has evaporated. These lime deposits can be prevented from forming by wiping immediately after use.

To clean the chrome-plated surfaces use a soft cloth, soap and warm water. Never use cleaning agents that contain a corrosive acid or a scouring additive.



Do not use any sharp objects to clean nozzles

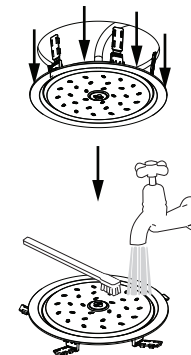

Clean filter washer periodically.

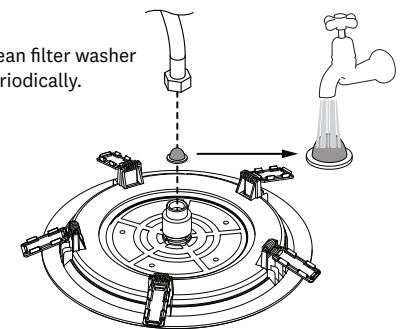

NOTE: Removal of the flow restrictor in the ball joint may be necessary to optimise flow performance in low or unequal pressure systems only.