

jot.jot

MODERN FURNITURE COLLECTION



2019

Let emotions think.

About

Tables

LOOP side table	8
Dedu coffee table	12
Euclid dining table	16
Black Mamba dining table	20

Lighting

Circle of Light pendant lamp	26
-------------------------------------	----

Seaters

Shadow chair & barstool	34
YAY stool & barstool	38
Brick family	44
BaBa family	48
Basset family	54
Roulade sofa	58

Accessories

Mudu mirror	64
Frame coat rack	68
Let's play rug	72
Piano album cover rug	74
Harlequin rug	76
Six seasons rug	78
Psychoanalysis rug	80

Storage

Cross shelving system	84
Oba storage units	88

jot.jot gathers talented and visionary individuals, generates challenging conceptions, employs latest technologies, uses highest quality materials, offers exceptional design items and goes an extra mile for their clients.

jot.jot is a venture of professionals who founded the company with a clear desire to rally the outstanding and the ingenious - ideas and designers. And the result of this endeavor is precisely just that - circulation of quality interior items for the contemporary design solutions.

The founder and owner of jot.jot - Jurgis - is a visionary soul with a combination of entrepreneurship and artistry. With a decade of experience in the unconventional design production, Jurgis is well recognized in his respective fields. As a production professional in interior and furniture industries he has a heightened sensation of manufacturing processes, which translates into the jot.jot design items. Brand products feature quality material and perfect finish.

The co-owner of jot.jot - Laurynas - is a matter-of-fact as well as a down-to-earth person, who is extremely appreciated and valued for his objective, practical and realistic point of view. With his extensive experience in financial, economic and marketing sectors, Laurynas makes a solid and welcome contribution to the Brand's growth and prominence. He also has an eye for quality design items and natural sense of subtle beauty.

The interaction of these two contrasting, but complementing personalities brings forth the most out of two worlds.

The brand name jot.jot is derived from a word "jot". As a verb it means to write down something quickly, while as a noun it stands for an amount equal to a fraction, particle or hint. Double "jot" signifies the creativity and assurance in jotting the sketch down. It also symbolizes the ideas and values the company endorses: simplicity and exclusiveness, exactness and imagination.

This is jot.jot style and identity. What is yours?

Jot it down.

Designers

Talented, unconventionally thinking and creative individuals, who make a memorable contribution to the world's visual perspective.



Boris Berlin Design

Boris Berlin is a founder of Boris Berlin Design and a co-founder of KOMPLOTT Design & ISKOS-BERLIN Design. Boris Berlin has curated and designed several design exhibitions and participated in many of them, and he has led a number of master classes in design schools. Also, received numerous Design Awards and distinctions and is represented in several collections of Design Museums around the World.

Products:
Shadow chair & barstool



Karolis Strautniekas

A freelance illustrator, working and living in Vilnius, Lithuania. Having finished his studies at the Fine Arts Academy in Vilnius (2011) he began working in creative industries such as advertisement, animation and graphic design. In 2013 Karolis directed his focus to illustration and commenced his career as a freelance illustrator.

Product:
Piano album cover rug



Inga Liksaite

Inga Liksaite is a visual artist, working and examining a stitch. Over the years she developed individual aesthetic language, where the textiles, mostly recognizable as moderated images, rhythmically stitched, come as sewn, embroidered wall canvases. Sometimes develop into three-dimensional objects or installations, or, in collegial work with other artists get a shape of moving pictures.

Product:
Let's play rug



Mattias Stenberg

Mattias Stenberg lives and creates in Stockholm, Sweden. He was originally trained as an engineer/researcher in Sweden and in the U.S. and holds degrees in Engineering and Architecture from the Royal Institute of Technology in Stockholm. Mattias operates a mixed architecture and design practice. His projects include contemporary residential architecture, furniture, lighting and every day object design.

Product:
Frame coat rack



Gintaras Antanas Kubilius

"Creativity is something oxymoronic - intangible yet imminent. Your idea ruptures in a sketch, and matures to achieve its final contours after hundreds of drawings. Ultimate form it assumes is unanticipated, yet present since the inception."

Products:
YAY stool & barstool
Euclid dining table



BONPART

Bonpart is a Vienna-based furniture and product design studio founded by Verena Waidmann and Lukas Gstöttner in 2016. Their collaboration is a permanent dialogue, where they draw upon different backgrounds in engineering and fine art. They aim for timeless design, resulting in projects with a certain calmness of clear-lined shapes, yet always with a playful twist.

Products:
Loop side table



etc.etc.

Inesa Malafej and Arunas Sukarevicius in 2012 started their own studio, entitled "etc.etc." During the past two years, "etc.etc." has been working for several brands in Europe. Their accomplishments were already recognized by industry's prestigious "IF" and "Red Dot" awards. "In our work we hold a deep respect to the crafts, traditions, and evolution of every object. Together with this we are constantly looking for the next step in making them new, better, different, adapting it for today's environment, technology and society."

Products:
Cross shelving system



KiBiSi

KiBiSi is an ad hoc collaboration between (Ki) kilo Design, (Bi) BIG Architecture and (Si) Skibsted Ideation. KiBiSi is among Scandinavia's most influential design groups today. KiBiSi has worked across a wide range of disciplines, creating everything from furniture and household objects, to bicycles and aircraft, and signature designs for clients across the globe. Urban Mobility, Architectural Illumination and Personal Electronics are among the global niches KiBiSi have consistently explored in recent years.

Products:
Brick family
Roulade sofa



OKIiKO studio

OKiikO is a duo since 2009. Graphic designer Laura Tulaite {Oki} & architect Eivaras Rastauskas {Iko}. "We seek Simplicity with Character. We call it Weird, but still very Lovely. OKIiKO is a shape, color, composition, structure, typology. We like to combine different materials & change their value. It's always about City culture vs Nature."

Products:
Six seasons rug
Harlequin rug
Psychoanalysis rug



Juozas Songaila

Late '80s witnessed Guns N' Roses entering the stage and Juozas embarking on the road of creativity. Designer spent his rocky adolescent years attending art gymnasium and further matured as a professional in the technical school of applied arts. Education in visual arts has led to exciting encounters with sculpture and appreciation of the plasticity the latter could offer.

Product:
Black Mamba dining table



HEIMA architects

HEIMA - a group of architects operating within the fields of architecture, interior and design. They gained their knowledge whilst studying and working in various architecture schools and studios in Switzerland, Belgium, Spain, the Netherlands and Lithuania.

Products:
Mudu mirror
Dedu coffee table
Oba storage units



ISKOS - BERLIN

ISKOS - BERLIN Design is a partnership of Boris Berlin and Aleksej Iskos. The company works within the fields of industrial, furniture and graphic design. The firm was only established in late 2010, but Boris and Aleksej have been working together for decades. In 1987, Boris co-founded Komplot Design, where Aleksej was employed as an assistant for more than 11 years. This long and fruitful cooperation has allowed them to develop a shared philosophy of design.

Products:
BaBa family
Basset family



Jurgis Garmus

Began his career in interior design by establishing and developing his own company "Gforma". For a decade he specialized in unconventional design projects for residential and commercial areas, catering to clients local as well as international. His long-lasting affair with materials and craftsmanship in interior design translates into precision and clean design of his interior items where functionality meets novelty.

Product:
Circle of Light pendant lamp

LOOP side table (by *BONPART*)
Dedu coffee table (by *HEIMA architects*)
Euclid dining table (by *Gintaras Antanas Kubilius*)
Black Mamba dining table (by *Juozas Songaila*)

Tables

for meals and deals

Loop

Side table



designed by BONPART

INTERIOR
DESIGN
NYC
DESIGN
2018 AWARDS FINALIST

The side table Loop is a versatile, contemporary piece with a strong sculptural quality. It is suitable for any environment – no matter if indoors or outdoors.

Sleek, delicate and with a twist. Loop is the discrete main character of any space in an office or home.

A clear-lined shape meets an elegant curvature resulting in an object of timeless aesthetics.



Nothing is left out of the loop with Loop.

Simple, but functional accessory ties together various interior items and styles into one entirety.

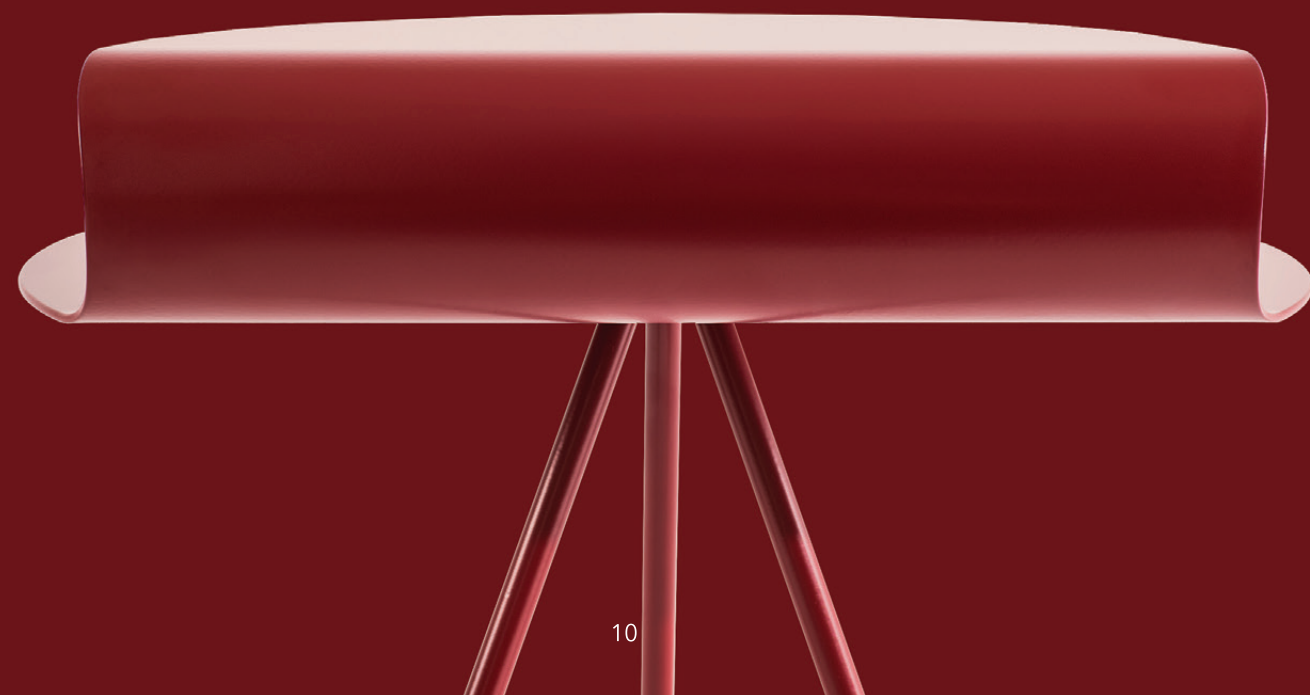

The change of location has never been so easy with a little help of convenient folding.

Technical data.

Materials:

Powder-coated steel.

Process:

Laser-cut metal sheet bended in a loop. Color powder-coating allows usage for indoor and outdoor use.

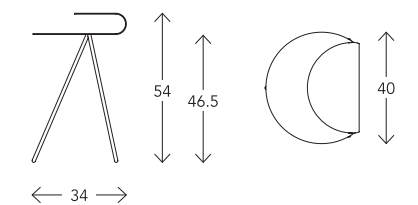

Table is available in colors:

- | | |
|----------------------|-----------------------|
| 1 - white (RAL 9010) | 2 - gray (RAL 7030) |
| 3 - black (RAL 9005) | 4 - yellow (RAL 1023) |
| 5 - red (RAL 3011) | 6 - green (RAL 6028) |
| 7 - blue (RAL 5003) | |



D e d u

Coffee table

designed by HEIMA architects



Refined, neat, slender, elegant, soft, modern, easy, fresh, beautiful and cool. DEDU coffee table is designed to hold both your glass and class.

As a representatives of Mudu family, this coffee table has loads of elegance and delicacy. No matter how one prefers them - singled out or combined - they still make an unforgettable impression through impeccable and effortlessly graceful appearance. The edge of the table was designed softly-curved to make it impossible

to resist touching it. Homogenous look of the tabletop and leg structure emphasizes the slender shape instead of material. Although the table is made of different materials, the color creates a uniform material-less look. The variation in sizes and heights allow to arrange these tables in groups.

Dedu / d38 / color: tomato cream sauce. Dedu / d60 / color: tarrytown green.



The paint hides away the differences between MDF tabletop and steel legs, thus enhancing the look of the table as a uniform entity. Only the leg tips constantly remain natural wood, regardless of the color.

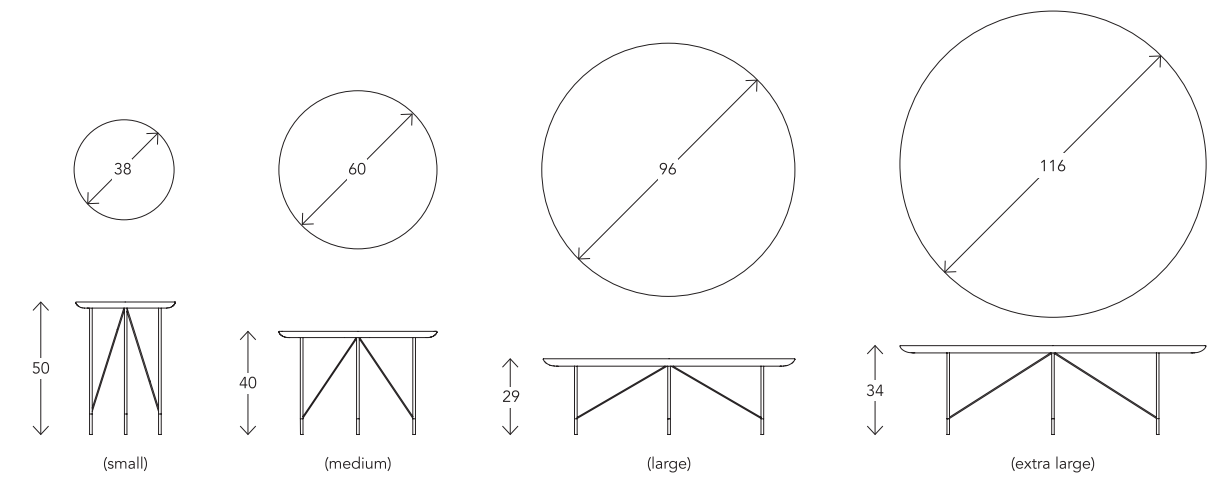
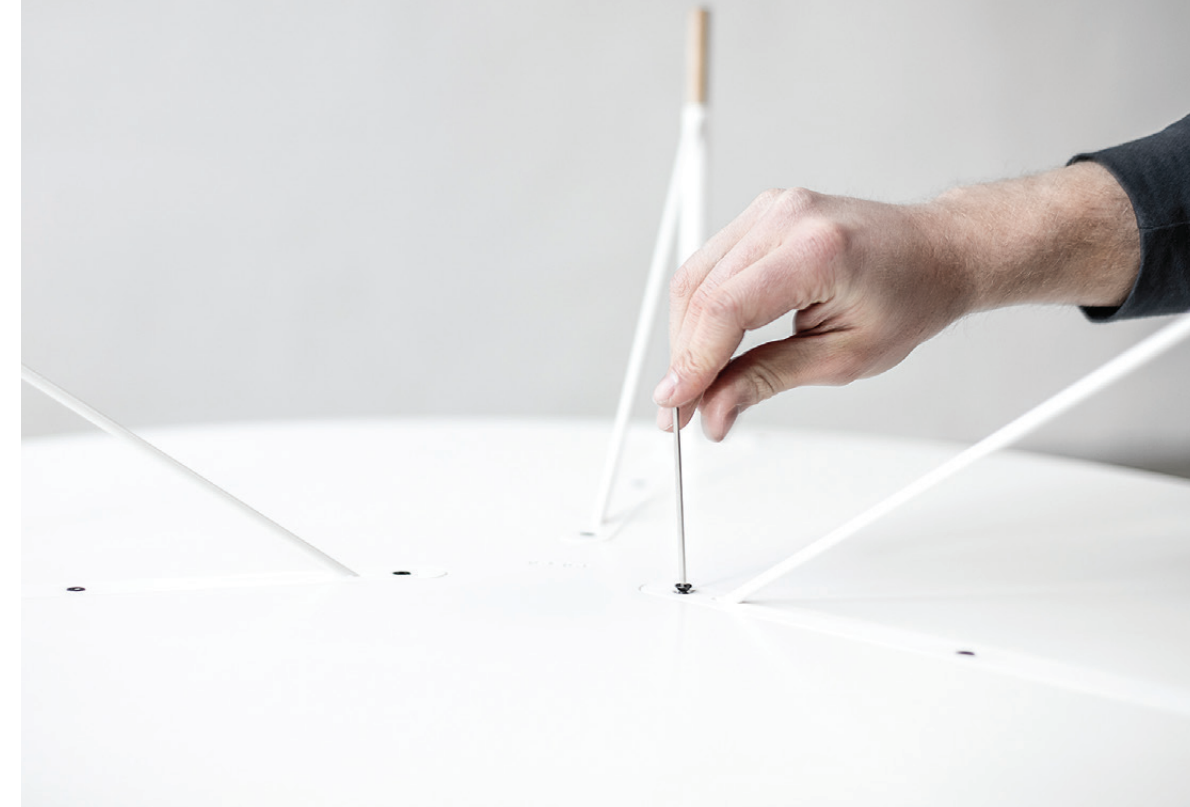

Technical data.

Materials:
MDF, painted steel legs, stained oak leg details.

Process:
The table top is made out of high-grade MDF, which was processed by using the CNC milling machine. The slender and straight-lined steel table legs are accentuated by wooden details, which strengthen the sense of harmony.

Table is available in colors:

- 1 - white
- 2 - tomato cream sauce
- 3 - rosy peach
- 4 - galapagos turquoise
- 5 - covington blue
- 6 - webster green
- 7 - tarrytown green
- 8 - ebony black



Euclid

Dining table



designed by Gintaras Antanas Kubilius



Simplicity is the highest level of complexity.

Move away from the extravagant furniture design and extend the horizons of pure solutions. Universe is constituted by three basic shapes: square, circle and triangle. So is Euclid.

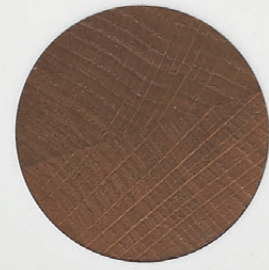

Euclid is an embodiment of minimalism, a tribute to the philosophy of geometry.

It achieves undisturbed simplicity which is the highest level of complexity. Euclid is distinguishable by its flawless integration and embodiment of three basic geometric shapes granting a tribute to the philosophy of geometry. It is also a reincarnation of minimalist design: schematic, impersonal and repetitive of elementary structures.

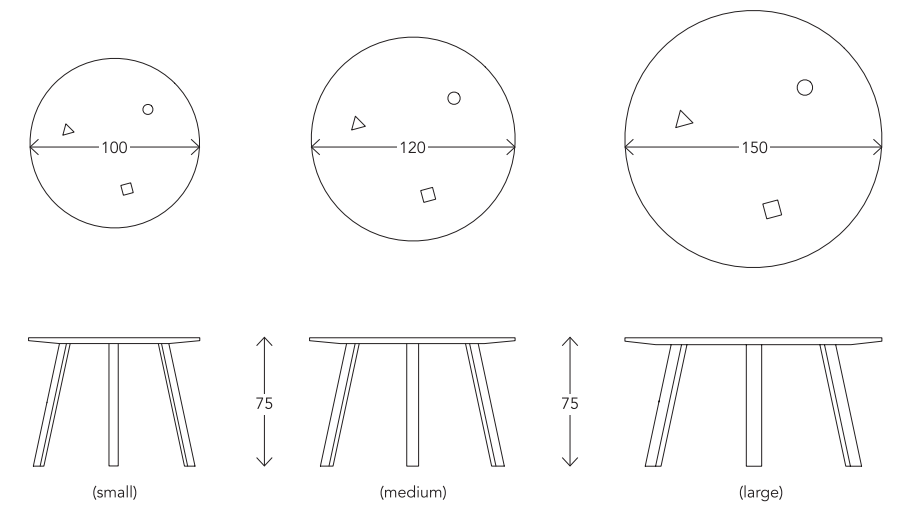

Technical data.

Materials:
Solid wood, solid surface (corian).

Process:
The body and legs of the table are made out of natural oak wood. Table top is handpicked and glued oak timber or made out of solid surface (corian), while table legs are manufactured from solid oak wood. High precision CNC technology is used to cut table legs into geometric shapes to perfectly fit the designated cutaway spaces in the tabletop. Fine sanding and staining is used to complete the design of Euclid.

Table is available in:

- stained solid oak colors*
- 1 - natural oak
 - 2 - light gray
 - 3 - oxford brown
 - 4 - ebony black

Table top is also available in:

- 5 - corian glacier white



Black Mamba

Dining table

As they say – perfection is achieved not when there is nothing more to add, but when there is nothing left to take away – the ideal description of Black Mamba.

It appears subdued if singled out, but just wait for the muscular performance when Black Mamba finds itself in the interior. It is a blow, and definitely below the belt!





Like a strike – a Black Mamba strike – this dining table is monumental.

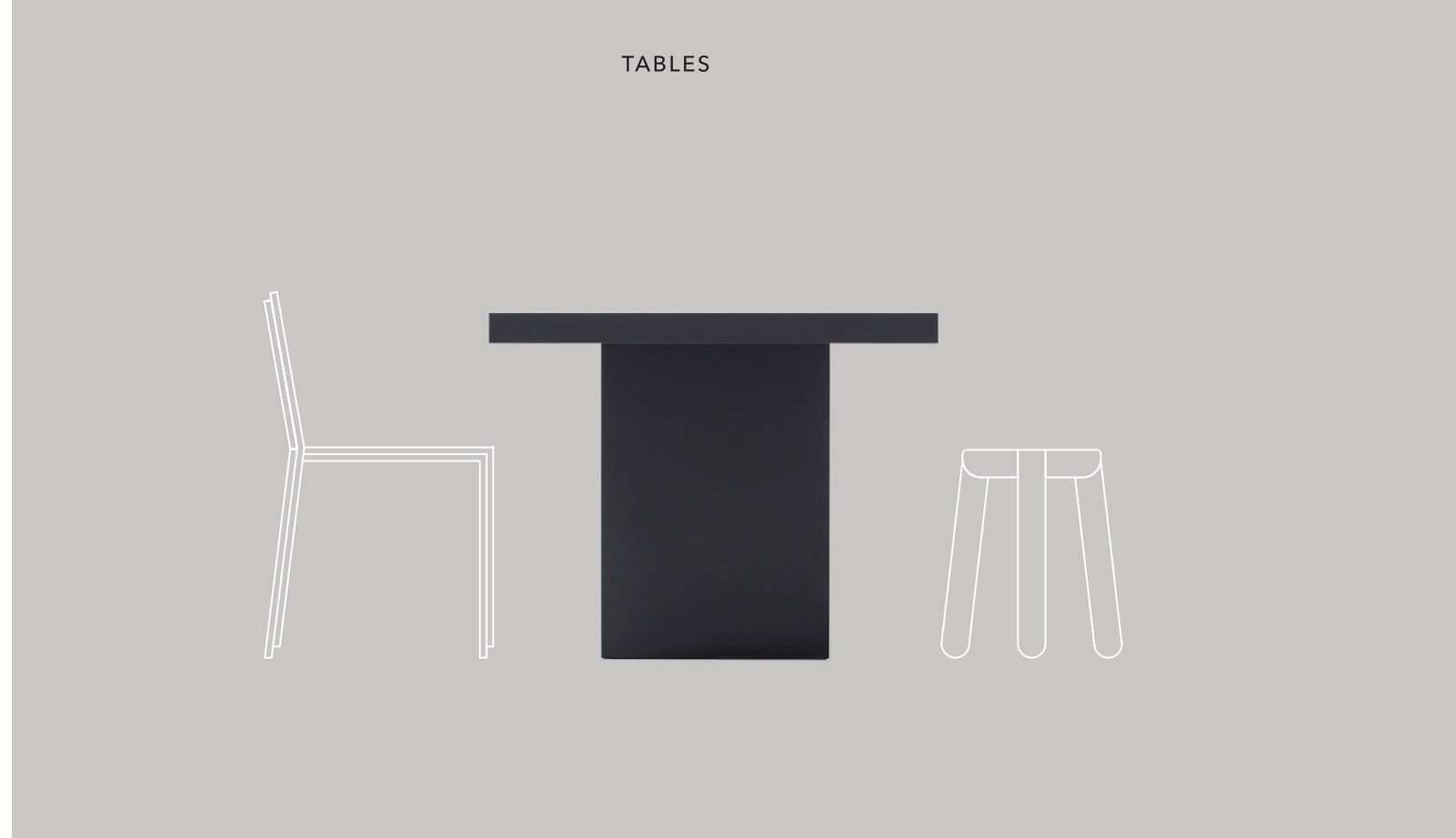

Black Mamba dining table is a living proof that the colossal size and delicacy are effortlessly compatible.

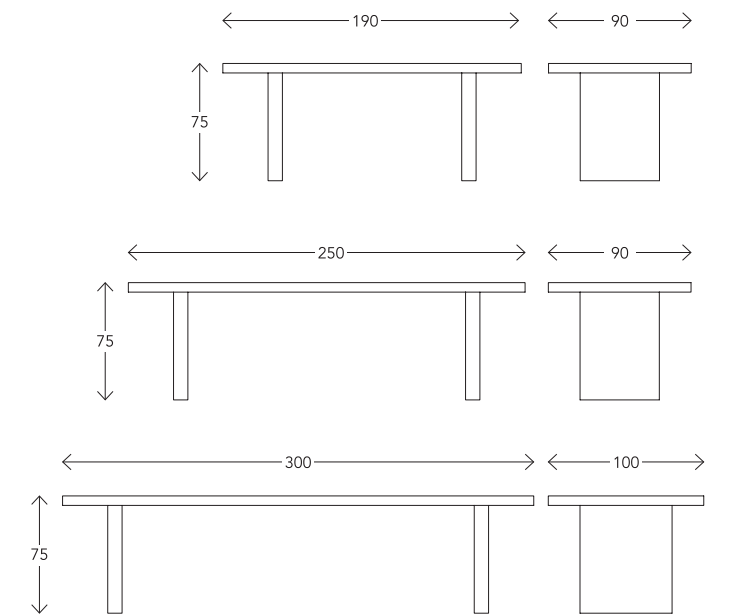

Technical data.

Materials:
MDF board.

Process:
This dining table is made of MDF board, the surface is available in fenix (color: nero ingo - extremely matte) or stained and lacquered natural oak veneer (various colors).

Table is available in:

- | | |
|----------------------------------|---------------------------------|
| <i>stained oak veneer colors</i> | <i>fenix</i> |
| 1 - natural oak | 4 - nero ingo (extremely matte) |
| 2 - light gray | |
| 3 - ebony black | |



Circle of Light pendant lamp

(by Jurgis Garmus)

Lighting

appreciate magnitude

Circle of Light

Pendant lamp



designed by Jurgis Garmus

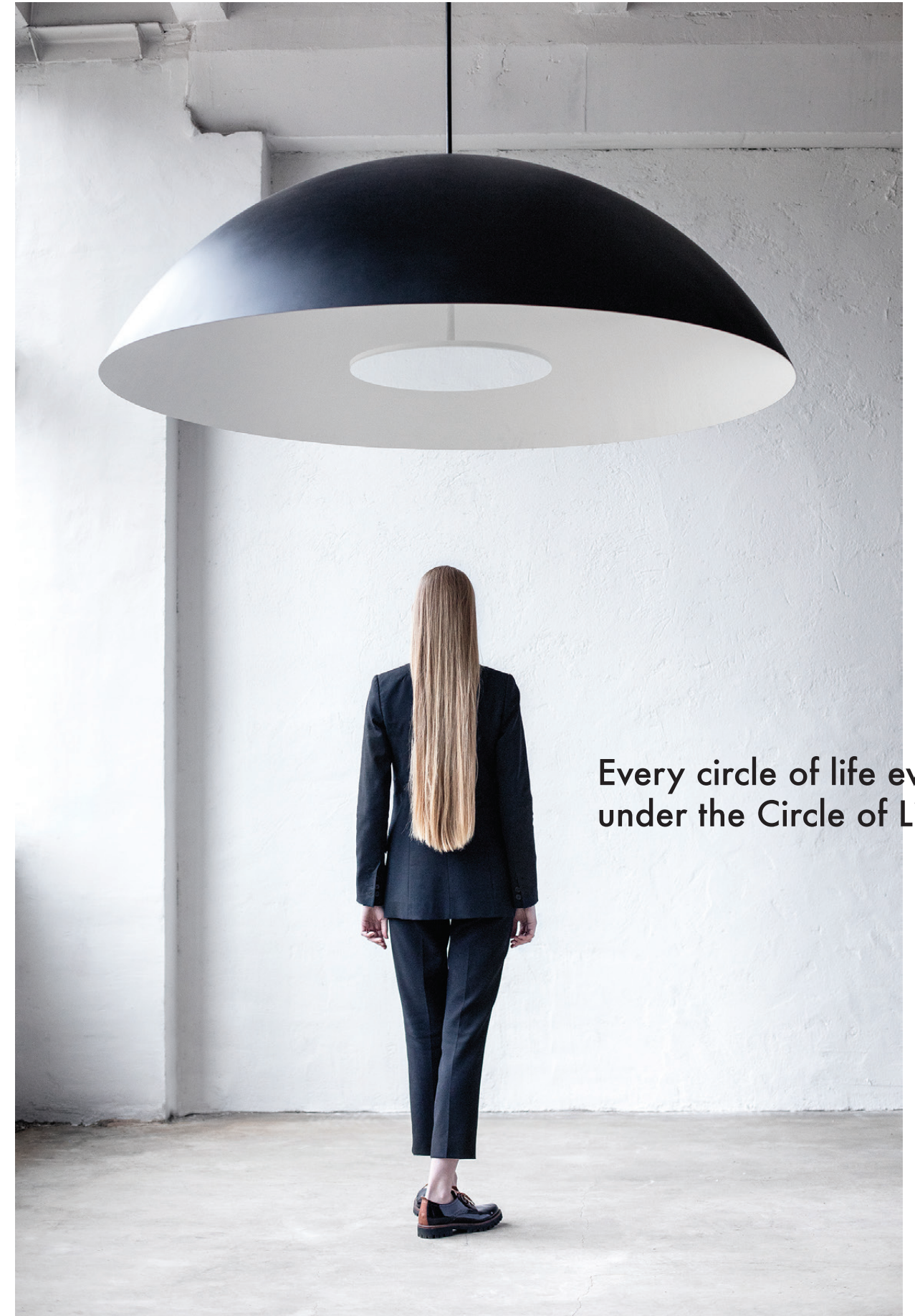

Every circle of life evolves under the Circle of Light.

Circle of Light / d170 / color: black matte.

A Sun or a Star?

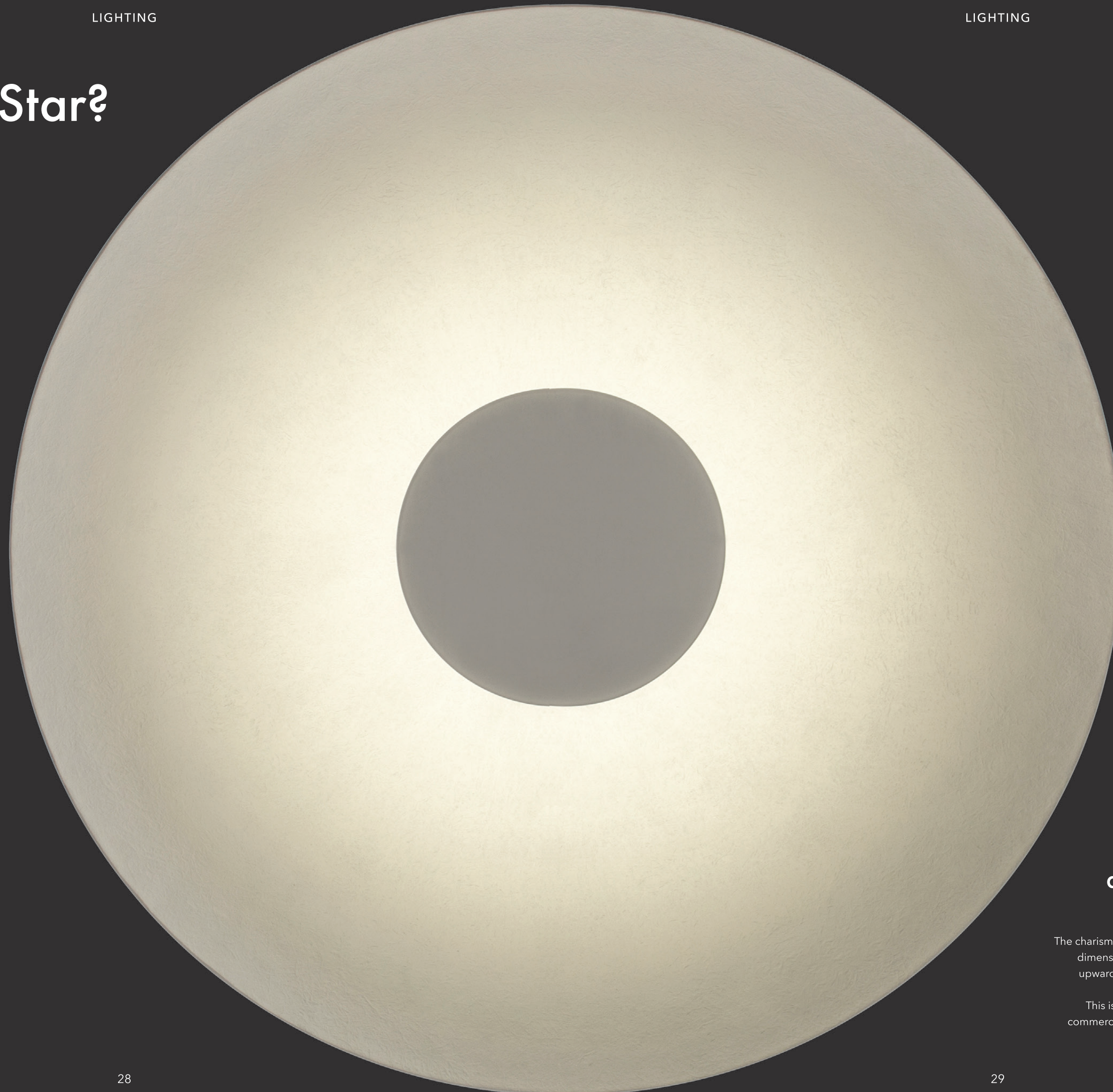

It creates a daring statement if hung alone and blends in perfectly if contextualised.

The charisma of the lamp lies in its celestial silhouette and colossal dimensions. Light beam projected down to the plate bounces upwards and reflects from the cupola, achieving uniform light dispersion and indirect illumination of settings.

This is the reason why Circle of Light perfectly complements commercial as well as residential venues - able to oversee open spaces and be accentuated by them too.

LIGHTING

This charismatic pendant lamp offers you celestial silhouette and colossal dimensions - feeling of space that surrounds us.



LIGHTING



Circle of Light / d170 / color: glossy white.

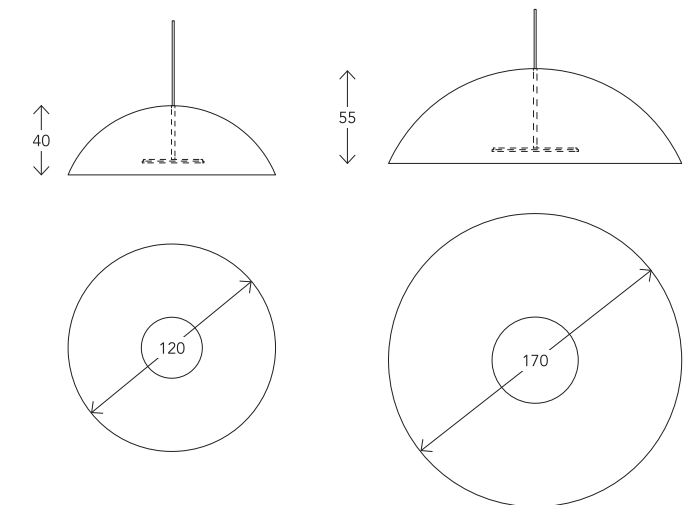

Materials:
Fiber glass dome, painted steel hanging.

Mounting:
Tube hanging system.

Specifications:
Circle of Light has integrated dimmable electronics, enabling dimming from external dimmers and lighting control systems. Reflected light from the inside of dome enlightens softly and evenly.
The light technology is based on a highly energy-efficient, high quality LED solution, which gives a warm white light.
Lightsource: integrated LED
Watt: 65W
Lumen: d120 - 5200 / d170 - 9750
Energy class: A+
Color temperature: 3000K

Outer surface colors (glossy or matte):
1 - white
2 - gray
3 - black

Inner surface color:
4 - rough texture in white.



Technical data.

Shadow chair & barstool

(by Boris Berlin Design)

YAY stool & barstool

(by Gintaras Antanas Kubilius)

Brick family

(by KiBiSi)

BaBa family

(by ISKOS-BERLIN)

Basset family

(by ISKOS-BERLIN)

Roulade sofa

(by KiBiSi)

Seaters

the place to place

Shadow

Chair & barstool

designed by BORIS BERLIN DESIGN



Beauty is not always only skin deep.
A slender wooden chair, simple as a pictogram,
stacked on a metal frame that echoes the shape
of the wooden one like its shadow.

Shadow – a robust stacking side chair and a barstool with the tactile advantages of sitting on the wood, combined with the strength of a steel tube.



The metal frame serves as an exoskeleton, which allows the wooden chair to get this slim.



Yes, it stacks.

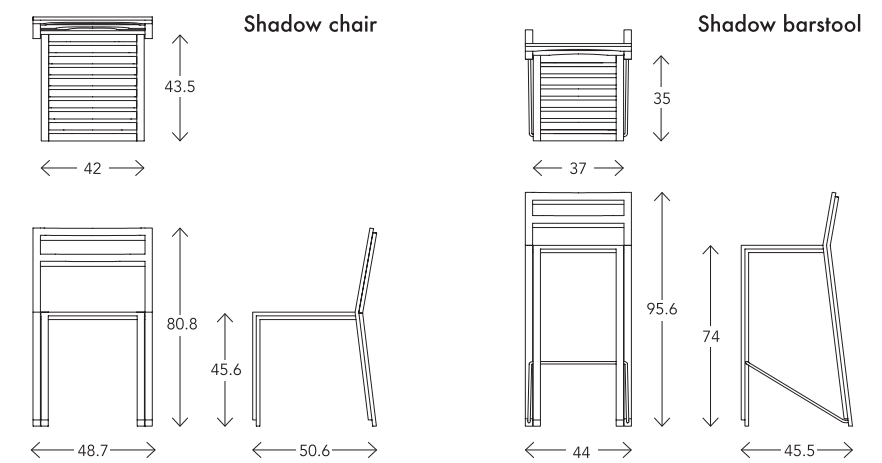

Technical data.

Materials:

Powder-coated steel frame (RAL 9005), oiled or lacquered solid oak wood.

Process:

Laser-cut steel profile is thoroughly welded into a solid monolithic frame, which acts like a bearing construction, while oak wood is processed by using the high precision CNC technology and performs intermediary function between the seater and the steel frame.

Shadow is available in:

Indoors

1 - oil bleached solid oak wood

Outdoors

2 - lacquered, bleached solid oak wood



YAY

stool & barstool



YAY is the reason to look down and smile.

Whoop it up like a child.
This vivacious stool will definitely help you
with that.

The wholeness consisting of soft lines
creates harmonious and cohesive
central space as well as interior accent,
which tends to spread vitality and joy.

YAY says it all.
Nothing left to add. Or to take away.

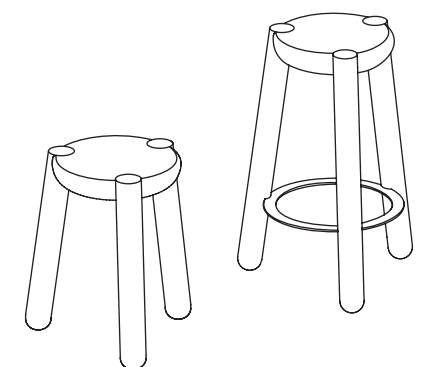



The usage of YAY stool and barstool for the primary purpose is as equally good as for an accessory.



Soft lines and sloping curves make YAY irresistibly pleasant while touching as well as easy on the eyes.

YAY is so much more than a simple Yes.

It is a lively approval of an easy-going design.

It is a celebration of playfulness.

It is an exclamation of joy.

It is here to make you smile.

It is here to make you chuckle.

It is here to make you roar with laughter.

YAY!



YAY stool

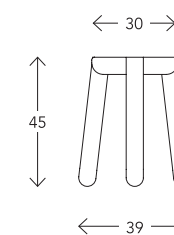

YAY barstool

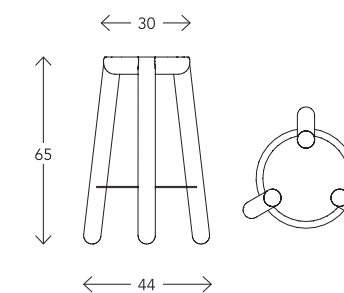

Technical data.

Materials:

Solid wood, painted steel detail (YAY barstool).

Process:

CNC machine-made of solid birch wood.

All the colors are semi-matte.

The foot rail is made of steel in black matte.

YAY stool / barstool is available in:

solid wood enamel paint

1 - white (RAL 9010)

2 - yellow (RAL 1023)

3 - black (RAL 9005)



Brick

Family: pouf, armchair & sofas

designed by KiBiSi



“What is a sofa but a pile of pillows for maximum comfort? Turning the habitual modularity of sofa design into a virtue, the Brick explores the tectonic of bricklaying to stack sandbag-like cushions into architecture for comfort.”

Bjarke Ingels

KiBiSi set out to make a sofa with strong architectural references since KiBiSi partner Bjarke Ingels couldn't really find the right architect's sofa for his apartment.

The point of departure was a classic brick bond forming the cushion pattern.



This architectural sofa is obviously an unparalleled focal point in any modern and contemporary home.

The cushions are tied together and fixed with a tailor quality button, which is molded of fiber concrete – yet another architectural reference.



Brick armchair

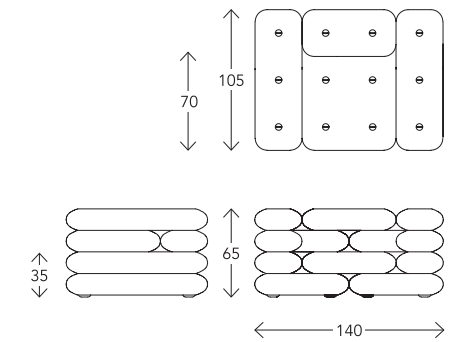

Brick pouf

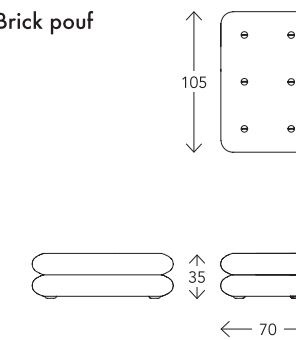

Brick 2-seater sofa

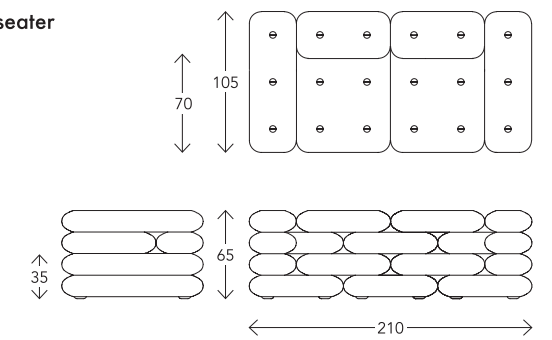

Brick chair

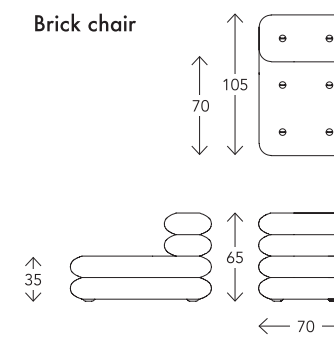

Brick 3-seater sofa

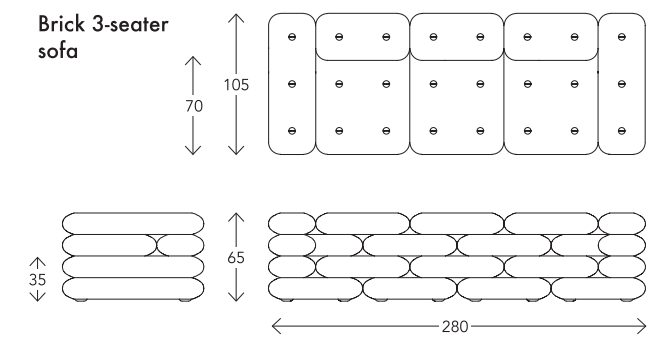
**Materials:**

Natural wool fabric, custom made fiber concrete buttons.

Fabric details:

Designed by Nanna Ditzel for Kvadrat.

Composition: 70% new wool, 30% viscose.

Environment: complies with EU Ecolabel. Long life span.

Benefits of wool: wool is a renewable resource and ages with grace.

Abrasion: approximately 100.000 Martindale rubs, EN ISO 12947.

Process:

Sandbag-like cushions made of upholstered foam. Bricklaying design fixed up with tailor quality buttons made of fiber concrete and tied with a rope.

Technical data.

Button rope options:

- 1 - sky blue
- 2 - ebony black

Textile upholstery options:

- 3 - Hallingdal 65-110
- 4 - Hallingdal 65-130
- 5 - Hallingdal 65-180

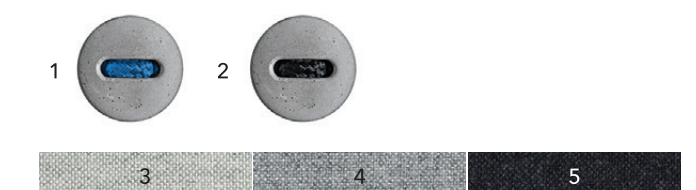

B a B a

Family: pouf, easy chair & sofa

designed by ISKOS - BERLIN



BaBaBa 3-seater sofa - for you and the other two.
Gracefully sculpted sofa is undeniably in a class of its own.



BaBa easy-chair is an organic soft-formed "furniture pet" that invites you to cuddle up to it, sit on it or sink into its warm embrace.

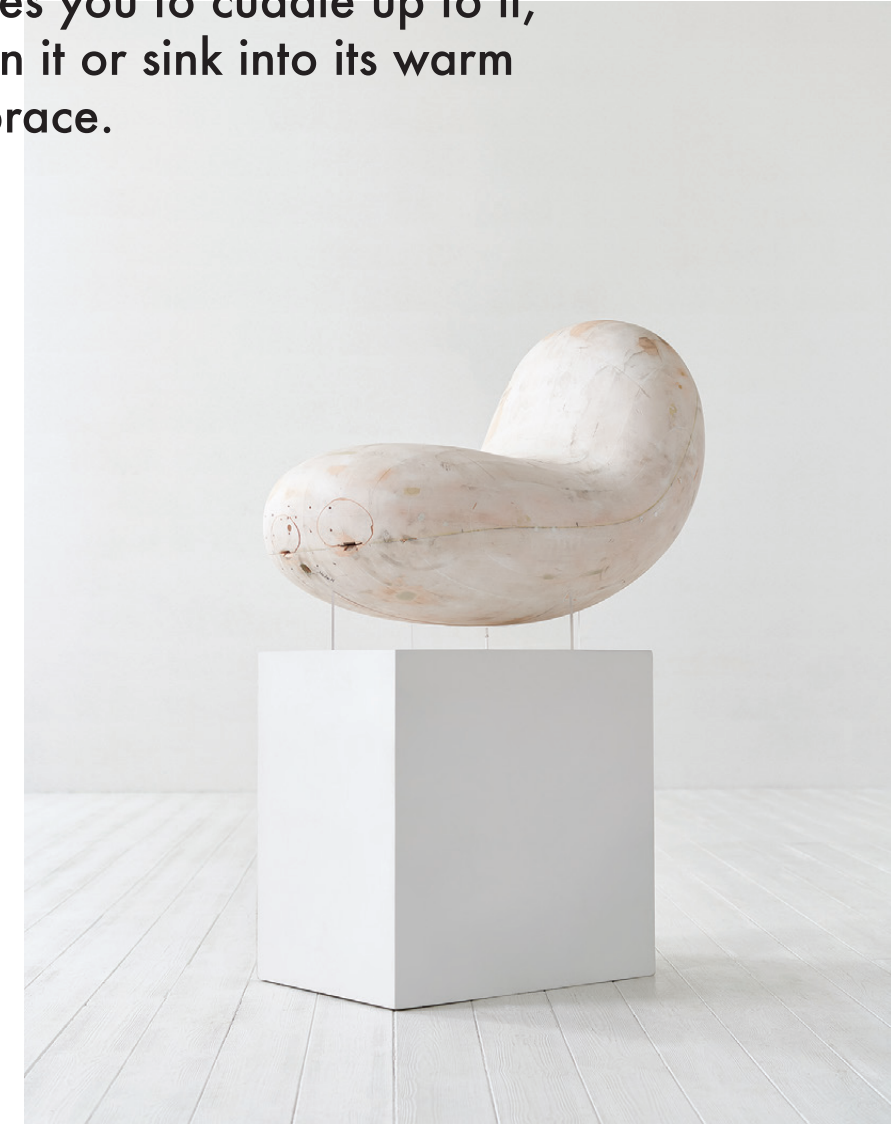

"It is a strange love. Though I'm not the biological father of this creation, I couldn't love it more. In all of the process I was more or less just the accoucheur. But after seeing its selfless act of kindness to donate itself for the brutal BaBa mass production tool's delivery operation, with all the cracks, scars and wounds, it became my precious, unique piece of foam. Which laid the foundations for the flawless continuation. Some might accept this piece of foam as an irrelevant waste. But my attachment and appreciation pushed me to build its own stage for everyone to see the greatest strength in sacrifice."

Jurgis Garmus, CEO



3D-knitted fabric was specially modified for the project. This textile is exceptionally stretchy which offers a high degree of flexibility.

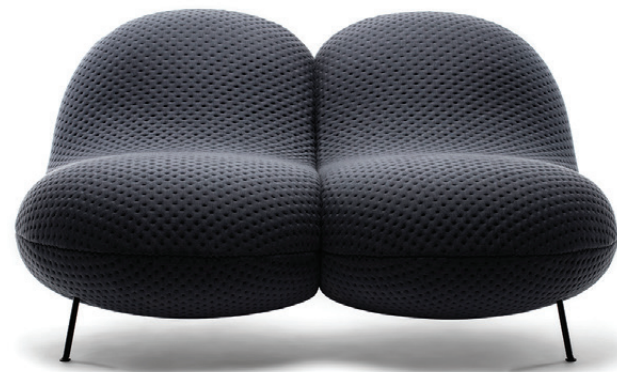

Slim, graceful and elegant steel legs bring distinction to the uniquely formed soft roundness of the body.

BaBaBa therapy for your physical and emotional comfort.



Sometimes more is less.
Extra seating for the comfort of
your guest – less worries for you.



Ba pouf

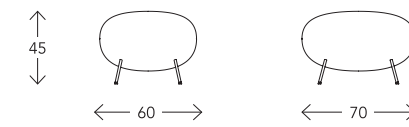

BaBa easy chair

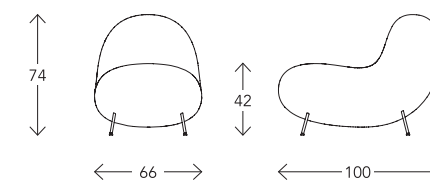

BaBaBa 2-seater sofa

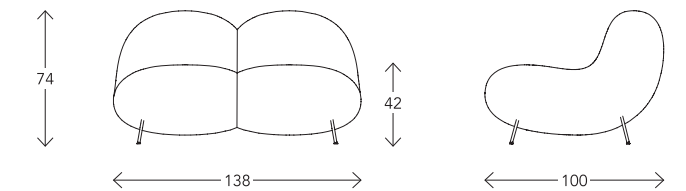

BaBaBa 3-seater sofa

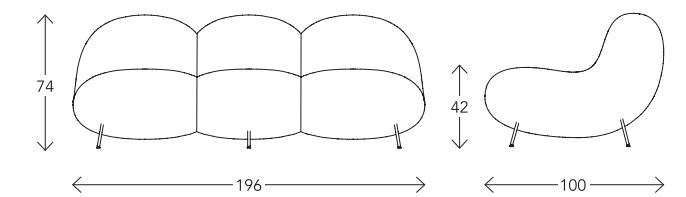
**Materials:**

Fabric, painted steel legs, the shell is made from casted foam.

Process:

The production process extensively employs the latest technologies, starting from CNC milling while making a mould to using casted foam to fill the Bababa's body. Easily adjustable density, flexibility and hardness of casted foam guarantees the greatest sitting comfort, whereas the highest level of durability helps to maintain the original shape and quality. Inner frame and legs are made of steel with powder-coated surface.

Fabric details:

Designed by Febrik.

Composition: top layer 75% wool / 25% synthetics.

Environment: Oeko-Tex® standard 100. All chemicals used are registered under the REACH legislation ecologically produced in the Netherlands.

Textile upholstery options:

- 1 - STITCH Rouge
- 2 - STITCH Earth
- 3 - STITCH Graphite



Basset

Family: pouf, armchair & sofa

designed by ISKO



Basset's sculptural language is simple and clear.

There are just two elements - a horizontal "pillow" for a seat and a vertical "duvet" at the back that wraps around the seat, embracing it from the sides.



Basset armchair



Basset 2-seater sofa



Basset pouf



Basset 2.5-seater sofa



Basset armchair



Basset 3-seater sofa



Basset doesn't demand much space and fits easily into smaller rooms. Upholstery details - marked piping is used to accentuate its shape in a natural way, giving it an easily recognizable design "signature".



Basset pouf

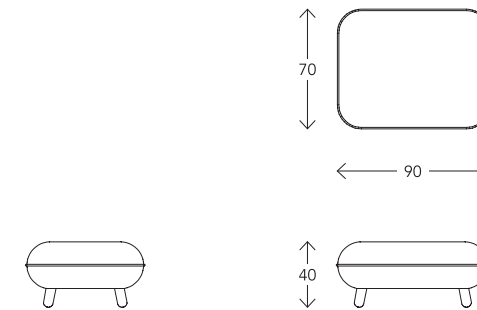

Basset armchair

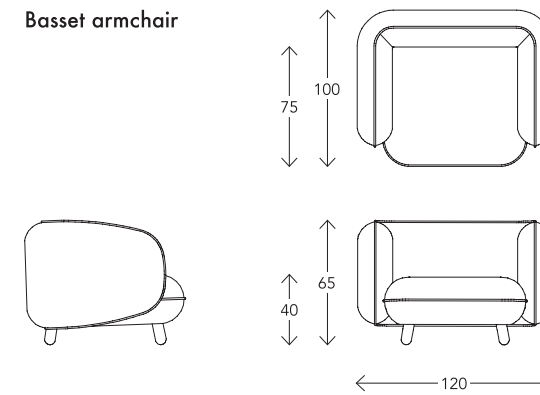

Basset 2-seater sofa

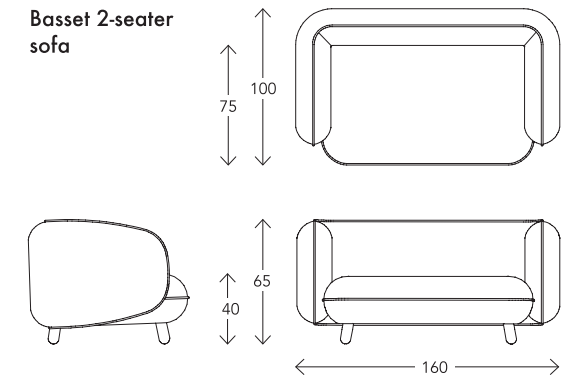

Basset 2.5-seater sofa

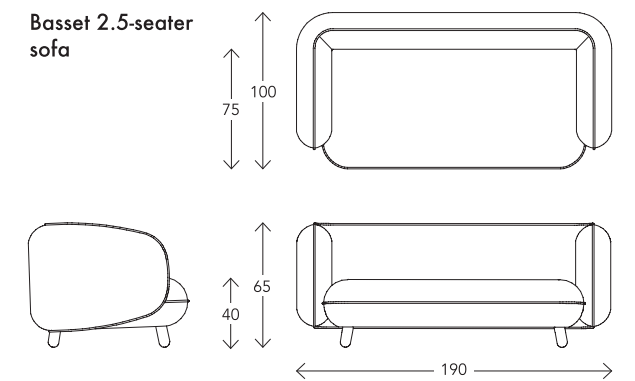

Basset 3-seater sofa

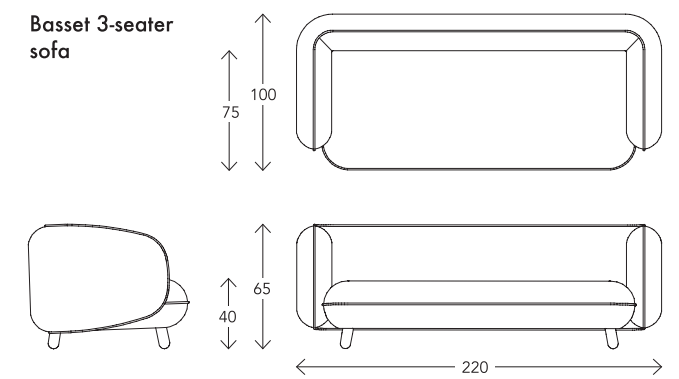

Materials:

Natural wool upholstery, natural oak legs.

Fabric details:

Designed by Nanna Ditzel for Kvadrat.
Composition: 70% new wool, 30% viscose.
Environment: complies with EU Ecolabel. Long life span.
Benefits of wool: wool is a renewable resource and ages with grace.
Abrasion: approximately 100.000 Martindale rubs, EN ISO 12947.

Process:

BASSET is constructed and produced following the finest traditions of craftsmanship for this type of furniture.
Marked piping is used to accentuate its shape in a natural way, giving it an easily recognizable "signature" design.

Technical data.

Legs are available in colors:

a - natural oak
b - black stained oak

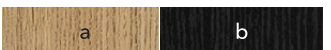

Textile upholstery options:

Different textile colors can be combined for the front and back sides of the product.

- | | |
|-----------------------|-----------------------|
| 1 - Hallingdal 65-110 | 2 - Hallingdal 65-687 |
| 3 - Hallingdal 65-180 | 4 - Hallingdal 65-457 |
| 5 - Hallingdal 65-130 | 6 - Hallingdal 65-944 |
| 7 - Hallingdal 65-960 | 8 - Hallingdal 65-754 |
| 9 - Hallingdal 65-143 | |

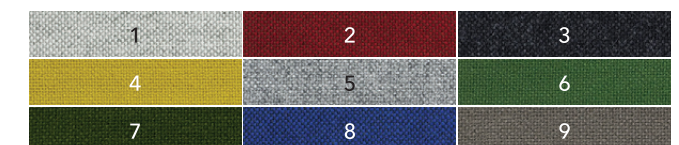

Roulade

Sofa

designed by KiBiSi



Always on the playful move,
always rolling forward.

Roulade is a Swiss Roll turned sofa – a
contemporary, iconic and humorous character with a
cozy and comfortable expression.



Roulade - echoes the old while channelling the new.

It is a meeting between generations and genres, a meeting between mattress and Chesterfield, chair and couch.

Technical data.

Materials:

Upholstered high density foam, bespoke buttons.

Fabric details:

Designed by Nanna Ditzel for Kvadrat.

Composition: 70% new wool, 30% viscose.

Environment: complies with EU Ecolabel. Long life span.

Benefits of wool: wool is a renewable resource and ages with grace.

Abrasion: approximately 100.000 Martindale rubs, EN ISO 12947.

Process:

Roulade is made from high density foam cut into a fixed shape reminiscent of a rolled-up mattress. It is upholstered with top class materials such as Kvadrat fabrics; the comfort and durability is outstanding. It is a sort of newcomer - a plump 1,5 pax sofa designed for laid-back hangout. Bespoke oversized buttons modernize the old-school Chesterfield expression.

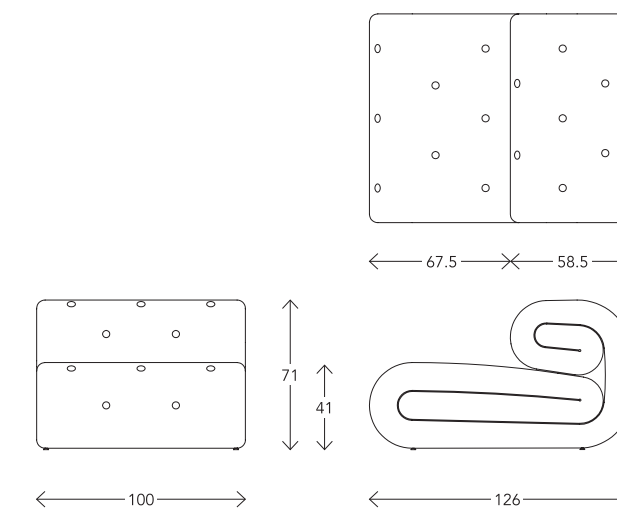

Textile upholstery options:

1 - Hallingdal 65-810
3 - Hallingdal 65-687
5 - Hallingdal 65-680
7 - Hallingdal 65-457
9 - Hallingdal 65-754

2 - Hallingdal 65-180
4 - Hallingdal 65-960
6 - Hallingdal 65-944
8 - Hallingdal 65-143

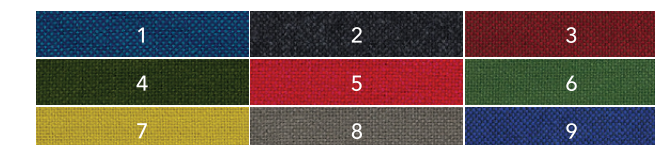

Mudu mirror	<i>(by HEIMA architects)</i>
Frame coat rack	<i>(by Mattias Stenberg)</i>
Let's play rug	<i>(by Inga Liksaite)</i>
Piano album cover rug	<i>(by Karolis Strautniekas)</i>
Harlequin rug	<i>(by OKIIKO studio)</i>
Six seasons rug	<i>(by OKIIKO studio)</i>
Psychoanalysis rug	<i>(by OKIIKO studio)</i>

Accesso- ries

mind the details



Mudu

Mirror

The touch of precision down to the last detail.

designed by HEIMA architects

MUDU – it's about two of us –
Me and my Reflection.



The conical silhouette changes with a different viewing angle.
Wooden details are repeated on the base as well as on the frame legs.
The touch of precision down to the last detail.

The better I look, the better my Reflection looks. Yet still over the years I have discovered – the first step to looking elegant in a mirror is looking at an elegant mirror.

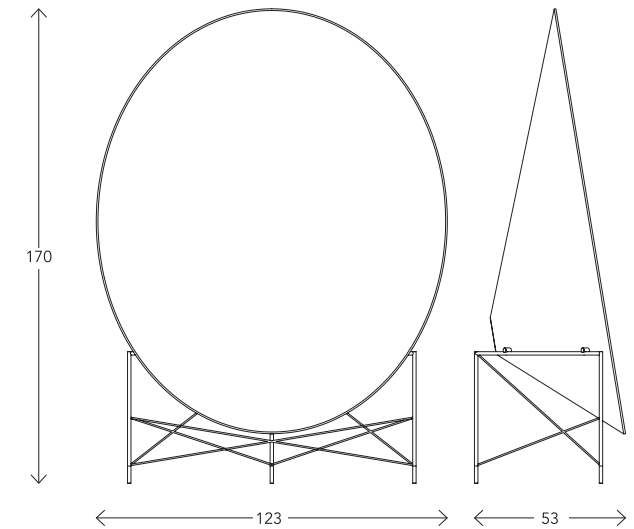

Technical data.

Materials:
Solid surface (corian), mirror, steel, solid oak details.

Process:
The production process of the mirror extensively uses latest technologies such as vacuum thermoforming and CNC milling. Corian was heated till flexible and placed on CNC milled conical shell mould with a vacuum press. Wooden pegs set in the side of the mirror's shell allow it to rest atop a painted steel framework, which also has wooden accents at the base of its legs.

Mirror body:
1 - Corian glacier white

Steel framework:
2 - painted steel (RAL 9010)
3 - painted steel (RAL 9005)

Wood details:
4 - solid oak





Frame

Coat rack

This functional coat rack is a strong graphic feature in any environment, but at the same time transparent enough to make a light and airy impression. Frame - holds not only your clothes, but also - almost ceremoniously - the stone or wooden bowl, that keeps the smaller items right where they belong.

Free your mind from frame with Frame.



designed by Mattias Stenberg





A structure to hold your clothes and everyday objects.
With the stone bowl in the lower position, it becomes a rain water collector for wet umbrellas.

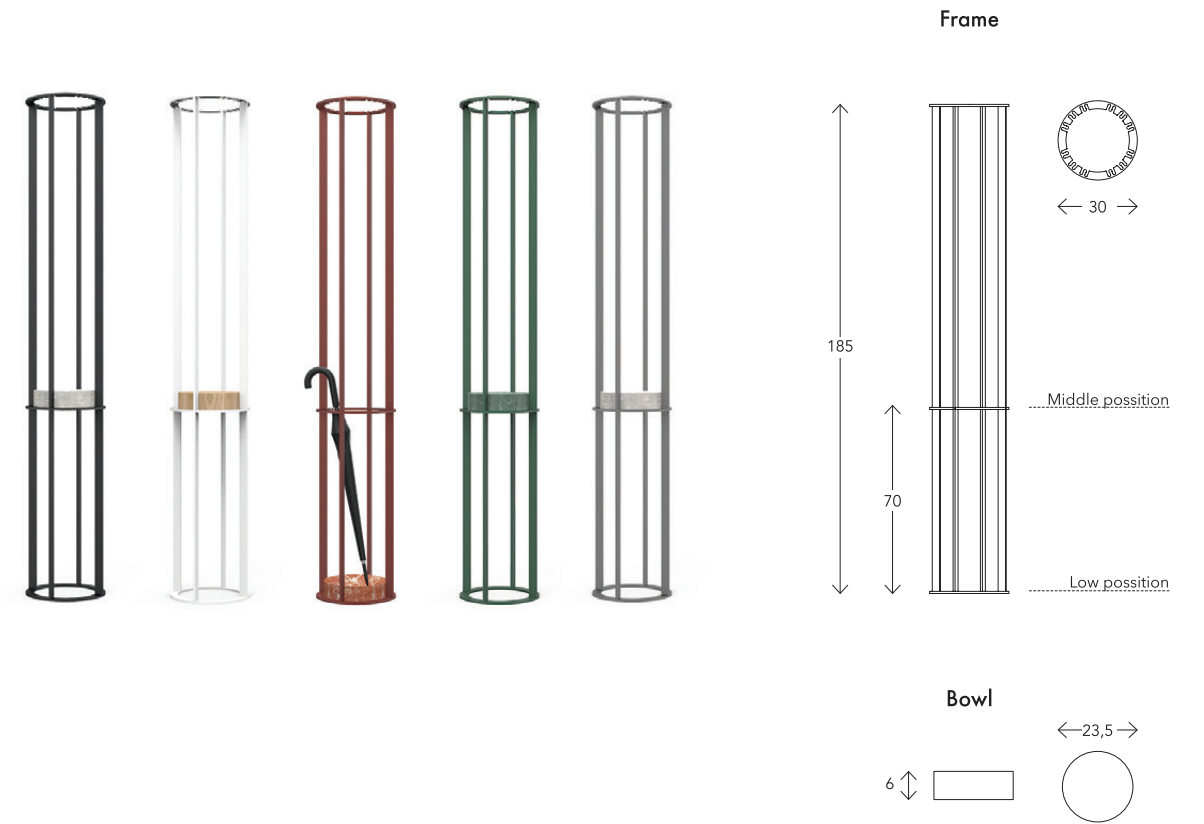

Technical data.

The coat rack is available in two options:
a - The stone bowl in the lower position.
b - The wooden or stone bowl in the middle position.

Materials:
Steel, natural stone or oak wood.

Process:
Frame production involves the sheet metal laser cutting, welding and powder coating.
Natural stone and oak wood bowls are made by using the CNC milling machine.

Frame is available in colors:

- 1 - white (RAL 9010)
- 2 - gray (RAL 7030)
- 3 - red (RAL 3009)
- 4 - green (RAL 6028)
- 5 - black (RAL 9005)

Bowl is available in:

- stone / wood
- 6 - Bianco Carrara
- 7 - Jura blue grey
- 8 - Rosso Collemandina
- 9 - Verde Guatemala
- 10 - natural oak



Let's play

Rug

To put things apart, to observe, to set up the elements again.

designed by Inga Liksaite

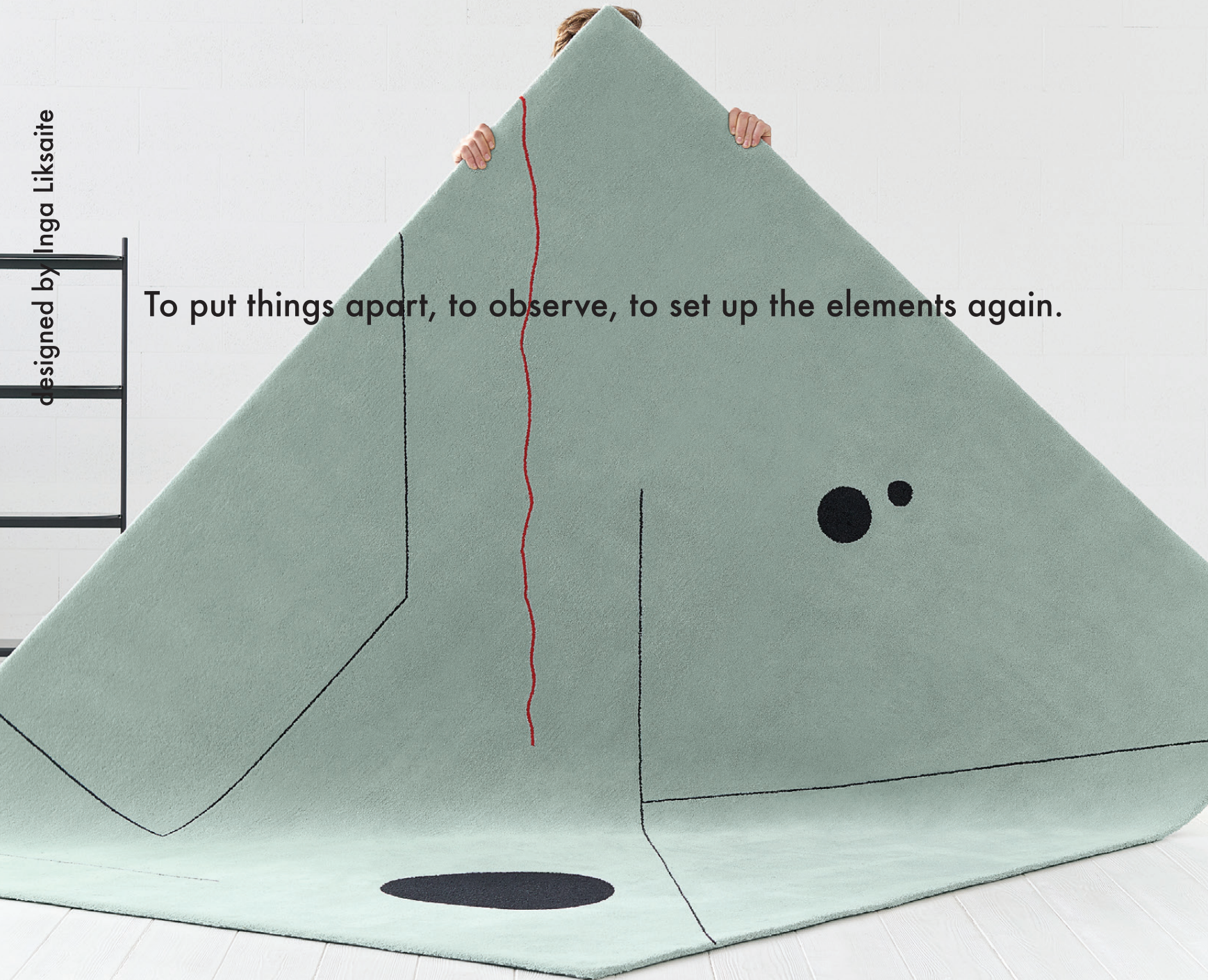

Let's play

One's head is full of different ideas and there are innumerable variations for every situation. Let's be open, let's play, let the mind distinguish the essence and find the pure solution for every moment of life.

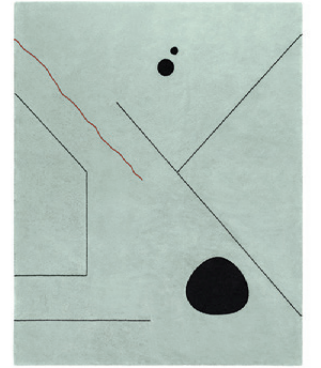

Technical data.

Technique:
Tufting.

Pile height:
14mm (cut).

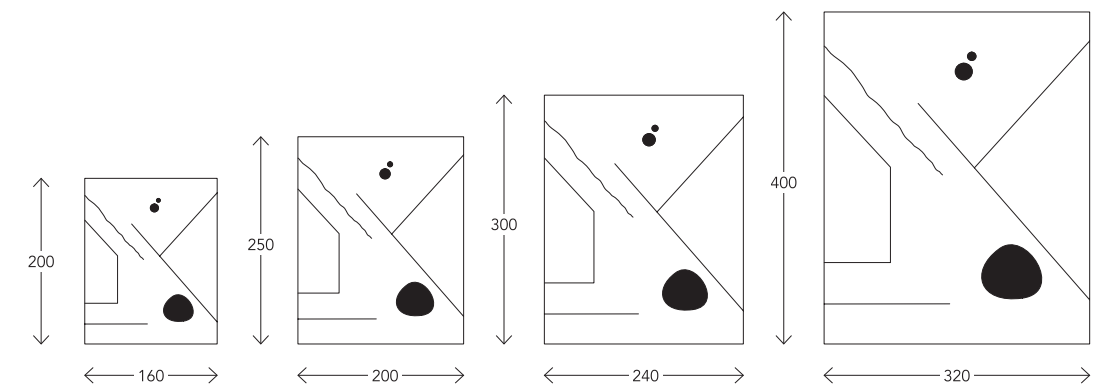

Materials:
New Zealand 100% wool.

Properties:
Area rug as well as wall-to-wall carpet, both for private and public interiors. 100% wool carpets have been assigned with fire behaviour classification CfI-s1 and meet requirements presented to hotels and other public spaces.



Piano album cover
designed by
Karolis Strautniekas
"Feel the music with every step
you take."

Rug

designed by Karolis Strautniekas



Feel the music with every
step you take.

Statement-making design leaves no
one indifferent. The vivid, lush and
dominating color of rust orange is
soothed by an earthy colored center
element in charcoal.



Technical data.

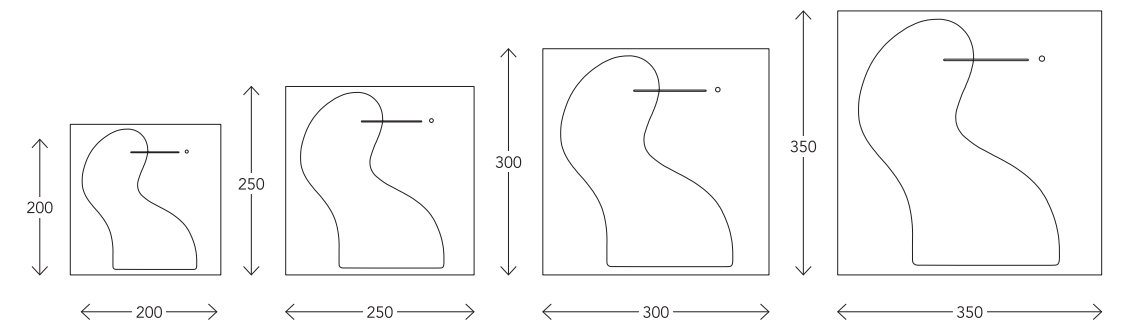

Technique:
Tufting.

Pile height:
14mm (cut).

Materials:
New Zealand 100% wool.

Properties:
Area rug as well as wall-to-wall carpet, both for private and public interiors. 100% wool carpets have been assigned with fire behaviour classification Cf1-s1 and meet requirements presented to hotels and other public spaces.

Harlequin

Rug

designed by OKIICO studio



Harlequin -
a graphic acrobat to
entertain your home.

Harlequin adds brightness, charm and
amusement to your soul and home.

Increased attention to graphics,
material and colors brings the most to
your senses and feelings.

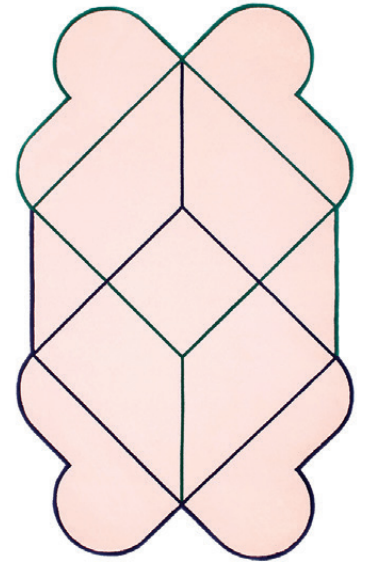

Technical data.

Technique:
Tufting.

Pile height:
14mm (cut).

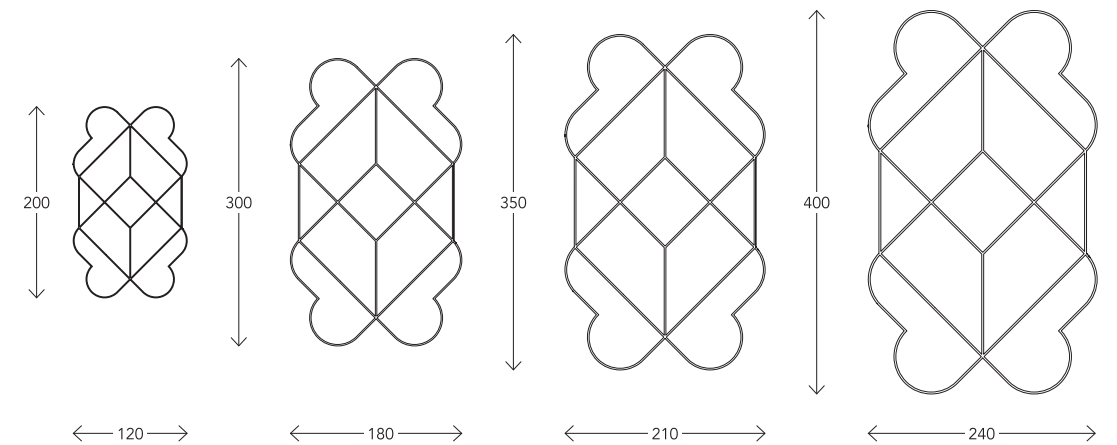

Materials:
New Zealand 100% wool.

Properties:
Area rug as well as wall-to-wall carpet, both for private and public interiors. 100% wool carpets have been assigned with fire behaviour classification CfI-s1 and meet requirements presented to hotels and other public spaces.

Six seasons

Rug

designed by OKIILKO studio



Six Seasons – extended outdoor moments at home.

Six seasons.
Six colors.
Six moods.



Six seasons. And all of them are equally good.
So choose yours.

Technical data.

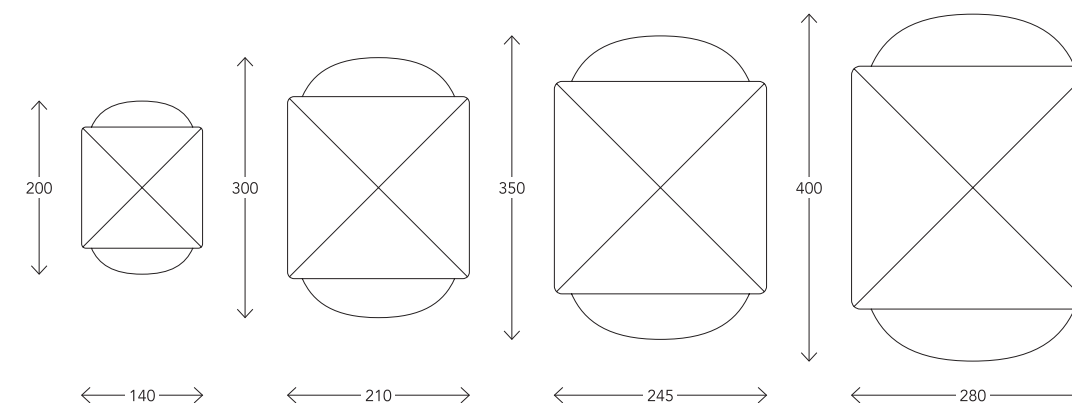

Technique:
Tufting.

Pile height:
14mm (cut).

Materials:
New Zealand 100% wool.

Properties:
Area rug as well as wall-to-wall carpet, both for private and public interiors. 100% wool carpets have been assigned with fire behaviour classification Cfl-s1 and meet requirements presented to hotels and other public spaces.

Psycho-analysis

Rug



Take a moment to relax and to know yourself better.

Unique,
extraordinary,
expressive
and made out of wool.
All of that in one rug.
Psychoanalysis rug.

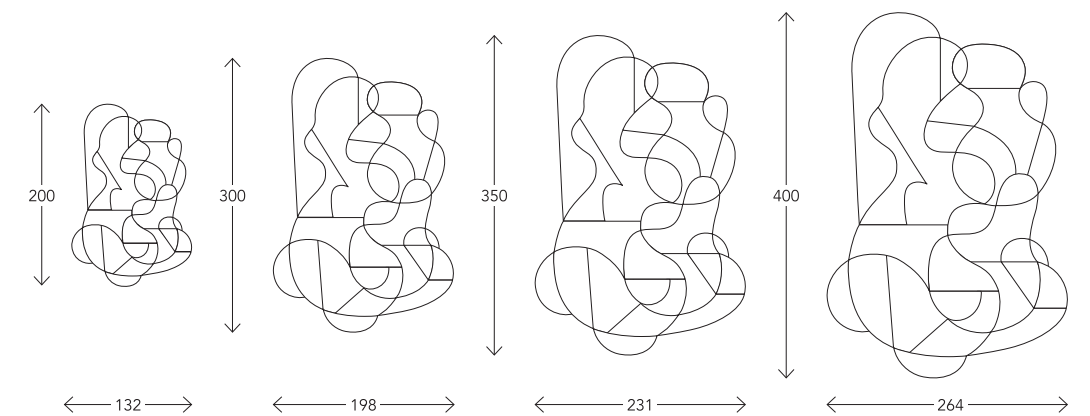

Technical data.

Technique:
Tufting.

Pile height:
14mm (cut).

Materials:
New Zealand 100% wool.

Properties:
Area rug as well as wall-to-wall carpet, both for private and public interiors. 100% wool carpets have been assigned with fire behaviour classification CfI-s1 and meet requirements presented to hotels and other public spaces.

Cross shelving system

(by etc.etc.)

Oba storage units

(by HEIMA architects)

Storage

hide - and - seek

Cross

Shelving system

designed by etc.etc.



**Cross – a stylish residence
for your lovely items with a
very long shelf life.**

The Cross shelving system contains minimal, graphic, and transparent construction, produced with high accuracy, and can be used against the wall or even as a room divider. Design, that perfectly interacts with various spaces and suits the interior of every home or office, was inspired by multiplane aircraft models.



Light and airy shelves are to store and display, where things feel comfortable and appreciated.

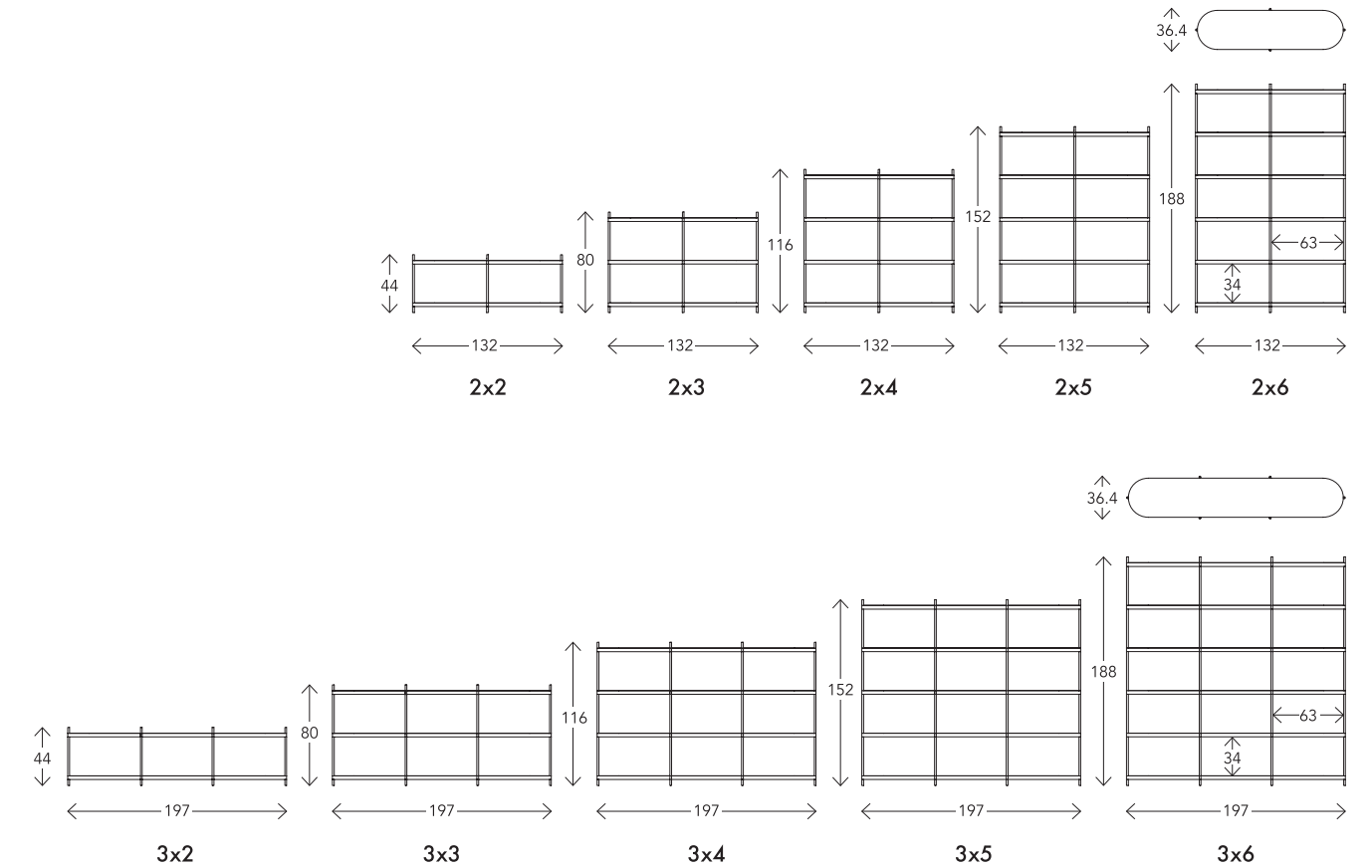

Technical data.

Materials:

Powder-coated steel frame, veneered or painted MDF.

Process:

User-friendly assembly with no tools or screws required, as it is held together simply by gravity. Powder-coated steel frame and CNC milled MDF board, which comes in two options: painted or lacquered veneer. Modules configurable to various lengths and heights. Legs can be adjusted to fit uneven floors.

Cross is available in colors:

- 1 - white (RAL 9010)
- 2 - gray (RAL 7030)
- 3 - red (RAL 3009)
- 4 - black (RAL 9005)

Additional options for shelves:

- 5 - natural oak veneer
- 6 - painted oak veneer in colors (1,2,3,4)



Oba

Storage units

designed by HEIMA architects

Oba is defined by lines.

The line of silhouette gently bends over the corner.

The lines of the façade create a uniform pattern.

The lines of the legs detach the volume from the ground.

The line of a handle gives the last accent and a finishing touch.



Oba -
the perfect home
for the things you love.



Hide your items
and secrets in style.

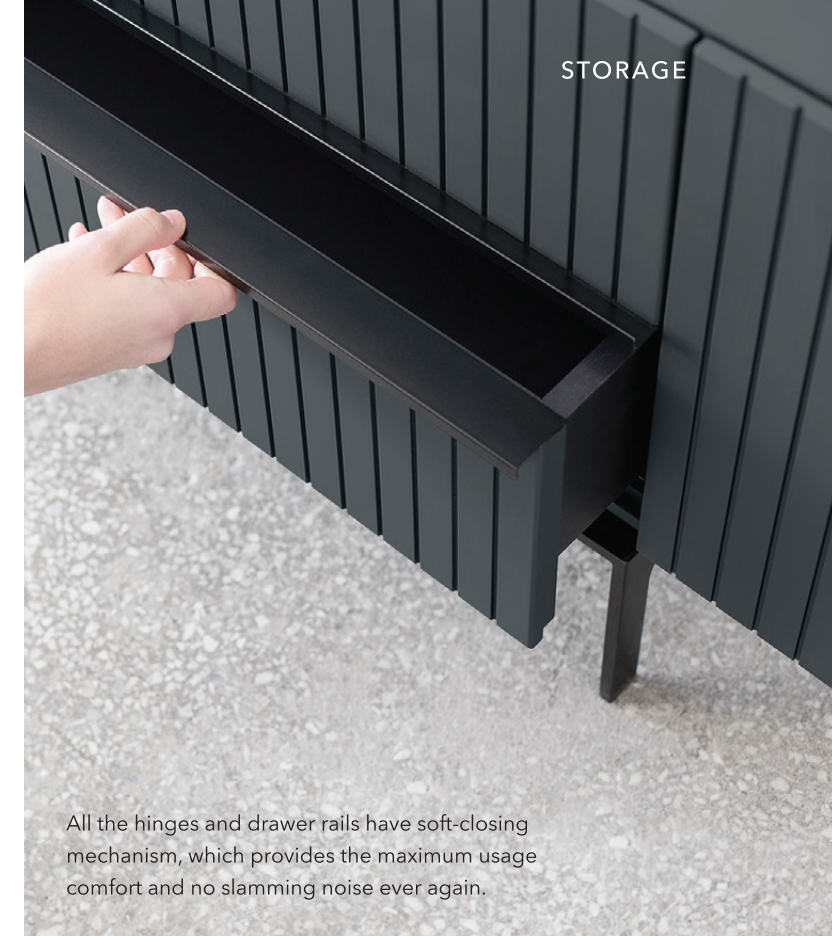

All the hinges and drawer rails have soft-closing mechanism, which provides the maximum usage comfort and no slamming noise ever again.

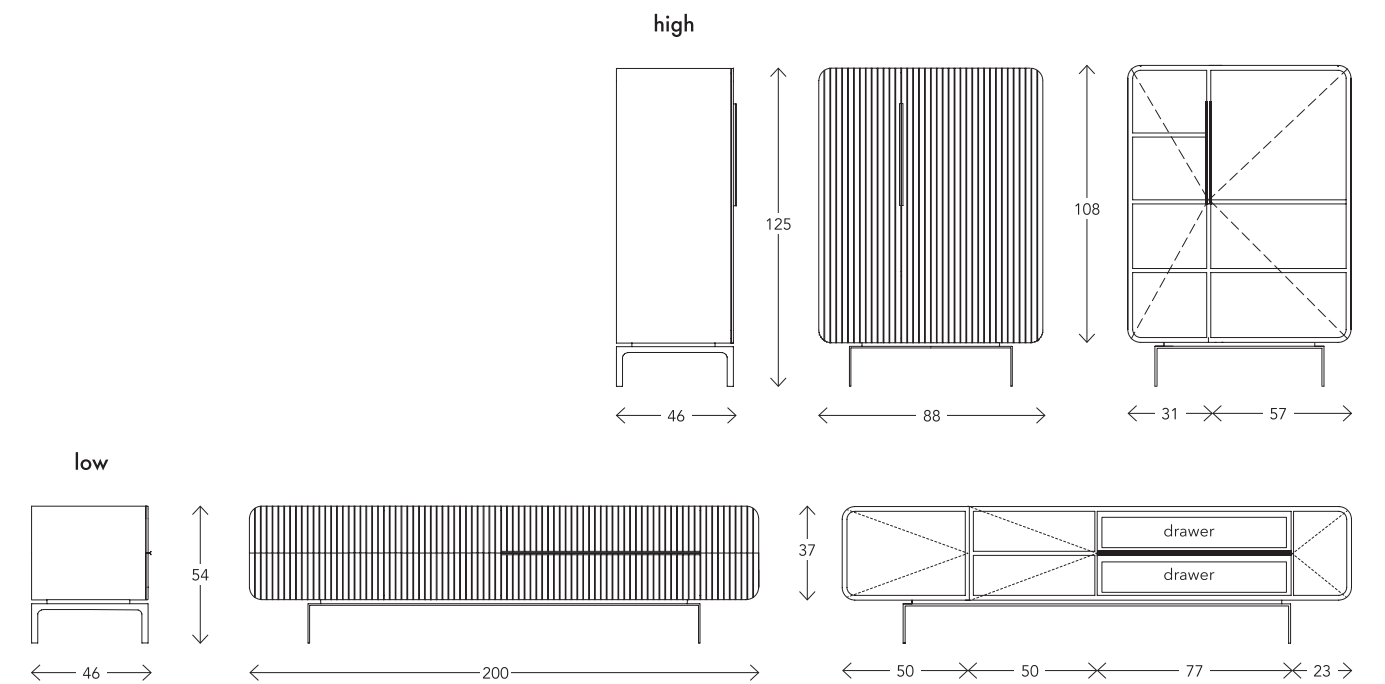

Technical data.

Materials:

Painted and lacquered MDF board, painted steel handles and legs.

Process:

Fiber boards are milled and sanded to achieve smooth painting and flawless design. Oba storage unit features powder-coated steel legs and high quality soft-closing fittings.

Oba is available in colors:

- 1 - white (RAL 9010)
- 2 - gray (RAL 7031)
- 3 - red (RAL 3009)
- 4 - green (NCS S 7010-B90G)
- 5 - black (RAL 9005)



Main photography:

Shoop.lt
Ignas Maldus

Additional photos:

Lina Adi Photography
Lukas Mykolaitis

Editorial design:

Aiste Tarutyte

Head office:

Drobes st. 66,
45181 Kaunas, Lithuania

Sales inquiries

Tel: +37061203846
sales@jotjot.com

General inquiries

Tel: +37061610039
info@jotjot.com
<http://www.jotjot.com>

facebook: jotjot

instagram: jot.jot_design

LET EMOTIONS THINK.