

# GOLD VIBES

Interiors



**LEDS C4**







# H

Benedito Design



(IT) La collezione di apparecchi di illuminazione H nasce come reinterpretazione contemporanea della classica lampada da tavolo, con paralume conico. Con geometrie essenziali e archetipiche, spiccano la leggerezza del suo paralume e quella della sua sorgente luminosa, poggianti sulla base di un generoso diametro che fornisce confezione e solidità all'insieme. La sua luce indiretta inferiore e superiore fornisce un'illuminazione confortevole e calda, evidenziando lo spazio che la circonda.

Questa collezione offre una vasta gamma di possibilità per illuminare gli spazi in modo delicato, attraverso pezzi che offrono un grande valore rappresentativo e un'importante coerenza generale.

Informazioni tecniche pag. 34/39

(FR) La collection de luminaires H est née comme une réinterprétation contemporaine de la lampe de chevet avec abat-jour conique classique.

Aux géométries essentielles et archétypales, la légèreté de son abat-jour et celle de sa source lumineuse sont mises en évidence, reposant sur un socle au diamètre généreux qui assure élégance et solidité à l'ensemble. Sa lumière indirecte, inférieure et supérieure, offre un éclairage confortable et chaleureux, qui met en valeur l'espace autour de lui.

Cette collection offre un large éventail de possibilités pour éclairer les espaces délicatement, grâce à des pièces qui apportent une valeur représentative importante, mais aussi une grande cohérence de l'ensemble.

Information technique p. 34/39









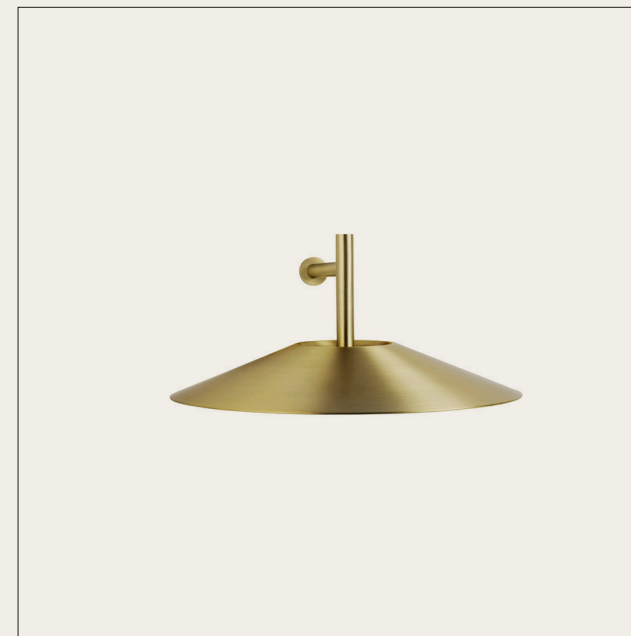
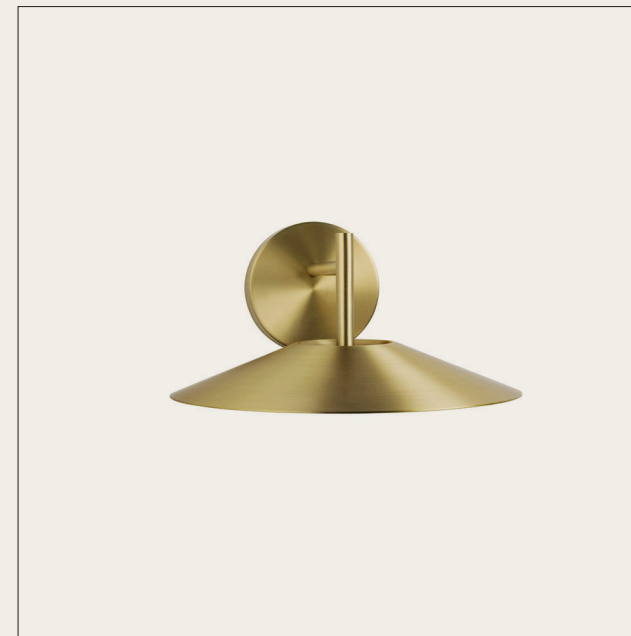

(IT) Diverse opzioni di installazione.

(FR) Différentes options d'installation.



# Gamma

Josep Patsí



(IT) Gamma è un'ampia collezione appositamente progettata per il settore dell'hospitality, con una moltitudine di formati e possibilità. Questa collezione con un design contemporaneo si distingue per le eccellenti finiture e la grande flessibilità che offre.

La lampada da tavolo, a sua volta, è alla ricerca di una versione molto minimalista per la luce del desktop.

**Informazioni tecniche pag. 35/38**

(FR) Gamma est une vaste collection spécialement conçue pour le secteur hôtelier, qui offre une multitude de modèles et de possibilités. Cette collection au design contemporain se distingue par ses excellentes finitions et sa grande flexibilité.

Quant à la lampe de table, elle vise à trouver une version très minimaliste pour l'éclairage du bureau.

**Information technique p. 35/38**







Formati / Différents modèles

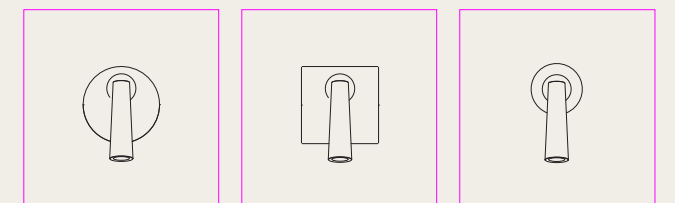

Combinazioni possibili (alcuni esempi):  
Combinaisons possibles (quelques exemples):

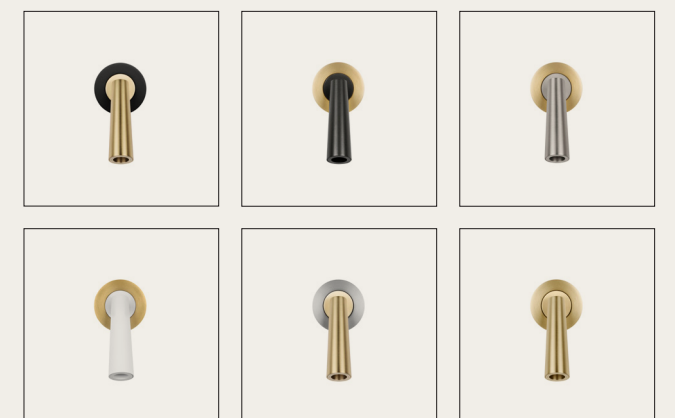



# Napa

Nahtrang Studio



(IT) Di ispirazione scandinava, Napa ha una struttura di forme semplici e sottili.

L'eternità propria del pezzo risiede nel paralume con linee morbide, che supportato da una maniglia, genera un punto di tensione nella parte superiore.

Napa fornisce un'illuminazione pratica e funzionale in grado di armonizzare qualsiasi spazio, da una stanza a un ufficio o spazio commerciale, potendo essere utilizzato da solo o nell'insieme.

Informazioni tecniche pag. 33

(FR) D'inspiration scandinave, Napa a une structure aux formes simples et subtiles.

L'intemporalité de la pièce réside dans l'abat-jour aux lignes douces, qui, soutenu par une poignée, génère un point de tension au sommet.

Napa offre un éclairage pratique et fonctionnel capable d'harmoniser n'importe quelle pièce, que cela soit une chambre, un bureau ou un local commercial, en l'installant seul, ou même en éléments composés.

Information technique p. 33





# Noway

Francesc Vilaró



<sup>(IT)</sup> La dematerializzazione e il trasferimento della massima importanza alla luce, sono due degli obiettivi alla base della concettualizzazione e del design di Noway.

Di conseguenza, un apparecchio con un sorprendente effetto di assenza della gravità e della leggerezza che riesce a offrire un elevato comfort visivo, con la minima materia.

Questa collezione presenta diverse proposte, dalle versioni più pure a quelle più complesse, giocando con effetti di luce e offrendo una maggiore presenza visiva.

**Informazioni tecniche pag. 40**

<sup>(FR)</sup> Les deux principaux objectifs cachés derrière la conception de Noway, sont la dématérialisation du produit et, faire de la lumière, la plus grande protagoniste.

En conséquence, un luminaire d'effets surprenants d'apesanteur et de légèreté, qui parvient à offrir un confort visuel élevé avec un minimum de matériel.

Cette collection présente différents modèles, des versions les plus pures aux versions les plus complexes, jouant avec les effets de la lumière et offrant une présence plus visuelle.

**Information technique p. 40**











# Low Voltage



(IT) Track 48 è un sistema versatile, basato sulla combinazione di un profilo magnetico, alimentato a 48V, compatibile con varie soluzioni: proiettori, sospensioni e soluzioni lineari. Può essere installato verticalmente ed orizzontalmente, offrendo una versione ad incasso, da superficie e sospesa.

Track 48 offre al progettista una grande libertà, permettendo di illuminare spazi versatili, di regolare e spostare i punti luce con il fine di adattarsi alle mutevoli esigenze di illuminazione.

(FR) Le Track 48 est un système polyvalent basé sur la combinaison d'un profil magnétique, alimenté en 48V, compatible avec différentes options : projecteurs, suspensions et linéaires. Il peut être installé verticalement ou horizontalement, et existe en version encastrée, en surface ou suspendue.

Le Track 48 offre au designer une grande liberté, lui permettant d'éclairer des espaces polyvalents, d'ajuster et de déplacer des points lumineux pour s'adapter aux exigences changeantes de l'éclairage.





# Kiva Low Voltage



OPTI LENS CRI 90 EASY L80 B20 50000h

(IT)

- Design pulito ed ultra compatto.
- Integrazione con binari 48V.
- Eccellente controllo ottico.
- Disponibile nella versione DALI.
- Disponibile nelle finiture Essence.

Informazioni tecniche pag. 42

(FR)

- Conception pure et ultra compacte.
- Intégration avec rails 48V.
- Excellent contrôle optique.
- Disponible en version DALI.

Disponible en finitions Essence.

Information technique p. 42

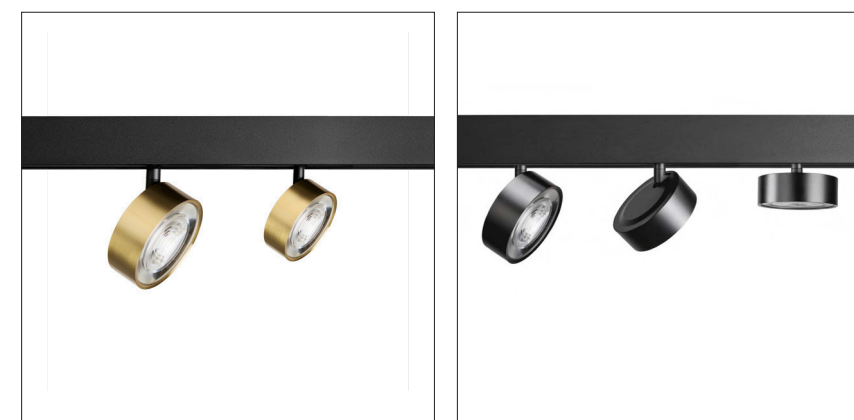



# Atom Low Voltage



(IT)

- Sistema magnetico e regolabile.
- Miniaturizzazione del proiettore per un'illuminazione integrata nello spazio.
- Ampia gamma di accessori.
- CRI 90.

Informazioni tecniche pag. 41

(FR)

- Système magnétique et réglable.
- Miniaturisation du projecteur pour fusionner l'éclairage avec l'espace.
- Vaste gamme d'accessoires.
- CRI 90.

Information technique p. 41

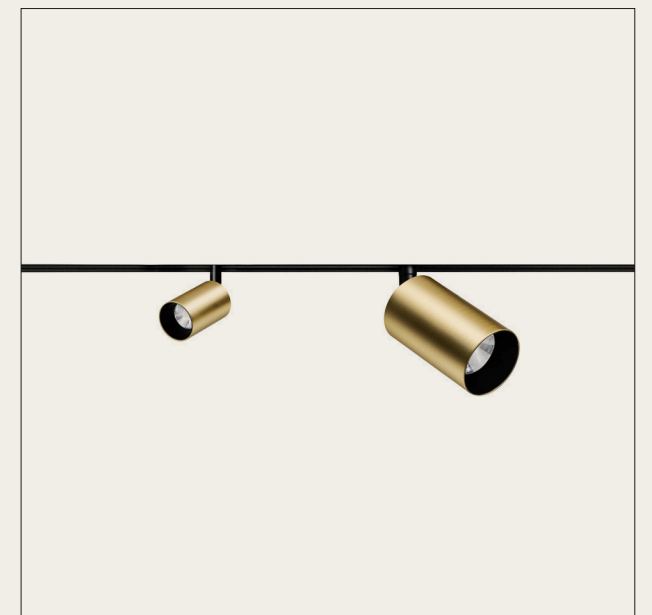



# Vela Low Voltage



(IT)

- Sospensione magnetica e regolabile.
- Integrazione con binari 48V.
- Disponibile nella versione DALI.
- Disponibile nelle finiture Essence.

Informazioni tecniche pag. 39

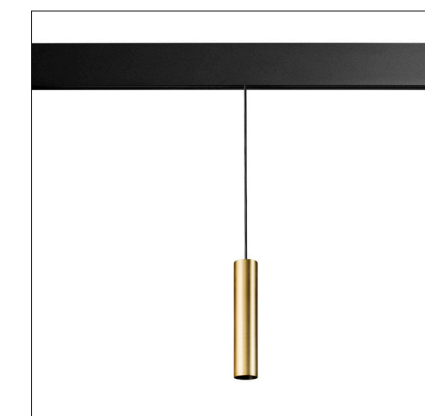

(FR)

- Suspension magnétique et réglable.
- Intégration avec rails 48V.
- Disponible en version DALI.
- Disponible en finitions Essence.

Information technique p. 39



# Track Low Voltage

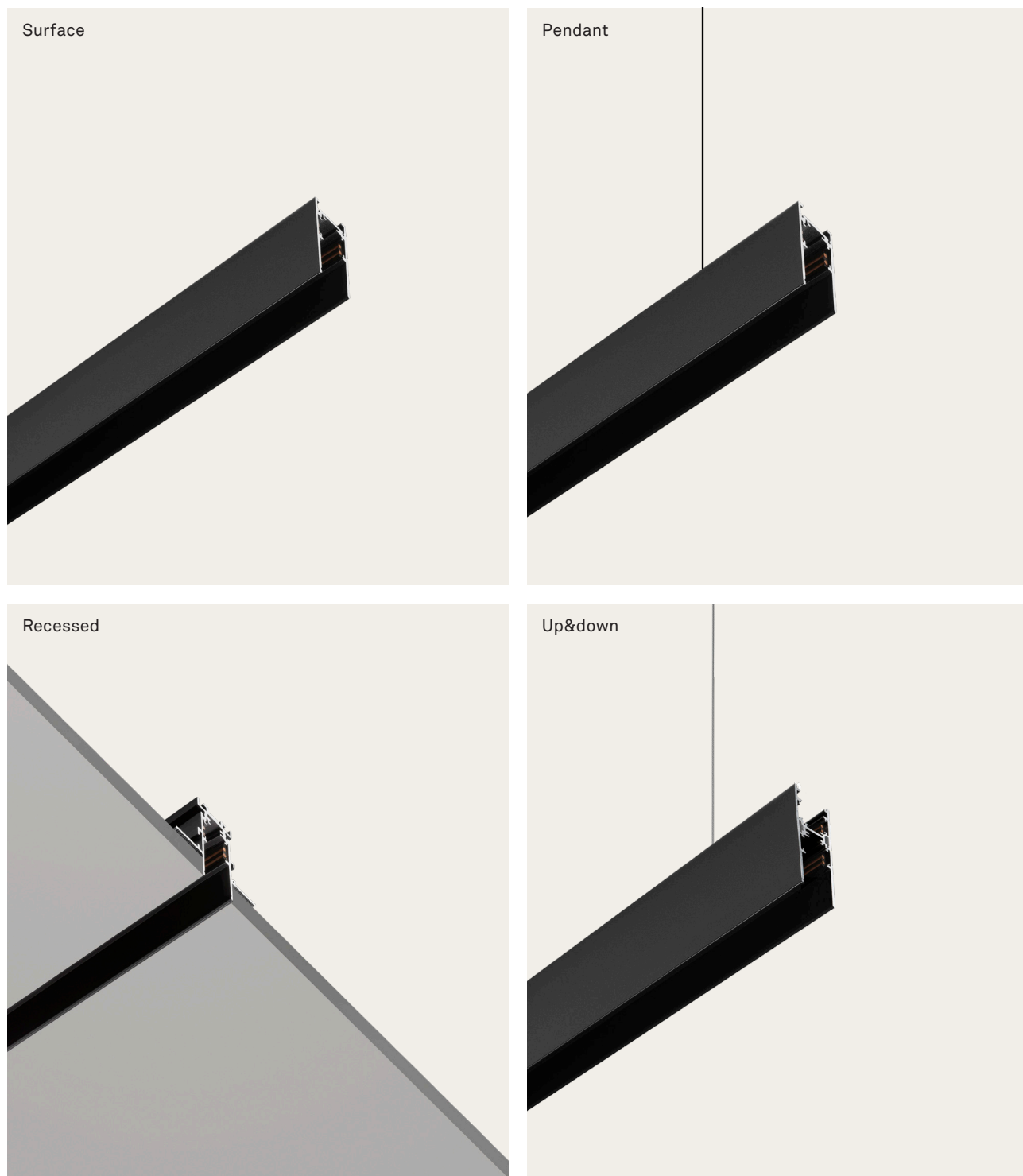

# Atom surface



OPTI  
LENS

CRI  
90

L80 B20  
50000h

(IT)

- Versatile e adattabile alle esigenze di qualsiasi progetto.
- Installazione del proiettore in superficie e in-out.
- Ampia gamma di accessori.
- CRI 90.

Informazioni tecniche pag. 44

(FR)

- Polyvalent et adaptable aux besoins de tout projet.
- Installation du projecteur en surface ou in-out.
- Vaste gamme d'accessoires.
- CRI 90.

Information technique p. 44



# Atom Hide



OPTI LENS CRI 90 EASY L90 B20 50000h

(IT)

- Versatile e adattabile alle esigenze di qualsiasi progetto.
- Installazione del proiettore in superficie e in-out.
- Ampia gamma di accessori.
- CRI 90.

Informazioni tecniche pag. 43

(FR)

- Polyvalent et adaptable aux besoins de tout projet.
- Installation du projecteur en surface ou in-out.
- Vaste gamme d'accessoires.
- CRI 90.

Information technique p. 43





# Napa N

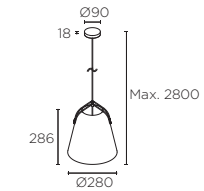

**E27** Hal - Fluo - Led

**W**

23 max. **00-7993** - 05-05 05-DN DN-DN EM-EM

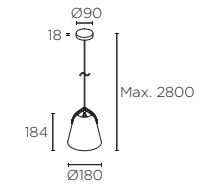

**E27** Hal - Fluo - Led

**W**

23 max. **00-7992** - 05-05 05-DN DN-DN EM-EM

Schede tecnica / Fiches techniques



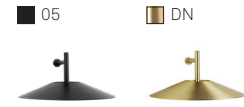

BODY MAT ST DIF MAT ACR 4 50000h L80 B20 3 MacAdam

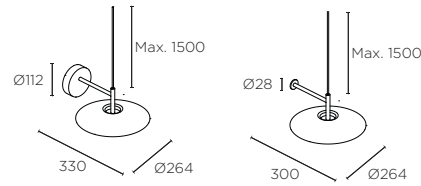

LED SAMSUNG

K	CRI	W	Real lm	05-7742	05-05	DN-DN
2700	90	14,9	553			

100-277VAC 50-60Hz

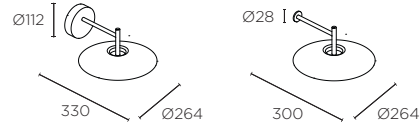
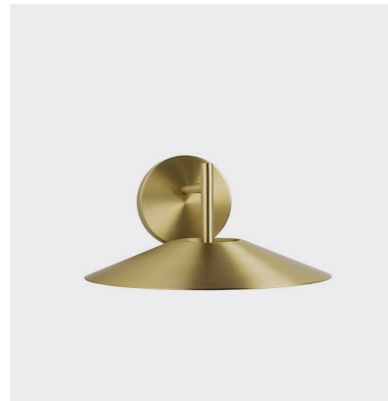

LED SAMSUNG

K	CRI	W	Real lm	05-7742	05-05	DN-DN
2700	90	14,9	553			

100-277VAC 50-60Hz

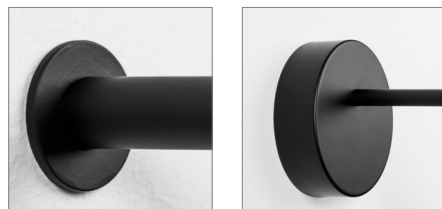

Doppia installazione: ad incasso/in superficie  
Double installation: encastré / en surface



BODY MAT AL 27 50000h L80 B20 3 MacAdam 180° 90°

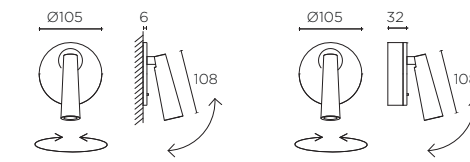
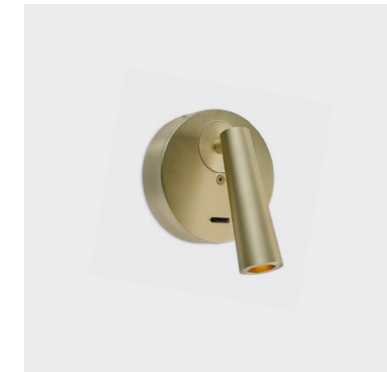

LED CREE

K	CRI	W	Real lm	25°	05-6421	14-14	81-81	Z5-Z5	DN-DN
2700	80	2,2	137						

100-240V 50-60Hz

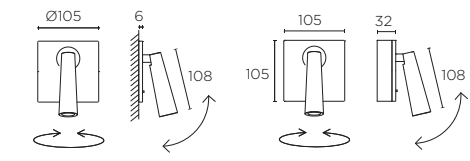
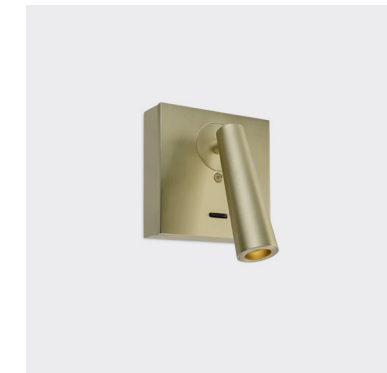

LED CREE

K	CRI	W	Real lm	25°	05-6420	14-14	81-81	Z5-Z5	DN-DN
2700	80	2,2	137						

100-240V 50-60Hz

Doppia installazione: ad incasso/in superficie  
Double installation: encastré / en surface



## Gamma Mix & Match

□ 14-14   ■ Z5-Z5   ■ 81-81   ■ DN-DN



**32 combinazioni possibili - alcuni esempi:**  
32 combinaisons possibles - quelques exemples:

BODY MAT AL   ®   ⓘ   27   50000h L80 B20   3 MacAdam   ⏻   ⓘ   180°   ↻ 90°



05-6421-Z5-DN



05-6421-81-Z5



05-6420-14-Z5



05-6420-Z5-14



05-6421-14-81



05-6421-DN-Z5



05-6420-Z5-81



05-6420-14-DN

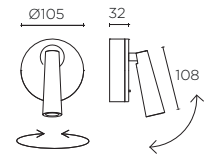
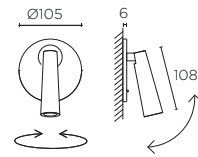

Mix & Match

LED CREE		K		CRI	W	Real lm	▲	25°	05-6421	-	14	14
											81	81
											Z5	Z5
											DN	DN

100-240V 50-60Hz

## Gamma Mini

□ 14   ■ Z5   ■ 81   ■ DN



BODY MAT AL   ®   ⓘ   50000h L80 B20   3 MacAdam   ⏻   ⓘ   180°   ↻ 90°



05-6428-Z5-DN



05-6428-Z5-Z5



05-6428-DN-DN



05-6428-14-14



05-6428-81-81



05-6428-DN-Z5



05-6428-Z5-81



05-6428-14-DN

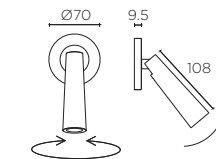

Mix & Match

LED CREE		K		CRI	W	Real lm	▲	25°	05-6428	-	14	14
											81	81
											Z5	Z5
											DN	DN

Ø40  
100-240V 50-60Hz



Doppia installazione: ad incasso/in superficie  
Double installation: encastré / en surface



## Gamma

□ 14 ■ Z5 ■ 81 ■ DN



BODY MAT ST/AL DIF MAT PC 2 50000h L80 B20 2 MacAdam 355° 90°



LED CREE		K	CRI	W	Real lm	▲	□	■	■	■
2700	80	3,2	319	60°	10-6420	-	14-14	81-81	DN-DN	Z5-Z5

100-240V 50-60Hz

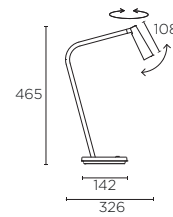

## Gamma

■ Z5-Z5 ■ DN-DN



BODY MAT ST/AL DIF MAT PC 355° 90°



LED CREE		K	CRI	W	Real lm	▲	■	■
2700	80	3,2	319	60°	25-6420	-	Z5-Z5	DN-DN

100-240V 50-60Hz

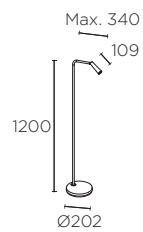

## H

■ 05 ■ DN ■ 05 ■ DN



BODY MAT ST DIF MAT ACR 50000h L80 B20 3 MacAdam

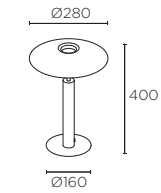

LED SAMSUNG		K	CRI	W	Real lm	■	■
2700	90	14,9	553	10-7742	-	05-05	DN-DN

220-240VAC 50-60Hz

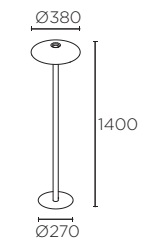

LED SAMSUNG		K	CRI	W	Real lm	■	■
2700	90	14,9	553	25-7742	-	05-05	DN-DN

220-240VAC 50-60Hz

## Vela low voltage

■ 60 ■ 81 ■ DN



BODY MAT AL 50 50000h L80 B20 2 MacAdam

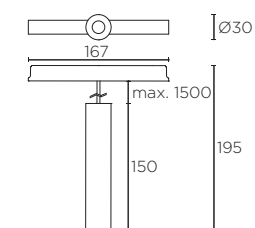
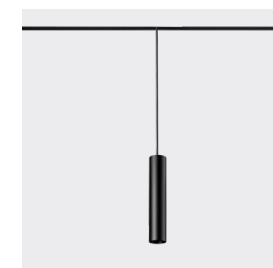

LED CREE		K	CRI	W	Real lm	▲	■	■	■
2700	90	3,1	269	24°	00-7341	-	60	81	00
3000	90	3,1	269	24°	00-7342	-	DN	DN	DA

ON-OFF  
DALI  
48VDC P.95



## Noway N

DN 05



BODY MAT ST 50000h L80 B20 3 MacAdam

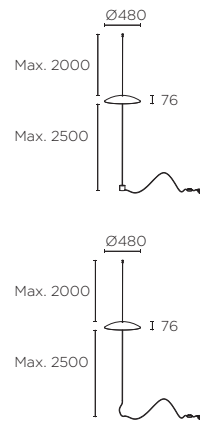

LED EDISON						
K	CRI	W	Real lm			
3000	80	18	791	00-7980	- DN-DN - 05-05	
220-240VAC 50-60Hz						

LED EDISON						
K	CRI	W	Real lm			
3000	80	18	791	00-7981	- DN-05 - 05-05	
220-240VAC 50-60Hz						

## Noway N

DN 05



BODY MAT ST 50000h L80 B20 3 MacAdam

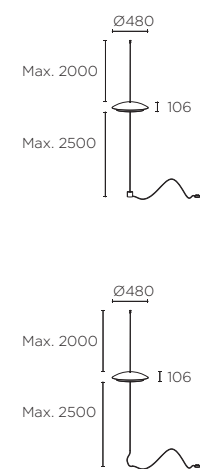

LED EDISON						
K	CRI	W	Real lm			
3000	80	18	495	00-7977	- DN-DN - 05-05	
220-240VAC 50-60Hz						

LED EDISON						
K	CRI	W	Real lm			
3000	80	18	495	00-7979	- DN-05 - 05-05	
220-240VAC 50-60Hz						

## Atom low voltage 29

14 60 81 DN



BODY MAT AL IP20 100 50000h L80 B20 2 MacAdam LOW FLICKER 90° 360°

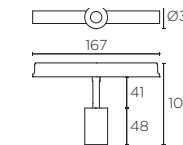
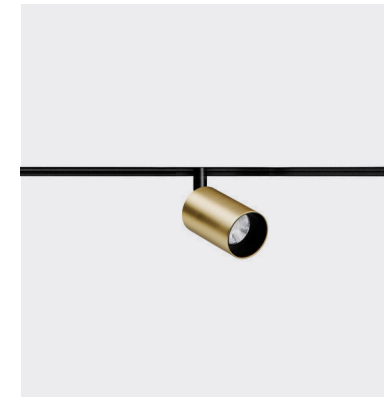

LED CREE						
K	CRI	W	Real lm			
2700	90	3,1	269	24°	35-7285	14 60 - 00
3000	90	3,1	269	24°	35-7286	81 - 00 DA
48VDC P.232						

## Atom low voltage 52

BODY MAT AL IP20 50000h L80 B20 2 MacAdam LOW FLICKER 90° 360°

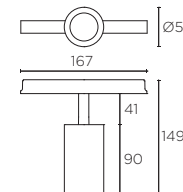
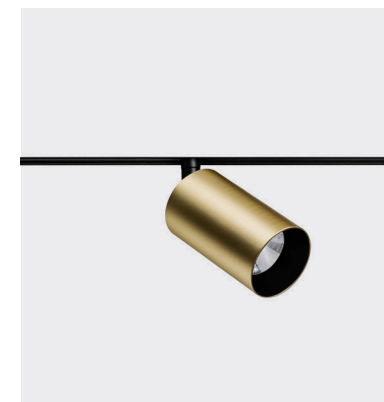

LED CREE						
K	CRI	W	Real lm			
2700	90	12,1	853	24°	35-7279	14 60 - 00
			928	33°	35-7280	81 - 00 DA
			778	43°	35-7281	DN
3000	90	12,1	853	24°	35-7282	14 60 - 00
			928	33°	35-7283	81 - 00 DA
			778	43°	35-7284	DN
48VDC P.232						

### Non incluso / Non inclus

	50 Comfort visivo Confort visuel	71-6276	- 60 - 00
	Visiera Visière	71-6277	- 60 - 00
	Cerchio frontale Cercle avant	71-6436	- 14 - 00 23

	100 5 x Diffusore ellittico 5 x Diffuseur elliptique	71-6274	- 00 - 00
	5 x Pannello d'ape 5 x Panneau d'abeille	71-6273	- 60 - 00
	5 x Attenuatore dell'alone 5 x Atténuateur de halo	71-6275	- 00 - 00



## Kiva low voltage 75 N

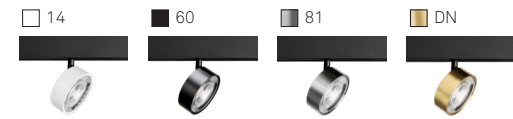

BODY MAT AL 50 50000h L80 B20 2 MacAdam <16 UGR 90° 360°

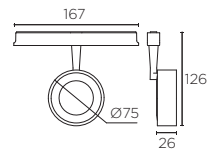

LED CREE		K	CRI	W	Real lm	▲		
2700	90	6,4	458	24°	<b>35-8035</b>	14	00	DA
						60		
3000	90	6,4	530	24°	<b>35-8036</b>	81	00	DA
						DN		

00 ON-OFF  
DA DALI  
 48VDC P.232

## Kiva low voltage 95 N

BODY MAT AL 50 50000h L80 B20 2 MacAdam <16 UGR 90° 360°

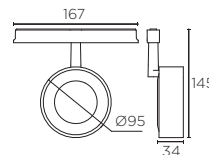

LED CREE		K	CRI	W	Real lm	▲		
2700	90	12	1172	24°	<b>35-8037</b>	14	00	DA
						60		
3000	90	12	1320	24°	<b>35-8038</b>	81	00	DA
						DN		

00 ON-OFF  
DA DALI  
 48VDC P.232

## Atom Hide Small

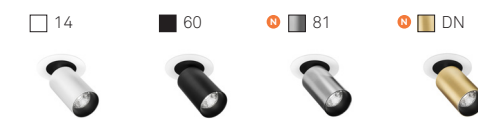

BODY MAT AL / PC 50000h L80 B20 2 MacAdam 90° 320°

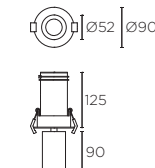
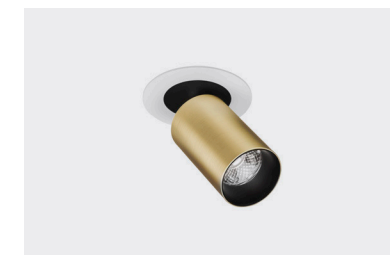

LED CREE		K	CRI	W	Real lm	mA	▲		
2700	90	12,1	853	350 max.	24°	<b>90-7273</b>	14	00	
			928	350 max.	33°	<b>90-7274</b>	60		
			778	350 max.	43°	<b>90-7275</b>	81	DN	
3000	90	12,1	853	350 max.	24°	<b>90-7276</b>	14	00	
			928	350 max.	33°	<b>90-7277</b>	60		
			778	350 max.	43°	<b>90-7278</b>	81	DN	

Ø80 0-20mm  
220-240V 50-60Hz

1x1  
ON-OFF 71-6652  
PHASE CUT 71-5272  
0/1-10V 71-7710  
0/1-10V/  
PUSH/DALI 71-6192  
 P.306

### Non incluso / Non inclus

- 50 Comfort visivo Confort visuel **71-6276 - 60 - 00**
- 50 Visiera Visière **71-6277 - 60 - 00**
- 50 Cerchio frontale Cercle avant **71-6436 - 14 - 23 - 00**

- 100 5 x Diffusore ellittico 5 x Diffuseur elliptique **71-6274 - 00 - 00**
- 100 5 x Pannello d'ape 5 x Panneau d'abeille **71-6273 - 60 - 00**
- 100 5 x Attenuatore dell'alone 5 x Atténuateur de halo **71-6275 - 00 - 00**



# Atom Surface



BODY MAT AL DIF MAT PC 50000h L80 B20 3 MacAdam 90° 320°

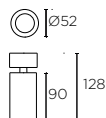



## LED VOSSLOH

K	CRI	W	Real lm	Beam	Code	Option
2700	90	7,5	331	24°	<b>15-6482</b>	14
			319	33°	<b>15-6483</b>	60 - 81 - MS
			259	43°	<b>15-6484</b>	DN
3000	90	7,5	331	24°	<b>15-6485</b>	14
			319	33°	<b>15-6486</b>	60 - 81 - MS ML
			259	43°	<b>15-6487</b>	DN

MS MAINS L,C 220-240V 50-60Hz  
ML MAINS L,C 110V 50-60Hz

## Non incluso / Non inclus

 50	Comfort visivo Confort visuel	<b>71-6276</b>	- 60 - 00
	Visiera Visière	<b>71-6277</b>	- 60 - 00
	Cerchio frontale Cercle avant	<b>71-6436</b>	- 14 23 - 00

 100	5 x Diffusore ellittico 5 x Diffuseur elliptique	<b>71-6274</b>	- 00 - 00
	5 x Pannello d'ape 5 x Panneau d'abeille	<b>71-6273</b>	- 60 - 00
	5 x Attenuatore dell'alone 5 x Atténuateur de halo	<b>71-6275</b>	- 00 - 00



**LEDS C4 S.A**

Afores s/n 25750 Torà  
Lleida, Spain  
(+34) 973 468 100

[leds-c4.com](http://leds-c4.com)