

D O L C E V I T A C O L L E C T I O N



Formerin

*luxurious style interior*

Formerin, azienda italiana nata negli anni '60, specializzata nella produzione di sedute per casa e collettività, si configura come un player di riferimento in entrambi questi settori. Nel corso degli ultimi anni l'azienda ha consolidato il brand in Italia e all'estero con un'offerta multiprodotto che rende l'azienda una realtà compiutamente integrata, che si posiziona a pieno titolo tanto nel settore delle sedute per la casa quanto in quello per la collettività. Il successo dell'azienda passa inoltre attraverso la cultura della soddisfazione del cliente. Un'attenzione continua e pienamente riconosciuta, che oltre alla fornitura di prodotti di altissima qualità, si manifesta in un'assistenza completa, dalla definizione del progetto alla sua realizzazione. I buoni risultati dell'azienda nel panorama internazionale trovano il proprio fondamento anche nella puntuale attenzione ad ogni particolare del prodotto. L'industrializzazione del prodotto si accompagna infatti di pari passo alla cura artigianale dei materiali, al fine di fornire delle sedute perfette nei più piccoli dettagli. Personale altamente specializzato controlla che ogni fase del ciclo produttivo risponda a quei requisiti qualitativi e di pregio da sempre riconosciuti all'azienda. Un patrimonio di conoscenza e tradizione che, unito alla passione per l'eccellenza, garantisce un prodotto altamente curato.

Formerin is an Italian company that was founded in the 1960s. It specializes in the production of seating for homes and public spaces and is a leading player in both of these fields. In recent years, the company has developed a multi-product range that has consolidated its brand in Italy and the international market. It is now a fully integrated business and a well-established part of both the home seating and public seating sectors. One of the keys to the company's success is its dedication to customer satisfaction. Its fully acknowledged, ongoing devotion to this aspect is made apparent not only by its extremely high-quality products but also by comprehensive assistance, from the definition of designs to their execution. Meticulous attention to detail in every facet of the products is another of the cornerstones of the company's impressive results on the international stage. Industrial manufacturing of products goes hand in hand with artisanal care for materials, thus ensuring that the seats are perfect down to the last detail. Highly specialized staff monitor all of the stages in the production cycle to make sure that they meet the superior quality requirements for which the company has always been renowned. Our wealth of know-how and tradition comes together with our quest for excellence in our painstakingly made products.

# Formerin: una storia italiana

Abbiamo creato una serie d'imbottiti e complementi dal deciso tratto progettuale declinati in una vasta gamma di forme e dimensioni facili da accostare, seguendo l'istinto e la passione, più che la logica o la moda, per creare in ogni ambiente il proprio stile. Una collezione in cui l'equilibrio fra classico e moderno si traduce in un modo d'arredare personale e cosmopolita. Perché il fascino di una casa nasce da un insieme di elementi, suggestioni e riferimenti che la rendono elegante e funzionale, la propria casa.

Soft forms are complemented by sophisticated finishes in a new upholstered collection with distinctive design features and a wide range of shapes and sizes. We have created a selection of upholstered items and accessories that are easy for everyone to match together, following their inclinations and instincts rather than logic or fashion to add their own, individual style to every setting. It is a collection in which the balance between classic and modern takes shape in a personal, cosmopolitan approach to furnishing. After all, the appeal of every dwelling is based on the blend of elegant, practical features, charms and allusions that make it into a home.

## Dolcevita collection

Formerin makes the most of its appetite for experimentation with its constant drive for new projects and success, safe in the knowledge that its qualities - especially those of an ethical and moral nature - will shine through. It takes particular care over the design and manufacturing of its products, scrupulously studying the many aspects behind high-quality upholstered items. Dolcevita is the latest collection to embody the company's aim of leveraging both craft skills and industrial experimentation with innovative solutions. The technical and functional qualities of the materials in our products are often invisible, but they can help to establish the style of a home, with a wealth of choices and balanced taste. There are numerous colours, finishes and possibilities for use. It is a complex, flexible and versatile range containing a selection of distinctive elements, many of which are modular. They can be used to customize any interior design scheme and cater to specific taste and space requirements. The items combine aesthetic rigour and functional exactitude, structural quality and creativity, market solidity and innovation.

Formerin, forte della sua voglia di sperimentare, sicura delle sue qualità, soprattutto etiche e morali, è proiettata verso sempre nuovi progetti e successi. Ponendo una particolare cura nella progettazione e realizzazione dei propri prodotti, studia i molteplici aspetti che caratterizzano un imbottito di qualità. Dolcevita è l'ultima collezione che racconta una storia aziendale tesa a valorizzare contemporaneamente la capacità artigianale e la sperimentazione industriale di soluzioni innovative. Qualità nascoste sono le qualità tecniche e funzionali dei materiali presenti nei nostri prodotti, spesso invisibili, che offrono la possibilità di definire, con ricchezza di scelta e con equilibrio di gusto, lo stile della propria casa. Molteplici i colori e le finiture, così come le destinazioni d'uso; un programma complesso, flessibile e versatile, composto da elementi funzionali differenziati e spesso modulari, attraverso i quali è possibile personalizzare ogni intervento progettuale adattandolo a specifiche esigenze sia di gusto che di spazio. Oggetti che uniscono rigore estetico e rigore funzionale, creatività e qualità strutturali, innovazione e concretezza di mercato. Un'ampiezza di proposte divenuta oggi consistente, per coprire esigenze e fasce di gusto diverse.



## Mastroianni

Dall'immagine di eleganza, equilibrio e pulizia, il modello si contraddistingue per un design decisamente innovativo, coadiuvato da un grande comfort. Grande flessibilità progettuale e soluzioni tecniche d'avanguardia: Mastroianni si sviluppa in un gioco di volumi tra struttura, braccioli e imbottiture, tutti amalgamati in linee pulite e rigorose. Un progetto coerente ed equilibrato realizzato con ottimi materiali e l'attenta cura dei particolari.

The model has an elegant, balanced and clean-cut image and it pairs highly innovative design with great comfort. Immensely flexible design and cutting-edge technical solutions: The volumes of Mastroianni's structure, armrests and upholstery playfully interact within the sharp, crisp lines. The poised, finely balanced design has been executed with outstanding materials and great attention to detail.

## Mastroianni

La concretezza delle forme ben rispecchia la solidità dei contenuti di questo progetto che ridisegna, con creativa semplicità e razionale modularità, gli spazi del living, conferendo agli ambienti un valore aggiunto di modernità e al contempo di eleganza. Frutto di un design minimalista ma ricco di stile, è un modello nobilitato da un forte contenuto progettuale oltre che dalla grande qualità dei materiali utilizzati.

The substantial shapes marvellously reflect the solidity of the content, which redesigns living spaces with creative simplicity and rational modularity, adding a sense of modernity and elegance. This model has a minimal but highly stylish design that is packed with character and wonderfully complemented by the exceptional quality of the materials.





Mastroianni



## Mastroianni

Grande versatilità e razionalità progettuale in forme semplici, squadrate, quasi basiche. Seduta ideale per ambienti in cui eleganza e rigore formale vengono messi in primo piano, Mastroianni è studiato con la massima cura in ogni minimo dettaglio proprio per chi desidera circondarsi di oggetti d'arredo di design, oltreché confortevoli.

Supremely versatile and rational design in simple, almost basic block forms. Mastroianni is an ideal seating solution for places where elegance and sharp looks are in centre stage. The greatest possible care has been taken over every single detail, making it perfect for those who love to be surrounded by comfortable yet stylish designer furniture.





Diversi elementi per una grande potenzialità compositiva; Mastroianni dà forma all'immaginazione consentendo di creare spazi personalizzabili in una svariata fantasia di forme, colori e materiali. Il modello non vuole essere soltanto un posto a sedere, ma emergere con un'identità sua propria.

An array of elements offering great compositional potential. Mastroianni lets the imagination take concrete form by creating customized settings featuring a huge range of shapes, colours and materials. As well as providing seating, the model is designed to have its own, prominent identity.



Mastroianni





Mastroianni



Coffee table, work table sono oggetti esteticamente di grande pregio e soprattutto funzionali, in grado di assicurare una forte caratterizzazione dello spazio. Sono progettati per essere un utile complemento ai divani della nuova collezione, oggetti neutrali facilmente accostabili a diversi generi di stile e design.

Coffee tables and work tables are aesthetically appealing and highly practical items that can really make an impact on their surroundings. They are designed to serve as practical accessories that can complement the sofas in the new collection. As neutral pieces, they can easily be matched with different styles and designs.





# Mastroianni

Mastroianni unisce gusto ed eleganza a una componibilità fatta di leggerezza e duttilità, arricchita da un'ottima ergonomia in grado di assicurare il massimo comfort. La sottile piattaforma rivestita su cui poggiano i cuscini è l'elemento fortemente distintivo del modello che gioca nel contrasto tra spigolosità e morbidezze ideate da un ricercato design.

Mastroianni combines taste and elegance with light, flexible modularity, which is enhanced by exceptional ergonomics for maximum comfort. The cushions lie on a slender upholstered platform, which is the distinguishing feature of the piece. The sophisticated design playfully contrasts softness and sharp edges.





Mastroianni

## Fellini

E' un modello dalla forte personalità, fatto di linee pulite ed essenziali per un risultato di importante valore estetico. Di grande contemporaneità, è caratterizzato da morbide imbottiture contenute in forme decisamente squadrate, addolcite da dettagli che spezzano le linee e impreziosiscono la razionale semplicità del bracciolo. Vari accessori contribuiscono a rendere lo spazio del living più accogliente e vivibile.

This is a model with a strong personality whose clean-cut, simple lines have huge aesthetic appeal. It is highly contemporary, with soft padding in sharp, blocky forms that are mellowed by details breaking up the lines and embellishing the rational simplicity of the armrests. A selection of accessories helps to make the living space more inviting and welcoming.





## Fellini

Design e comfort si integrano felicemente in uninsieme in cui la forma è sempre in totale armonia con la funzione. Cura attenta dei dettagli, preziose lavorazioni e ricerca di particolari finiture sono alla base di questo progetto di alta qualità industriale ma con i caratteri della lavorazione artigianale. Il decoro in metallo che caratterizza il bracciolo aumenta il pregio e la particolarità del modello.

Design and comfort are fused splendidly in an ensemble whose form is always in perfect harmony with its function. Attention to detail, exquisite workmanship and a search for distinctive finishes are at the heart of this design, whose superb industrial quality comes with craft-like features. The metal decorations on the armrests add to the singular allure of the piece.









Fellini





Tavoli, tavolini, servetti non sono mai oggetti banali ma arricchiscono il divano e lo rendono unico e personalizzabile a seconda del proprio gusto e delle proprie esigenze. Prestigio estetico, stile, eleganza, cura manuale del particolare e delle finiture: anche negli accessori si intuisce la qualità intrinseca dei nostri prodotti.

There is always something interesting about tables, coffee tables and side tables. They can add a special, unique touch to sofas and customize them to suit individual tastes and needs. Aesthetic eminence, style, elegance and hands-on attention to detail and finishing: intrinsic quality is evident in all of our products and the accessories are no exception.



Fellini

# Michelangelo

Design by Gianluca Ferullo

Modello prestigioso e dalla grande personalità, è un classico dalla linea contemporanea in cui design e funzionalità si fondono assieme in un equilibrio armonioso. Raffinato il design, curati i dettagli, selezionati i materiali: la preziosità dell'acciaio nobilita il modello conferendogli grande eleganza e raffinatezza. Un gusto classico interpretato in chiave attuale con grande coerenza per diverse interpretazioni.

This prestigious piece with a strong personality is a classic with a contemporary look that harmoniously balances design and functionality. The design features meticulous detailing and select materials such as sublime steel, which adds an elegant, refined touch. A highly consistent fresh take on classic tastes that opens up numerous options.







Formérin 40

## Michelangelo

Linee semplici e materiali importanti: un elemento contenitore chiuso da ricercate ante curvate in metallo verniciato fa di Michelangelo una libreria composita e aggregabile in grado di arredare con eleganza anche pareti di importanti dimensioni. La luminosità del tek e la brillantezza dell'acciaio creano un contrasto di forte impatto visivo.

Simple lines and substantial materials: a storage unit with sophisticated curved and coated metal doors makes Michelangelo a versatile bookcase that can be combined with other items or stylishly adorn sizeable walls. The radiant teak and bright steel create a visually stunning contrast.



Formérin 41

## Michelangelo

Leggerezza e ricercata eleganza sono le caratteristiche della libreria Michelangelo, realizzata con una struttura in acciaio e ripiani in finitura tek lucido. È frutto di un design che offre linee attuali per un insieme che unisce qualità di lavorazione a materiali pregiati.

Lightness and refined elegance are the core features of the Michelangelo bookcase, which has a steel structure and shelves with a polished teak finish. The contemporary lines in the design blend high-quality workmanship with superior materials.





## Anita

Protagonista di ambienti importanti, Anita è un modello che con le sue linee classiche ma contemporanee e raffinate contribuisce a creare un'atmosfera di eleganza e comfort. È la seduta ideale per un ambiente in cui l'attenzione per lo stile e il rigore formale diventano importanti.

Anita grabs the spotlight in high-profile settings. Its classic but contemporary and refined lines help to create an elegant, comfortable atmosphere. It is the ideal seating solution for places where style and formal exactitude are crucial.

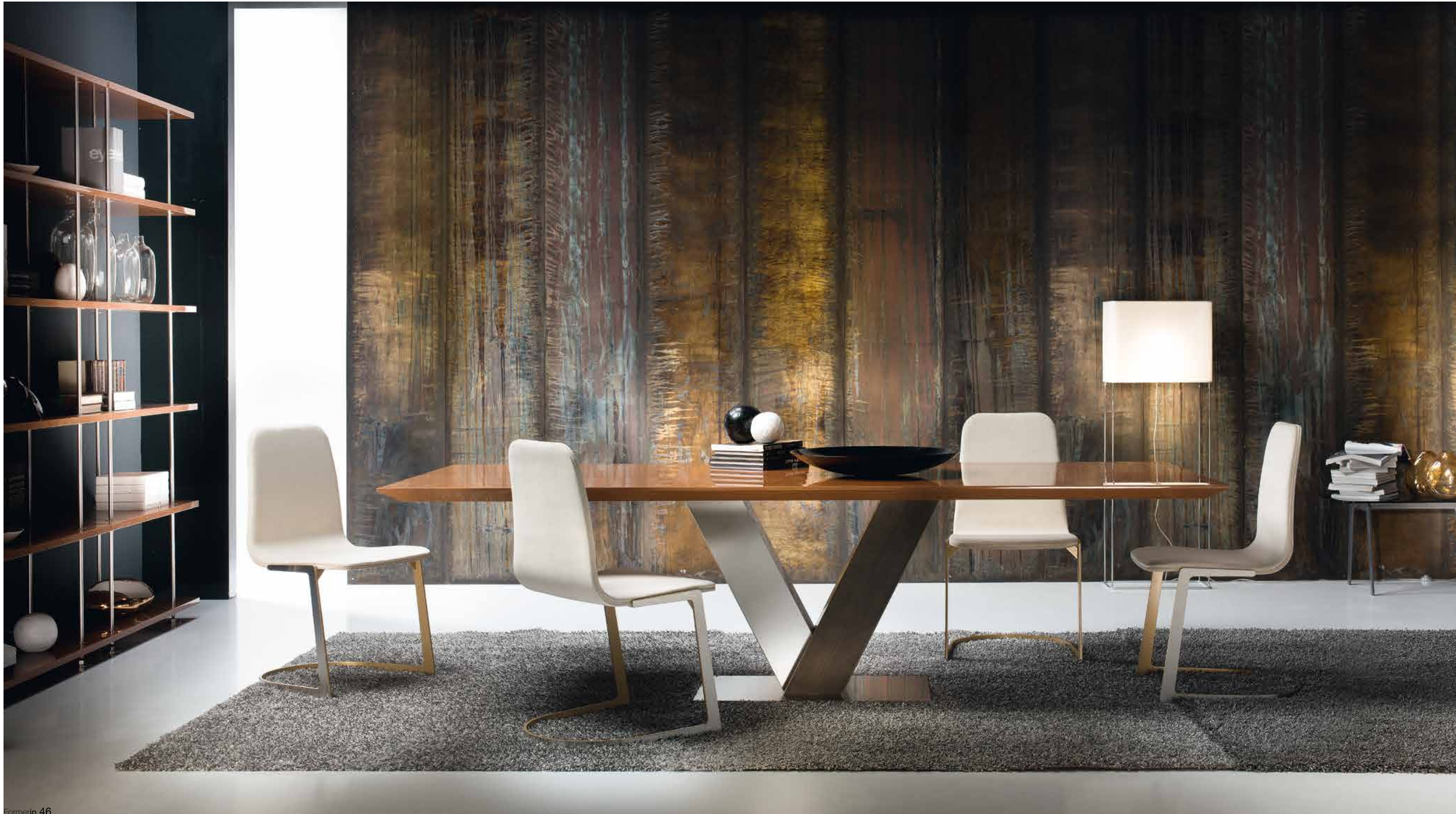

## Totò

Design by Luca Roccadadria - Centro Stile Formerin

Poche linee per un progetto di grande pulizia formale: Totò è un tavolo con un'importante base in acciaio che sostiene l'elegante piano in tek verniciato lucido, abbinato perfettamente ai ripiani della libreria.

Con Totò si sperimenta un minimalismo che ricerca il confronto tra essenzialità e gusto della materia e degli spessori.

La sedia Anita rafforza l'immagine di una raffinata ambientazione.

A few simple lines establish the crisp shape of the design. Totò is a table with a substantial steel base under an elegant gloss varnished teak top, which perfectly matches the shelves in the bookcase.

Totò's minimalism juxtaposes essentiality and taste in materials and volumes.

The Anita chair reinforces the image of refined surroundings.





## Visconti

Semplicità e rigore delle forme, pulite e misurate nelle proporzioni, per un'eleganza pulita ed essenziale. Morbide imbottiture creano un soffice guscio di comfort che poggia su eleganti e leggeri piedini in metallo. Una scelta elegante e dinamica in pieno stile contemporaneo, dove design e praticità d'uso trovano un equilibrato punto d'incontro offrendo la massima flessibilità per creare diverse ambientazioni sia di stile e funzionalità che di dimensioni e forma.

Its clean-cut, understated elegance is built on simple, stringent shapes and crisp, measured proportions. Soft padding creates a cosy shell of comfort resting on light, elegant metal feet. It takes an elegant, dynamic and highly contemporary approach, with finely poised style and practicality for maximum flexibility. This provides broad scope for settings with different looks, functions, sizes and shapes.



Un forte impatto estetico mixato a grande comfort: Visconti risponde concretamente ai principi di design, ergonomia, flessibilità e personalizzazione dello spazio con grande eleganza e con la semplicità delle cose belle e senza tempo. Molto accurata la ricerca del dettaglio in questo modello dal design moderno e attuale con sottili richiami ad elementi di classicità.

A combination of powerful visual impact and great comfort: Visconti tangibly espouses the principles of design, ergonomics, flexibility and customization of space with great elegance and the simplicity of timeless beauty. Outstanding attention to detail is shown in this modern, cutting-edge design with subtle nods to classic features.

Visconti



L'unica eccezione al rigore delle forme è data dalla particolare lavorazione del bracciolo: la lucentezza e i riflessi del vetro rendono tutto più leggero e mettono in risalto l'incastro della seduta sul bracciolo. Il particolare piede/slitta in metallo contribuisce a dare pregio e particolarità al modello.

The only exception to the austerity of the forms is the distinctive workmanship on the armrests: the reflective shine of the glass makes everything lighter and emphasizes the joint between the seat and the armrest. The design is given offbeat charm by the original feet/sled base.



Visconti



L'eleganza è fatta di dettagli: preziose mattonelle in vetro rivestono il frontale del bracciolo per donare luminosità e preziosità ad un modello già di per sé ricco di contenuti qualitativi. Grandi performances di confort sono garantite dalle morbide e sostenute imbottiture dei cuscini.

Elegance is built on details: the delightful glass tiles on the front of the armrests add ethereal radiance to a design that is already packed with superior contents. The soft, substantial cushion padding guarantees outstanding comfort.



Visconti



# Visconti plus



Oggetto sobrio e lineare, in cui una ricca semplicità è protagonista.  
Delicati decori e pregevoli dettagli danno vita ad oggetti di grande equilibrio formale, plasmati  
con suggestive forme e rifiniti con preziosi e ricercati rivestimenti.

Sober, linear items with a rich simplicity the main player.  
Delicate decorations and refined details giving life to items with formal balance, shaped  
suggestively and finished with precious, elegant covers.



Visconti plus



Fomerin 60



Fomerin 61

Visconti plus





# Manfredi

Eleganti equilibri, semplici ed essenziali nella loro eleganza per una forma originale, moderna e classica allo stesso tempo. Storia di un connubio perfetto tra toni densi di poesia e linguaggi che parlano di forme razionali e decise e insoliti accordi. I preziosi dettagli e i forti accenti del disegno sorprendono l'occhio; materiali pregiati, eleganti finiture e preziosi dettagli in un contesto di grande rigore e pulizia si stemperano nella morbidezza materica dei cuscini in piuma d'oca.

Elegant, simple balance, for an original form that is classic and modern at the same time. A tale of a perfect combination between tones bursting with poetry and languages that talk of rational, clear forms and rare accords. The peerless details and striking design are truly eye catching. Fine materials, elegant finishes and polished details in an austere ensemble are softened by fluffy goose down cushions.







## Manfredi

Accoglienza ai massimi livelli. Ricevimento e confort si integrano felicemente in un sistema in cui la forma è sempre in totale armonia con la funzione. Manfredi è il modello ideale per chi cerca un divano di grande immagine ma pretende da esso anche il massimo confort: cuscinate in piuma e una struttura solida e ben progettata assicurano un relax a 360°; il disegno ricercato ed insolito del bracciolo lo rende prezioso, molto particolare ed insolito.

Superlatively cosy. Accommodation and comfort are fused splendidly in a system whose form is always in perfect harmony with its function. Manfredi is the ideal model for those who want a sofa that can offer both stunning looks and maximum comfort. Feather cushions and a solid, well-designed structure promote all-round relaxation, while the sophisticated, offbeat design of the armrests adds a divine, unconventional and very distinctive touch.





E' un modello per qualsiasi stile d'arredo elegante, sia classico che moderno, al di fuori delle mode e quindi "senzatepo" che supera indenne la volubilità dell momento mantenendo intatta nel tempo la propria qualità di unicità. Un oggetto di design che risponde ad una ricerca di forme essenziali ma ricercate, ricche di contenuti oltre che di bellezza, e che risponde concretamente ai principi di ergonomia, funzionalità, flessibilità e personalizzazione dello spazio.,

It is a model for smart interior design schemes of all kinds, both classic and modern. It steers clear of passing fads, so it will keep its unique, timeless appeal over the years. This designer piece caters to the demand for simple but sophisticated shapes that are attractive and packed with qualities, while also tangibly embracing the principles of ergonomics, functionality, flexibility and customization of space.



Manfredi



Manfredi



Fornierin 74

Un classico dalle forme contemporanee in cui design, comfort e funzionalità si fondono assieme. Il modello si arricchisce di confortevoli imbottiture e ricercate cuciture che gli conferiscono una particolare eleganza e lo rendono protagonista dello spazio.

A classic with a contemporary look that fuses design, comfort and practicality. The comfortable padding and sophisticated stitching give the model an elegance all of its own and bring it to the fore in any setting.



Fornierin 75

Manfredi

# Manfredi

Caratterizzato dal particolare bracciolo squadrato reso però morbido da una particolare lavorazione tipo "vecchia tappezzeria", Manfredi offre ampi e morbidi spazi per una seduta confortevole e rilassante. La fascia metallica sottoseduta che caratterizza il modello si abbina perfettamente alla finitura dei piedini e alla cornice del bracciolo. Niente è lasciato al caso in questo modello in cui il dettaglio fa davvero la differenza.

The idiosyncratic blocky armrests are made soft by a special "traditional upholstery" process. Manfredi provides broad, cosy spaces for comfortable, relaxing seating. The model's trademark metal strip under the seat perfectly matches the finish on the feet and the armrest trims. Nothing is left to chance in this model, in which the details really make the difference.









## Manfredi



Poche linee ben calibrate determinano un grafismo essenziale in una forma semplice ed elegante, garantendo comunque un comfort eccezionale. Solido nella forma, importante nei contenuti, è reso esteticamente accattivante dal profilo in metallo che ne disegna i tratti essenziali; i dettagli sono infatti il punto forza del modello, ciò che ne determina lo stile e l'identità.

Just a few well-balanced lines establish simple, stylish graphic appeal while offering exceptional comfort. The solid shapes and substantial contents are given aesthetic allure by the metal profile running around the key features. The details are the cornerstone of the model and they define its style and identity.

## Manfredi basic

Un modello molto attuale che unisce un'immagine di nuovo classico ad un concetto di seduta contemporanea, ampia e spaziosa. Moderno formalmente e concettualmente, è un modello di forte impatto visivo e di grandi contenuti funzionali, ottimale per creare uno spazio a propria misura. La collezione contempla ampie e profonde sedute in piuma d'oca, complici di benessere e comfort.

An extremely modern model combines a new classical image with a contemporary concept of a well proportioned seat. Formally and conceptually modern, this is a practical model with a strong visual impact, excellent for creating a bespoke space. All the elements in the plan involve deep, comfortable seats that contribute to your wellbeing and comfort.





E' una versione più semplice del divano Manfredi, a cui viene tolta la cornice dorata. Sobrio ed elegante, il disegno di questo modello riesce a valorizzare proporzioni perfettamente equilibrate in morbidi volumi. L'accuratezza del particolare, studiato ed eseguito con grande cura, spesso determina la personalità del modello. Un elegante spazio dell'abitare fatto di forme ricercate esaltate dalla peculiarità delle lavorazioni.

It ' a simpler version of the Manfredi sofa, to which the golden frame is removed. The design of this model is sober and elegant and adds value to perfectly balanced proportions with soft volumes. Painsstaking details, designed and carried out with great care, often determine the personality of a model. It creates a elegant space made up of refined shapes enhanced by special processing.



## Manfredi basic

## Accessori / Accessoires

La collezione nasce con l'intento di essere un utile complemento a divani e poltrone dell'attuale collezione, e quindi oggetti neutrali facilmente accostabili a diversi generi di stile e design. Ecco quindi tavolini prettamente tecnici e altri con un gusto più tradizionale, con un occhio alla modernità ma con qualche retaggio classico. Molti gli spunti tratti dalla tradizione rivisti però su una base moderna.

The accessoires collection was created as a useful way of complementing the sofas and armchairs in the current range, so it contains neutral items that are easy to match with different styles and designs. Some of the coffee tables are purely technical and others have a more traditional feel, with the odd classic hint alongside modern features.





## DCV 100

Materiali tradizionali rivisti in nuove forme per dare luce ad un progetto innovativo di tavoli dal design particolare, fuori dagli schemi comuni. Spigoli e rette non sono la base di partenza di questo progetto, dove tutto fluisce, quasi a scorrere.

New takes on traditional materials appear in an innovative assortment of tables with a distinctive design that has broken the mould. This selection does not start with corners and straight lines: everything flows elusively.



## DCV 200



Poche linee ben calibrate determinano un grafismo essenziale in una forma semplice ed elegante. Una proposta essenzialmente semplice, un oggetto esteticamente valido e soprattutto molto funzionale, in grado di assicurare una forte caratterizzazione dello spazio. I dettagli sono il punto forza del modello, ciò che ne determina lo stile e l'identità.

Few well-balanced lines determine an essential graphic style in a simple and elegant form. Simplicity and rationality are the main values of the project; this aesthetically pleasing and highly functional product takes a straightforward, basic approach but it can really make its mark on the identity of a location. Details are the strong point of the model, what determines the style and identity.

Poche linee ben tratteggiate; è il profilo di questo tavolino con piano rotondo disponibile nella versione piccola e alta o in quella più bassa e più grande. Il basamento è formato da un tubo in metallo curvato e verniciato. Oggetti progettati come complementi di un arredo elegante e raffinatoma allo stesso tempo fruibile.

A few well-dashed lines ; is the profile of this coffee table with round top available in the small version and high or the lowest and largest . The base is made by a curved and painted round metal tube. Items designed as complements of an elegant and refined decor but at the same time enjoyable .

DCV 300



DCV 400



DCV 500



Tavoli, tavolini, utili piani d'appoggio per i nostri oggetti, anche di lavoro. Diverse forme e diverse finiture per un ventaglio di proposte che soddisfa vari gusti e vari esigenze. Alti o bassi, quadrati, rotondi o rettangolari, tutti caratterizzati da un design pulito che predilige, oltre all'estetica, la funzionalità.

Tables, coffee tables, useful shelves for our items, also work. Different shapes and different finishes for a range of proposals that satisfies various tastes and different needs. Tall or short, square, round or rectangular, all characterized by a clean design that favors, in addition to aesthetics, functionality.



## DCV 600

Progetto caratterizzato da un design semplice ed elegante e da una grande versatilità che gli consente di essere utilizzato in ambienti diversi sia per esigenze di spazio che per esigenze funzionali. Un programma vario e completo di tavoli di servizio che soddisfa appieno le esigenze del living moderno.

The project is distinguished by simple and elegant design and a great versatility that make it suitable for different environments, spaces and functions. A diverse and complete program of service tables that fully satisfies the needs of modern living.



## DCV 700

Questo tavolo è una miscellanea di eleganza estetica e ottimi ingredienti. La pulizia delle linee lo caratterizza con discrezione e raffinatezza. Moderno formalmente e concettualmente, è un modello di forte impatto visivo. Una soluzione efficace per ambienti importanti nei quali assume un ruolo da vero protagonista.

This table is a blend of aesthetic elegance and excellent ingredients. Uncluttered lines are the features of the discreet, refined table. The result of modern styling, it is a visually stunning model. An effective solution for important environments where it plays a role as a true protagonist.



Una grande attenzione viene dedicata a tutto ciò che fa qualità iniziando dalla lavorazione del prodotto per finire al servizio rivolto al cliente. I prodotti, realizzati interamente nel nostro stabilimento, alla fine del processo produttivo sono sottoposti ad un attento controllo qualitativo. La scelta dei materiali è fondamentale; dai fusti fino ai rivestimenti, tutti i materiali vengono scelti tra i migliori e testati poi con cura prima di essere lavorati. La capacità manuale e sartoriale delle nostre maestranze veste con cura e versatilità prodotti diversi con grande attenzione rivolta al dettaglio.

There is a big focus on all quality-related aspects, covering everything from the production processes to customer service. The products are entirely made in our facilities and they undergo special hand-crafting procedures. At the end of the production process, they are subjected to meticulous quality checks. The choice of materials plays a crucial role. From the frames to the upholstery fabrics, only the finest materials are selected. They are tested with care before being used. Our staff use their manual and sartorial skills with great care and versatility to upholster many different products, showing first-rate attention to detail.

## Una qualità tutta italiana.

### An Italian quality

Dexterity, craftsmanship, expertise and creativity are the core concepts in our special approach to conceiving, designing and making products. The technical and functional qualities of the materials in our products are often invisible, but they can help to establish the style of a home, with a wealth of choices and balanced taste. While quality reigns supreme, creativity enriches the products with quintessentially "Mediterranean" warmth and a sense of both spontaneity and functionality that is invaluable because of its personal, intangible nature. All of this comes together in ever more creative, personalized and inviting homes. The collection has sprung from the company's background but at the same time it marks a turning point on the unique, constantly evolving journey of creative technology in craft production. One big selection of elements that are all compatible with each other, for designing, making and meeting real needs with contemporary creativity that stretches beyond the realm of time.

Manualità, artigianalità, maestria e creatività sono i concetti alla base del modo speciale di immaginare, progettare e realizzare i nostri prodotti. Qualità nascoste sono le qualità tecniche e funzionali dei materiali presenti nei nostri prodotti, spesso invisibili, che offrono la possibilità di definire lo stile della propria casa. Nel contesto della qualità totale, la creatività arricchisce i prodotti con un calore del tutto "mediterraneo" e con dei valori di spontaneità e funzionalità tanto più preziosi, in quanto personali e intangibili, per una casa sempre più creativa, personalizzata e vivibile. Una collezione che nasce dal background aziendale ma allo stesso tempo rappresenta un punto di svolta nell'ambito di un percorso unico, in continua evoluzione: quello della tecnologia creativa delle produzioni artigianali. Un unico, grande complesso di elementi tutti compatibili tra loro, per progettare, realizzare, risolvere esigenze reali con una creatività attuale oltre il tempo.





Pregio estetico, stile, eleganza, cura manuale del particolare e delle finiture: anche negli accessori si intuisce la qualità visibile ed intrinseca di tutti i nostri prodotti.

Nulla viene lasciato al caso, e tutto eseguito con l'estrema cura che è solo di chi ama il proprio lavoro.

La qualità e la cura del dettaglio sono prerogative fondamentali del nostro lavoro. Una costante ricerca stilistica e la maestria dei nostri artigiani consentono di creare oggetti molto particolari, difficilmente riproducibili e di grande prestigio. Pouff, cuscini e accessori non sono mai oggetti banali, ma arricchiscono il divano e lo rendono unico e personalizzabile a seconda del proprio gusto e delle proprie esigenze. Varie le lavorazioni e fantasiose le finiture proposte in tutti gli accessori.

Quality and care for details are important prerogatives for our work. A constant stylistic research together with our craftsmen creative skills allow to create very particular items, difficult to reproduce and of great prestige. Our poufs, cushions and accessories are never ordinary items, they embellish the sofa make it unique, customisable according to the clients taste and requirements. We offer various manufactures and imaginative finishes for all our accessories.

La cura del dettaglio / Care for details.



CVD 110 cuscini / cushions



CVD 111 cuscini / cushions



CVD 112 cuscini / cushions



CVD 113 cuscini / cushions



CVD 114 cuscini / cushions





Fellini

Schienale STD

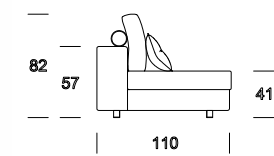

Schienale OPT

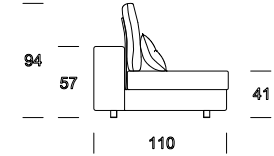

VOLUME OFFSET / OFFSET VOLUME

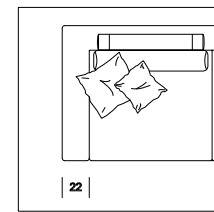
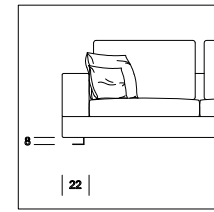

Poltrona centrale

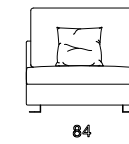

Poltrona terminale SX

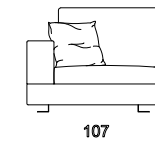

Poltrona terminale DX

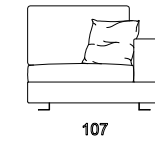

Divano

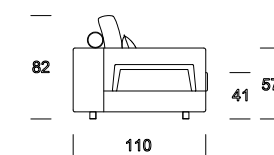

Divano

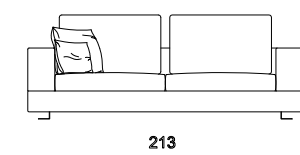

Divano

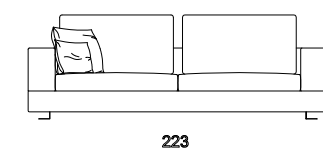

Divano

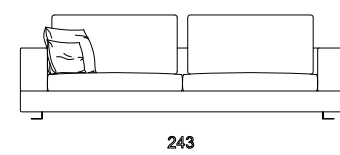

Divano letto

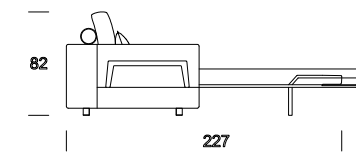

Divano letto

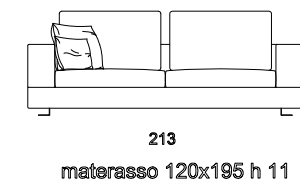

Divano letto

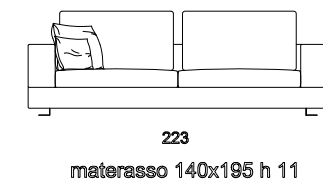

Divano letto

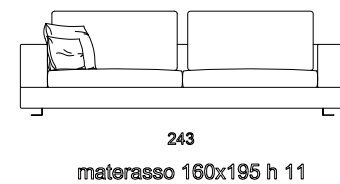

Divano terminale SX

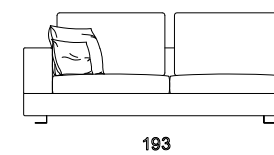

Divano terminale DX

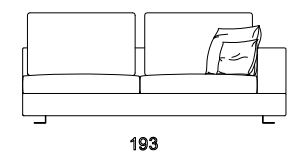

Divano terminale SX

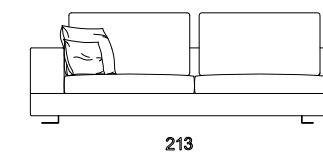

Divano terminale DX

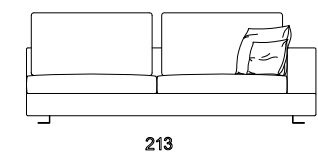

Divano terminale SX

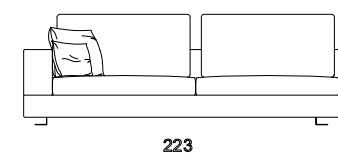

Divano terminale DX

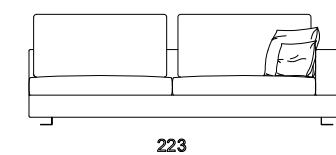

Divano terminale letto SX

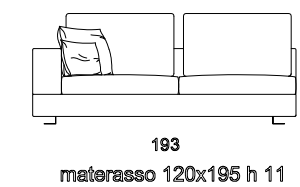

Divano terminale letto DX

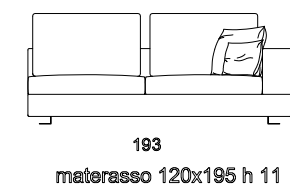

Divano terminale letto SX

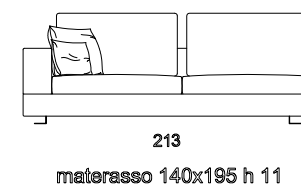

Divano terminale letto DX

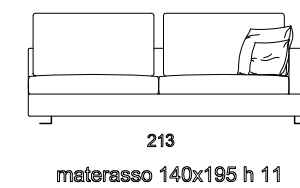

Divano terminale letto SX

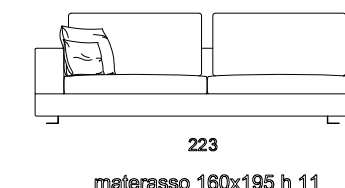

Divano terminale letto DX

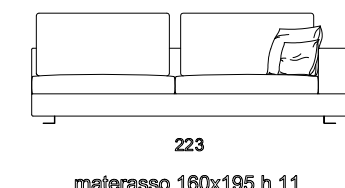

Elementi imbottiti completamente sfoderabili nella versione in tessuto. Per le versioni in pelle, sfoderabili solo cuscini seduta e schienale. Struttura portante in legno massello, cuscini seduta in piuma d'oca naturale con inserto in poliuretano ad elevata densità. Schienali in misto piuma. Finiture e piedi in metallo.

Completely removable covers on all padded parts of the version with fabric upholstery. Only the seat and backrest cushions are removable on versions with leather upholstery. Solid wood structure and natural goose feather seat cushions with high density polyurethane foam inserts. Feather blend backrests. Metal finishing and feet.

Divano centrale

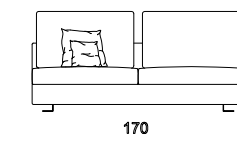

Divano centrale

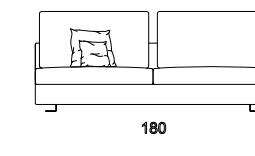

Divano centrale

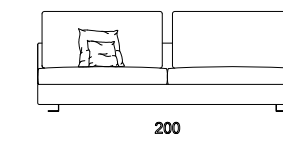

Divano centrale letto

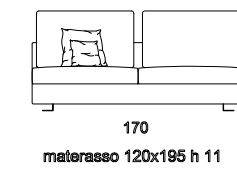

Divano centrale letto

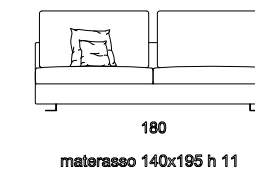

Divano centrale letto

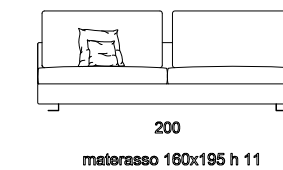

Angolo

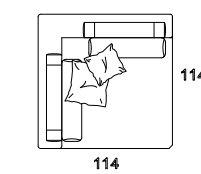

Chaise large SX

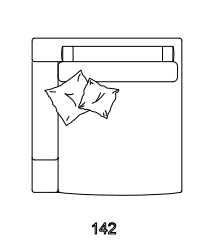

Chaise large DX

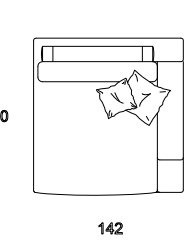

Chaise longue SX

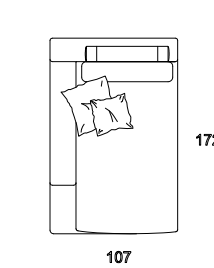

Chaise longue DX

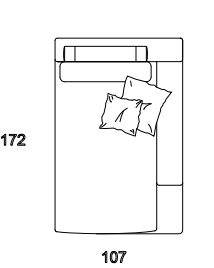

Chaise large con tavolo

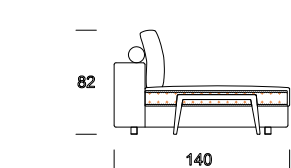

Chaise large con tavolo SX

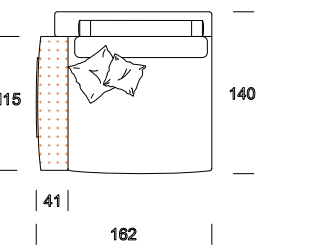

Chaise large con tavolo DX

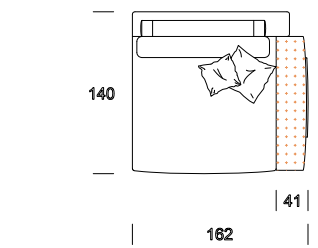

Tavolo ad angolo

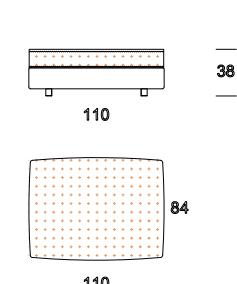

Pouff

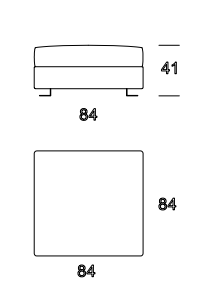

Pouff con tavolo

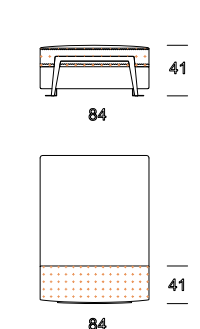

Pouff

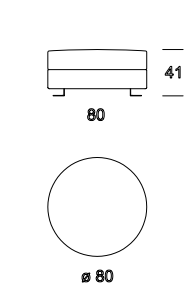

Composizione 1

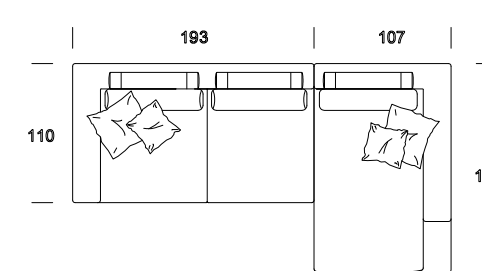

Composizione 2

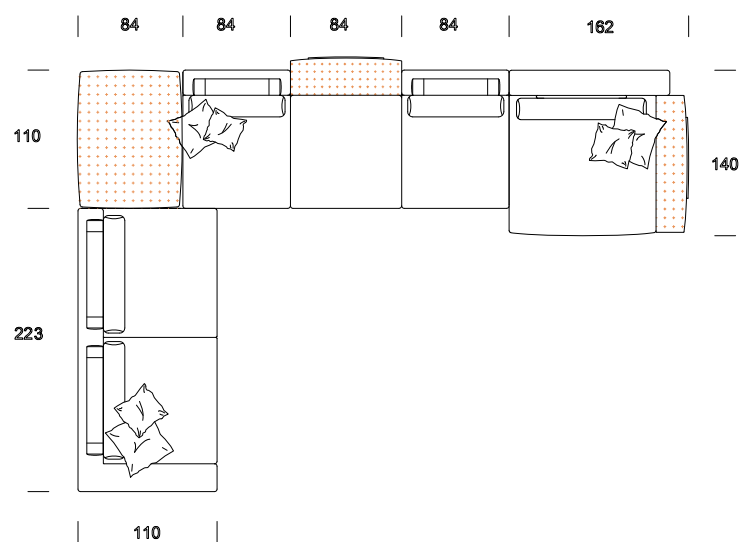

Composizione 3





Mastroianni

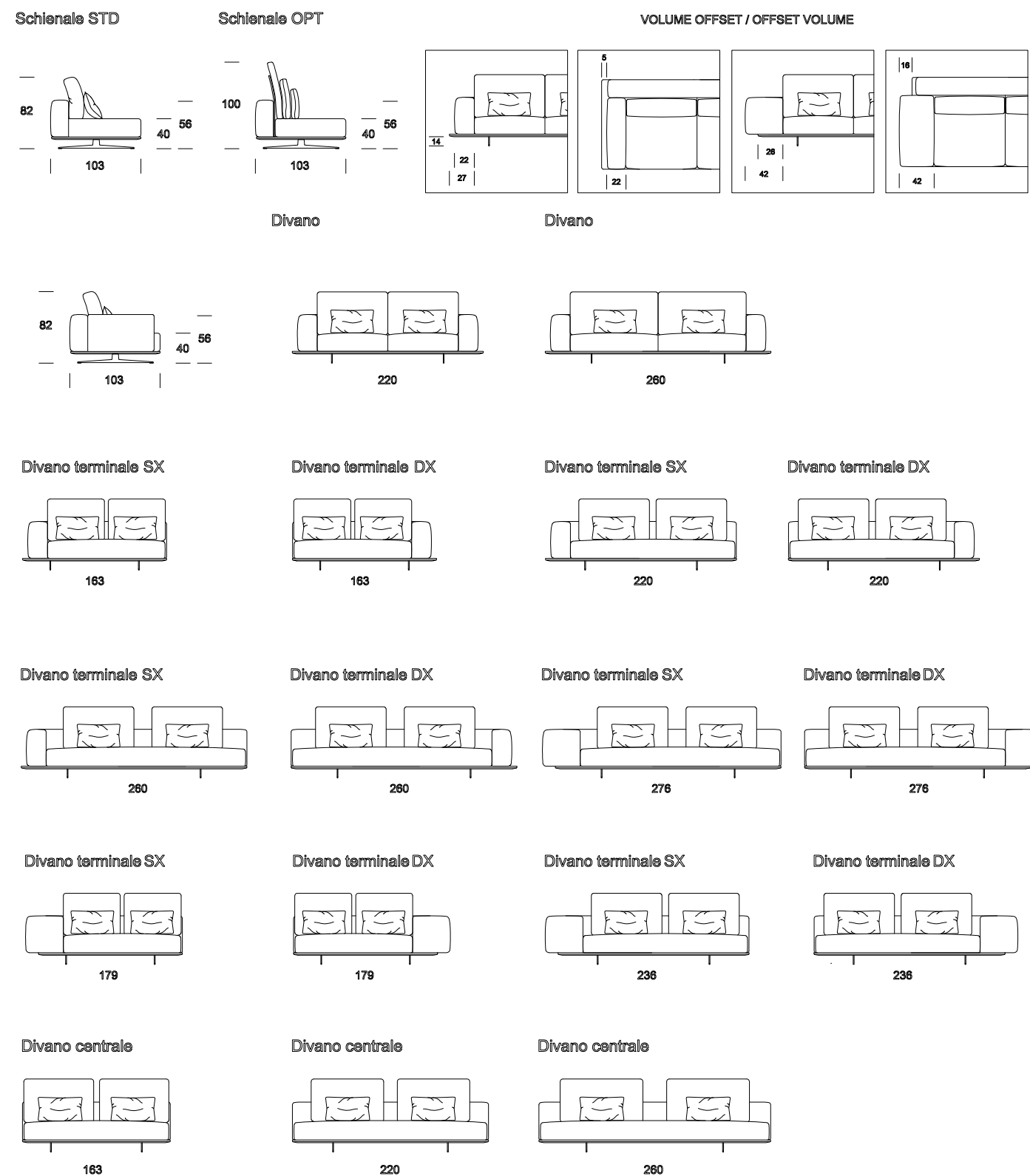

Struttura portante in multistrato, cuscini seduta in piuma d'oca naturale con inserto in poliuretano, schienali in misto piuma. Cuscini schienale, seduta e parte della struttura sfoderabili. Per i rivestimenti in pelle saranno sfoderabili solo cuscini seduta e schienale. Piedi in metallo.

Plywood structure, natural goose feather cushions with polyurethane foam inserts and feather blend backrests. Removable covers on the seat and backrest cushions and part of the structure. With leather upholstery, only the seat and backrest cushions are removable. Metal feet.

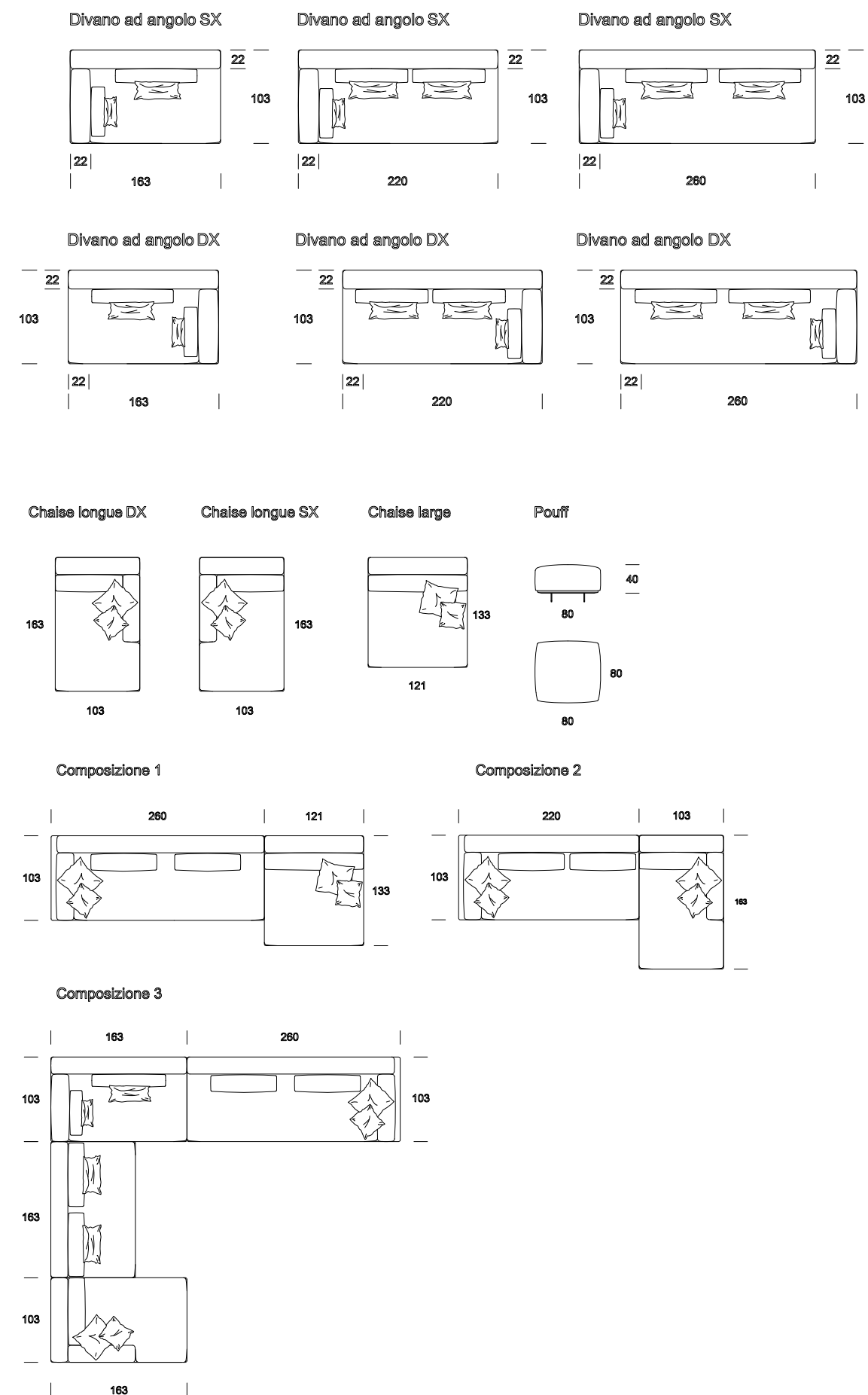



Manfredi



Manfredi basic

Poitrone terminale

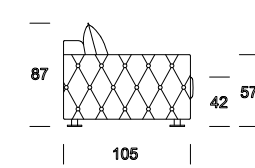

Poitrone terminale SX

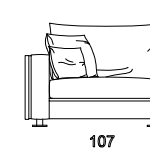

Poitrone terminale DX

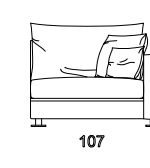

VOLUME OFFSET / OFFSET VOLUME

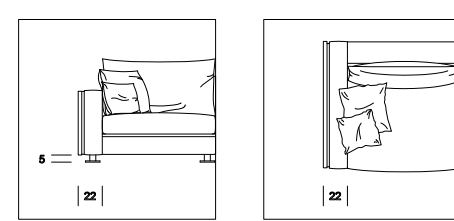

Divano

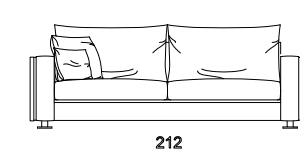

Divano

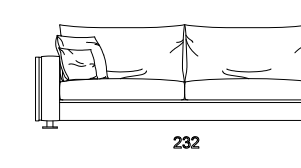

Divano

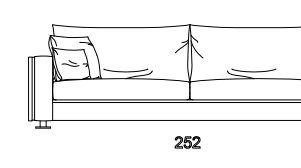

Divano letto

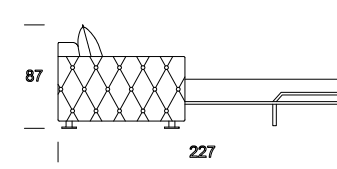

Divano letto

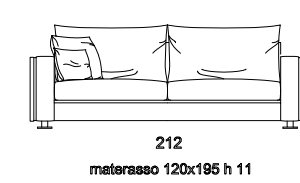

Divano letto

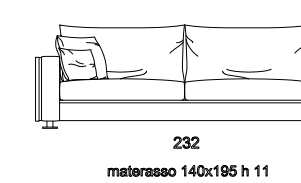

Divano letto

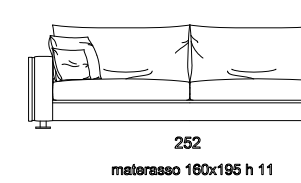

Divano terminale SX

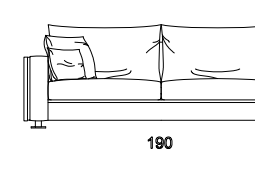

Divano terminale DX

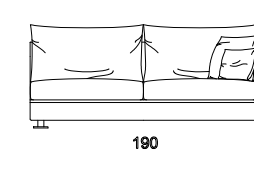

Divano terminale SX

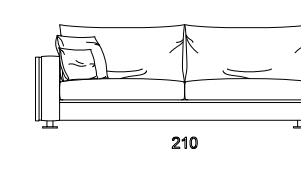

Divano terminale DX

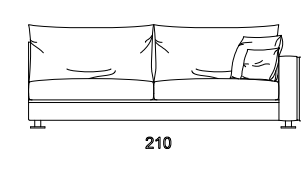

Divano terminale SX

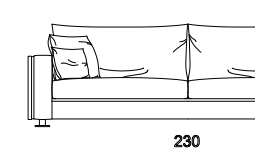

Divano terminale DX

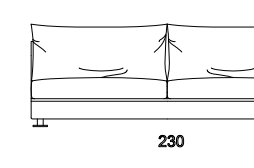

Divano terminale letto SX

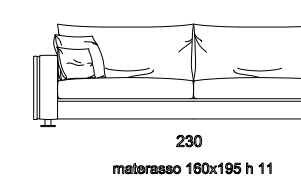

Divano terminale letto DX

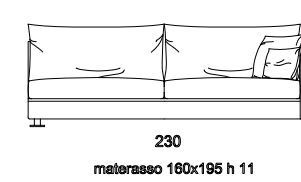

Divano terminale letto SX

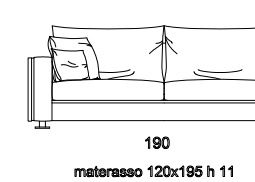

Divano terminale letto DX

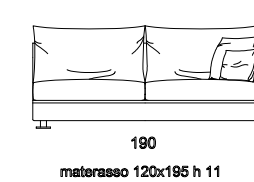

Divano terminale letto SX

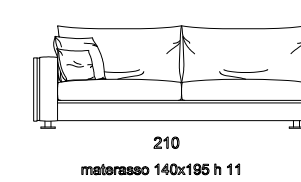

Divano terminale letto DX

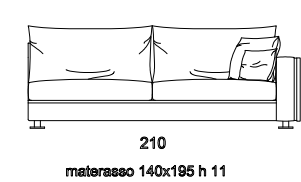

Divano centrale

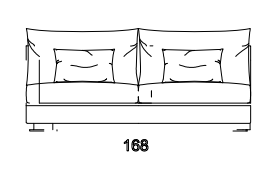

Divano centrale

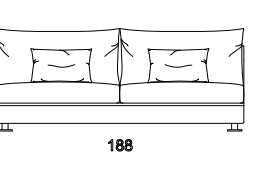

Divano centrale

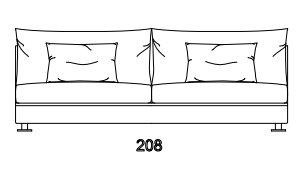

Divano centrale letto

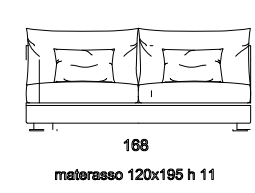

Divano centrale letto

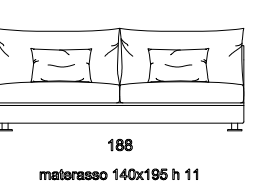

Divano centrale letto

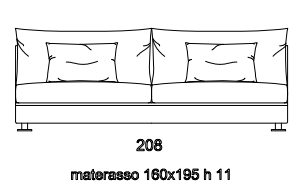

Struttura portante in legno massello, cuscini seduta in piuma naturale con inserto in poliuretano ad elevata densità, cuscini schienale in misto piuma. Cuscini seduta e schienale sfoderabili. Finiture e piedi in metallo.

Solid wood structure, natural feather seat cushions with high density polyurethane foam inserts and feather blend backrests. Seat and backrest cushions with removable covers. Metal finishing and feet.

Poitrone centrale

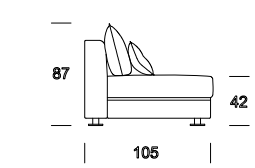

Angolo

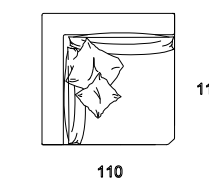

Pouff

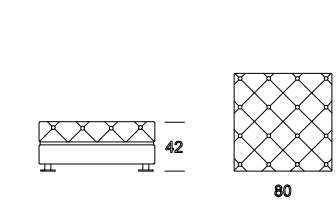

Chaise longue SX

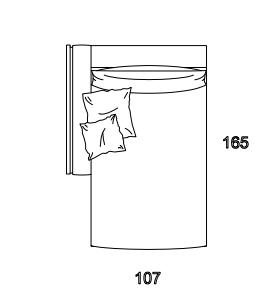

Chaise longue DX

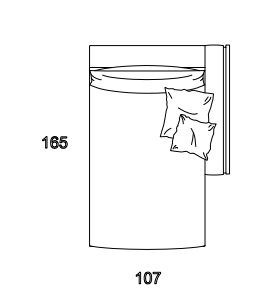

Chaise large SX

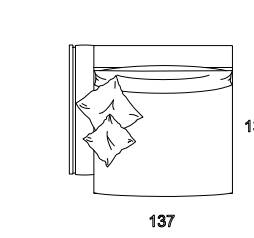

Chaise large DX

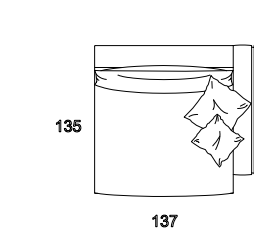

Composizione 1

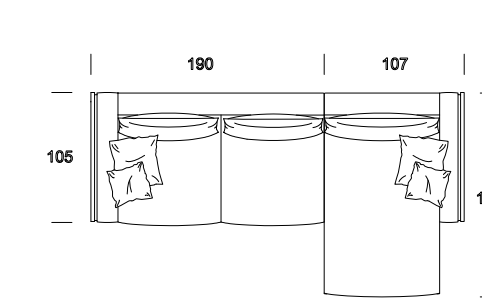

Composizione 2

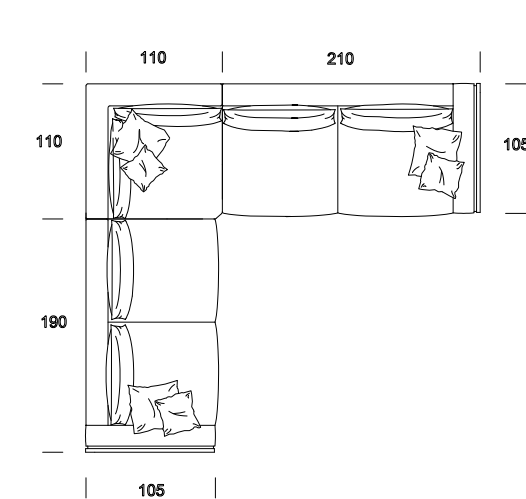

Composizione 3

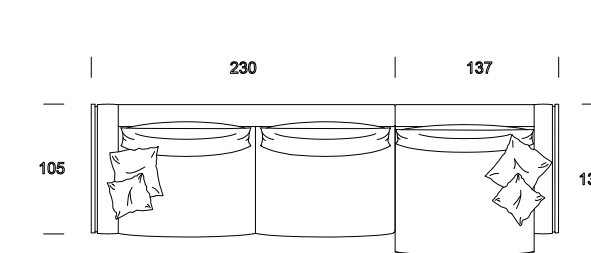

Composizione 4

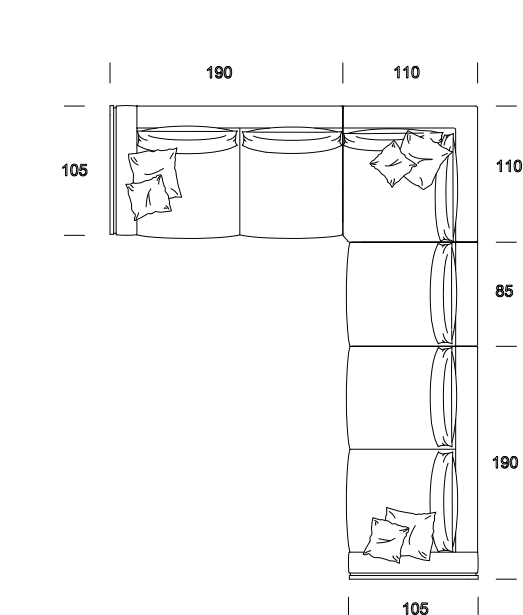



Visconti



Visconti plus

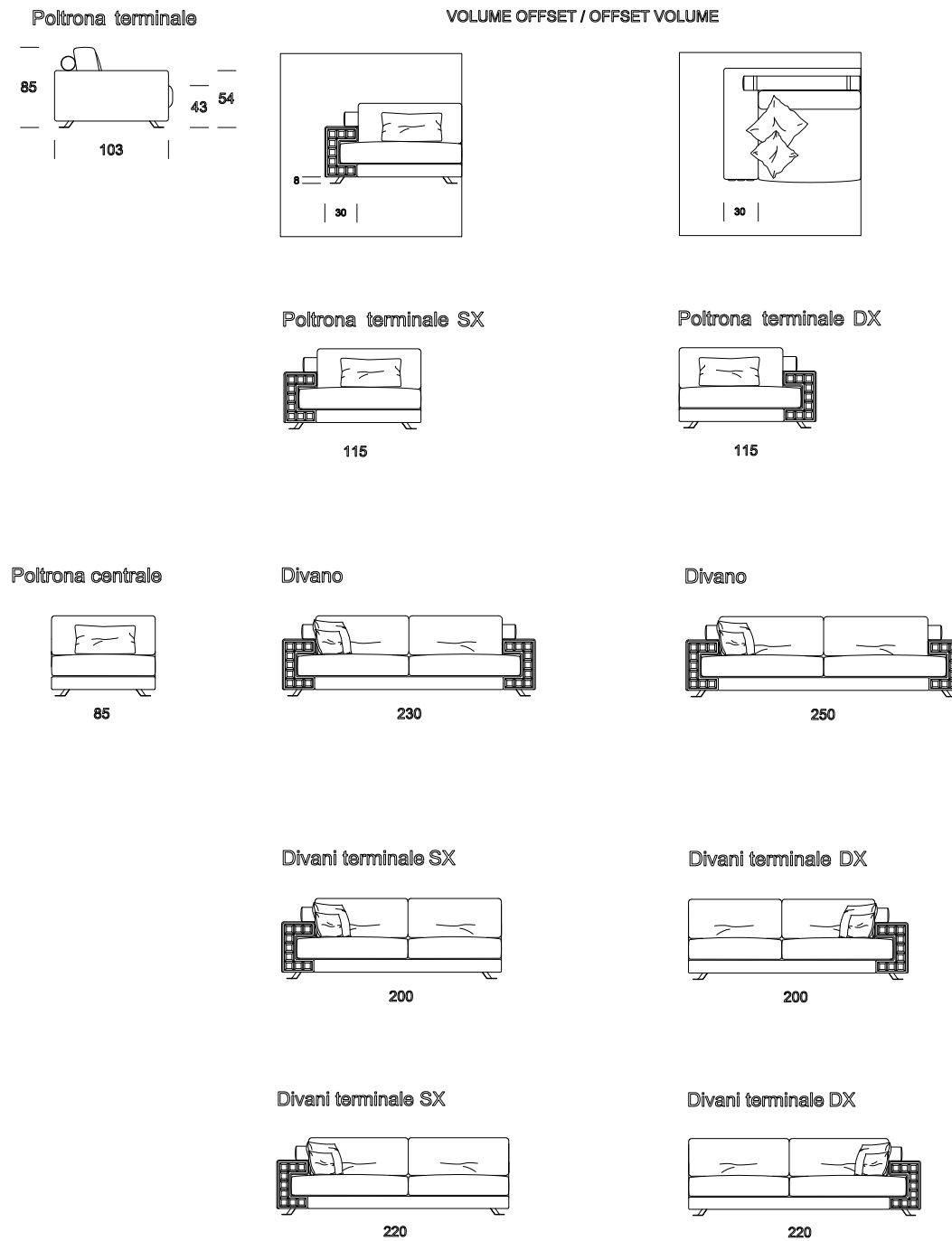

Struttura portante in legno massello, cuscini seduta in poliuretano ad elevata densità rivestiti in dacron, schienali in misto piuma. Cuscini seduta e schienale sfoderabili. Finiture: piedi in metallo. Frontale braccioli caratterizzato da formelle in vetro a specchio o su richiesta interamente imbottito.

A solid wood structure with high density polyurethane foam seat cushions covered with PET and feather blend backrests. Seat and backrest cushions with removable covers. Finishes: metal feet. Armrest fronts with mirrored glass panels or fully upholstered on request.

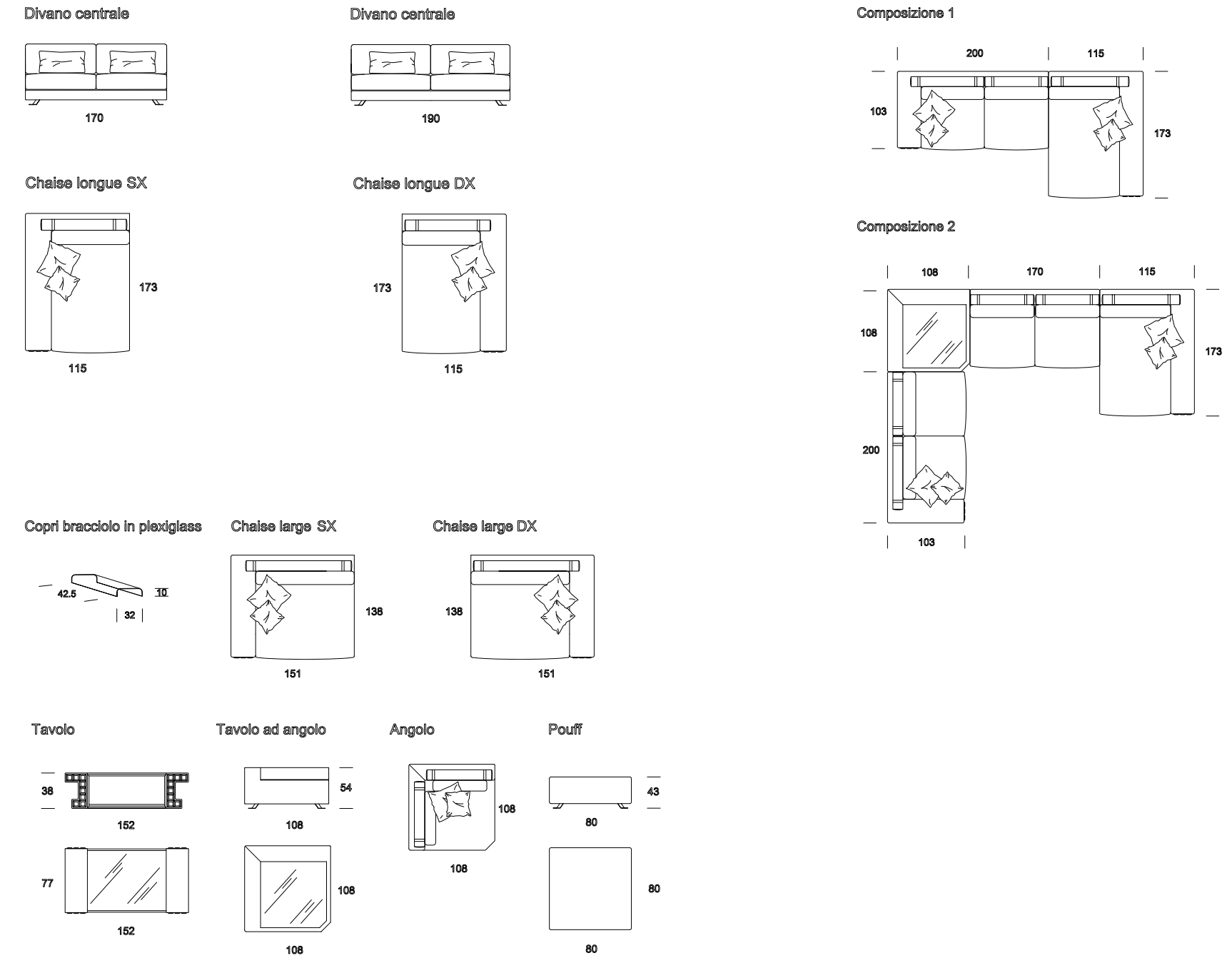



## Michelangelo

Sistema parete modulare e componibile composto da moduli con due larghezze (cm. 100 e cm. 150). Ripiani e mobile contenitore basso in MDF spessore 25 mm impiallacciati in legno di teak o in noce canaletto con finitura opaca o lucida. I moduli a contenitore sono completi di cassetti con frontali in metallo curvo e sagomato in finitura bronzo. A richiesta, personalizzabile in tutte le finiture RAL. Sostegni verticali in acciaio inox satinato

*A modular wall system allowing combinations of modules of two widths (100 cm and 150 cm). Shelves and bottom container unit made of 25 mm thick MDF with a teak or canaletto walnut veneer and a matt or gloss finish. The container units come with drawers with shaped, curved metal fronts with a bronze finish. On request elements are customizable in any of the RAL finishes. Brushed stainless steel vertical supports.*

Mensola 100x45

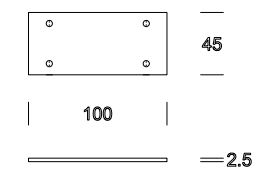

Modulo cm.100

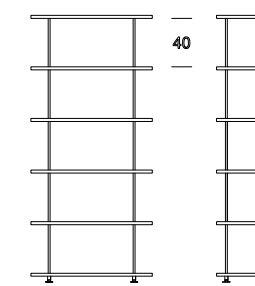
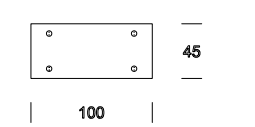

Libreria componibile - Composizione 1

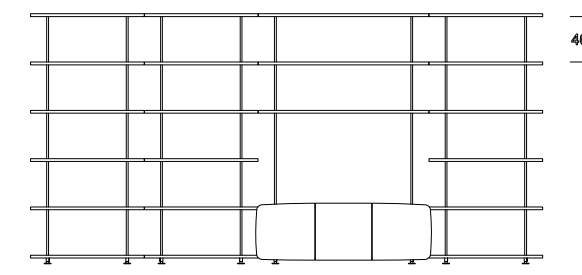
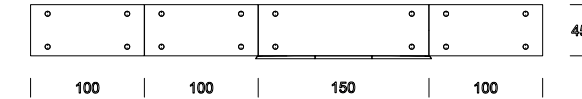

Libreria componibile - Composizione 3

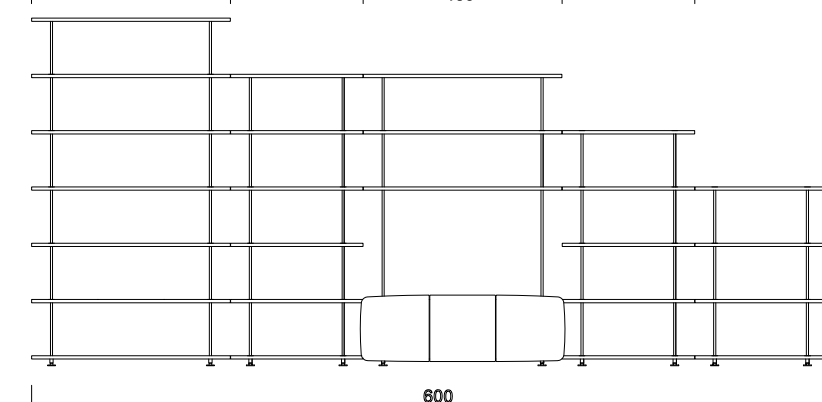
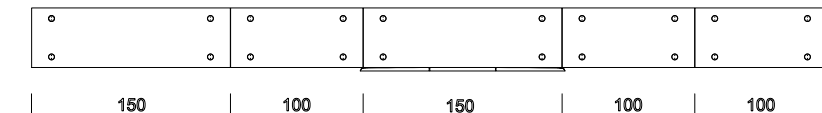

Mensola 150x45

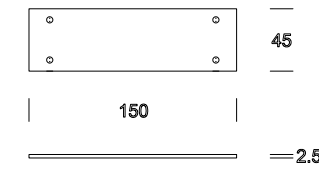

Modulo cm.150

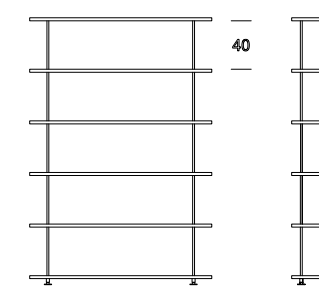
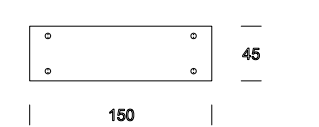

Cassettiera

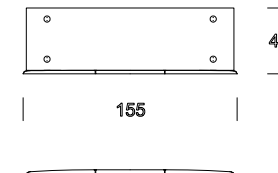

Modulo TV / Cassettiera

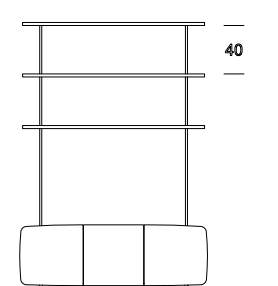
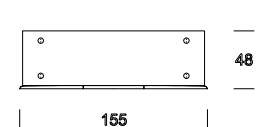

Libreria componibile - Composizione 2

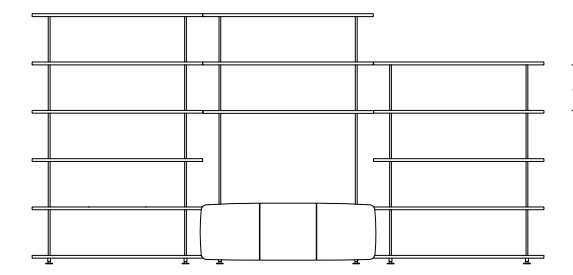
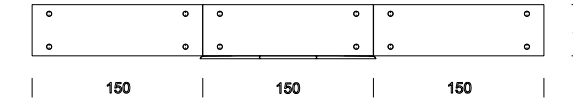

Modulo Cassettiera



Modulo Cassettiera

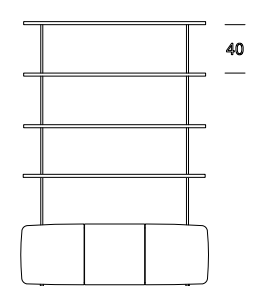
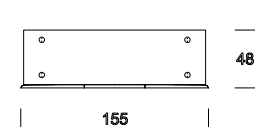

## Totò

Tavolo

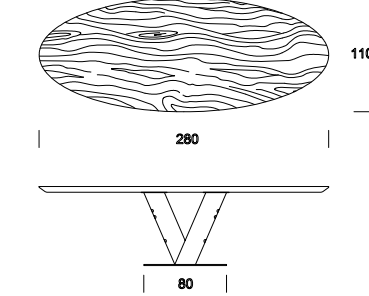

Tavolo

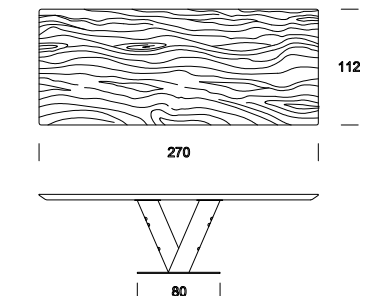

Tavolo

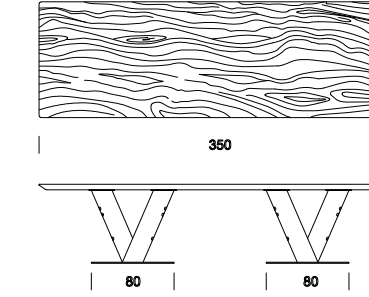

Tavolo

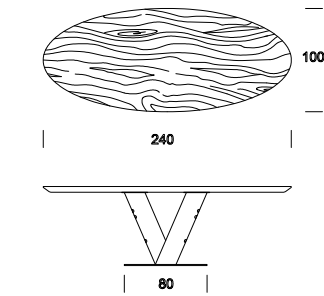

Tavolo

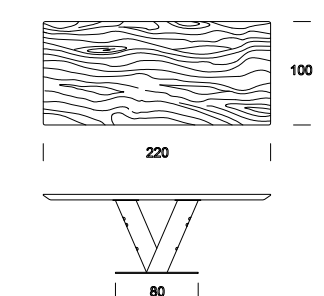

Tavolo



Tavolo

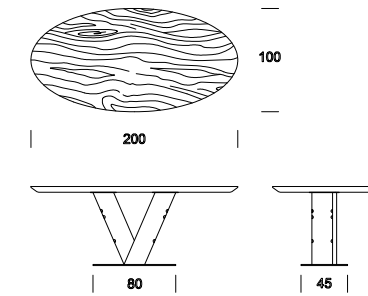

Tavolo

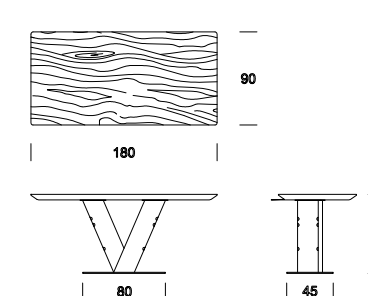

Tavolo con basamento in acciaio dalla doppia finitura, bronzo e acciaio satinato. Piano in legno, affusolato verso i bordi esterni, spessore 50 mm impiallacciato in teak o in noce canaletto con finitura opaca o lucida. A richiesta, è disponibile in tutte le finiture RAL.

*A table with a steel base featuring a double bronze and brushed steel finish. The wooden top is 50 mm thick and tapered towards the edges, with a teak or canaletto walnut veneer and a matt or gloss finish. On request, is available in all of the RAL finishes.*



## Anita

Sedia

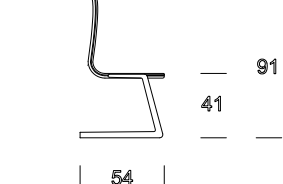
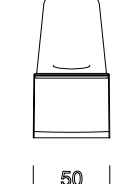
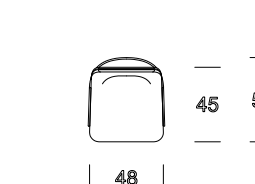

Struttura interna in legno curvato su stampo imbottito in poliuretano. Il basamento è verniciato color oro all'interno mentre l'esterno è in acciaio satinato. E' disponibile una seconda versione di basamento più economico il quale avrà la finitura RAL in un unico colore. Rivestimento in pelle o tessuto.

*A bent wood internal structure on a polyurethane foam padded mould. The base has a golden coating inside, with a brushed steel exterior. A less expensive base is also available, with a single colour RAL finish. Leather or fabric upholstery.*



Tavolo da caffè laccato

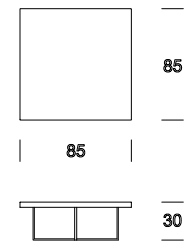

Tavolo da caffè laccato

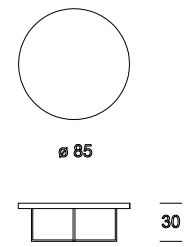

Tavolo da caffè marmo

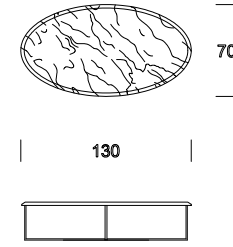

Tavolo da caffè marmo

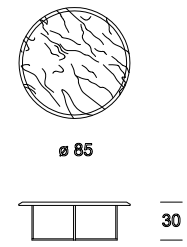

DCV 700

Basamento in metallo cromato, piano in legno laccato bianco / nero  
Chrome metal base, white/black lacquered wooden top

Basamento in metallo cromato, piano in marmo emperador / onice / calacatta  
Chrome metal base, emperador / onice / calacatta marble top



Tavolo da caffè in cristallo M130x32

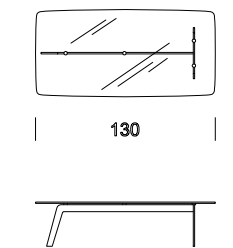

Tavolo da caffè in cristallo M75x45

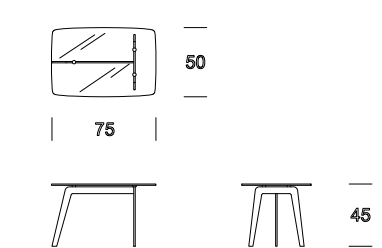

DCV 500

Basamento in acciaio, piano in cristallo fumè.  
Steel base, smoked glass top



Tavolo da caffè

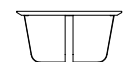
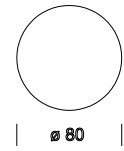

Tavolo da caffè

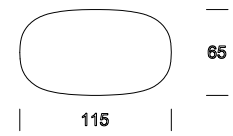

Tavolo da caffè

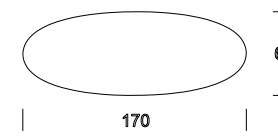

DCV 600

Basamento in metallo verniciato grigio,  
piano in legno laccato grigio seta o rovere

Metal base with grey coating,  
oak or silk grey lacquered wooden top



Servetto notebook in cristallo

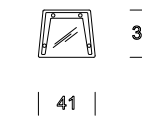

DCV 400

Basamento in acciaio, piano in cristallo fumè.  
Steel base, smoked glass top

Tavolo da caffè RIALTO

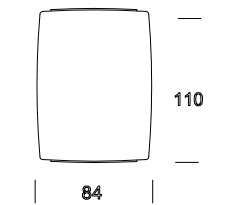

DCV 800

Piano in legno rivestito in pelle o ecopelle, parte in metallo verniciato bronzo.  
Wooden top covered with leather or artificial leather, metal part with bronze coating



Tavolo da caffè

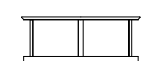
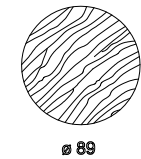

Tavolo da caffè



DCV 100

Basamento in metallo verniciato bianco o nero, piano in legno rovere o noce canaletto

Metal base with white or black coating, oak or black walnut wooden top



Tavolo servetto laccato

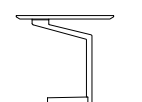
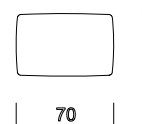

DCV 401

Basamento in acciaio, piano in legno laccato bianco o grigio.  
Steel base, white or grey lacquered wooden top

Tavolo servetto a piattro laccato

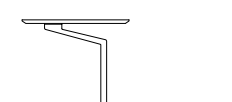
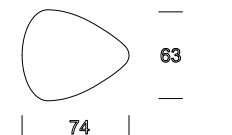

DCV 402

Basamento in acciaio, piano in legno laccato bianco o grigio.  
Steel base, white or grey lacquered wooden top



DCV 300

Tavolo da caffè



Ø 45



48

Tavolo da caffè

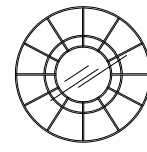

Ø 103

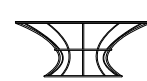

42

Basamento in metallo verniciato nero, piano in vetro

Metal base with black coating, glass top



DCV 200

Tavolo

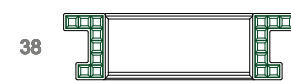

38

152

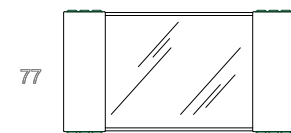

77

152

Struttura imbottita e rivestita; frontali in quadrotte di specchio.  
Piano in vetro su telaio in acciaio

Padded end upholstered structure; frontal made with mirrored squares.  
Glass top on metal frame

## Dolcevita Collection

Art Direction / Concept: Beatrice Carollo

Photo: Gianni Sabbadin

Fotolito: Colorediting

Stampa: SAT Pesaro

Stampato nel mese di aprile 2016



FORMERIN ITALIA srl  
Via Emilia Romagna 2  
61020 Gallo (Pesaro) Italia  
tel. ++39 0722 52176  
fax ++39 0722 52640  
www.formerin.it  
e-mail: info@formerin.it



*www.former.in.it*