

REINVENT





REINVENT

è la linea di serramenti ideali
per sostituire i tuoi vecchi infissi e
donare nuova vita alla tua casa.

REINVENT is the ideal line of doors
and windows for replacing your
old ones and injecting new life
into your home.

REINVENT est la ligne de menuiseries
idéale pour remplacer vos anciennes
menuiseries et donner une nouvelle
vie à votre maison.



IL PIACERE DI UN NUOVO COMFORT

The pleasure of new comfort
Le plaisir d'un nouveau confort

DQG 70 EVO

ANTA	
Sash Vantail	77 MM
TELAIO	RESTAURO
Frame Châssis	Renovation casing Aile rénovation
CAMBIO BATTUTA	
Central mullion Battement central	STANDARD
NODO CENTRALE	
Mullion sash-frame Meneau central	162 MM

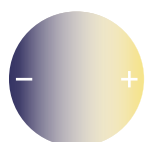

LUCE
LIGHT / LUMIÈRE





BENESSERE DI LUCE DAL DESIGN MINIMAL

The wellbeing of light with minimal design
Un bien-être lumineux au design minimaliste

DQG 70 EVO MIX

ANTA	
Sash	69 MM
Vantail	
TELAIO	RESTAURO
Frame	Renovation casing
Châssis	Aile rénovation
CAMBIO BATTUTA	
Central mullion	STANDARD
Battement central	
NODO CENTRALE	
Mullion sash-frame	146 MM
Meneau central	

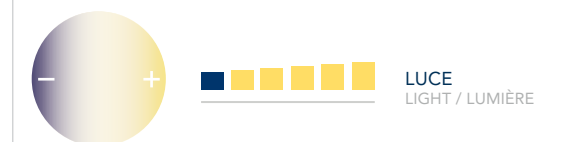



MENO PROFILO, PIÙ LUCE

Less profile, more light
Moins de profils, plus de lumière

DQG 70 EVO

ANTA	
Sash	77 MM
Vantail	
TELAIO	RESTAURO
Frame	Renovation casing
Châssis	Aile rénovation
CAMBIO BATTUTA	
Central mullion	MORE LIGHT
Battement central	
NODO CENTRALE	
Mullion sash-frame	126 MM
Meneau central	

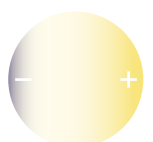

LUCE
LIGHT / LUMIÈRE



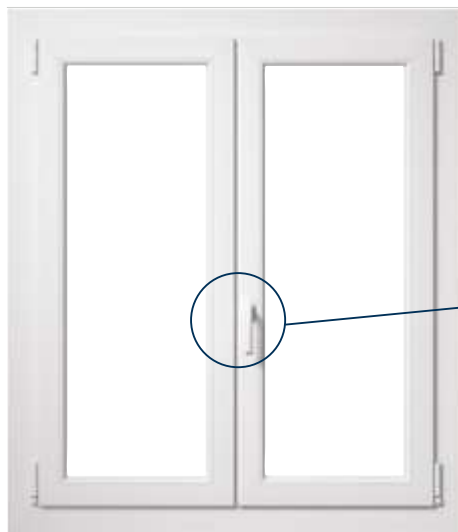

DQG 70 EVO



> 162 MM <

ANTA	
Sash Vantail	77 MM
TELAIO	
Frame Châssis	RESTAURO Renovation casing Aile rénovation
CAMBIO BATTUTA	
Central mullion Battement central	STANDARD

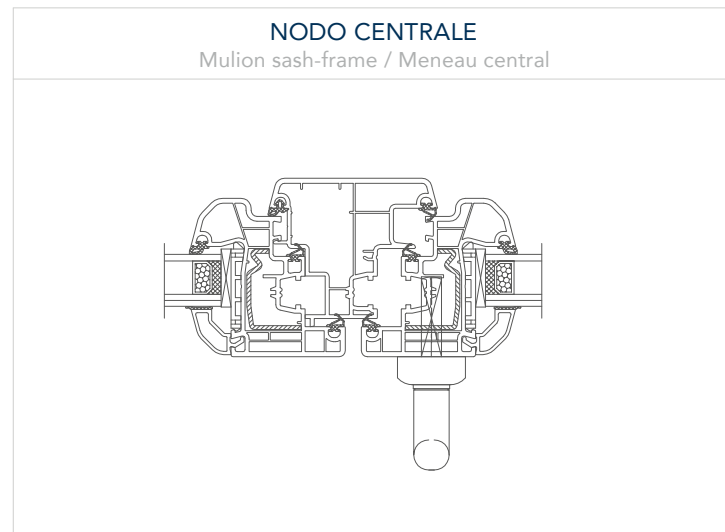
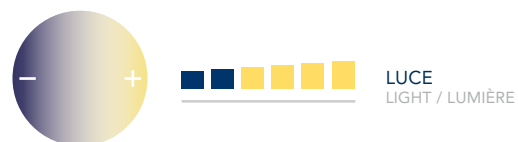

NODO CENTRALE
Mulion sash-frame / Meneau central

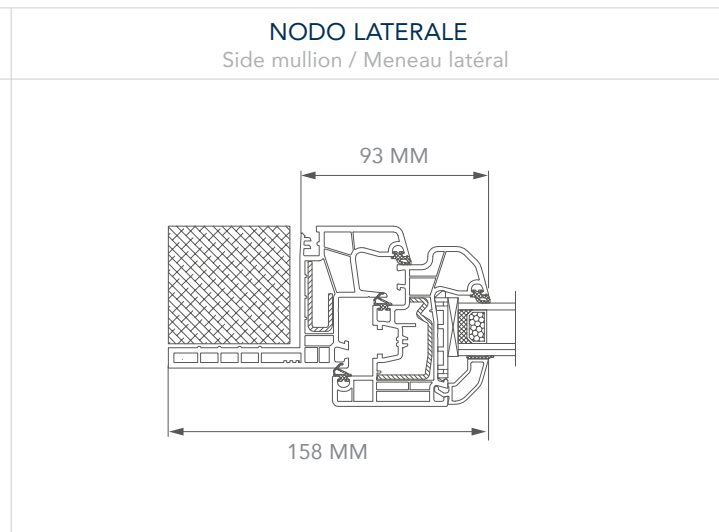

NODO LATERALE
Side mullion / Meneau latéral

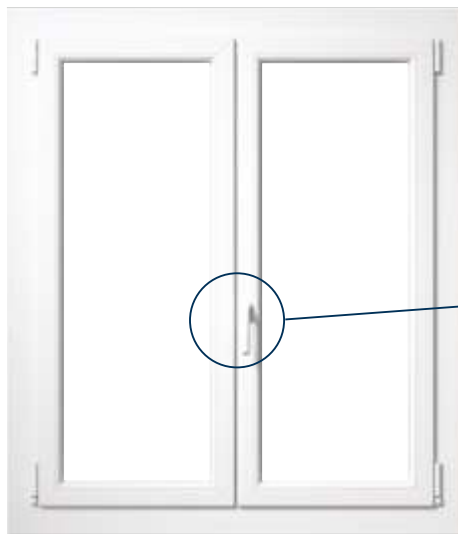
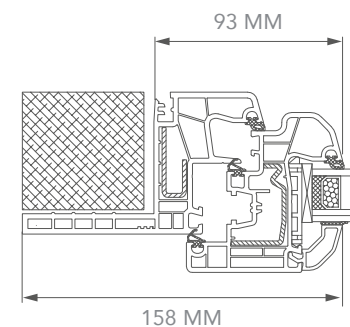

DQG 70 EVO MIX

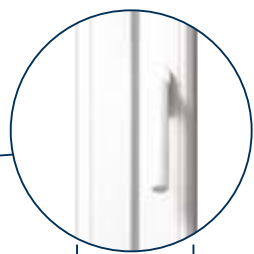

> 146 MM <

ANTA	
Sash Vantail	69 MM
TELAIO	
Frame Châssis	RESTAURO Renovation casing Aile rénovation
CAMBIO BATTUTA	
Central mullion Battement central	STANDARD

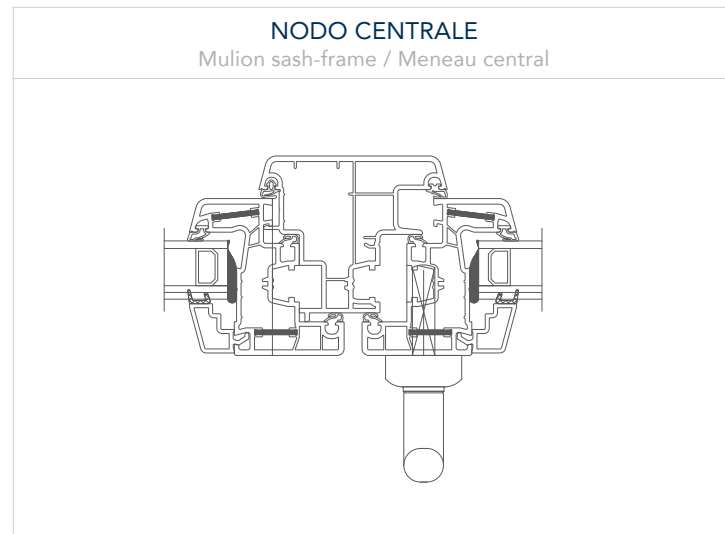
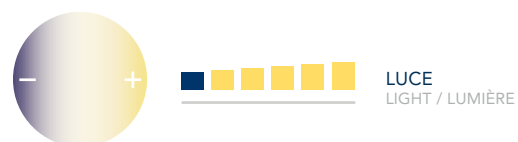

NODO CENTRALE
Mulion sash-frame / Meneau central

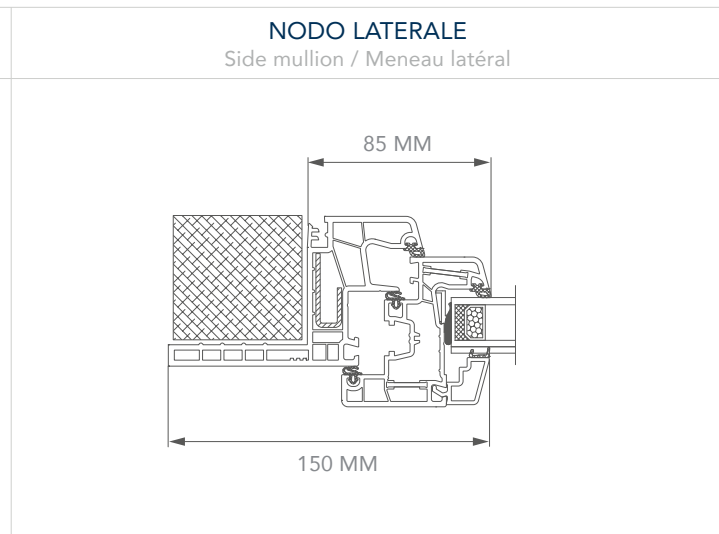

NODO LATERALE
Side mullion / Meneau latéral

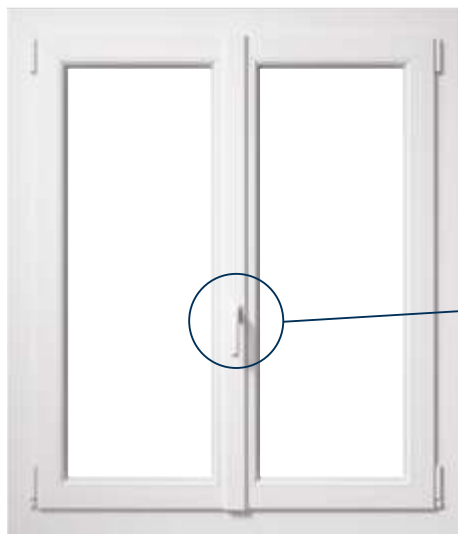
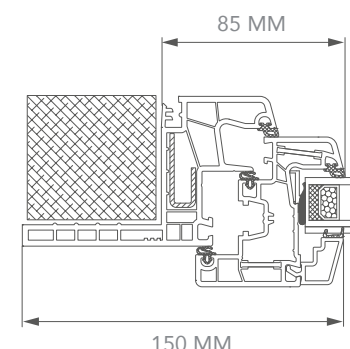

DQG 70 EVO

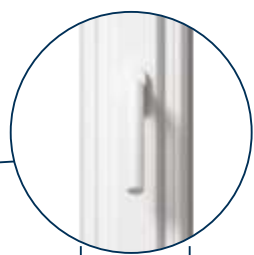

> 126 MM <

ANTA	
Sash Vantail	77 MM
TELAIO	
Frame Châssis	RESTAURO Renovation casing Aile rénovation
CAMBIO BATTUTA	
Central mullion Battement central	MORE LIGHT

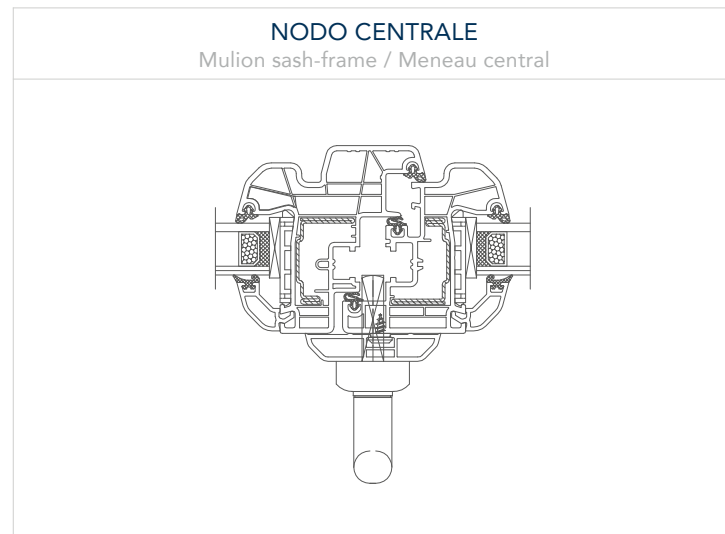
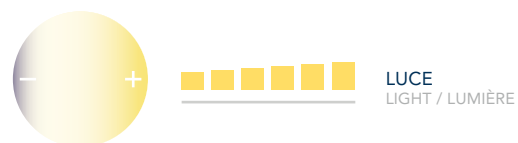

NODO CENTRALE
Mulion sash-frame / Meneau central

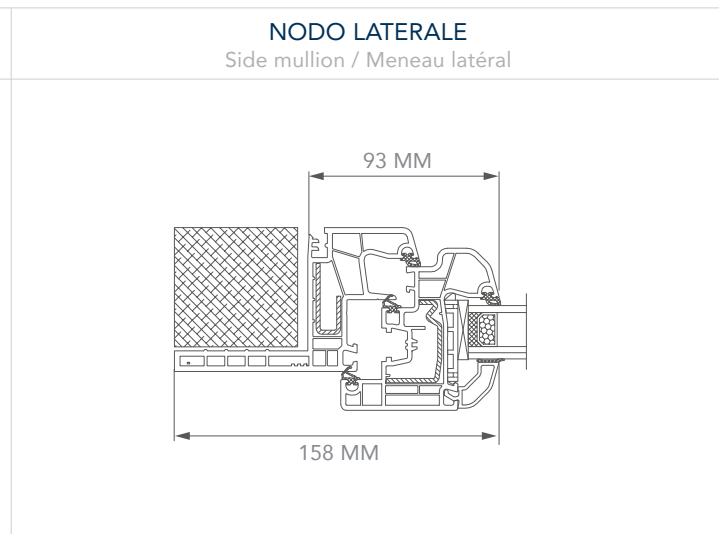

NODO LATERALE
Side mullion / Meneau latéral

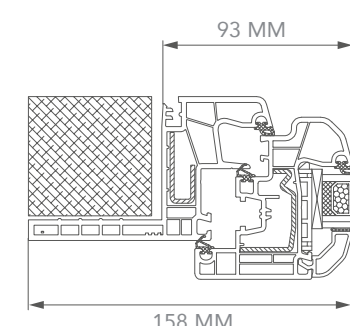

PERCHÉ CAMBIARE GLI INFISSI?

Why change your doors and windows ? / Pourquoi changer vos menuiseries ?



RIQUALIFICAZIONE ENERGETICA ED ACUSTICA

ENERGY AND ACOUSTIC UPGRADING
REQUALIFICATION ÉNERGÉTIQUE ET ACOUSTIQUE

Cambiare i vecchi serramenti significa ottenere nell'immediato due grandi vantaggi: un elevato abbattimento del rumore proveniente dall'esterno ed una riduzione drastica della dispersione termica sia in estate che in inverno.

Changing your old doors and windows means obtaining two immediate advantages: much less noise coming in from outside and a drastic reduction in heat dispersion during both summer and winter.

Changer d'anciennes menuiseries signifie bénéficier immédiatement de deux grands avantages: une forte atténuation du bruit provenant de l'extérieur et une réduction drastique de la déperdition thermique, aussi bien en été qu'en hiver.



RISPARMIO ECONOMICO

YOU SAVE MONEY
ÉCONOMIES SUR LE PLAN FINANCIER

La diminuzione di dispersione energetica si traduce in una considerevole riduzione del dispendio economico! Diminuiscono infatti i costi di riscaldamento in inverno e quelli di condizionamento in estate.

Less heat dispersion means a considerable reduction in waste! Your heating costs will reduce during winter, as will your air conditioning costs during summer.

La diminution de la déperdition d'énergie se traduit en une réduction notable de la dépense, en termes financiers! En effet, les coûts de chauffage en hiver et ceux de climatisation en été diminuent.



DETRAZIONI FISCALI

TAX DEDUCTIONS
ABATTEMENTS FISCAUX

Sostituendo i serramenti, puoi beneficiare di importanti agevolazioni fiscali. Perché non approfittarne?

Replacing your doors and windows gives you the benefit of important tax deductions. Why not take advantage?

En remplaçant vos menuiseries, vous pouvez bénéficier d'importants abattements fiscaux. Pourquoi ne pas en profiter?

PERCHÉ I BENEFICI SONO INFINITI!

Because the benefits are infinite ! / Car les avantages sont infinis !



SICUREZZA

SAFETY
SÉCURITÉ

I serramenti di ultima generazione offrono di serie un alto livello di sicurezza contro i tentativi di effrazione. Una componente importante per te e la tua famiglia.

All our new generation doors and windows offer high levels of protection against burglar, very important for you and your family.

Les menuiseries de dernière génération offrent, de série, un niveau de sécurité élevé contre les tentatives d'effraction. Un élément important pour vous et votre famille.



RIVALUTAZIONE DELLA CASA

MORE VALUABLE
RÉÉVALUATION DE LA VALEUR DE VOTRE MAISON

Aumenta considerevolmente il valore sia reale che percepito della tua abitazione.

The actual and perceived value of your home increase considerably.

Le changement de menuiseries augmente de façon notable aussi bien la valeur réelle que celle perçue de votre habitation.



MAGGIORE BENESSERE

GREATER WELLBEING
UN PLUS GRAND BIEN-ÊTRE

Cambiare i serramenti significa vivere meglio! Eccellenti prestazioni energetiche, elevato abbattimento acustico, alti livelli di sicurezza, risparmio economico consentono un notevole miglioramento del comfort abitativo.

Changing windows and doors means living better! Your living comfort improves notably because energy performances are excellent, noise levels are much lower, safety levels are higher, and you also spend less.

Changer vos menuiseries signifie mieux vivre! Excellentes prestations énergétiques, forte atténuation acoustique, niveau de sécurité élevé, économies en termes financiers permettent une amélioration notable du confort d'habitation.

Le foto illustrative e le informazioni tecniche contenute nella presente brochure sono indicative e possono essere modificate, anche senza preavviso, a discrezione di Diquigiovanni srl in qualsiasi momento. Tutte le parti di questa brochure, foto comprese, sono di proprietà di Diquigiovanni srl. La riproduzione, anche parziale, è vietata in ogni forma e con ogni mezzo.

The photos and the technical information contained in this brochure are provided by way of example and are, therefore, subject to change at any time without advanced warning, at the discretion of Diquigiovanni srl. All parts of this brochure including the photos, are property of Diquigiovanni srl. All reproduction, even partial, is prohibited in any form and by any means.

Les photos et les informations techniques présentées dans cette brochure sont indicatives et peuvent être modifiées à tout moment, même sans préavis, à la discrétion de Diquigiovanni srl. Toutes les parties de cette brochure, photos comprises, sont de propriété de Diquigiovanni srl. Toute forme de reproduction, même partielle, est interdite.

DQG
WINDOWS FOR LIFE



Diquigiovanni[®]
windows for life

DIQUIGIOVANNI SRL - P. IVA 02943611208
Via Torri di Confine 2/1 int. B - 36053 Gambellara (VI) Italy
☎ +39 0444 124 11 00 - 📠 +39 0444 124 10 91
info@diquigiovanni.com - www.diquigiovanni.com