

Catalogo Tecnico



Il giardino di legno





Il giardino di legno

Catalogo Tecnico







COLLECTIONS

| | | | |
|-------------------|------|----------------------|-------|
| ADAMAS: | p 16 | MOZAIC: | p 100 |
| ALICE: | p 18 | OTTO: | p 106 |
| ARGALI: | p 20 | PEBBLES: | p 108 |
| AVALON: | p 22 | PORTER: | p 110 |
| BERBEDA: | p 24 | RADICE: | p 112 |
| BONGO: | p 28 | RATIO: | p 114 |
| CLASSICA: | p 30 | REGISTA: | p 118 |
| DEHOR: | p 42 | RIVIERA: | p 120 |
| EMILY: | p 46 | SAINT LAURENT: | p 122 |
| FIJI: | p 48 | SAINT RAPHAEL: | p 124 |
| FOSSIL: | p 52 | SAINT TROPEZ: | p 128 |
| GEORGETOWN: | p 54 | SAVANA: | p 134 |
| GIAVA: | p 60 | SENTOSA: | p 144 |
| GIPSY: | p 62 | SUAR: | p 150 |
| INFINITY: | p 66 | TONGA: | p 162 |
| JUNIOR: | p 68 | VENEZIA: | p 168 |
| LOGIKA: | p 70 | VITTORIA: | p 178 |
| LUI & LEI: | p 72 | WAIKIKI: | p 180 |
| MACAO: | p 76 | WAPITI: | p 184 |
| MANHATTAN: | p 82 | WHITE SAND: | p 186 |
| MAUI: | p 84 | ZEFIRO: | p 188 |
| MOON: | p 92 | | |

MORE

| | | | |
|------------------|-------|--------------------|-------|
| ACCESSORI: | p 190 | MAINTENANCE: | p 220 |
| DESIGNERS: | p 218 | OMBRELLONI: | p 212 |
| FINISHING: | p 221 | TILES: | p 160 |

IL GIARDINO DI LEGNO

Il Giardino di Legno progetta e produce con passione nel settore dell'arredamento, con particolare attenzione alla lavorazione del legno ed ai materiali per l'outdoor.

Il carisma silenzioso e le eclettiche competenze professionali ne caratterizzano non solo la produzione ma anche il supporto offerto al cliente e al progettista. La combinazione armonica di molteplici professionalità scaturisce in un gruppo di lavoro che affronta ogni progetto come una sfida, ogni richiesta del cliente come una mission, ogni ricerca di un nuovo materiale come uno stimolo per l'approfondimento delle proprie esperienze e conoscenze.

Una raccolta di oggetti d'arredo in cui differenti essenze, materiali e cromie si mescolano e si miscelano nel processo creativo per offrire nuove soluzioni ed essere fonte d'ispirazione per l'arredamento del vostro Giardino di Legno.

Il Giardino di Legno designs and produces furniture with passion, focusing in particular on woodwork and outdoor materials.

The quiet charisma and the versatile professional skills characterize not only our production but also the support offered to all customers and designers. Our many different abilities combine seamlessly to give birth to great teamwork: we consider every project as a challenge, every request as a mission, every search for a new material as a way to boost and broaden our knowledge and experience.

In our furniture line, different essences, materials and colours are mixed and blended in the creative process so as to offer new solutions and become a source of inspiration when decorating your garden.





STTR0807
STTR0808
STTR0809
STTR0814
RATI0525
ACCS0804
STTR0214
STTR0215







STRA0221
STRA0222
STRA0223
STRA0446
RATIO319
RATIO417

WAIK4508
SAVA0458
ZOSW3030







TONG4201
TONG4202
TONG4301
TONG4403
TONG4404



ADAMAS

design by A3DIMENSIONI

Struttura in acciaio inox a finitura satinata. Piano del tavolo in doghe di Teak. Sedute e schienali delle sedie in filo di poliestere rivestito in PVC tessuto e saldato ad alta frequenza. Braccioli in Teflon® o massello di Teak. Lettini da sole con rivestimento in fibra sintetica, Batyline® o massello di Teak. Proposto in teak finitura naturale, fibra sintetica colore Banana Leaf, Batyline nero.

Stainless steel structure with satin finish. Teak slats table top. Seats and backs of the chairs in PVC covered polyester wire, woven and high frequency welded. Arms in Teflon® or Teak wood. Sun loungers with synthetic fibre coating, Batyline® or Teak wood. The standard finishing is Fine Sanded teakwood, Banana Leaf synthetic fibre, Black Batyline sling.

ADAM5501



ADAM5314



ADAM5503



ADAM5401



ADAM5501

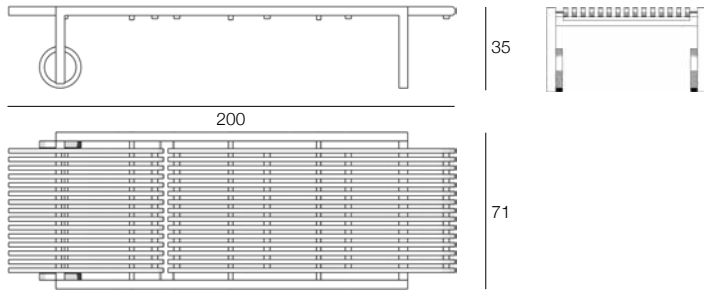

ADAM5503

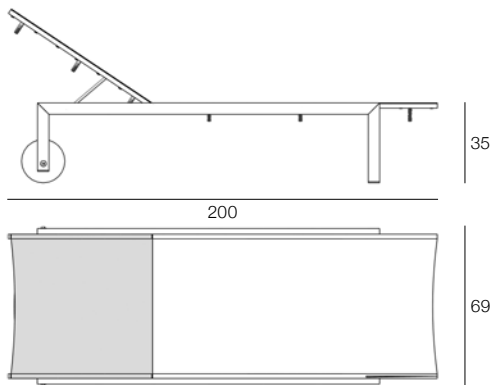

ADAM5314

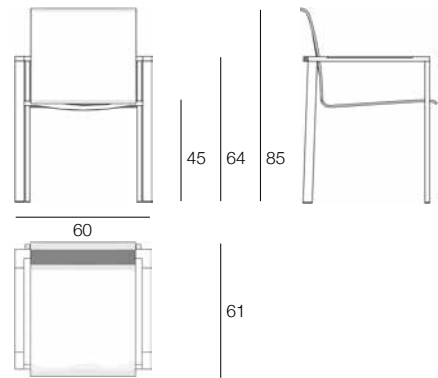

ADAM5401

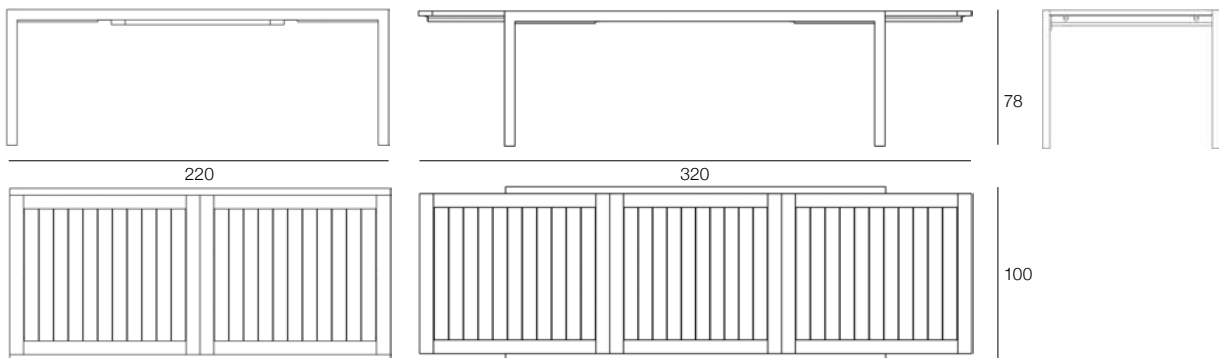

ALICE

design by CRS SILAT

ALIC0243 + ALIC0243-CUS

Realizzata in rattan naturale intrecciato a mano e finito con finitura pigmentata *natural* semi-lucida e dettagli in nero. Tavolini con piano intrecciato in vimini e sopra-piano in vetro. Piedini in Teflon. La linea comprende i tavolini bassi rotondi, dalla base traforata, e la poltrona con ampio schienale arrotondato dalla forma simile a quella della coda di un pavone: riproposizione della famosa 'Peacock chair' con dettagli in nero. Adatta ad esterni coperti.

Made of hand-woven natural rattan with semi-glossy natural color finish and black details. Occasional and low tables with woven wicker and glass top. Teflon feet. The line includes low round tables, with perforated base, and the armchair with generously-sized rounded peacock-tail backrest: a reinterpretation of the famous "Peacock chair", detailed in black. Suitable for covered outdoor spaces.



ALIC0475



ALIC0476



ALIC0243

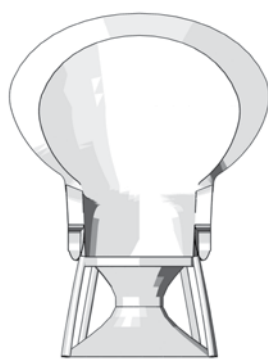

111

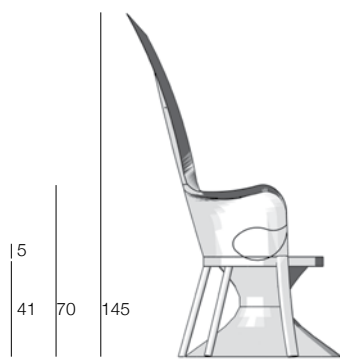

83

5
41
70
145

ALIC0475



46

52

ALIC0476



48

38



ALIC0243
ALIC0475

ARGALI

design by CRS SILAT

Struttura in alluminio vergine, intreccio in fibra sintetica estrusa a sezione rotonda "Core", a base polietilenica, da 2,7mm nei colori White Wash e Cappuccino alternati. Piedini in Teflon. Tavolino con sovrappiano in vetro disponibile su richiesta. I cuscini sono realizzati in poliuretano espanso con fodera di protezione interna e copertura in tessuto acrilico sfoderabile. Proposto in fibra sintetica Core intrecciata nei colori Cappuccino e White Wash.

Virgin aluminium frame, woven with 2.7 mm round "Core" polyethylene based extruded synthetic fibre in alternated White Wash and Cappuccino colour. Teflon feet. Low table with glass top available on request. Polyurethane foam cushions with internal protective lining and removable acrylic fabric cover. Standard finishing is in Cappuccino and White Wash Core synthetic fibre.

ARGA4216 + ARGA4216-CUS



ARGA4320 + ARGA4320-CUS



ARGA4429 + ARGA4429-CUS



ARGA4430

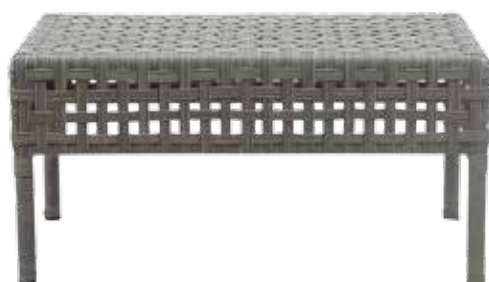

ARGA4430+ARGA4430-GLS

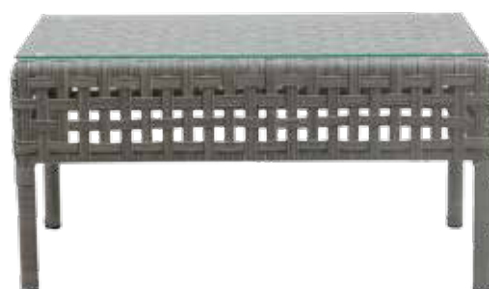

ARGA4216

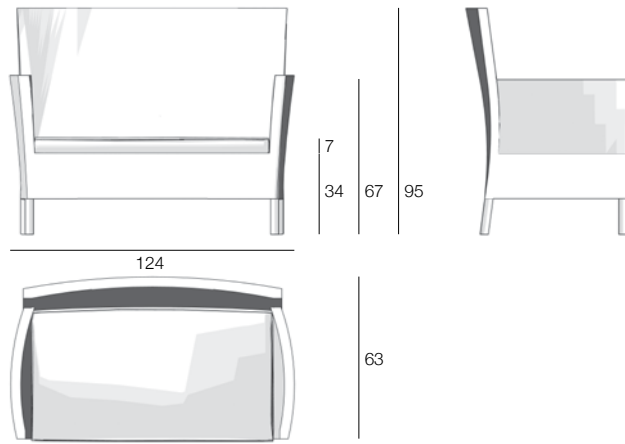

ARGA4320

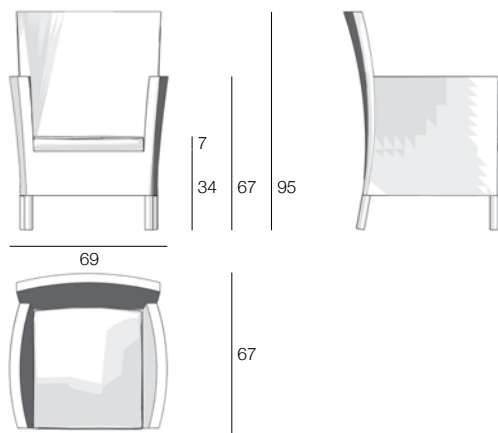

ARGA4429

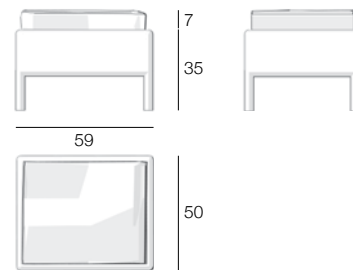

ARGA4430

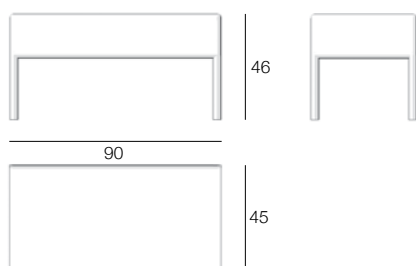

AVALON

design by FEDERICA FERRARA

Struttura in tondino di acciaio inox a finitura satinata. Sedute e schienali in filo di poliestere rivestito in PVC tessuto e saldato ad alta frequenza. Svitando la connessione tra le gambe le sedie possono essere impilate. Proposto in Batyline® nero.

Stainless steel rod structure with satin finish. Seats and backs in polyester PVC covered wire, woven and high frequency welded. Unscrewing the legs, the chairs can be stacked. Standard version comes in black Batyline®.

AVAL5312



AVAL5313



AVAL5312

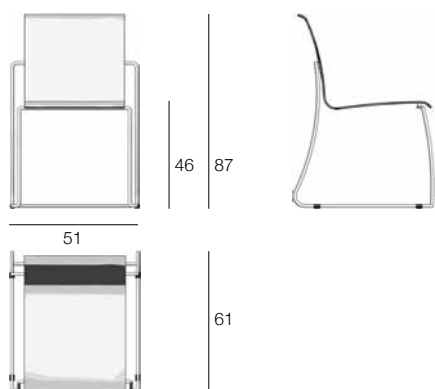

AVAL5313

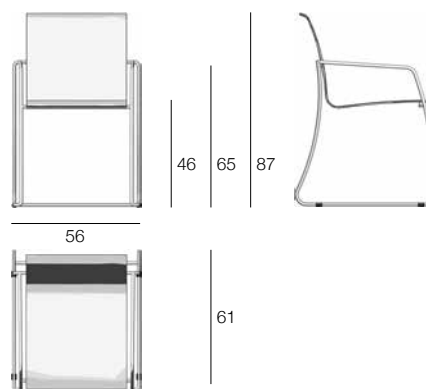

BERB5406
AVAL5312
AVAL5313
TILT2501



BERBEDA

design by CRS SILAT

Struttura in acciaio inox a finitura satinata. Sedute e schienali delle sedie impilabili disponibili in filo di poliestere rivestito in PVC tessuto e saldato ad alta frequenza, in fibra sintetica o in massello di Teak. Piani dei tavoli in massello di Teak o vetro satinato. Proposto in Teak finitura naturale, fibra sintetica colore Banana Leaf, Batyline® nero.

Stainless steel structure with satin finish. Seats and backs available in polyester PVC covered wire, woven and high frequency welded, synthetic fibre or Teak wood. Stackable chairs. Teak wood or frosted glass table surface. Standard finishing is Fine Sanded teakwood, Banana Leaf synthetic fibre, Black Batyline® sling.

BERB5201



BERB5202



BERB5301



BERB5410



BERB5306



BERB5304



BERB5307



BERB5411



BERB5201

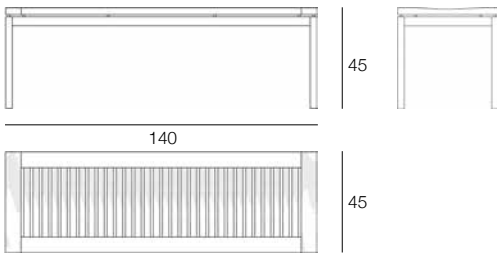

BERB5202

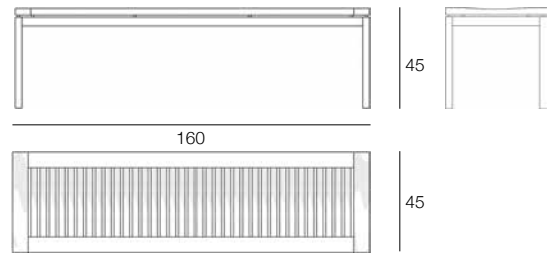

BERB5301

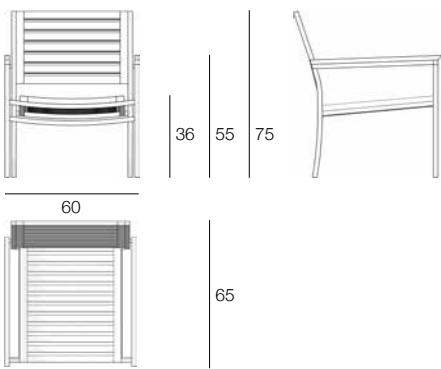

BERB5410

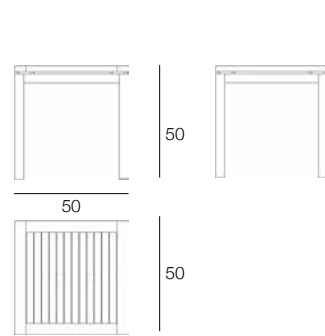

BERB5304

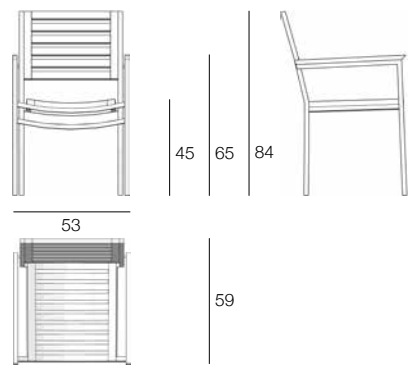

BERB5306

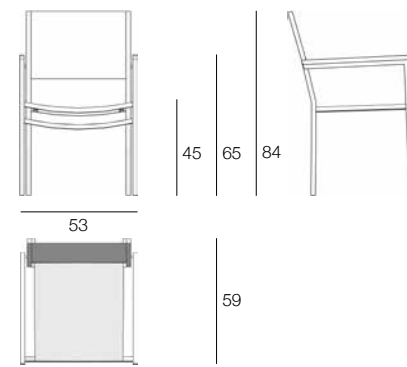

BERB5307

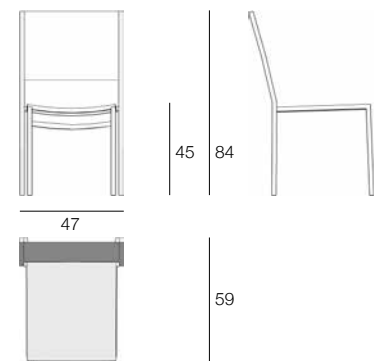

BERB5411

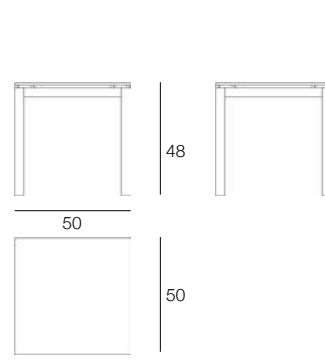

BERB5403



BERB5405



BERB5406



BERB5408



BERB5308



BERB5409



BERB5403

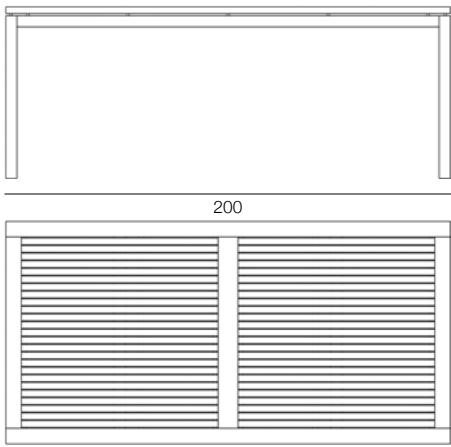

BERB5406

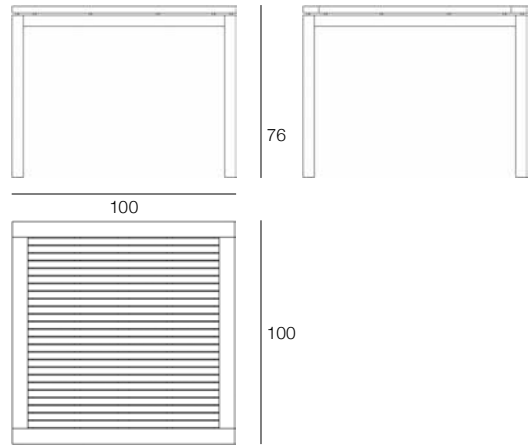

BERB5405

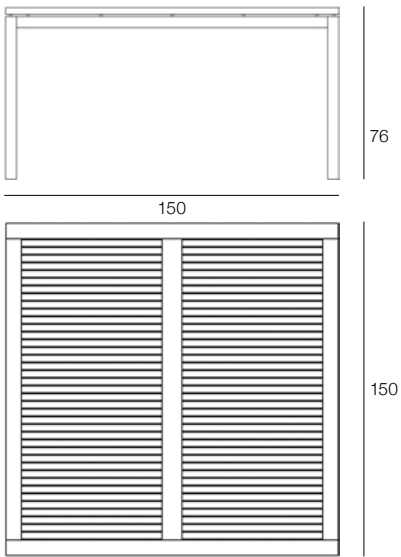

BERB5408

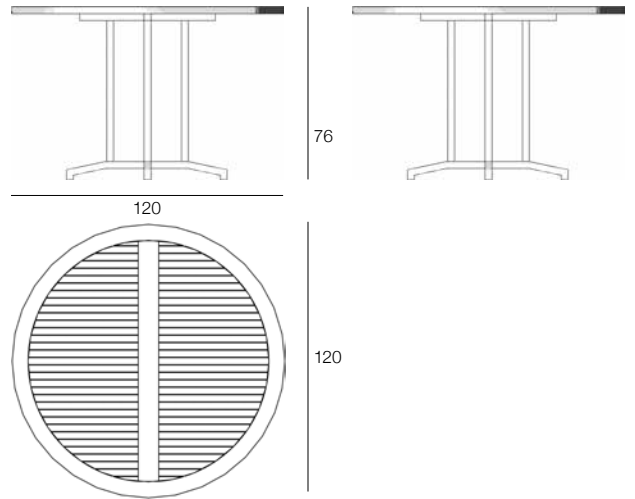

BERB5308

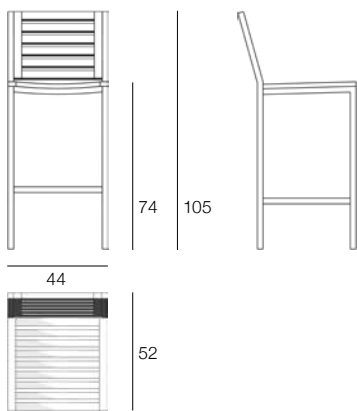

BERB5409

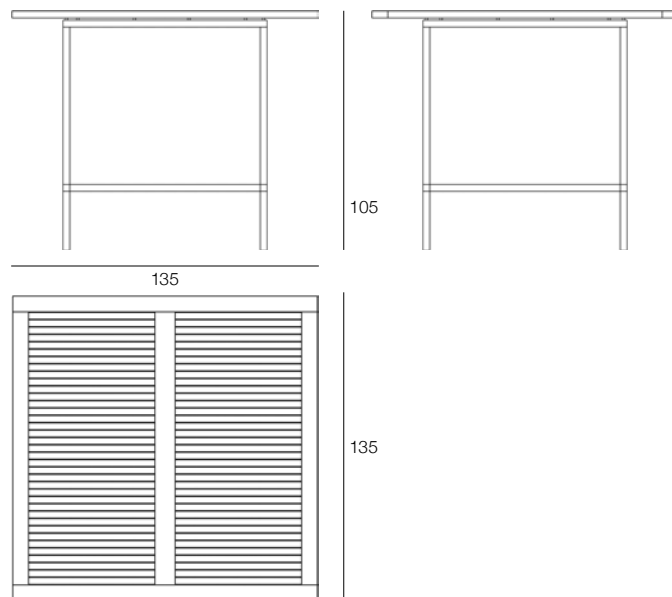

BONGO

design by CRS SILAT

I tavolini Bingo, Bango e Bongo sono intrecciati in vimine "Kubu Gray". Si tratta di fibra naturale che viene colorata con un metodo tradizionale e totalmente naturale che conferisce il tipico colore grigio, molto elegante, che ben si abbina con elementi moderni. Il materiale, resistente ma naturale, li rende perfetti per aree esterne coperte e possono essere usati anche come sgabelli o come comodini. I piani sono realizzati in massello di Teak a finitura naturale.

The Bingo Bango Bongo tables are made of woven "Kubu Gray" wicker: a natural fibre dyed using traditional, natural methods which gives its extremely elegant typical soft grey colour that seamlessly blends with modern elements. This natural but strong material makes the tables perfect for covered outdoor spaces and can be also used as stools or side tables. Fine Sanded finished solid Teak tops.

BINGO
BONG0469



BANGO
BONG0470



BONGO
BONG0471



BONG0469

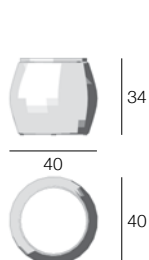

BONG0470

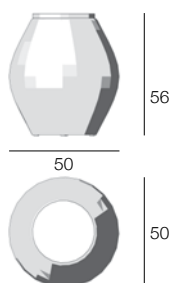

BONG0471

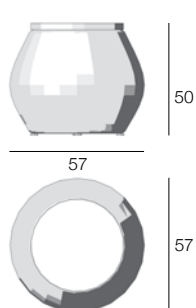

ZEF18203
ZEF18204
ZEF18205
BONG0470
BONG0471
TONG4502



CLASSICA

design by CRS SILAT

Interamente realizzata in legno massello di teak a finitura naturale con ferramenta in ottone. Design e materiali legati alla tradizione e grande varietà di misure e accessori disponibili. Le panchine, con o senza schienale, sono disponibili in differenti misure. Le panche di forma ottagonale sono pensate per circondare il tronco di un albero. Fanno parte della collezione Classica sedie e poltroncine pieghevoli, lettini e diversi tavoli estensibili disponibili in svariate forme e dimensioni, con piano rettangolare o rotondo.

Entirely made of Fine Sanded solid teak wood with brass hardware. Tradition-bound design and materials and a wide choice of sizes and accessories. The benches, with or without backrest, are available in various sizes, too. The octagonal benches are designed to encompass the tree trunk. Folding chairs and lounge chairs, sun loungers and various extendible tables available in different shapes and sizes with rectangular or round top are all part of the Classica collection.

CLAS0201



CLAS0202



CLAS0225



CLAS0301



CLAS0203



CLAS0201

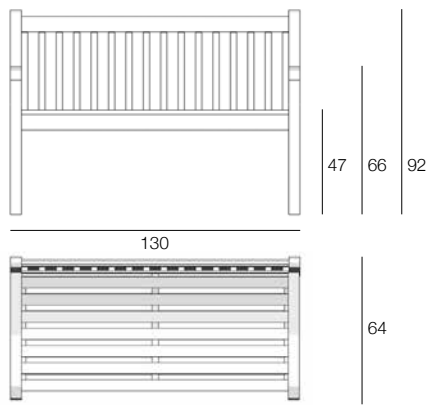

CLAS0301

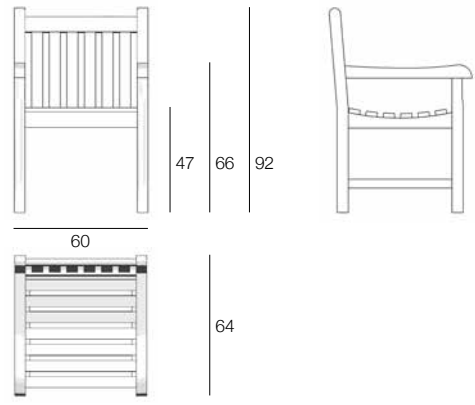

CLAS0202

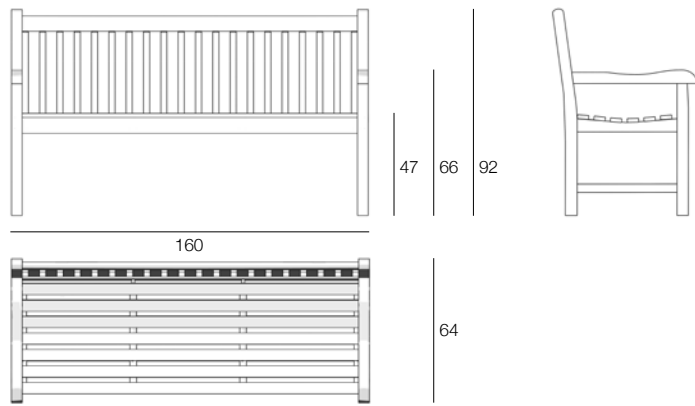

CLAS0225

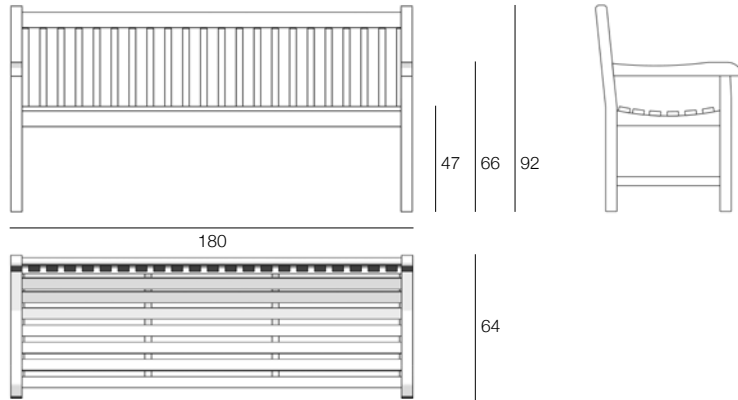

CLAS0203

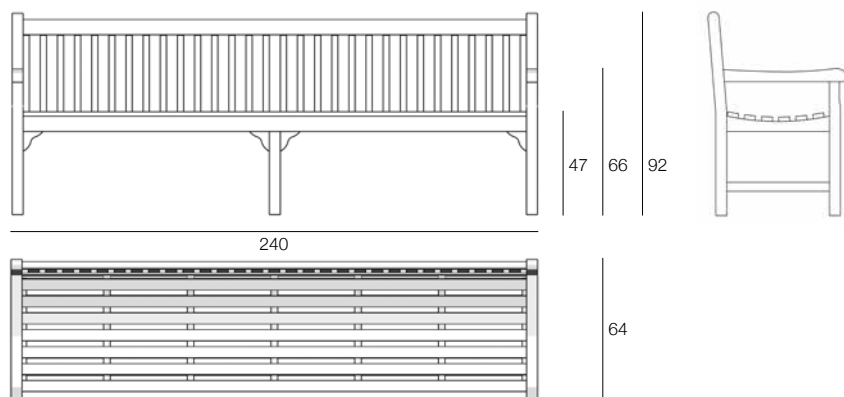

CLAS0218



CLAS0219



CLAS0204



CLAS0205



CLAS0304



CLAS0303



CLAS0218

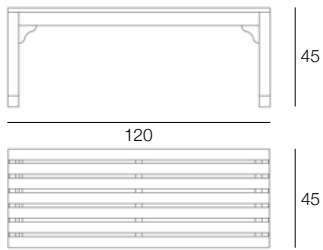

CLAS0219

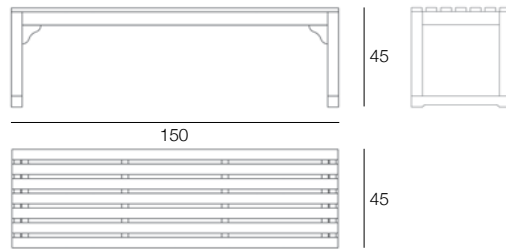

CLAS0204

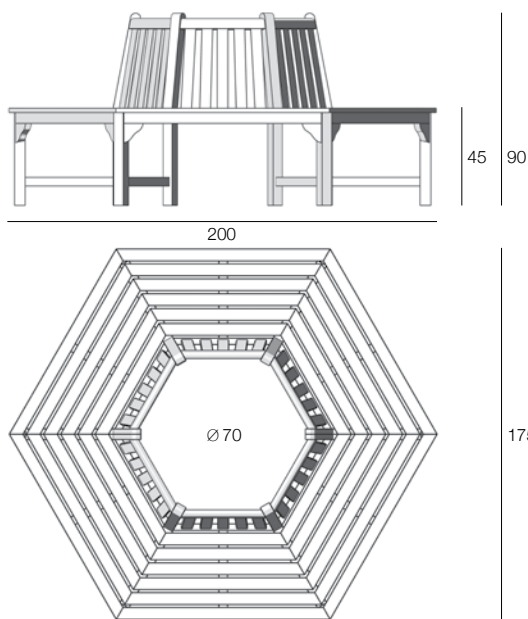

CLAS0205

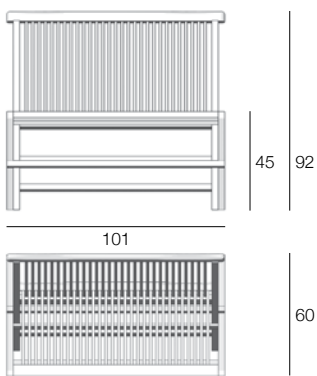

CLAS0304

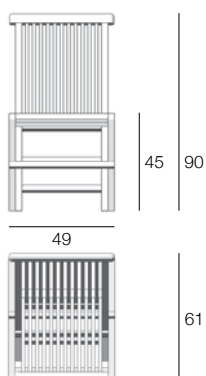

CLAS0303

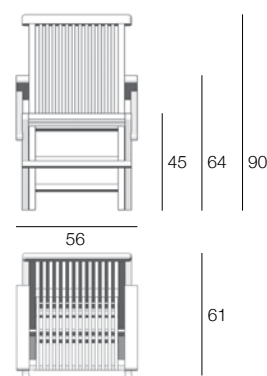

CLAS0424



CLAS0401



CLAS0402



CLAS0423



CLAS0404



CLAS0424

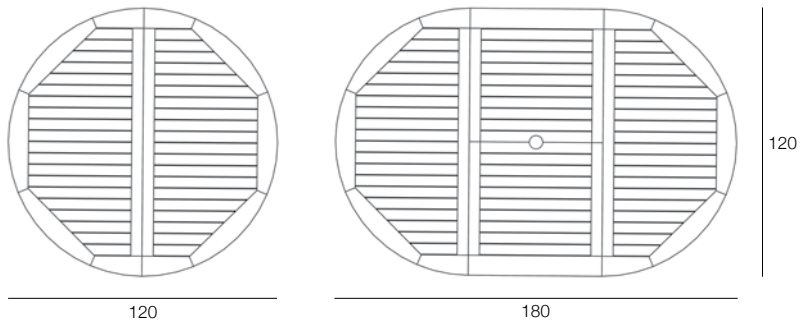

CLAS0401

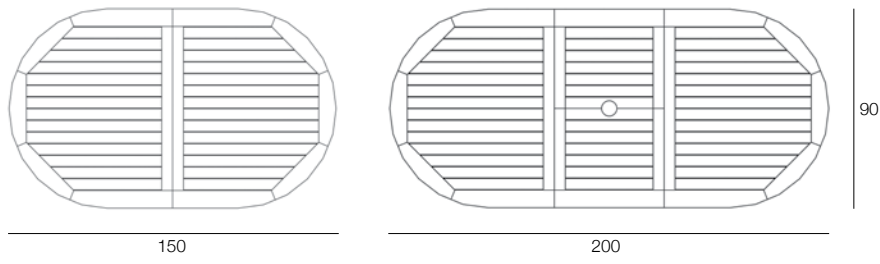

CLAS0402

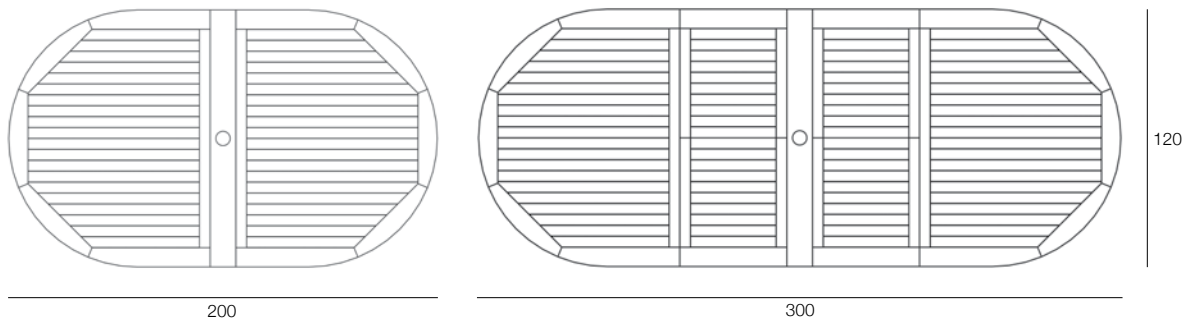

CLAS0423

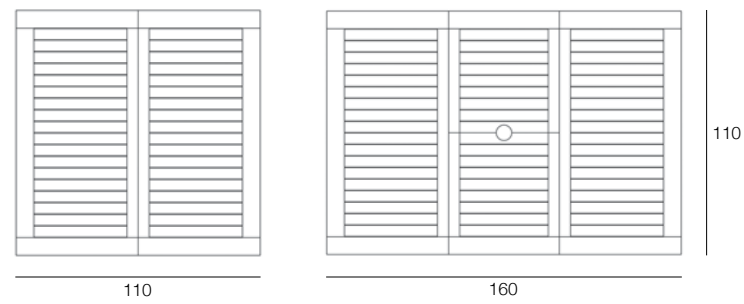

CLAS0404

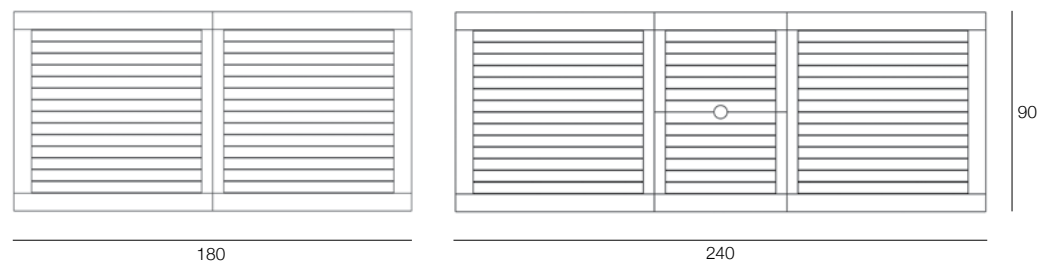

CLAS0447



CLAS0440



75

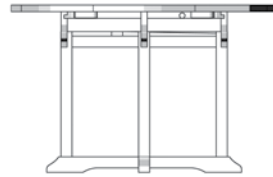

260

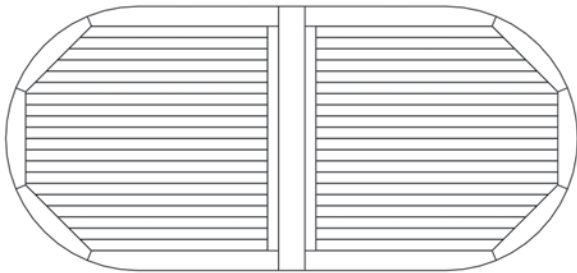

120

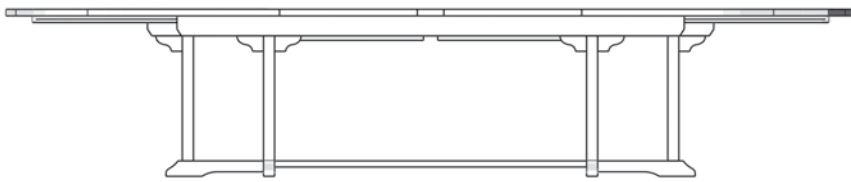

75

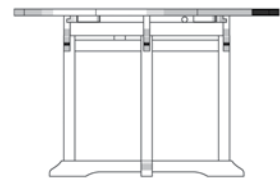

385

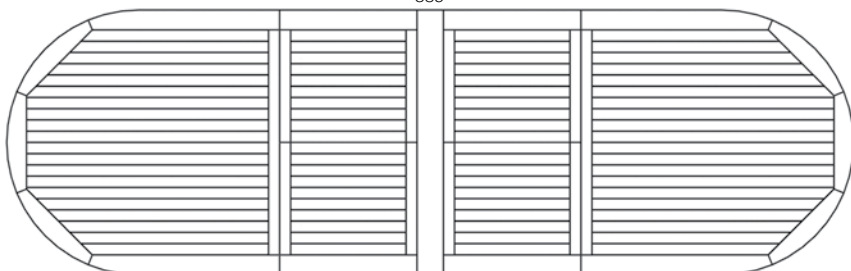

120



CLAS0447

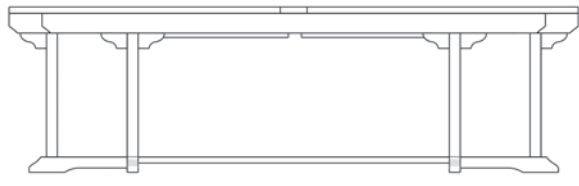

75

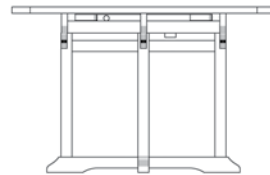

260



120

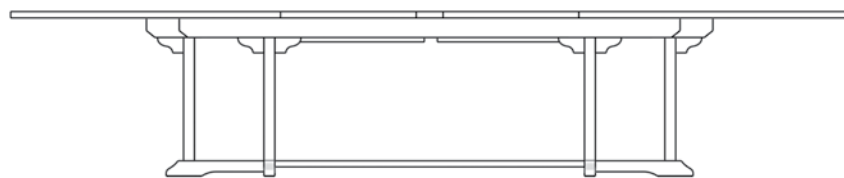

75

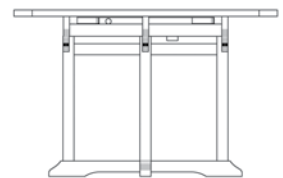

385

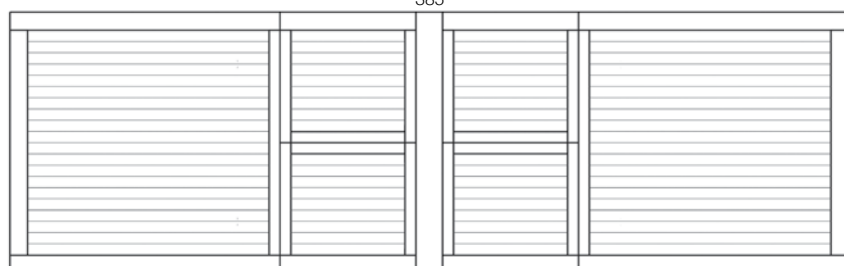

120

CLAS0503



CLAS0504



CLAS0508



CLAS0528



CLAS0521



CLAS0521



CLAS0503-CUS



CLAS0504-CUS



CLAS0521-CUS



CLAS0503

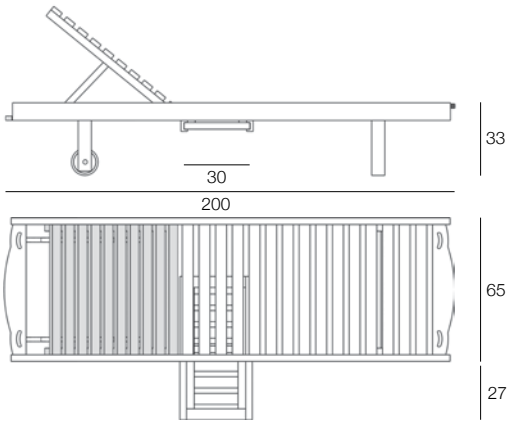

CLAS0504

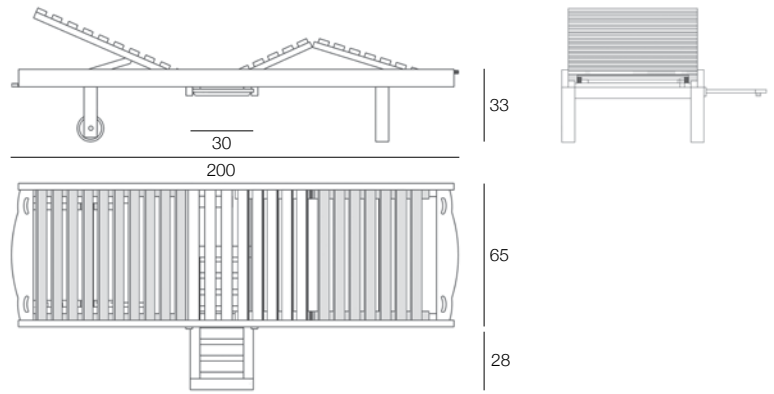

CLAS0508

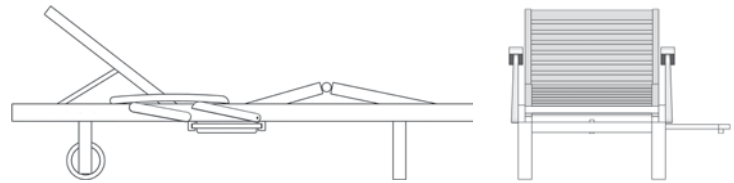
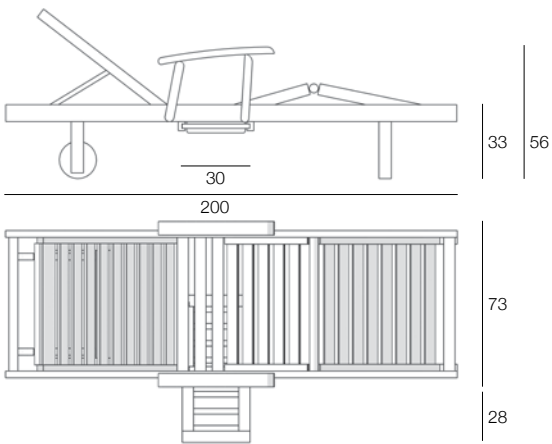

CLAS0521

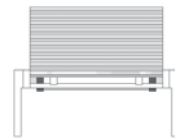
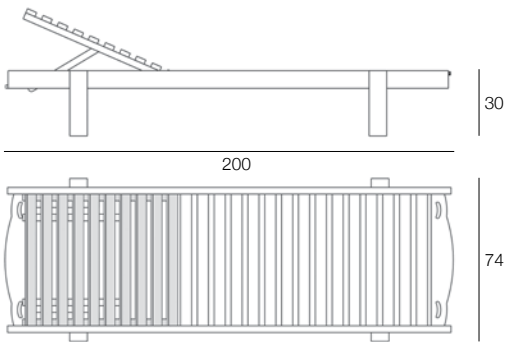

CLAS0528

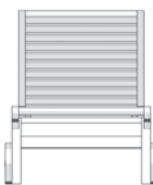
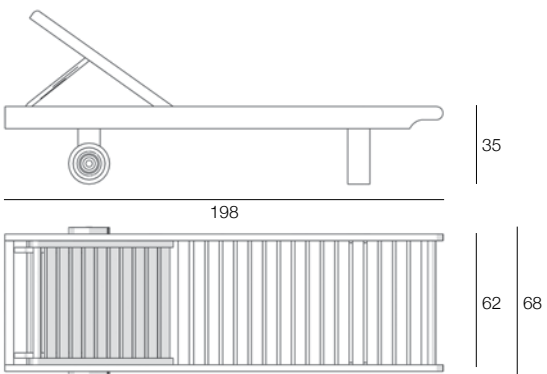

CLAS0864 + CLAS0864-CUS



CLAS0864

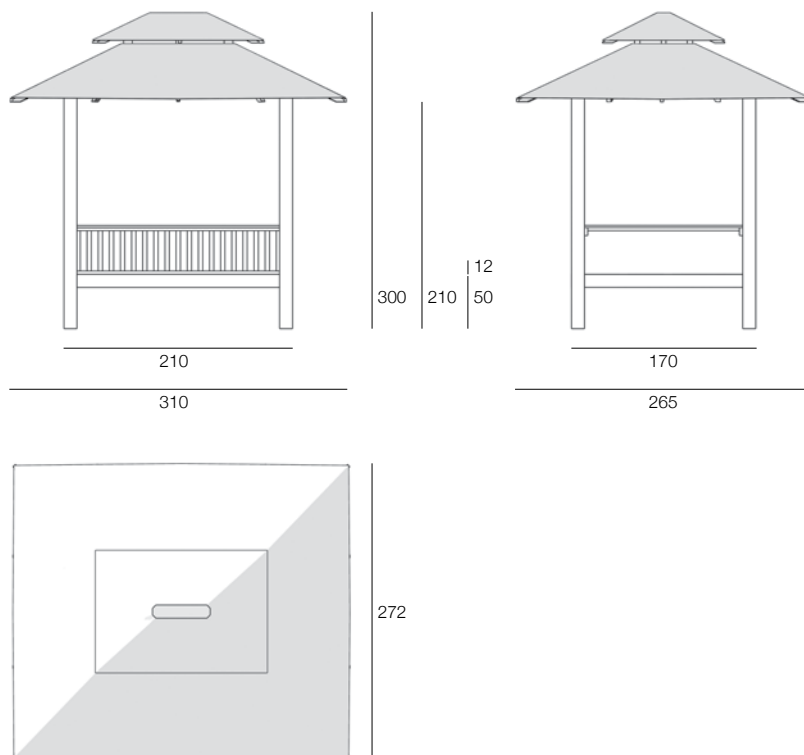



CLAS0503
CLAS0504
CLAS0508
CLAS0521
SAVA0458

DEHOR

design by CRS SILAT

Realizzata in legno di teak è caratterizzata da forme geometriche e decise, con poche curve, per un design essenziale ed efficace. Le sedie della collezione sono impilabili, e disponibili con o senza braccioli. I tavoli e tavolini hanno gambe smontabili fissate mediante ferramenta galvanizzata non a vista. Il Teak è proposto in finitura naturale.

Made of teak wood, with clean-cut geometrical shapes and minimalist curves for an essential, eye-catching design. The chairs of this collection are stackable and available with or without armrests. The tables and coffee tables feature removable legs secured with concealed galvanized hardware. The standard version comes in Fine Sanded finishing teakwood.

DEHO0344



DEHO0345



DEHO0344

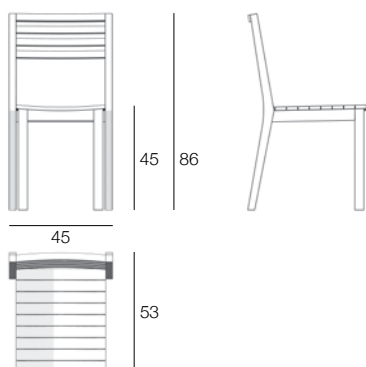

DEHO0345

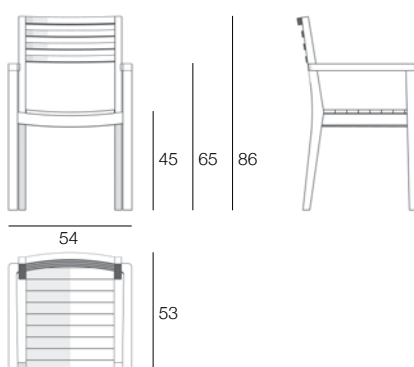

DEH00344
DEH00345
DEH00418



DEHO0418



DEHO0419



DEHO0420



DEHO0411



DEHO0441



DEHO0422



DEHO0418

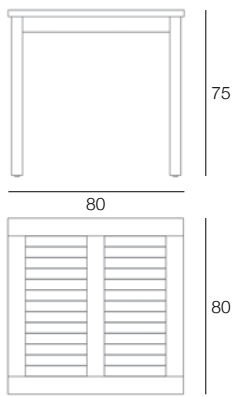

DEHO0419

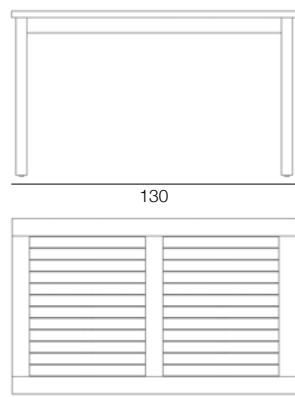

DEHO0420

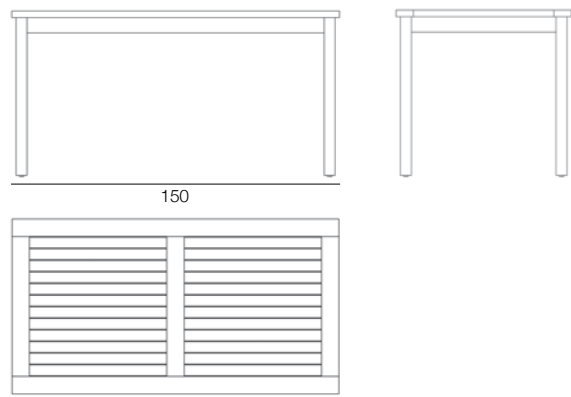

DEHO0411

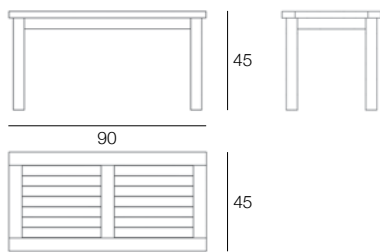

DEHO0441

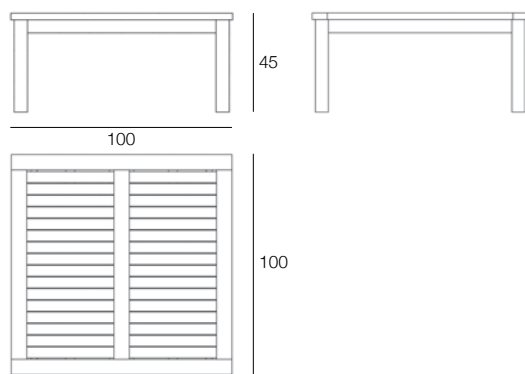

DEHO0422

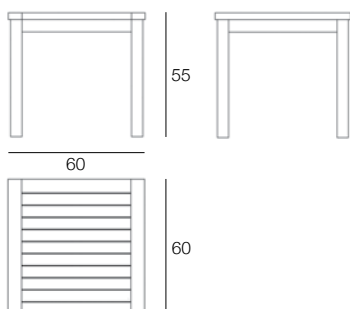

EMILY

design by CRS SILAT

Gambe e struttura in legno massello di Teak con finitura protettiva e piedini antigraffio in Teflon. Intreccio in fibra sintetica Core rotonda senza pigmentazione.

Frame, legs and arms are made of weather-resistant Teak wood with a layer of protective finishing and non-scratch Teflon glides. Woven with Core transparent wicker.

EMIL4322



EMIL0459



EMIL4322

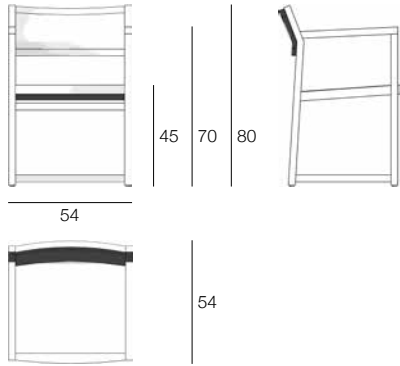

EMILO459

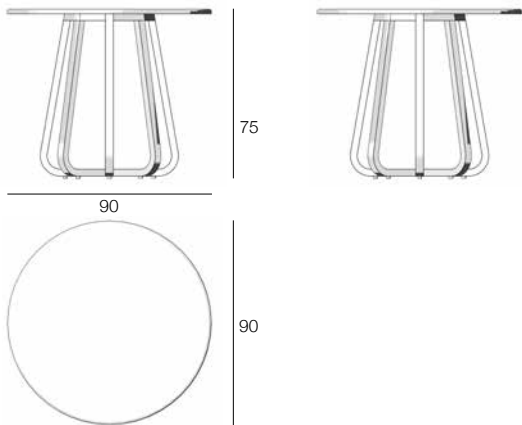

FIJI

design by CRS SILAT

Struttura in legno massello di Teak sulla quale viene intrecciata una fibra estrusa di polietilene ad alta densità. Piedini antigraffio in Teflon. Le curve minimali, classiche e pulite di questa collezione la rendono adatta a caratterizzare con stile ogni zona esterna. Proposto in Teak finitura naturale, fibra sintetica colore Ice White.

Fiji Collection has a solid Teak structure, hand-woven with Extruded High Density Polyethylene. Non-scratch Teflon glides. The minimalist classic and clean curves of this collection make it suitable to characterize every outdoor area in style. Standard finishes are Fine Sanded teak wood and Ice White synthetic fibre.

FIJI4203 + FIJI4203-CUS



FIJI4304 + FIJI4304-CUS



FIJI4305 + FIJI4305-CUS



FIJI4407



FIJI4408



FIJI4503



FIJI4203

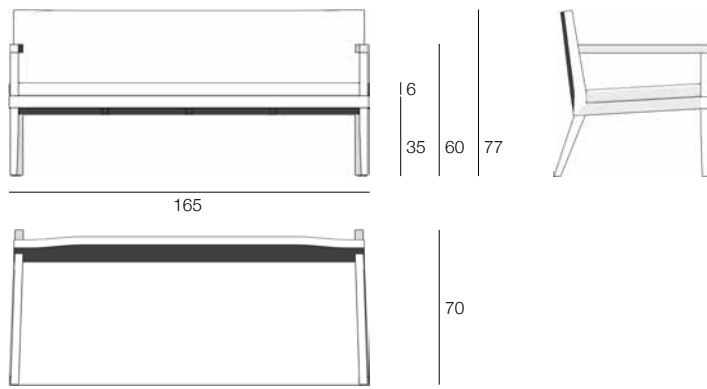

FIJI4304

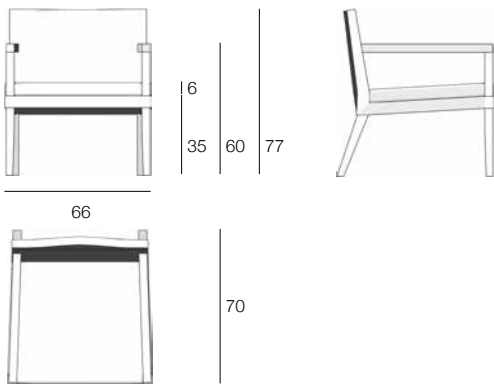

FIJI4305

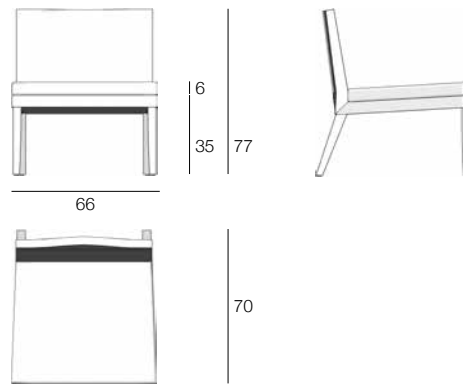

FIJI4407

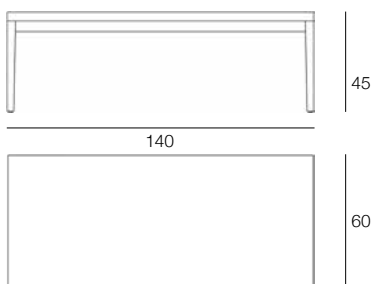

FIJI4408

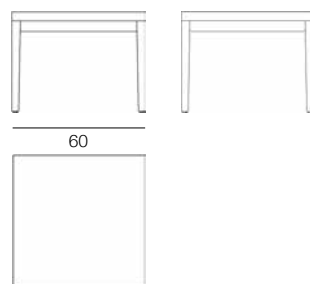

FIJI 4503

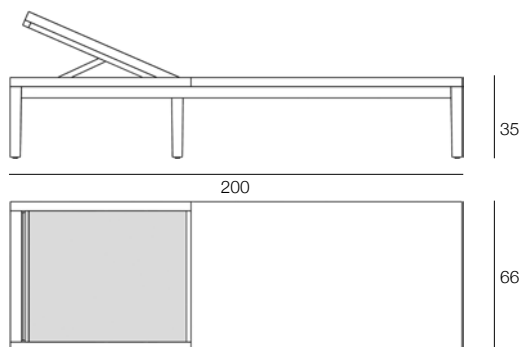

FIJI4306



FIJI4307



FIJI4318



FIJI4405



FIJI4406



FIJI4306

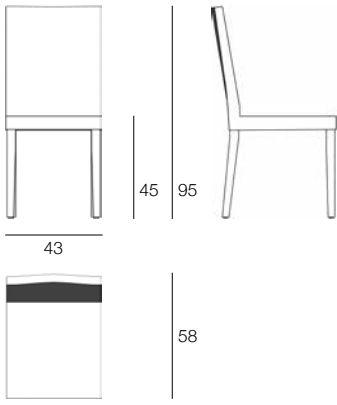

FIJI4307

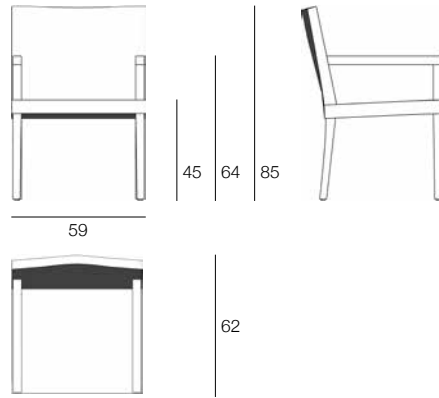

FIJI4318

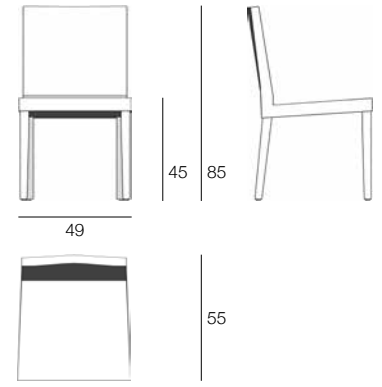

FIJI4405

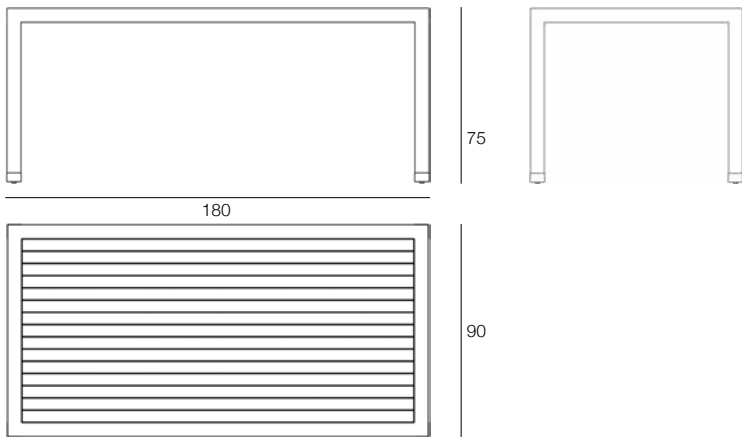

FIJI4406

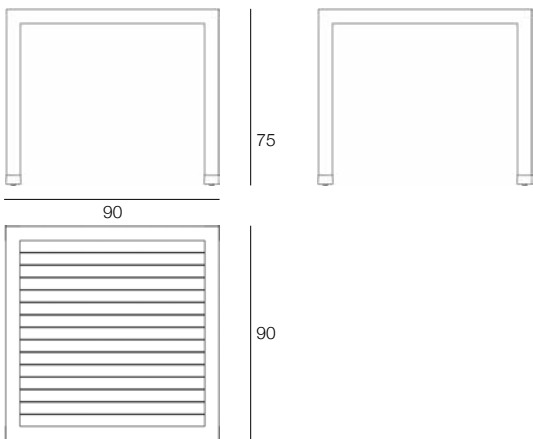

FOSSIL

design by TIME

Il legno fossile od 'opale xiloide' è il risultato di un tronco completamente mutato tramite processo di mineralizzazione, nel quale tutte le parti organiche vengono sostituite da minerali, per lo più silicati come il quarzo, che ne hanno permesso la conservazione attraverso diverse ere geologiche mantenendo la tipica struttura fibrosa del legno, i caratteristici anelli concentrici di accrescimento e persino le tracce dei tarli che vivevano un tempo nel tronco. Ogni pezzo è ovviamente unico, ma può essere lucidato o grezzo, con corteccia o senza e tagliato della dimensione richiesta dal cliente.

Petrified wood is the name given to fossilized remains of terrestrial vegetation. It is the result of a tree having completely transitioned to stone by the process of permineralization. All the organic materials have been replaced with minerals mostly silicates such as quartz, allowing them to be preserved along the different geological eras while retaining the original structure of the stem tissue as well as the concentric rings and traces of the worms, once living in the trunk. Every single piece is unique, but we supply it with bark or polished and cut on the customer's requested size.

FOSS0462





FOSS0462

GEORGETOWN

design by CRS SILAT

Struttura costituita da componenti arrotondate in legno di Teak e caratterizzata dalla finitura a Olio e Cera che conferisce il tipico color miele. Le panche e poltroncine presentano schienali curvi, le cui sinuose forme proseguono nei braccioli. Il divano, con schienale alto è completato da cuscini in poliuretano rivestiti in tessuto acrilico sfoderabile e con gommapiuma protetta da fodera interna, può essere completato da poggiatesta modulari che lo trasformano in un ampio e comodo letto da giorno o in una *chaise longue*. Le poltroncine possono essere arricchite da un cuscino che completa lo schienale e ne segue la curvatura. I tavoli sono disponibili con piani in vetro o in Teak di diversa forma. La collezione comprende anche dei lettini per esterno e ampi vassoi di forma ottagonale, disponibili in due dimensioni.

Frame of rounded teakwood components with Oil & Wax finish which endows them with their typical honey colour. The sinuous design of the rounded backrests of the benches and lounge chairs is echoed in the armrests. The high-back sofa, supplemented by polyurethane cushions lined with removable acrylic fabric and with foam protected by an internal lining, can be completed with modular footrests to convert it into a large, comfortable daybed or chaise-longue. The dining armchairs can be fitted with a cushion that completes the backrest and follows its curve. The tables are available with differently-shaped glass or Teak wood tops. The collection also includes sun loungers and large octagonal trays available in two sizes.

GEOR0206



GEOR0306



GEOR0412



GEOR0206

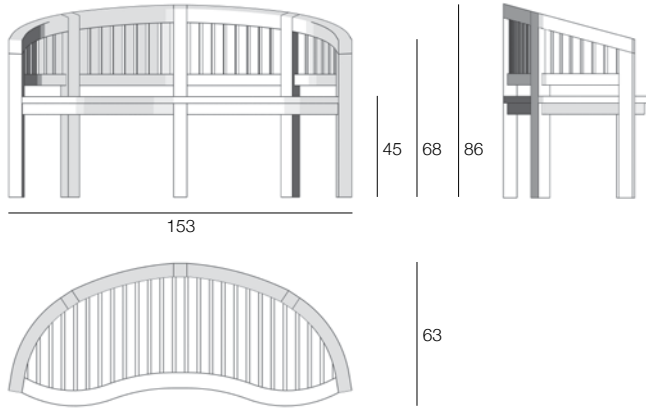

GEOR0306

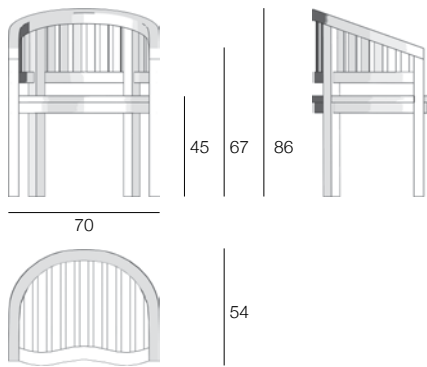

GEOR0412

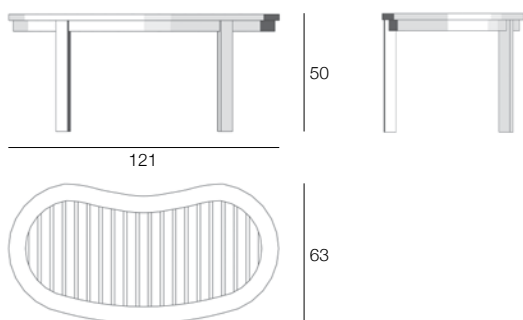

GEOR0231 + GEOR0231-CUS



GEOR0232



GEOR0232 + GEOR0232-CUS



GEOR0233



GEOR0233 + GEOR0233-CUS



1 X GEOR0231 + GEOR0231-CUS
1 X GEOR0233 + GEOR0233-CUS



1 X GEOR0231 + GEOR0231-CUS
1 X GEOR0232 + GEOR0232-CUS

GEOR0231

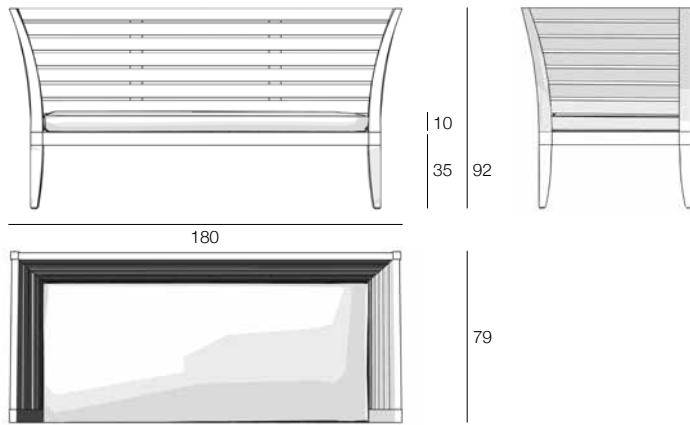

GEOR0232

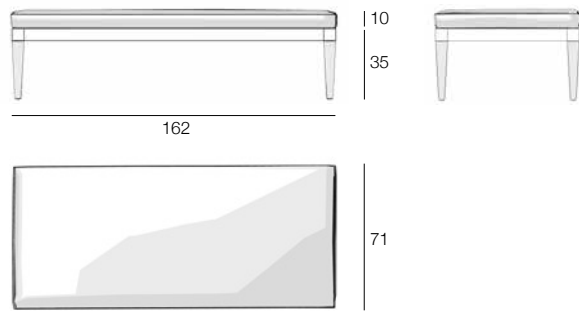

GEOR0233

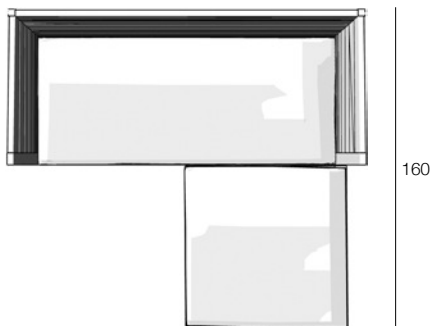
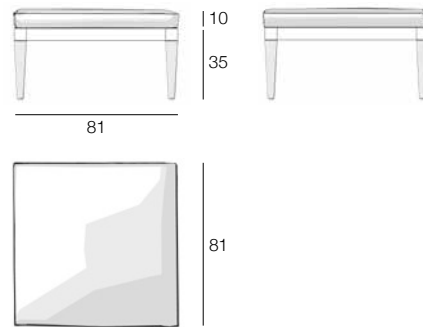

1 X GEOR0231
1 X GEOR0233

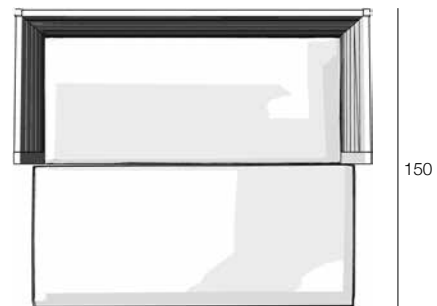

1 X GEOR0231
1 X GEOR0232

GEOR0349



GEOR0349 + GEOR0349-CUS



GEOR0483



GEOR0708+K01



GEOR0708+K02



GEOR0450



GEOR0509



GEOR0509 + GEOR0509-CUS



GEOR0855



GEOR0856



GEOR0349

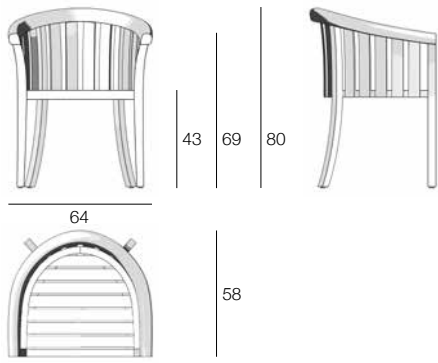

GEOR0483

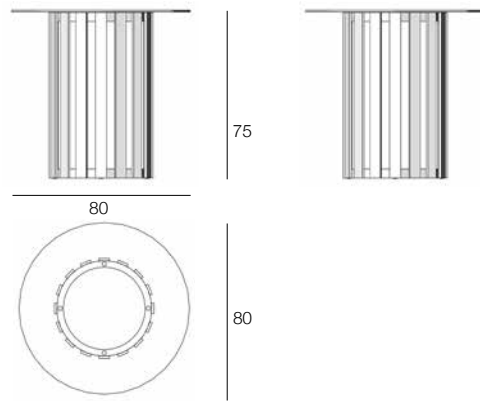

GEOR0708 + K01

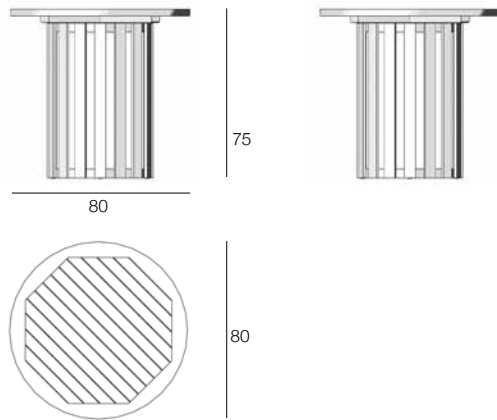

GEOR0708 + K02

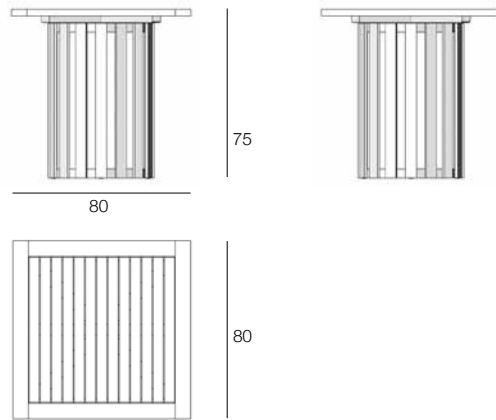

GEOR0450

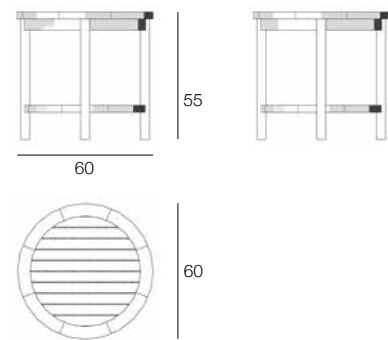

GEOR0509

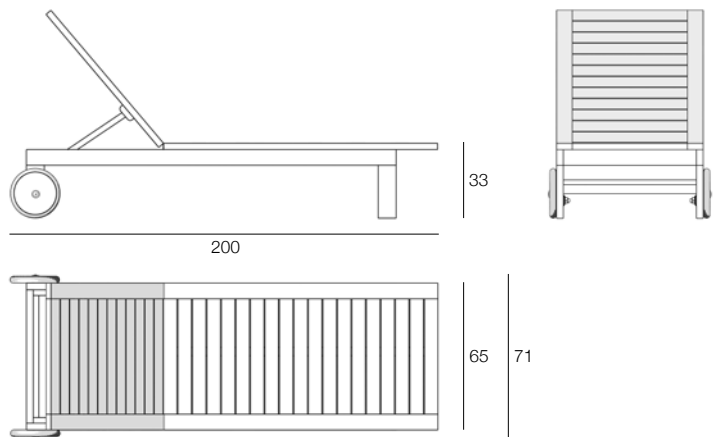

GEOR0855

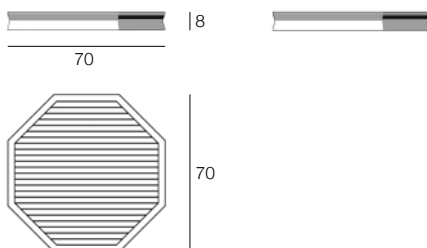

GEOR0856

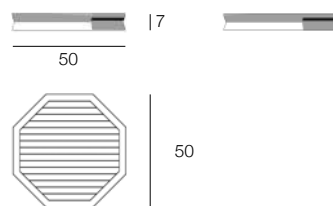

GIAVA

design by CRS SILAT

In legno di Teak a finitura Olio e Cera dal caldo color miele. Dal design raffinato, reso unico dallo schienale decorato tramite i motivi creati con i listelli di Teak e dalla lavorazione tornita delle gambe.

Warm honey-coloured Oil & Wax finished Teak wood with an elegant design, becoming so unique thanks to the backrest decorated with Teak slat motifs and the elegantly-turned legs.

GIAV0244

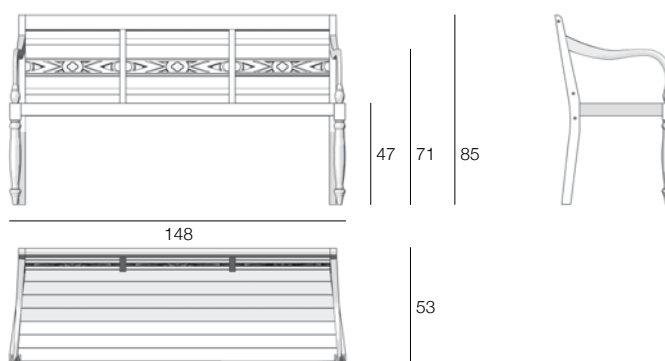

GIAV0244





GIAV0244

GIPSY

design by CRS SILAT

Il design anni sessanta e la grande eleganza formale sono i punti di forza di questa collezione dall'estrema comodità. Sedie con gambe in legno massello di Teak e piedini in Teflon. Struttura in tubolare di alluminio rivestito con polyrattan sintetico intrecciato a mano. Intreccio realizzato con fibra a sezione rotonda Core in colore White Wash. Tavoli con struttura e piano in massello di Teak e base con intreccio in HDPE Peel 6mm. Il Teak è proposto in finitura naturale.

Its Sixties design and great formal elegance are the main assets of this extremely comfortable collection. Chairs with unfinished solid Teak wood legs and Teflon feet. Inner aluminum frame construction of the upper part covered with hand-woven Core PVC fiber. Tables with top and frames in solid Teak and base woven with 6mm Peel HDPE fiber. Standard finishes are Fine Sanded for the Teak wood and White Wash for the synthetic fibre.

GIPS4321



GIPS4324



GIPS4704+K01



GIPS4704+K02



GIPS4321

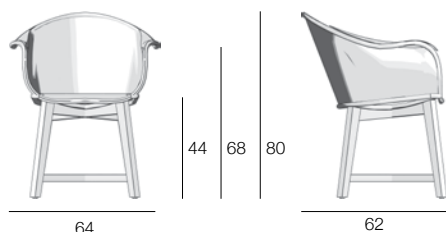

GIPS4324

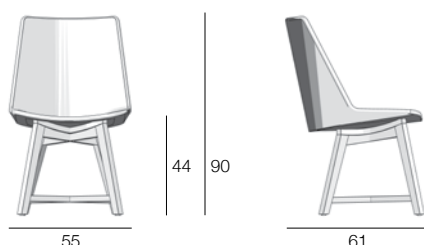

GIPS4704+K01

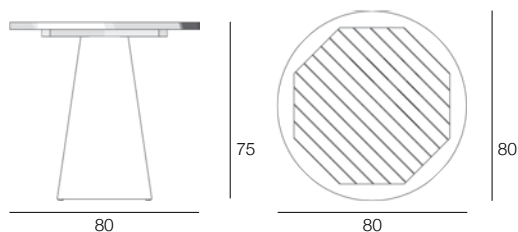

GIPS4704+K02

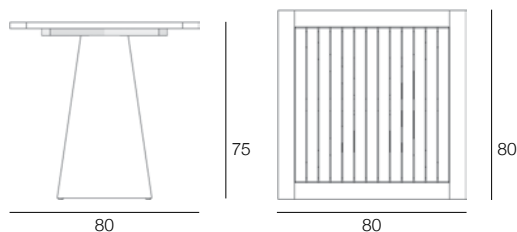



GIPS4321
GIPS4704+K01



GIPS0460
GIPS0461
GIPS4323

GIPS4323



GIPS4323

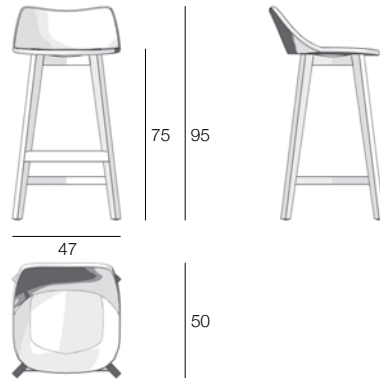

GIPS0461



GIPS0461

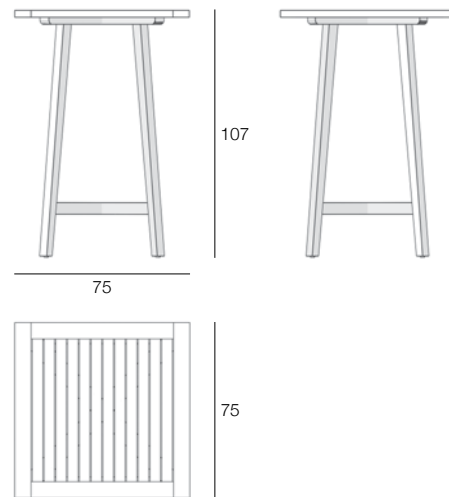

GIPS0460



GIPS0460

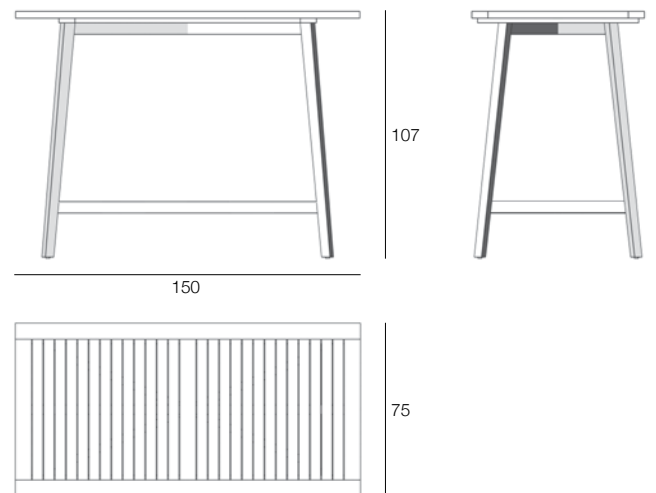

INFINITY

design by FEDERICA FERRARA

Struttura in acciaio inox a finitura satinata. Sedute e schienali rivestiti con polyrattan sintetico intrecciato a mano. Piani dei tavoli in massello di Teak a finitura naturale.

Stainless steel structure with satin finish. Seats and backs covered with Core woven PVC fiber. Fine Sanded finish Teak wood table surfaces.

INFI5311



INFI5311

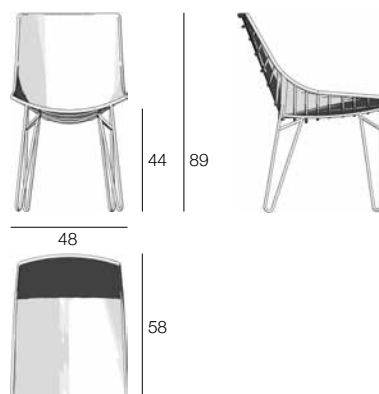

INFI5402



INFI5402

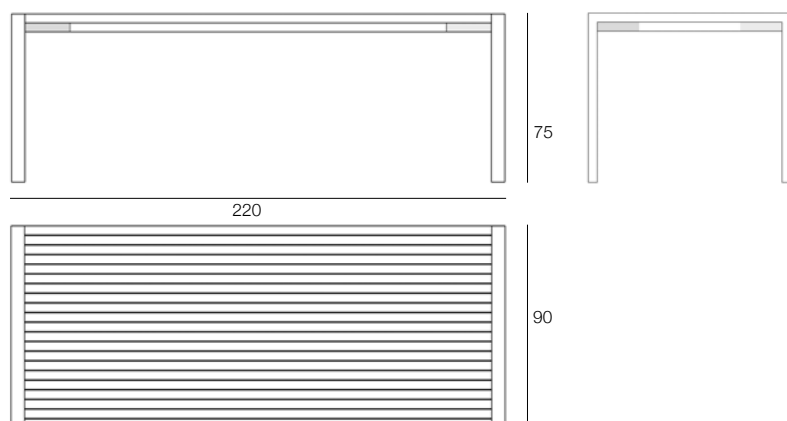



JUNIOR

design by CRS SILAT

Le sedie e le panche della linea Junior sono realizzate in legno di Teak con tutta la cura e la ricercatezza delle collezioni "per i grandi". Ferramenta in ottone e finitura del legno Olio e Cera. Rattan naturale intrecciato su struttura in legno per la versione 'mini' della sedia Porter, adatta per esterni coperti.

The chairs and the benches of the Junior line are crafted in Teak wood with the same care and attention dedicated to the collections for "grown-ups". Brass hardware and Oil & Wax finish wood. Natural rattan woven on wooden structure for the "mini" version of the Porter chair, suggested for covered spaces.

JUNIO608



JUNIO601



JUNIO604



JUNIO606



JUNIO602



JUNIO605



JUNI0608

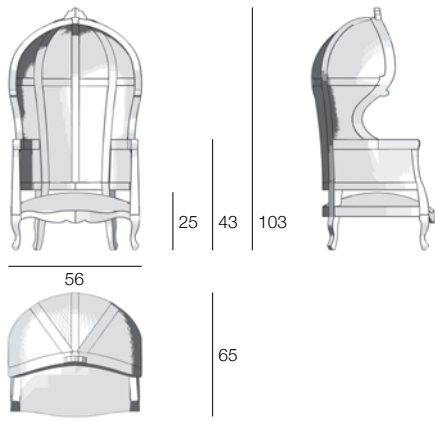

JUNI0601

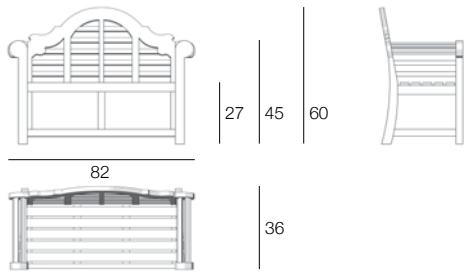

JUNI0604

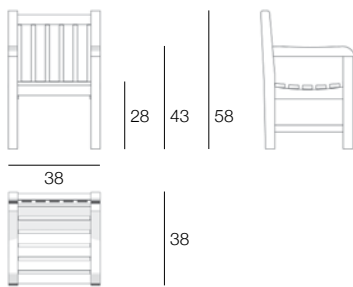

JUNI0606

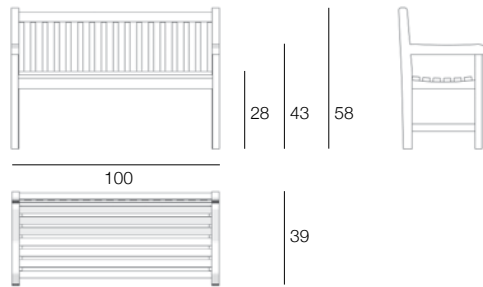

JUNI0602

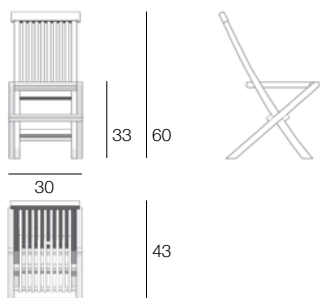

JUNI0605

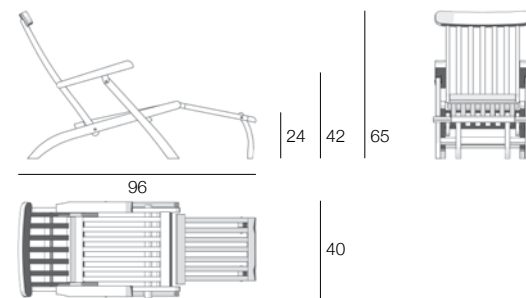

LOGIKA

design by CRS SILAT

Struttura in acciaio inox a finitura satinata. Sedute e schienali in filo di poliestere rivestito in PVC tessuto e saldato ad alta frequenza. Ripiegata occupa pochi centimetri di spazio. Proposta in Batyline® nero.

Stainless steel structure with satin finish. Seats and seatbacks in woven and high frequency welded polyester PVC covered wire. When folded, it takes up only a couple of centimeters. Standard finishing is black Batyline®.

LOGI5310

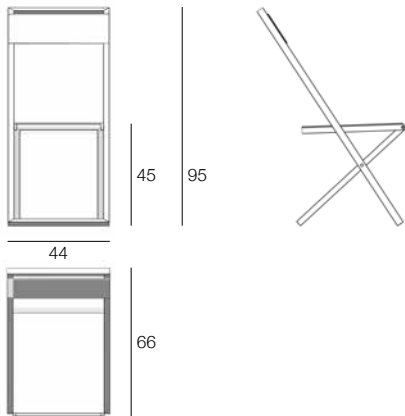

LOGI5310



LOGI5310



LUI & LEI

design by FEDERICA FERRARA

Struttura in tubolare di alluminio trattato con bagno di pulitura e verniciato a polveri. Sedute e schienali delle sedie e dei lettini in Batyline® saldato ad alta frequenza. Per divani e poltrone è necessario l'utilizzo di un cuscino per seduta e schienale, in poliuretano espanso a densità differenziata o a celle aperte. Piani dei tavoli in massello di Teak o vetro satinato. 'Lui' di vocazione maschile ha una finitura in elegante nero satinato opaco mentre 'Lei' in sciccoso bianco lucido. Due finiture diverse nel colore e al tatto che ben si abbinano con il legno di Teak in finitura naturale, con il vetro satinato ed il tessuto tecnico Ferrari utilizzato nei diversi modelli come proposta da catalogo.

Cleansed and powder coated tubular aluminium structure. Chair and sunbed seats and backs in high frequency welded Batyline®. Sofas and armchairs require the use of a cushion for the seat and back, made of low/high density polyurethane foam or flow-through foam. Teak wood or frosted glass table surfaces. 'Lui', Italian word for Him, has a masculine feel, with elegant black matte satin finishes, while 'Lei', meaning Her, articles are in a chic semi glossy white. Two finishes different in colour and texture perfectly matching with the Fine Sanded Teak wood, the frosted glass and the Ferrari technical fabric proposed in Black as standard version for Lui items and in white for Lei items.

LUIE0301_FSDB



LUIE0401_FSDB



LUIE0201_DB + LUIE0201-CUS



LUIE0403_FSDB



LUIE0404_FSDB



LUIE0301

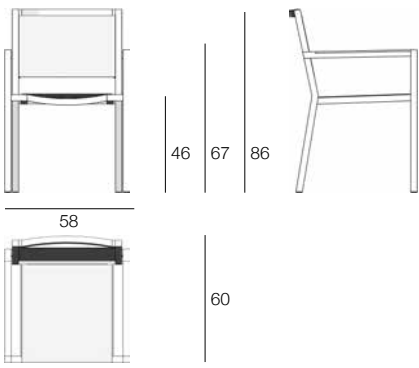

LUIE0531

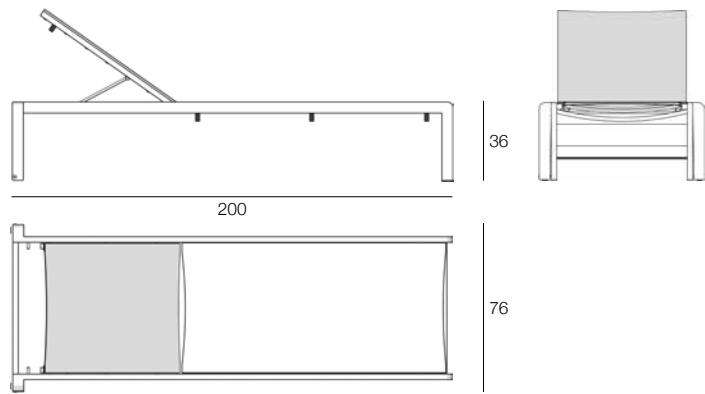

LUIE0401

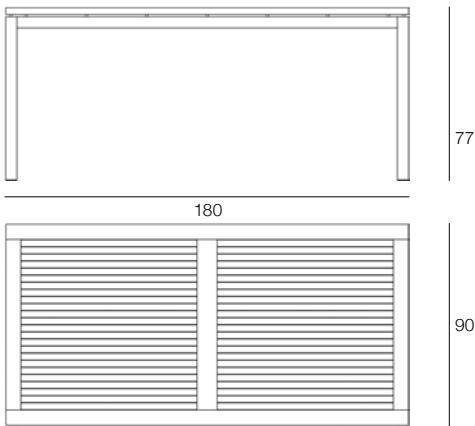

LUIE0402

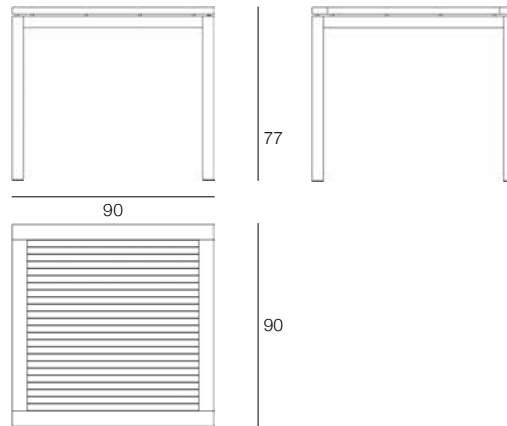

LUIE0201

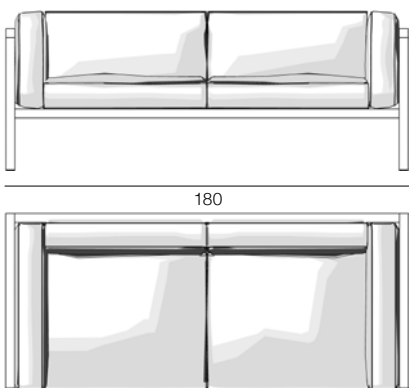

LUIE0202

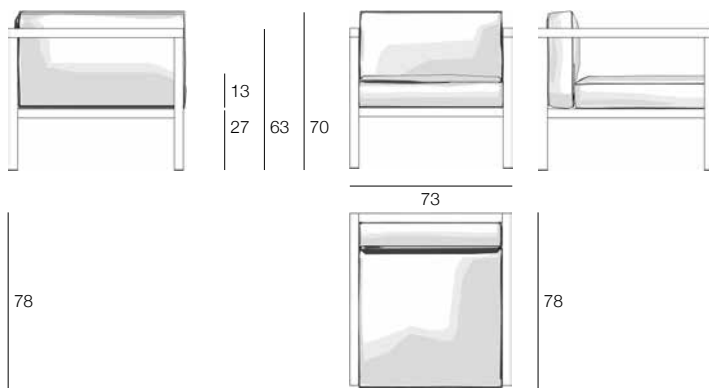

LUIE0403

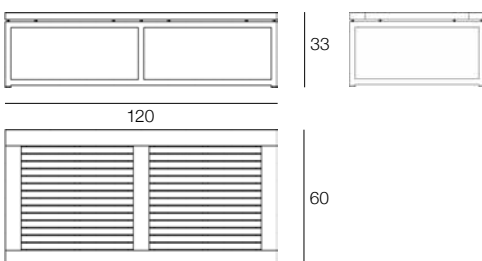

LUIE0404

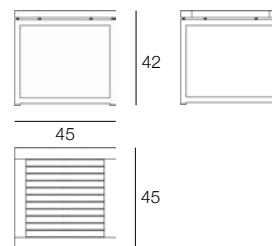

LUIE0531_SW



LUIE0301_FSSW



LUIE0401_FSSW



LUIE0402_FSSW



LUIE0201_SW + LUIE0201-CUS



LUIE0202_SW + LUIE0202-CUS



LUIE403_FSSW



LUIE404_FSSW



LUIE0202
TILT2501



MACAO

design by CRS SILAT

Struttura in Teak a finitura naturale, ferramenta in ottone cromato, acciaio e alluminio. Sedute e schienali in tessuto tecnico proposto in colore nero. Le sedute sono pieghevoli o impilabili. I lettini da sole sono disponibili smontabili oppure impilabili. Quelli smontabili sono dotati di ruote in Teflon con cuscinetti a sfera, ideali per il bordo piscina. Personalizzazioni per posizionamento in spiaggia da effettuarsi su richiesta. I tavoli a piantana o con quattro gambe smontabili sono disponibili in diverse forme e misure. Il tavolo rettangolare ha ferramenta in ottone, gli altri tavoli sono dotati di viti in acciaio per il fissaggio del piano.

MACA0309



Teakwood frame with Fine Sanded finish, chromed brass, steel and aluminium hardware. Seats and backrests made of woven and high frequency welded PVC coated polyester proposed in black. The seats can be folded or stacked. The sun loungers are available in a demountable or stackable version. Demountable sun beds are fitted with Teflon wheels with bearings, ideal for pool side use. Customisations for positioning on beach available on request. The tables with pedestal or four removable legs are available in various shapes and sizes. The rectangular table features brass hardware while the other tables are fitted with steel screws for top fastening.

MACA0340

MACA0341



MACA0342

MACA0347



MACA0309

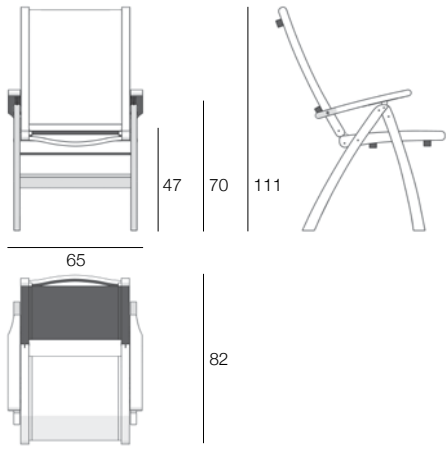

MACA0340

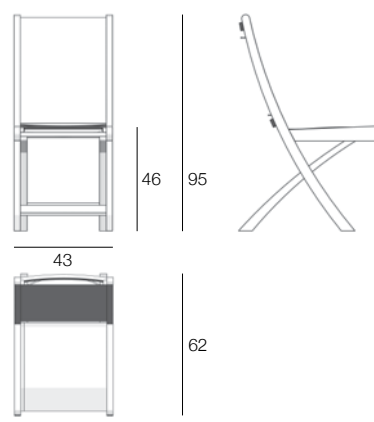

MACA0341

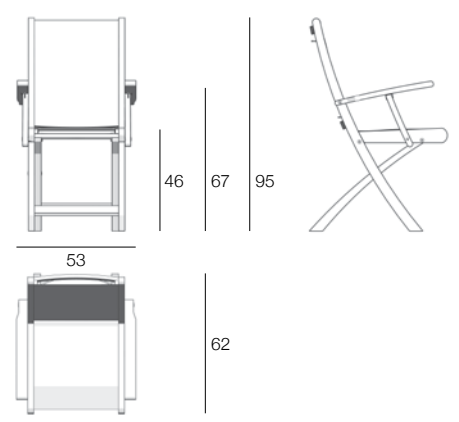

MACA0342

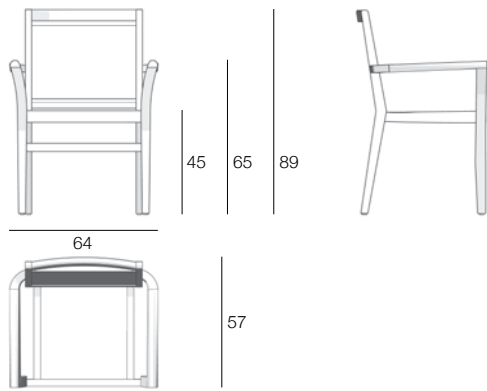

MACA0347

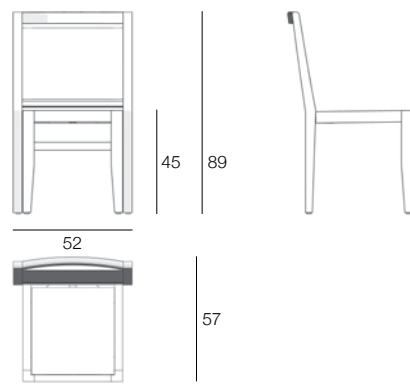

MACA0309



MACA0403



MACA0405



MACA0410



MACA0468



MACA0438



MACA0439



MACA0403

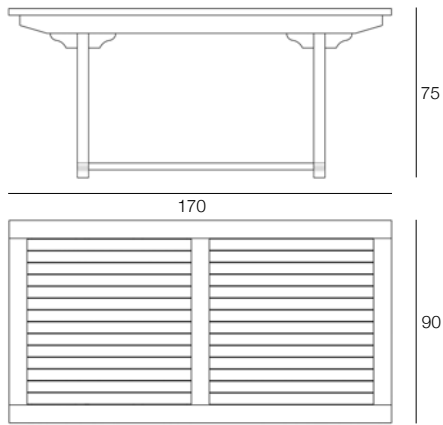

MACA0405

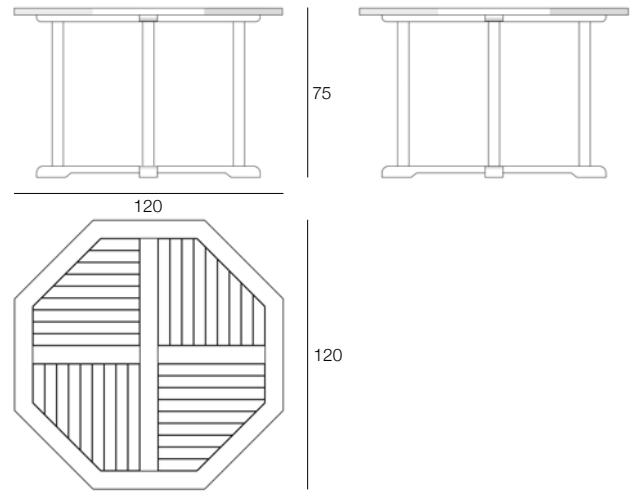

MACA0410

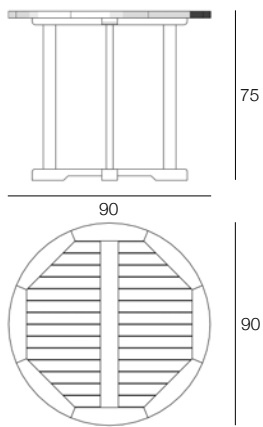

MACA0468

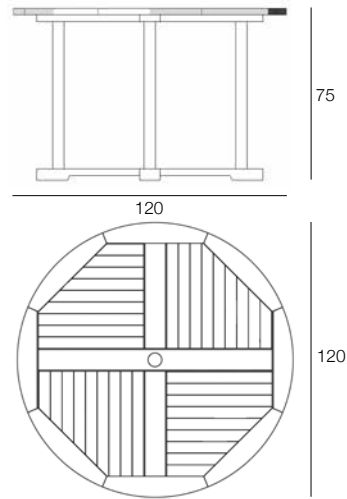

MACA0438

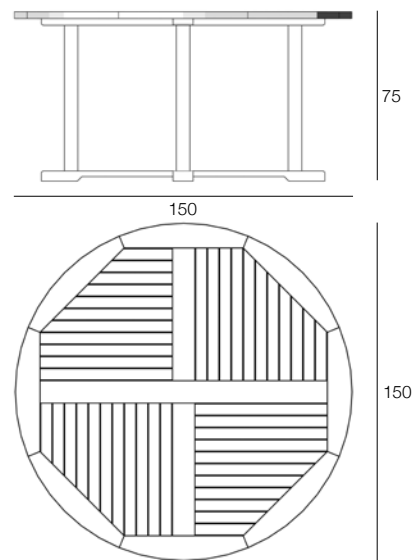

MACA0439

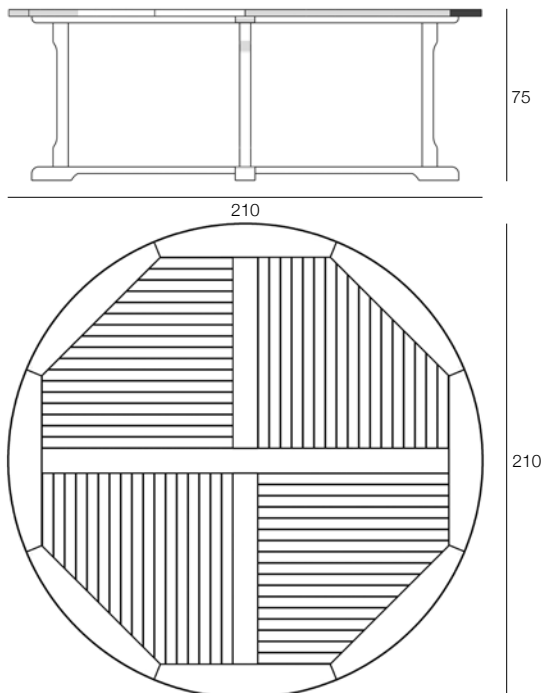

MACA0702+K01



MACA0702+K02



MACA0703+K01



MACA0510



MACA0527



MACA0527



MACA0702+K01

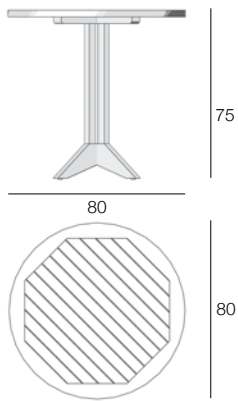

MACA0702+K02

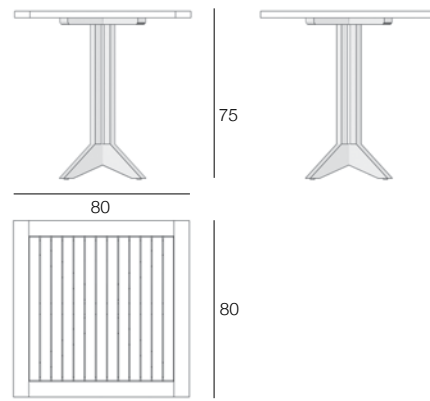

MACA0703 + K01

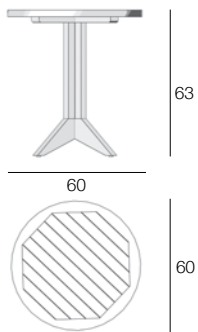

MACA0510

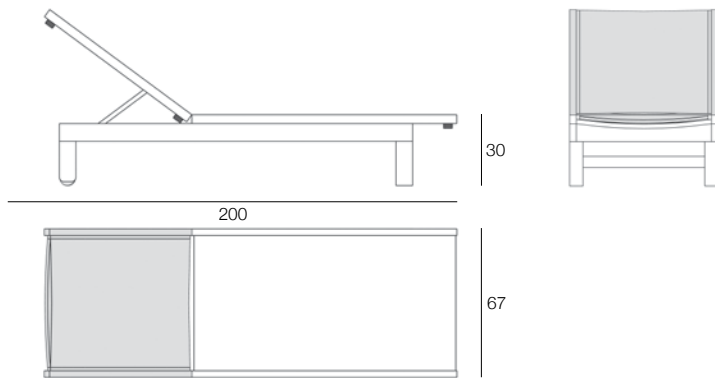

MACA0527

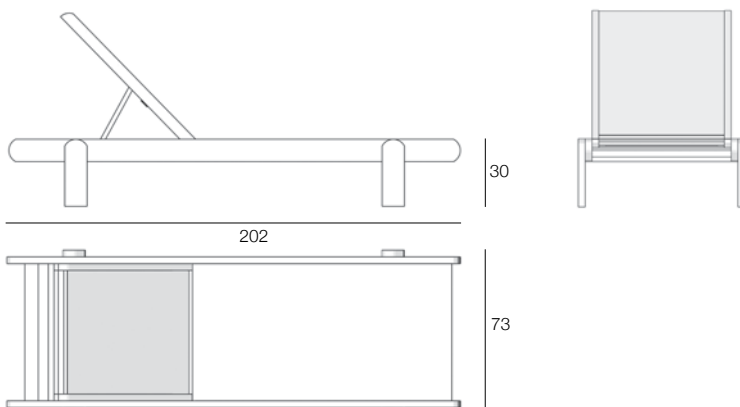

MANHATTAN

design A3DIMENSIONI

Struttura in acciaio inox a finitura satinata. Cuscineria in poliuretano a celle aperte permeabile all'aria e all'acqua, garantisce tempi brevi di asciugatura e abbina elevate prestazioni tecniche a doti di comfort ed eleganza. Struttura degli schienali totalmente non a vista.

Stainless steel structure with satin finish. Cushions in flow-through foam permeable to water and to air. It dries quickly and it combines high technical performances with comfort and elegance. Completely hidden backseats frame.

MANH8208



MANH8209



MANH8206



MANH8206



MANH8207



MANH8206

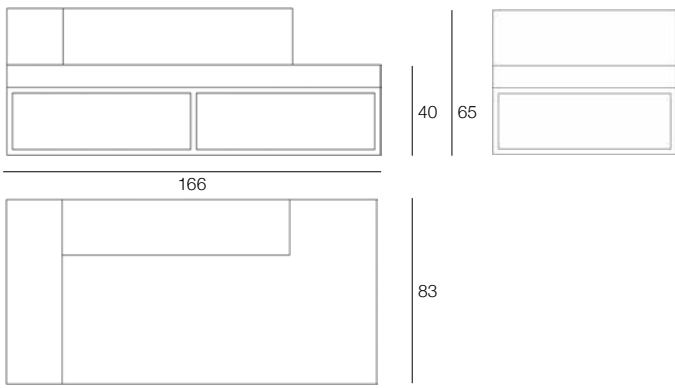

MANH8208

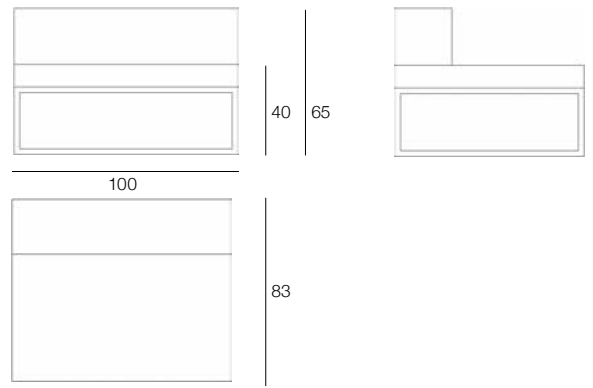

MANH8207

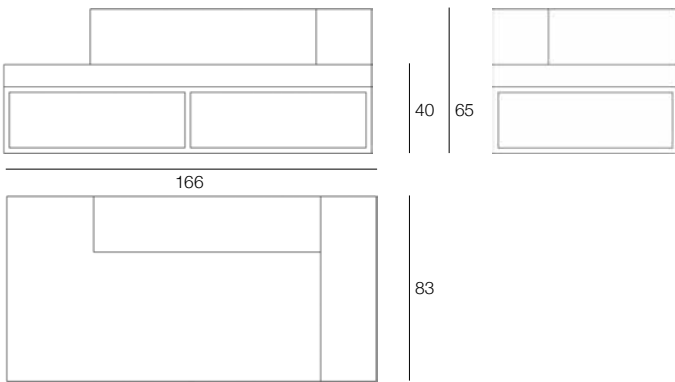

MANH8209

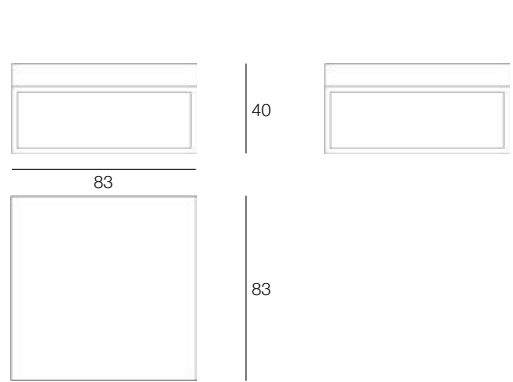

MANH8210

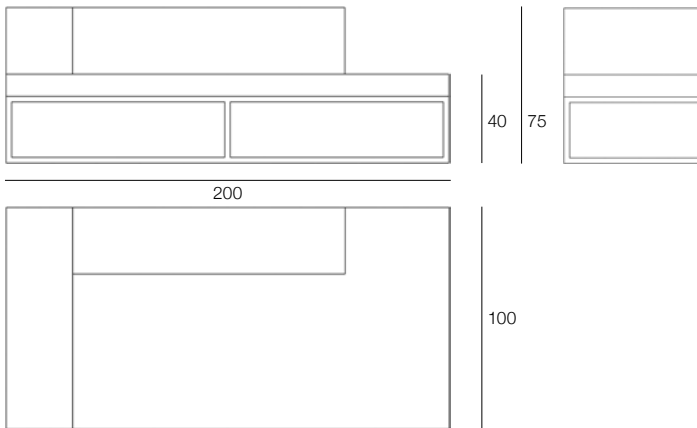

MANH8212

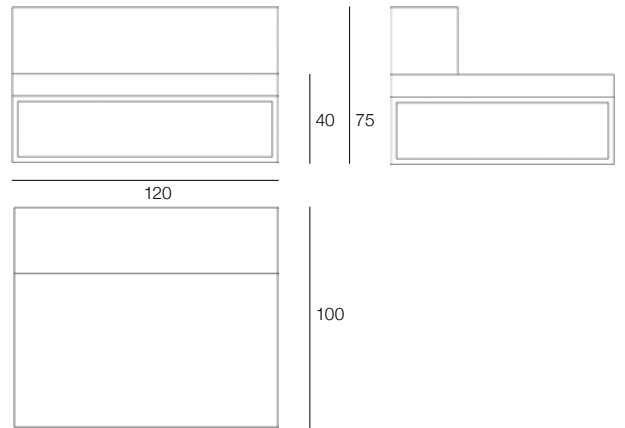

MANH8211

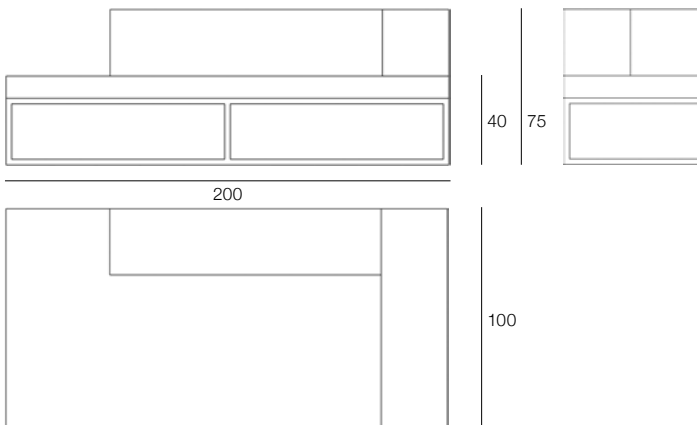

MANH8213

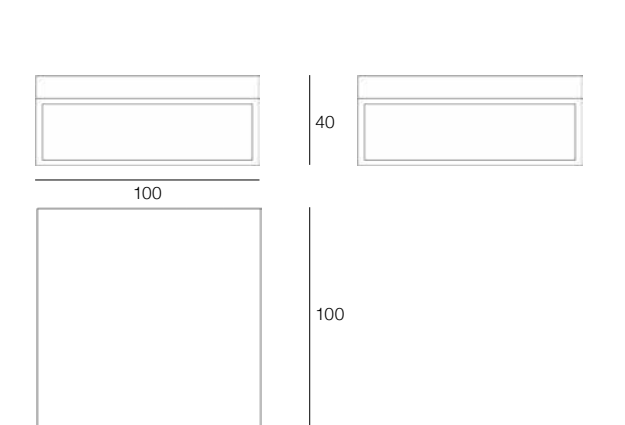

MAUI

design by CRS SILAT

Struttura in alluminio vergine con intreccio in fibra sintetica. Curve ridotte al minimo, linee decise e squadrate. Sedute lounge, sistema componibile e letti da sole completati da cuscini in gommapiuma con fodera protettiva rivestita in tessuto acrilico sfoderabile. Piedini in alluminio con vite regolabile per adattarsi a pavimentazioni non in piano. Elementi di bloccaggio permettono di creare elementi solidali tra loro adatti anche ad uso intensivo. Poltroncine con rivestimento del bracciolo in legno di Teak. Tavoli con piedini in alluminio ed elemento antigraffio in Teflon. Sovra-piano in vetro disponibile su richiesta. Proposto in nero.

Virgin aluminium frame covered by synthetic fiber with minimalist curves and bold, clean-cut lines. Lounge chairs, modular system and sun loungers completed by foam cushions with internal protective lining and removable acrylic fabric cover. Aluminium feet with adjustable screw for uneven floors fitting. Fastening elements make it possible to combine the elements at will, also for intensive use. Lounge chairs with Teak wood armrest. Tables with aluminium feet and anti-scratch Teflon element. Glass top available on request. Standard colour is Black.

MAUI4205 + MAUI4205-CUS



MAUI4215 + MAUI4215-CUS



MAUI4206 + MAUI4206-CUS



MAUI4416



MAUI4417



MAUI4205

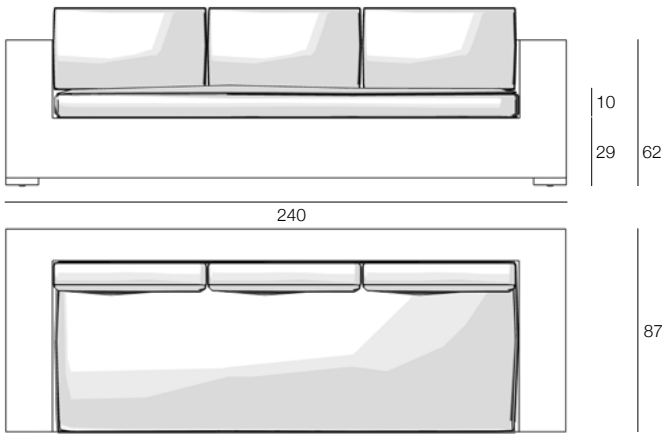

MAUI4215

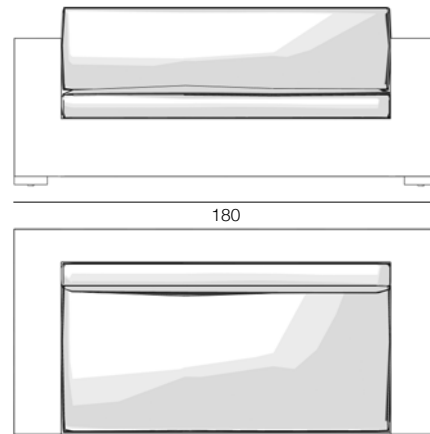

MAUI4206

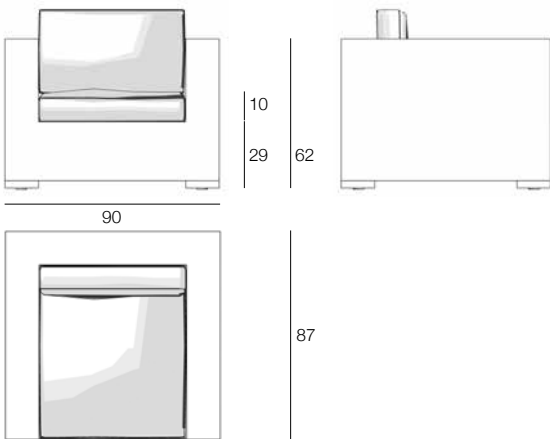

MAUI4416

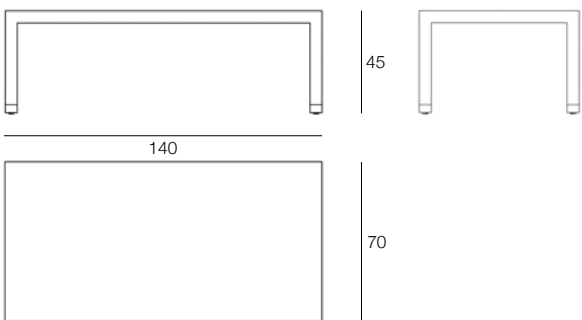

MAUI4417

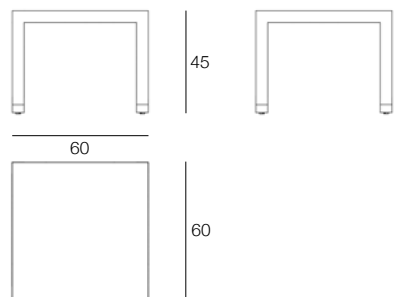

MAUI4211 + MAUI4211-CUS



MAUI4207 + MAUI4207-CUS



MAUI4208 + MAUI4208-CUS



MAUI4209 + MAUI4209-CUS



MAUI4210



MAUI4210 + MAUI4210-GLS



1 X MAUI4207 + MAUI4207-CUS
1 X MAUI4208 + MAUI4208-CUS
1 X MAUI4209 + MAUI4209-CUS

2 X MAUI4207 + MAUI4207-CUS
1 X MAUI4208 + MAUI4208-CUS

MAUI4211

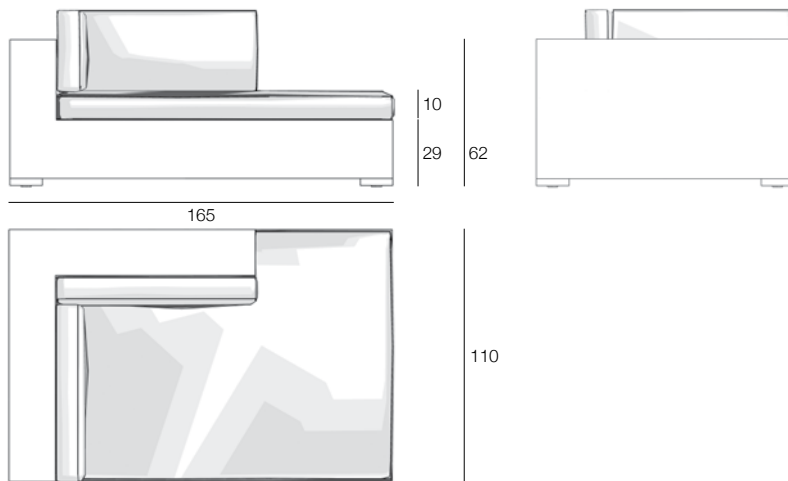

MAUI4207

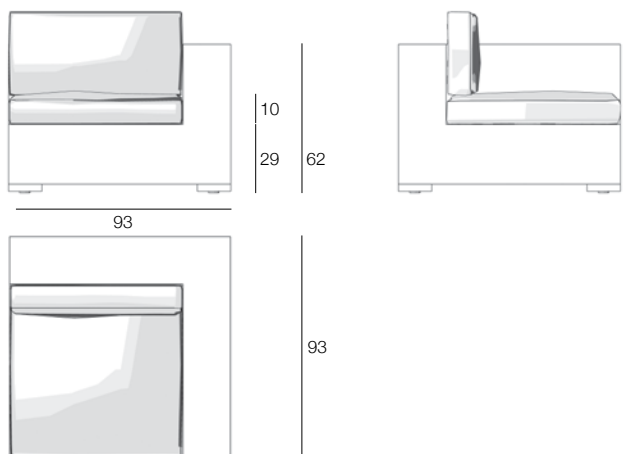

MAUI4208

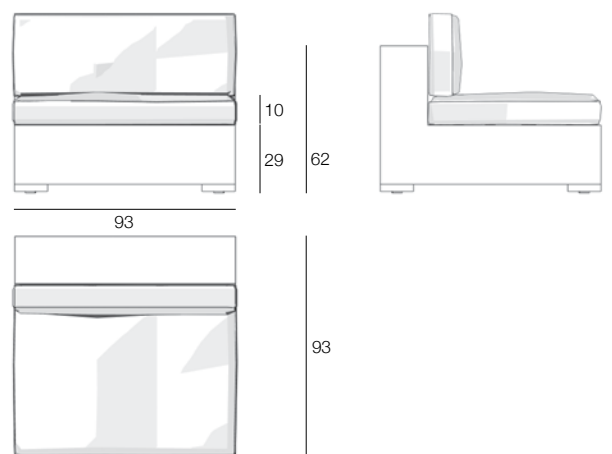

MAUI4209

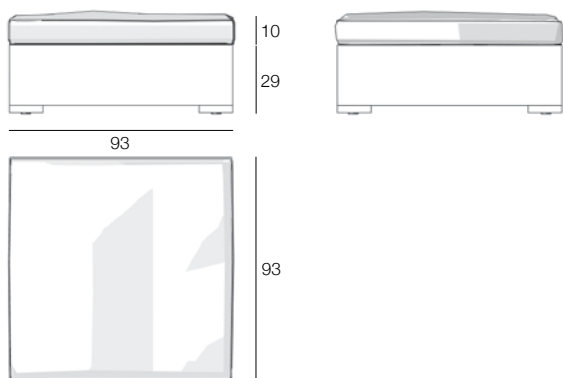

MAUI4210

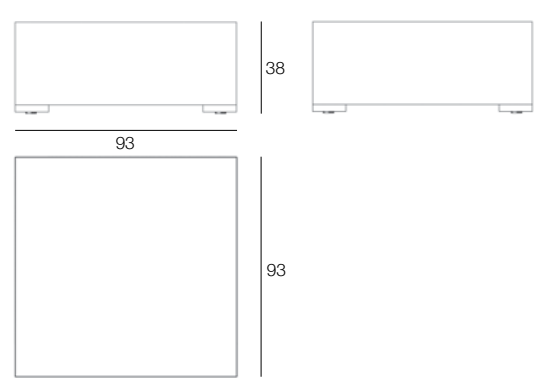

MAUI4314



MAUI4415



MAUI4414



MAUI4314

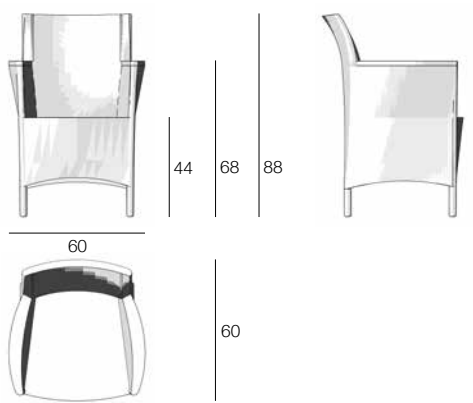

MAUI4415

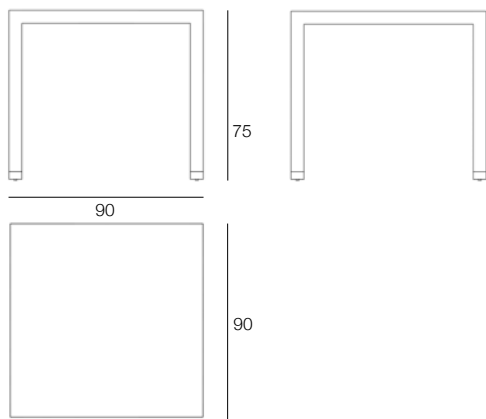

MAUI4414

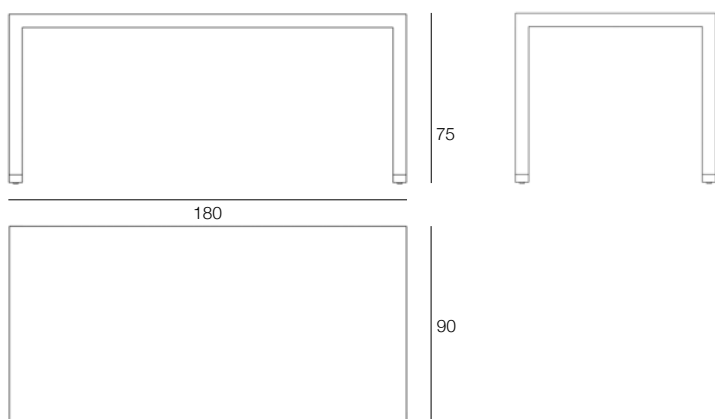

MAUI4511



MAUI4511 + MAUI4511-CUS



MAUI4507 + MAUI4507-CUS



MAUI4511

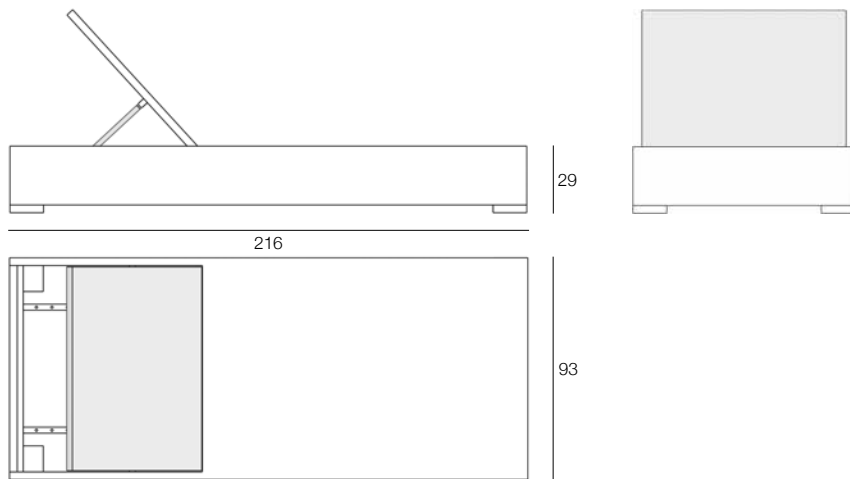

MAUI4507

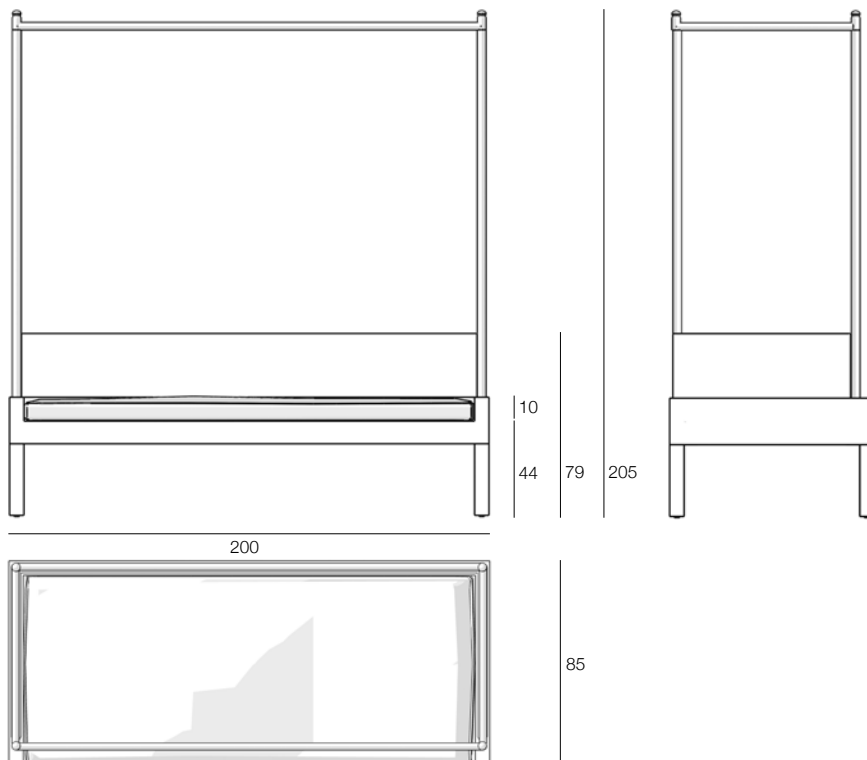

MOON

design by CRS SILAT

Realizzata in legno di teak a finitura naturale e con ferramenta in ottone. La sedia a sdraio è disponibile con ferramenta in ottone oppure in acciaio. Ad eccezione del dondolo, smontabile, l'intera collezione è caratterizzata da elementi pieghevoli con ingombri minimi quando chiusi.

Crafted in Fine Sanded teak wood with brass hardware. The deck chair is available with brass or stainless steel hardware. Except for the rocker, which can be removed and the structure dismantled, the entire collection is characterized by folding elements that require minimum storage space.

MOON0320



MOON0320 + MOON0836



MOON0320



MOON0320

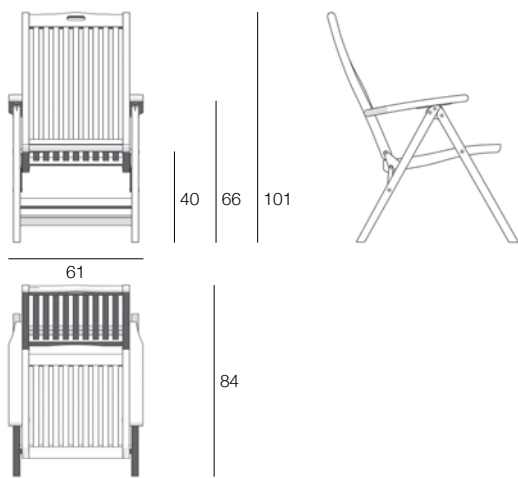

MOON0836

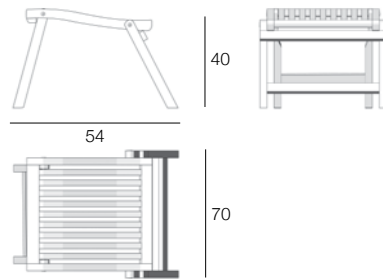

MOON0327



MOON0327

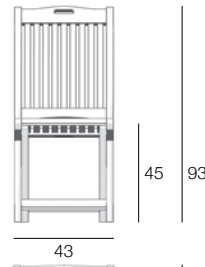

MOON0328



MOON0328

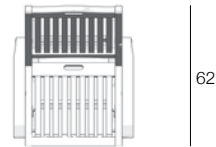
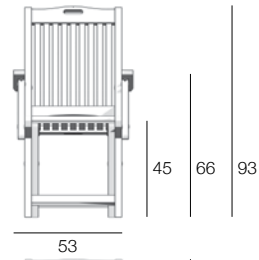

MOON0331



MOON0331

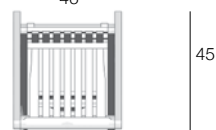
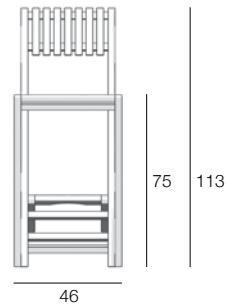



MOON0327
MOON0328
MOON0448

MOON0407



MOON0409



MOON0408



MOON0408



MOON0421



MOON0448



MOON0407

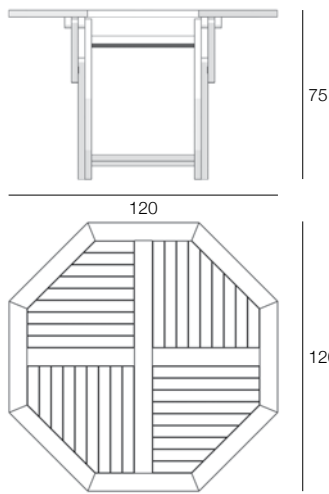

MOON0409

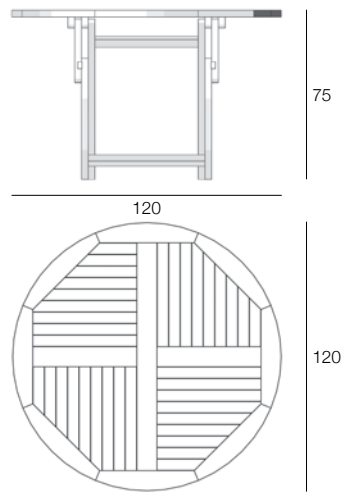

MOON0408

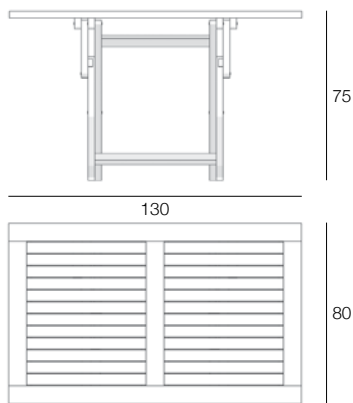

MOON0421

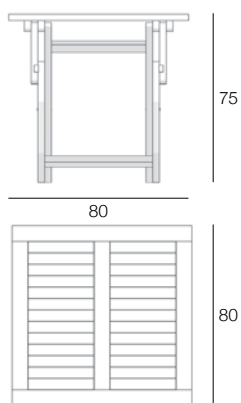

MOON0448

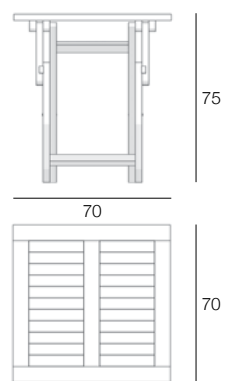

MOON0501 + MOON0501-CUS



MOON0529



MOON0501

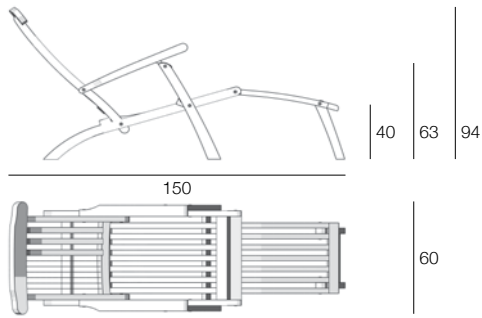

MOON0816



MOON0816

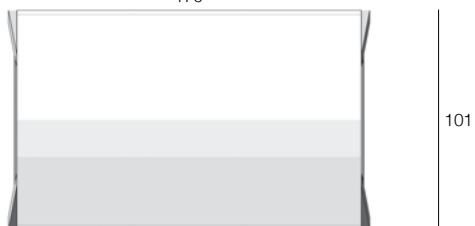
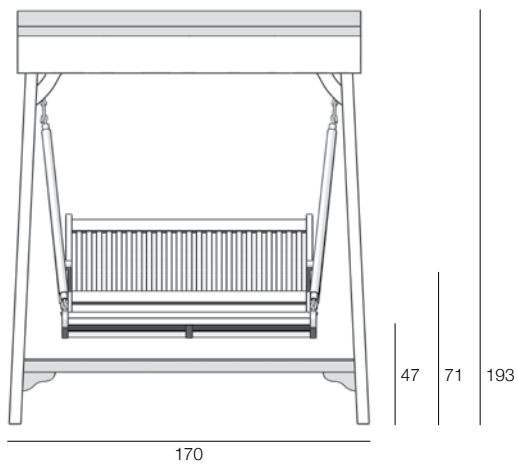



MOON0501
BONGO471

MOZAIC

design by CRS SILAT

Design e materiali classici, con gambe e schienali dalle linee arrotondate e sinuose. Piani dei tavoli in marmo oppure in vimine intrecciato e sovra-piano in vetro. Sedute e schienali disponibili in imbottito oppure in vimine intrecciato. Materiali da interno (Mogano, poliestere e vimine naturale) oppure da esterno (Teak, acrilico e fibra sintetica) in base alla richiesta. Proposto in noce e crema con dettagli azzurri nella versione *lounge* e grigio per gli elementi *dining*.

Classical design and materials, characterised by rounded, sinuous legs and backrest. Marble or woven wicker table tops with glass cover. Available with padded or woven wicker seats and backrests. Internal materials (Mahogany, polyester and natural wicker) or external materials (Teak, acrylic and synthetic fibre) as requested. Standard colour is walnut and cream with blue details for lounge elements, gray for the dining sets.

MOZA0241



MOZA0242



MOZA0480



MOZA0242



MOZA0479



MOZA0241

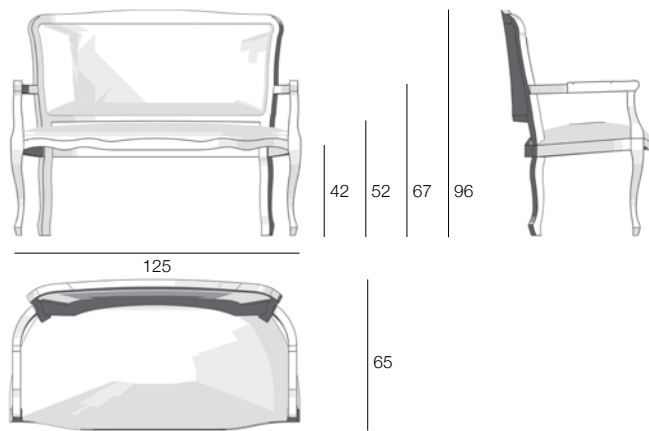

MOZA0242

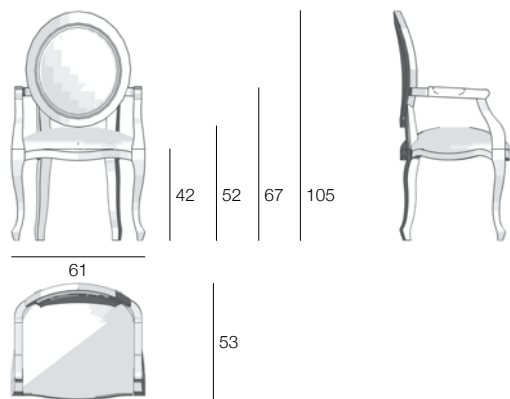

MOZA0480

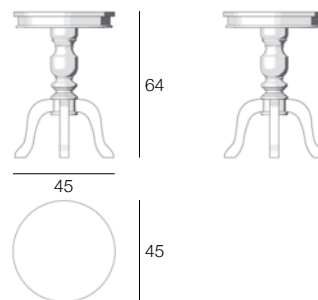

MOZA0479

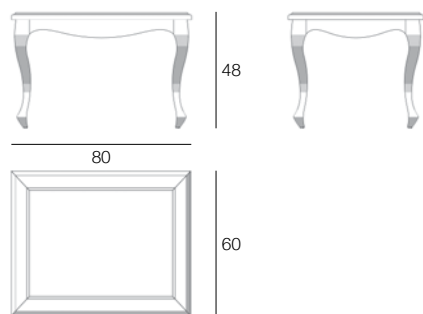

MOZA0351



MOZA0352



MOZA0353



MOZA0354



MOZA0355



MOZA0356



MOZA0357



MOZA0358



MOZA0359



MOZA0351

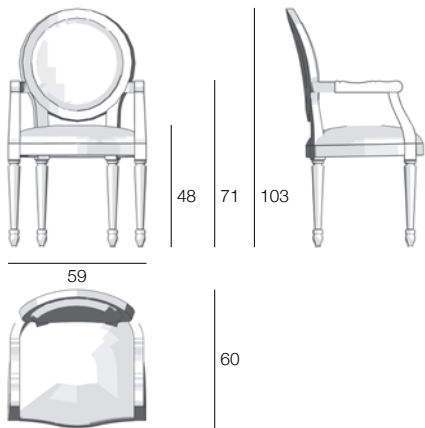

MOZA0352

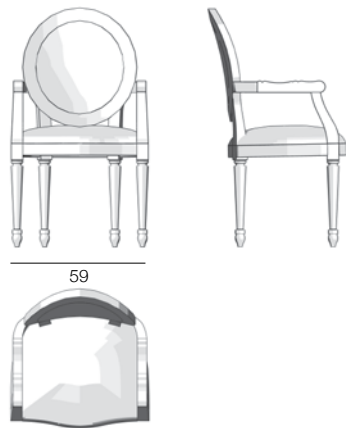

MOZA0353

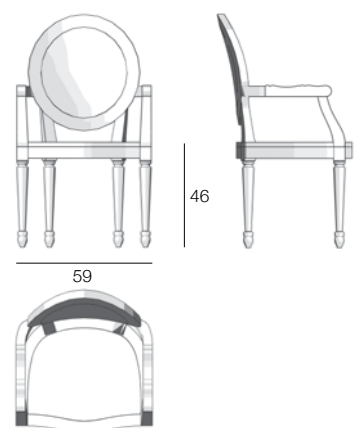

MOZA0354

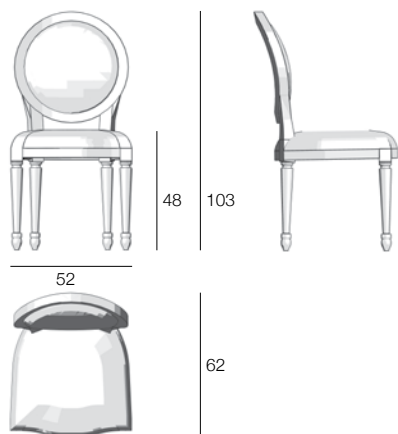

MOZA0355

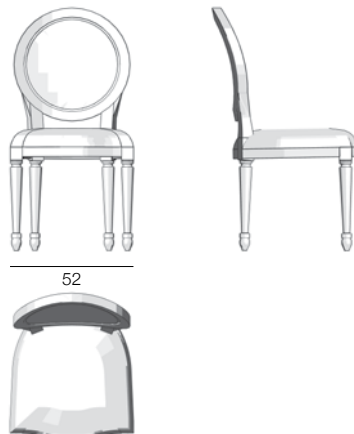

MOZA0356

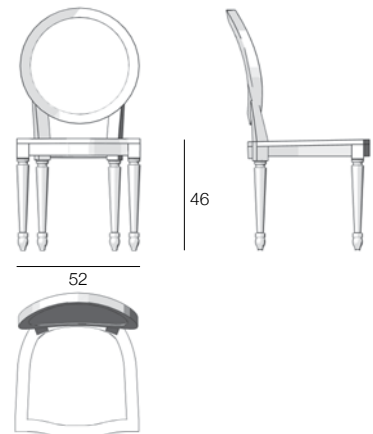

MOZA0357

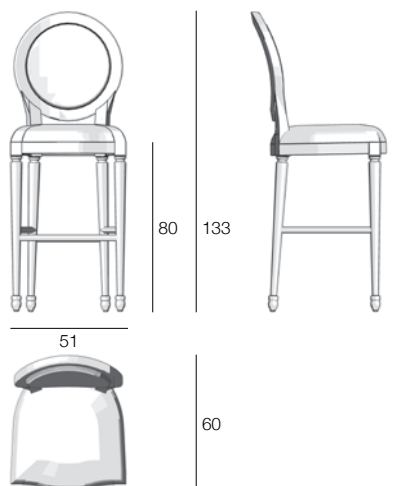

MOZA0358

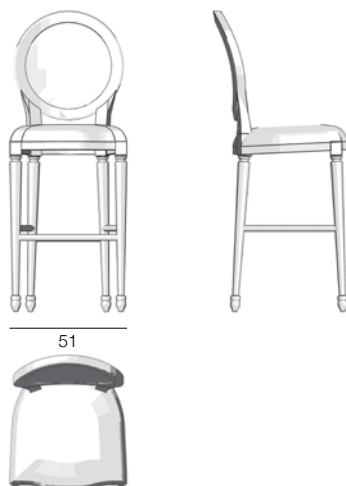

MOZA0359

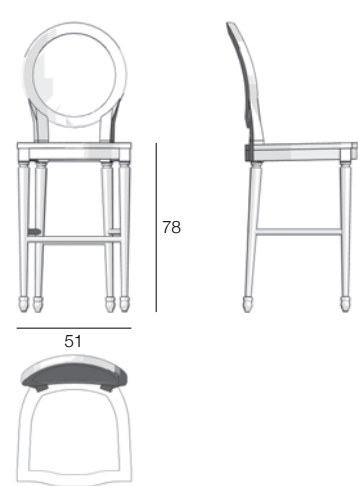

MOZA0477



MOZA0478



MOZA0477

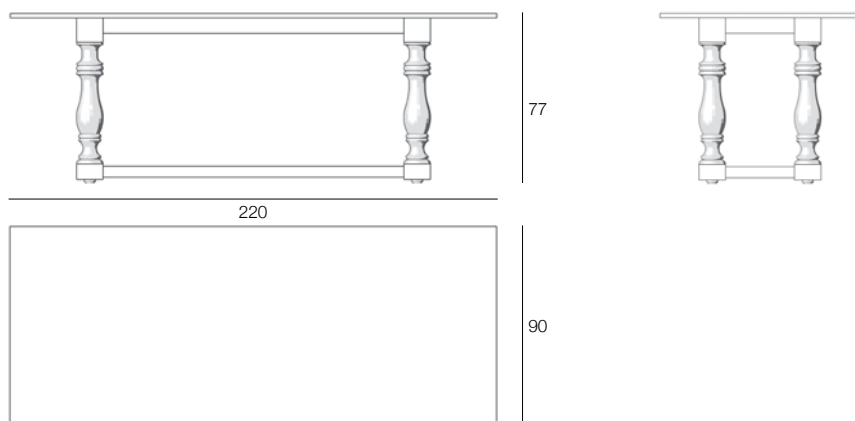

MOZA0478

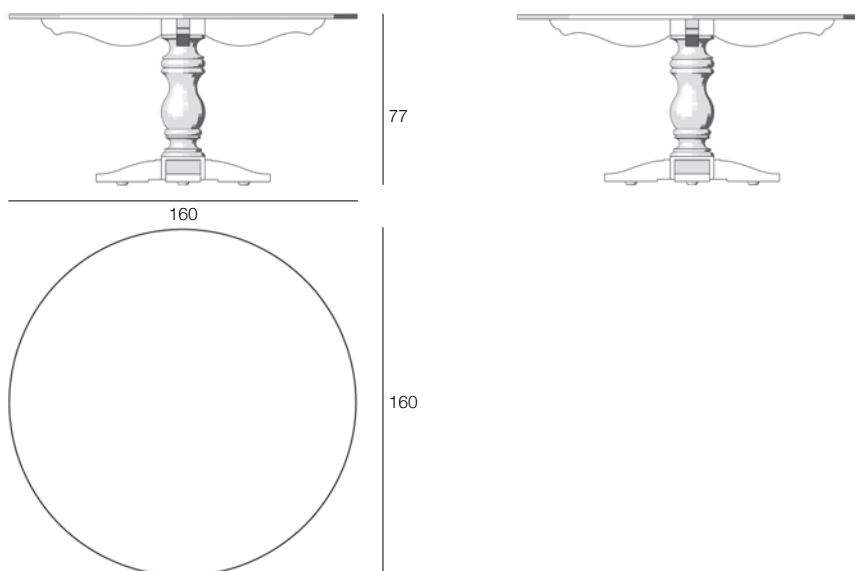

OTTO

design by CRS SILAT

Struttura in tubolare di alluminio trattato con bagno di pulitura e verniciato a polveri. Sedute e schienali delle sedie in filo di poliestere rivestito in PVC tessuto e intrecciato a mano, nella versione Talpa combinato con fibra di canapa. Piani dei tavoli in massello di Teak con finitura naturale. Alluminio verniciato a polveri con finitura nera opaca o bianca semi lucida.

Cleansed, powder coated tubular aluminium structure. Seats and backs of the chairs in hand-woven and twisted PVC covered polyester wire; the Talpa version is combined with hemp fibre. Table surfaces in Fine Sanded Teak wood. Powder coated aluminium in black doff or semi-glossy white.

OTTO0301_DB



OTTO0301_SW



OTTO0401_FSDB



OTTO0401_FSSW



OTTO0301

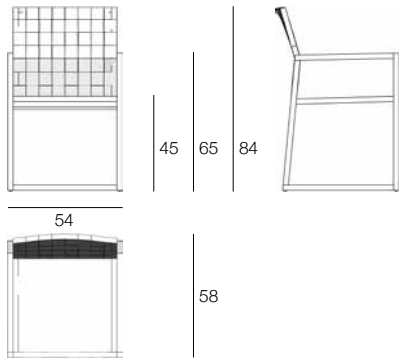

OTTO0401

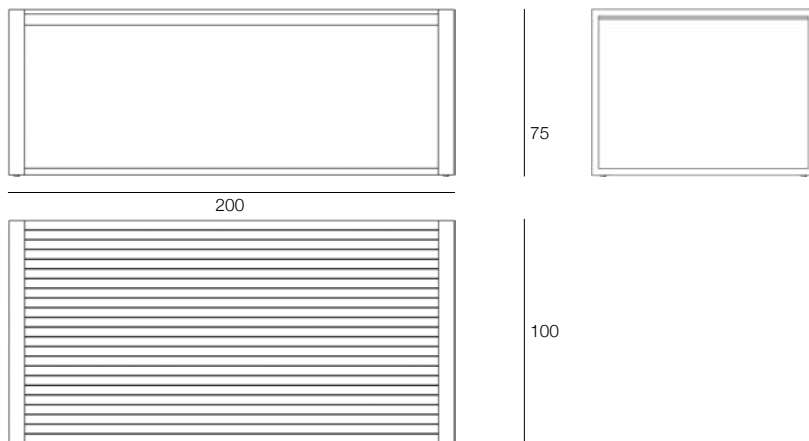

PEBBLES

design by SAM SANNIA

La collezione di arredi per esterno Pebbles si ispira alla rotondità dei sassolini consumati dal mare (i 'pebbles', o piccoli ciottoli). La forma degli elementi principali richiama l'idea di morbidezza, enfatizzata dal contrasto con la linearità della struttura e dal calore del legno massello. La finitura proposta è levigatura fine naturale.

The outdoor furniture collection Pebbles is inspired by the roundness of the seawater-worn little rocks (the 'pebbles'). The warmth of the wood and the rounded shapes, in contrast with the more linear structure, give pleasantness to these furnishings, even in the everyday use. Standard version is in Fine Sanded Teak wood.

PEBL0361



PEBL0361



PEBL0482



PEBL0361

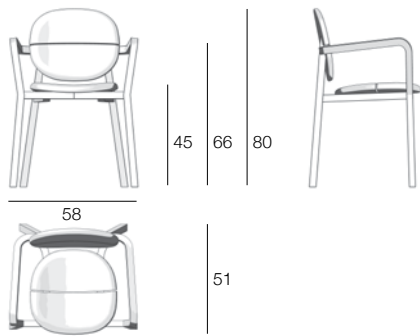

PEBL0482

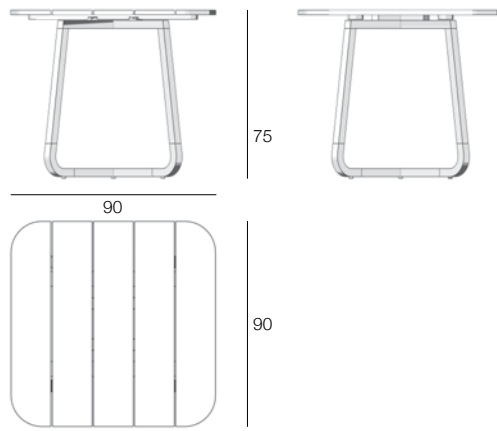

PEBL0482



PEBL0361

PORTER

design by CRS SILAT

PORT0866

Struttura in Mogano o Teak e vimine naturale. Linea avvolgente, dall'aria vintage. Il paravento, con struttura in legno di Teak, completa la collezione per offrire un angolo di privacy nel proprio giardino. Il legno è proposto con finitura neutra opaca, il rattan è a finitura non pigmentata semi-lucida.

Mahogany or Teak wood and natural wicker frame. Wrap-round vintage style design. The screen with Teak structure completes the collection to create a private corner in your garden. Standard version is proposed with clear doff finishing wood and transparent semi-glossy rattan.



PORT0240



PORT0866

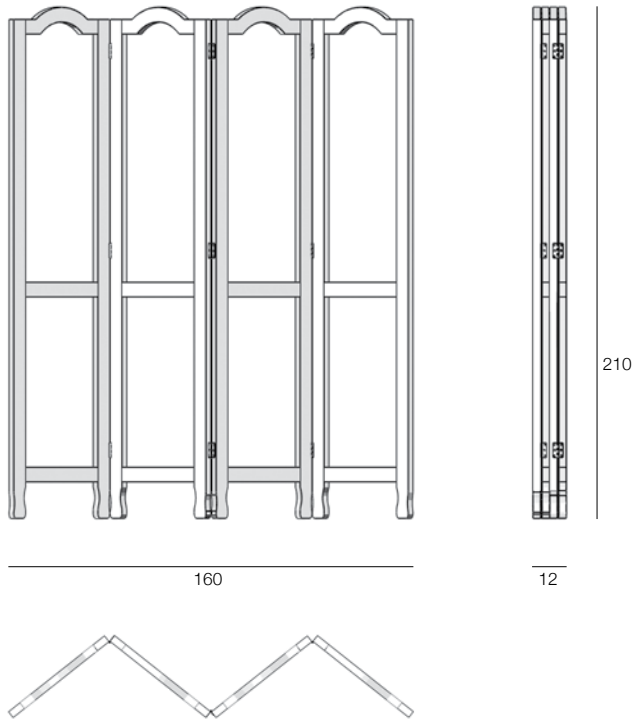

PORT0240

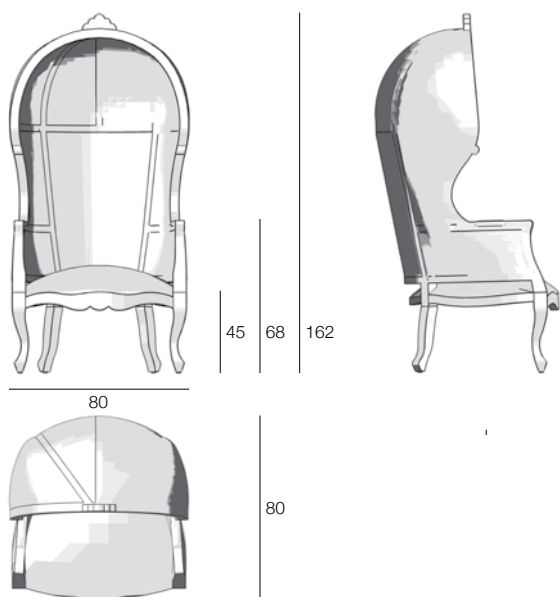

RADICE

design by NATURE

Queste panche di Teak sono oggetti unici, recuperati dalle radici e da tronchi usurati dal tempo e rifiniti seguendo la loro natura. Proposti in finitura protettiva.

Dimensioni:

Sedia RADIO246 ca 100cm

Panca RADIO247 max 135cm

Panca RADIO248 135-155cm

Panca RADIO249 >155cm

Sgabello RADIO360 35x35 h45cm

Teak benches with unique shapes, recovered from naturally worn roots and logs, well-finished following their natural elements. Standard version with a layer of protective finishing.

Dimintions:

Chair RADIO246 ca 100cm

Bench RADIO247 max 135cm

Bench RADIO248 135-155cm

Bench RADIO249 >155cm

Stool RADIO360 35x35 h45cm

RADIO360



RADIO246



RADIO247



RADIO248



RADIO249



RADIO248



RATIO

design by CRS SILAT

Struttura costituita da componenti a sezione quadrata di grande spessore in legno di Teak. Sedia con alto schienale caratterizzato dall'elegante curvatura dei listelli. Letti da sole con o senza baldacchino. Cabana disponibile con copertura in fibra sintetica intrecciata a stuoia e/o tende laterali. La collezione è proposta in finitura Fine Sanded.

Square-section, extra-thick Teak woodframe. High-back seat with elegantly curved slats. Sun loungers with or without canopy. Cabana available with woven synthetic wicker cover and/or side curtains. Teak wood has Fine Sanded as standard finish.

RATIO227



RATIO417



RATIO319



RATIO437



RATIO227

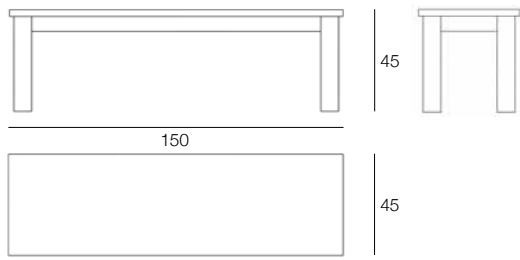

RATIO417

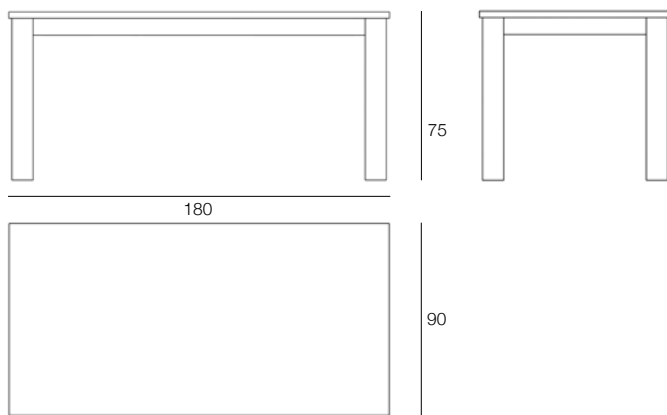

RATIO319

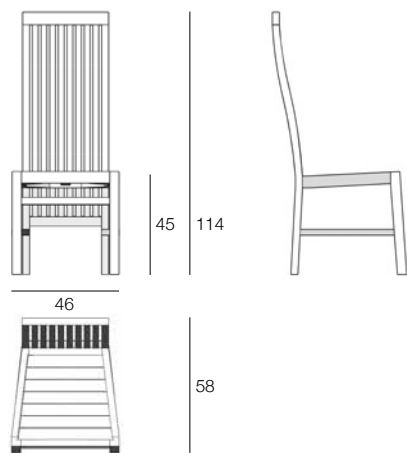

RATIO437

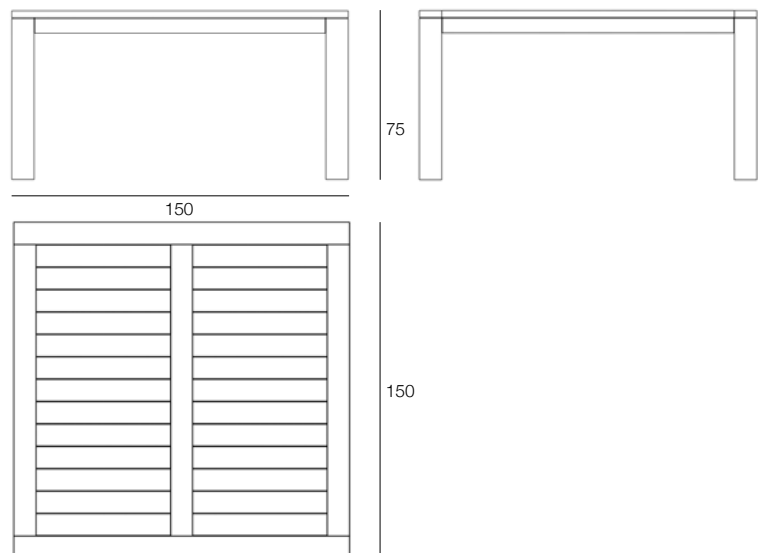

RATI0525 + RATI0525-CUS



RATI0526 + RATI0526-CUS + RATI0526-CRT + RATI0526-RRC



RATI0525

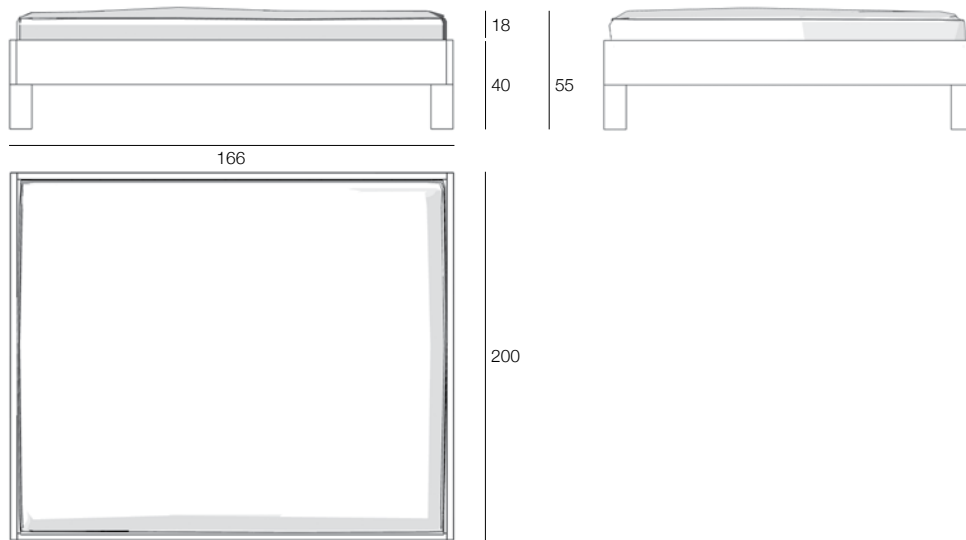

RATI0526

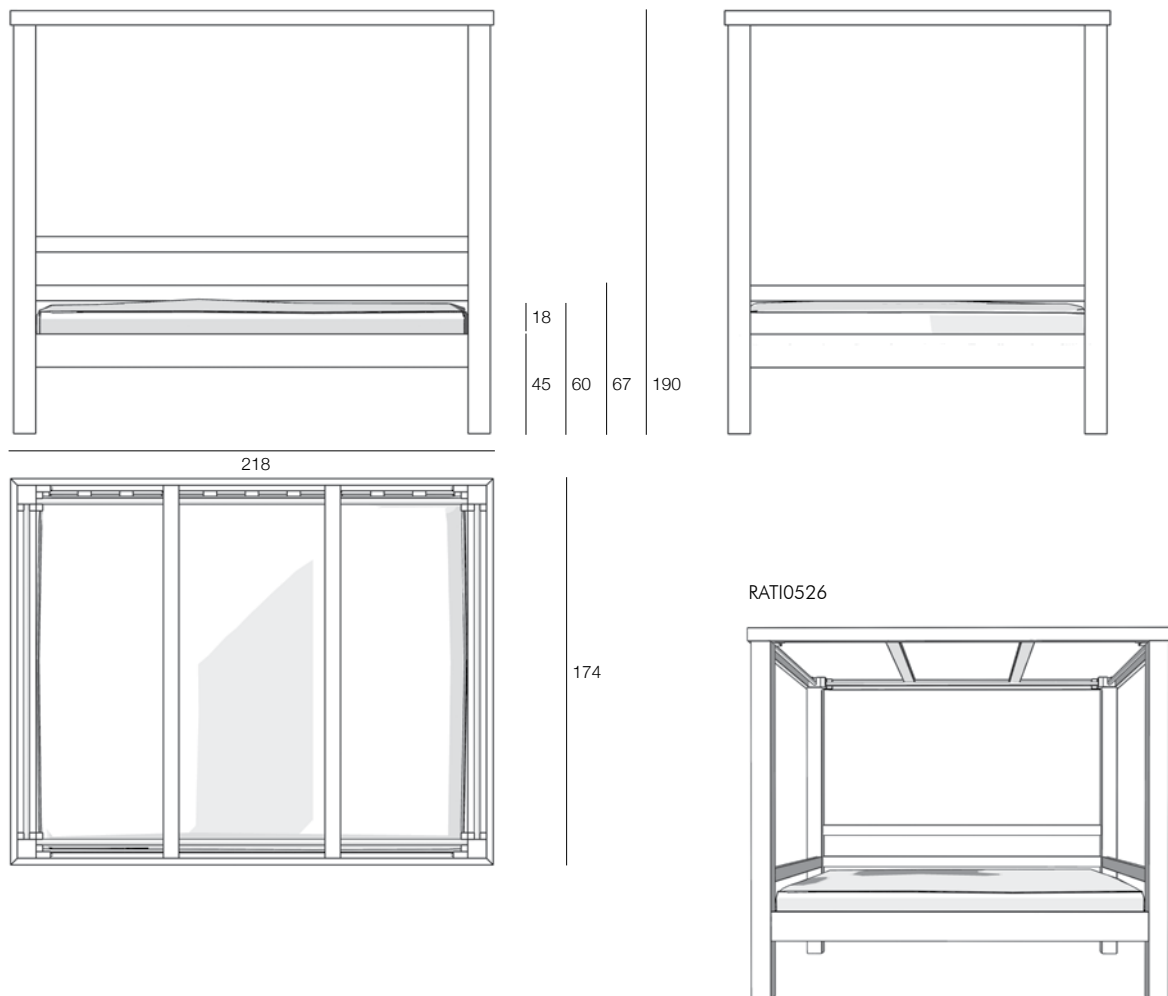

REGISTA

design by CRS SILAT

Struttura in legno di Teak e tela in tessuto acrilico. Su richiesta in altri materiali. Tavoli a piantana disponibili con piano quadrato o rotondo. Ferramenta in ottone per le sedie e in acciaio per i tavoli. Proposta in Teak a finitura naturale e tela in colore ecrù.

Teak wood frame with Fine Sanded finish and natural colour acrylic canvas. Other materials on request. Pedestal tables available with square or round top. Brass hardware for seats, stainless steel for tables.

REGI0310 + K01



REGI0701 + K01



REGI0701 + K02



REGI0310

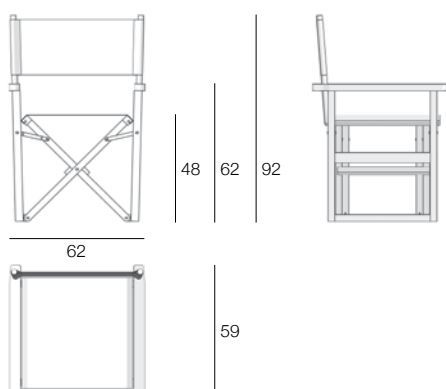

REGI0701 + K01

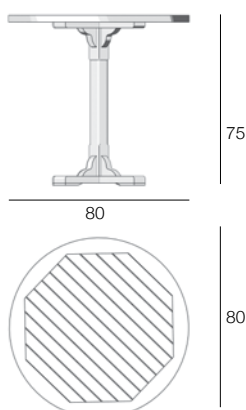

REGI0701 + K02

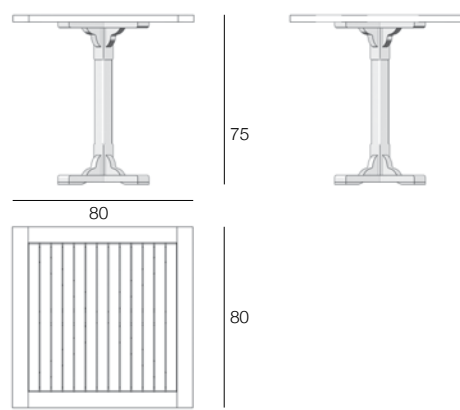



RIVIERA

design by CRS SILAT

Questa sedia sdraio in legno di Teak con poggiatesta è la riproposizione di una famosissima sedia che fu disegnata nel 1903 da Thomas Lee, quando era in vacanza a Westport, New York, per la sua residenza estiva. La sedia venne poi chiamata 'Westport Plank Chair' e conosciuta anche come 'Adirondack'. La collezione Riviera si caratterizza per uno schienale e una seduta arrotondati; i braccioli sono larghi e con un ampio piano d'appoggio. Il legno è proposto in finitura a levigatura fine naturale.

This Teak wood deckchair with foot rest is a re-interpretation of the famous chair originally designed by Thomas Lee in 1903 for his summer home when holidaying in Westport, New York. The chair was subsequently dubbed the "Westport Plank Chair" and also known as "Adirondack". The Riviera collection features rounded backrest and seat and long, flat arms able to accommodate a refreshing drink. Fine Sanded is the standard finishing.

RIVI0502



RIVI0502

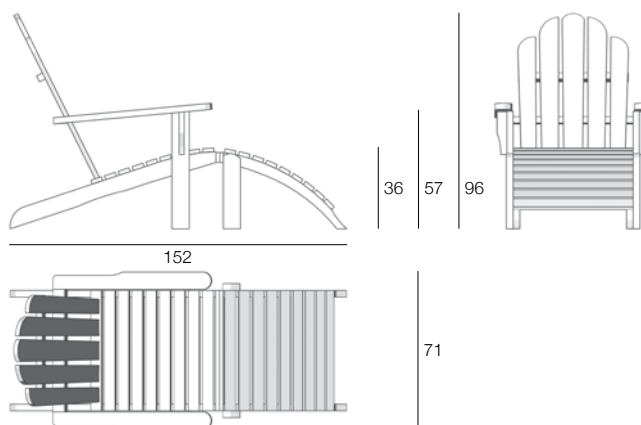



RIVI0502
DEH00422

SAINT LAURENT

design by CRS SILAT

STLA0234 + STLA0234-CUS



Realizzata in legno massello di Teak. I cuscini sono sfoderabili e realizzati in tessuto acrilico da esterno. La bellezza materica del legno rimane il filo conduttore della collezione: naturalità ed eco sostenibilità. La generosità degli elementi imbottiti costituisce un elemento caratterizzante per le sedute da esterno. I lettini prendisole sono disponibili in versione singola o doppia e sono dotati di ruote in Teflon con cuscinetti a sfera, ideali per il bordo piscina. Personalizzazioni per posizionamento in spiaggia da effettuarsi su richiesta. Il legno è proposto in finitura a levigatura fine naturale.

STLA0338 + STLA0338-CUS



Made of solid Teak. Cushions removable cover made of acrylic fabric suitable for outdoor use. The beauty of the wooden matter is the leitmotif of the collection: naturalness and ecosustainability. The generosity of upholstered elements is a feature for outdoor seating. The sun beds are available in single or double version and are fitted with Teflon wheels with bearings, ideal for pool side use. Customisations for positioning on beach available on request. Fine Sanded is the standard wood finishing.

STLA0444



STLA0444 + STLA0444-CUS



STLA0449



STLA0515 + STLA0515-CUS



STLA0514 + STLA0514-CUS



STLA0514 + STLA0514-CUS



STLA0234

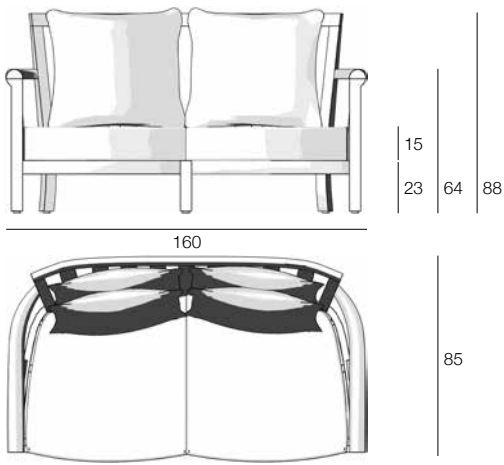

STLA0338

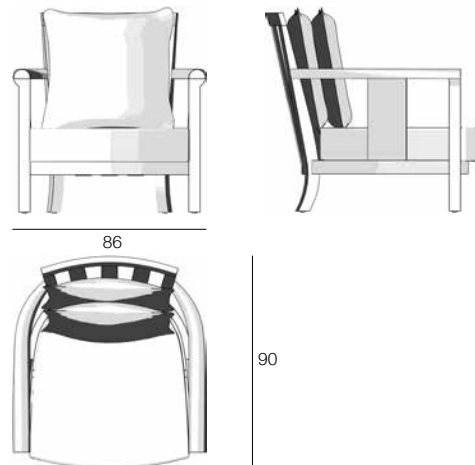

STLA0444

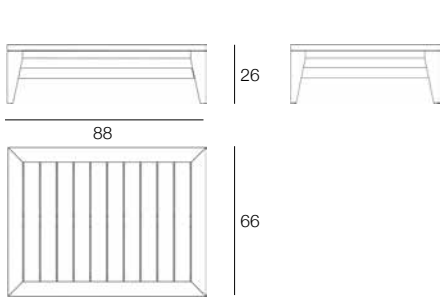

STLA0444 + STLA0444-CUS

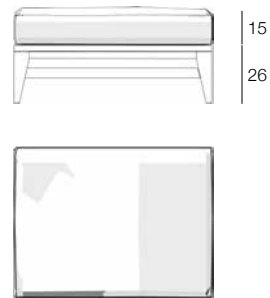

STLA0449

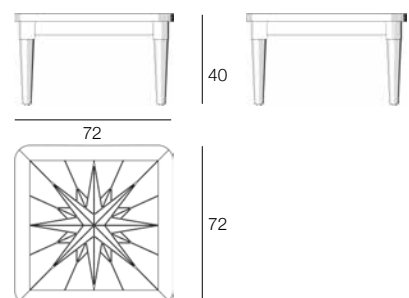

STLA0514-0515

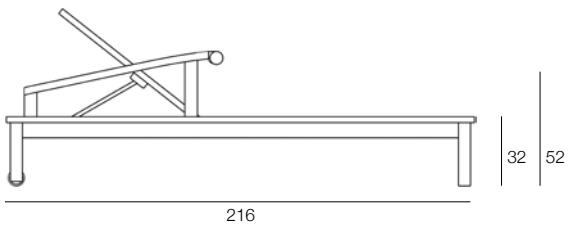

STLA0514

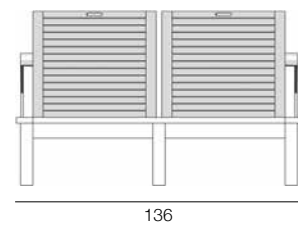

STLA0515

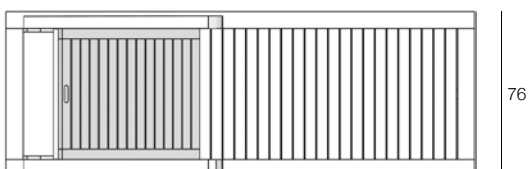
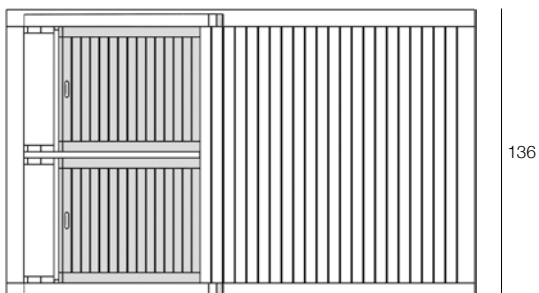
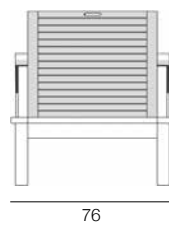

SAINT RAPHAEL

design by CRS SILAT

Collezione caratterizzata da cuscini ampi e spessi sostenuti da strutture lineari e squadrate in legno di Teak. Elementi di aggancio in ottone per gli elementi modulari. Tavolino con piano in vetro satinato. Lettini con ruote in Teflon e cuscinetti a sfera, ideali per pavimenti piani. Personalizzazioni per posizionamento in spiaggia da effettuarsi su richiesta. Il legno è proposto in finitura a levigatura fine naturale.

A collection characterised by large, plump cushions resting on linear, square-cut Teak wood frames. Brass fastening elements for lounge elements. Table with frosted glass top. Sun loungers with Teflon wheels and ball bearings, ideal for flat surfaces. Customisations for positioning on beach available on request. Fine Sanded is the standard wood finishing.

STRA0221 + STRA0221-CUS



STRA0220 + STRA0220-CUS



STRA0220 + STRA0220-CUS



STRA0222 + STRA0222-CUS



STRA0222 + STRA0222-CUS



STRA0224 + STRA0224-CUS



STRA0238 + STRA0238-CUS



STRA0223 + STRA0223-CUS



STRA0446



STRA0221

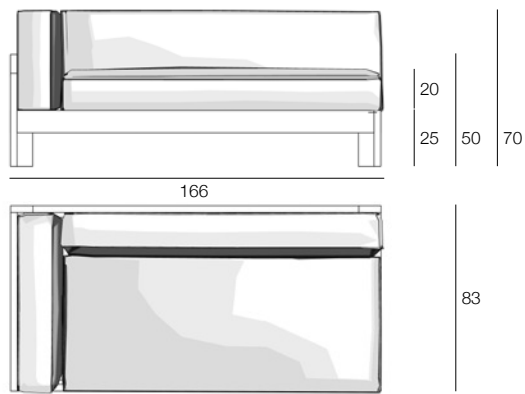

STRA0220

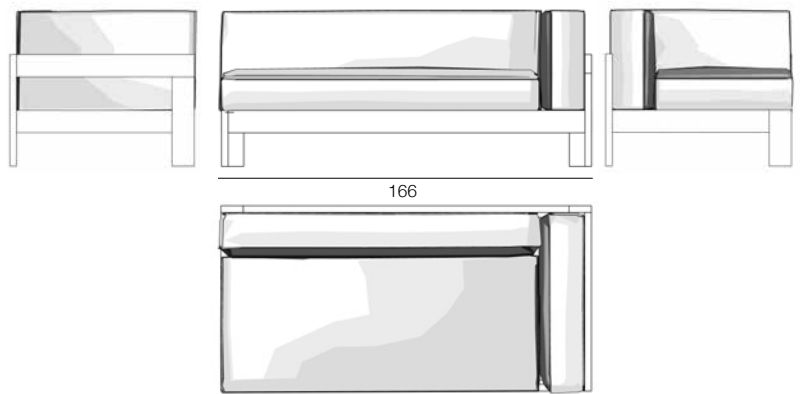

STRA0222

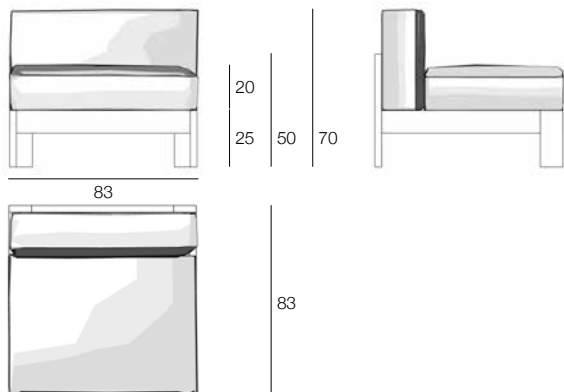

STRA0224

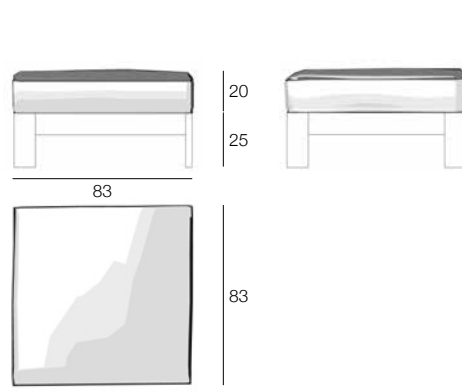

STRA0238

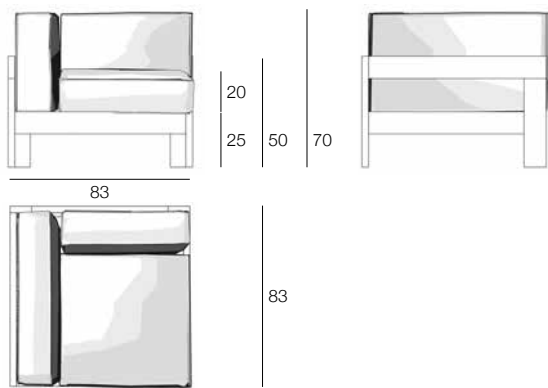

STRA0223

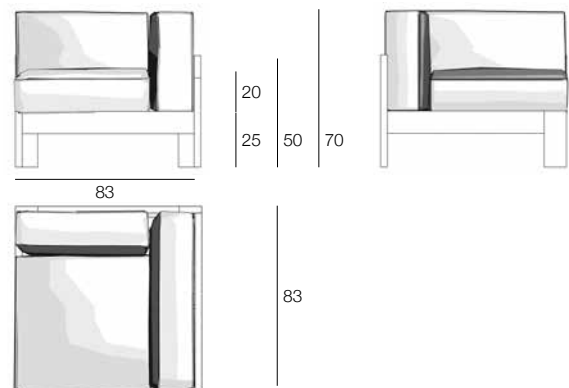

STRA0446

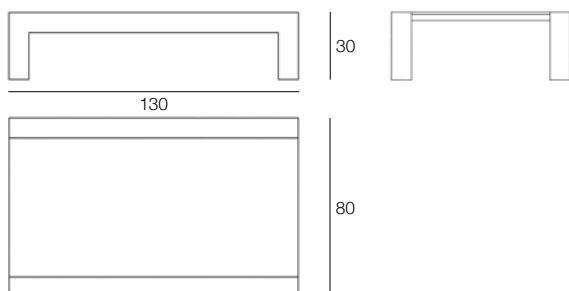

STRA0511 + STRA0511-CUS



STRA0530 + STRA0530-CUS



STRA0516



STRA0516 + STRA0516-CUS



STRA0511

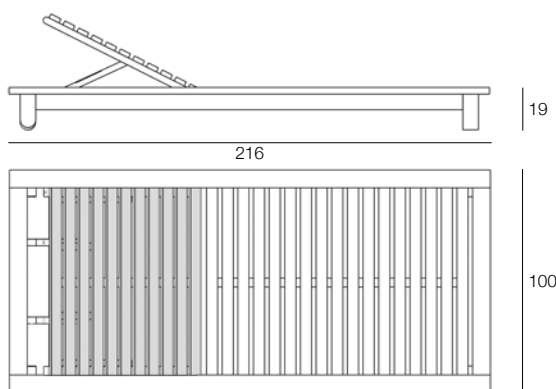

STRA0530

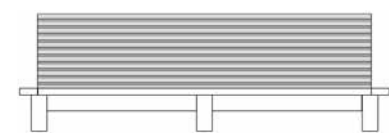
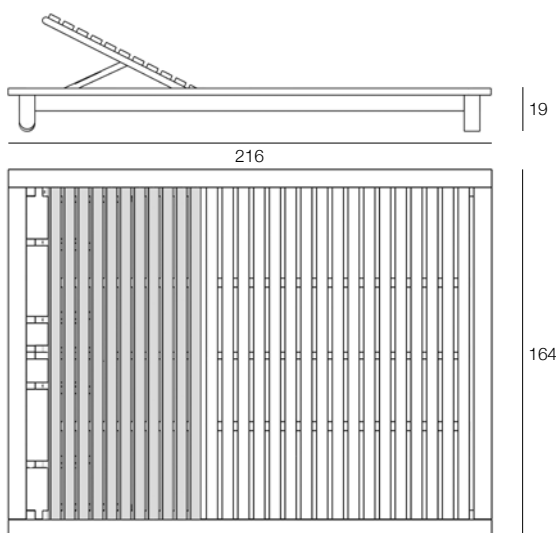

STRA0516

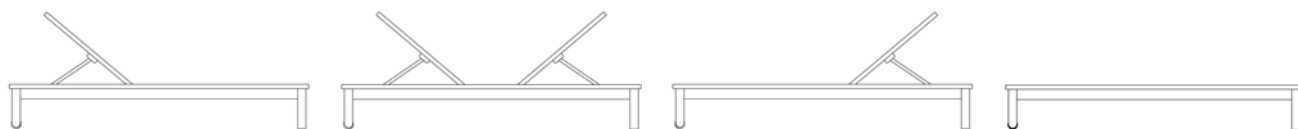
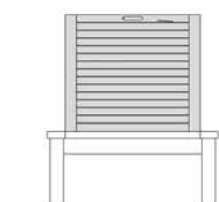
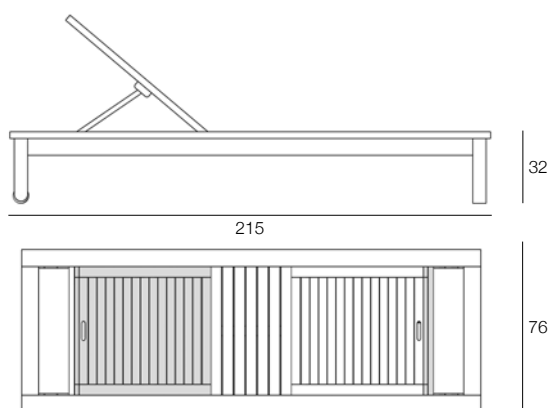

SAINT TROPEZ

design by CRS SILAT

Grande presenza visiva e strutturale del legno massello di Teak con motivo a liste orizzontali. Componenti di bloccaggio in ottone per gli elementi modulari. Tavolino rettangolare con piano in vetro satinato. Tavolino quadrato di dimensione tale da poter essere utilizzato anche nell'angolo di una composizione modulare. Lettino prendisole dotato di ripiano estraibile. Cabana personalizzabile con pavimento e/o pannelli laterali disponibili in due misure. Il legno è proposto in finitura a levigatura fine naturale.

Solid Teak wood with great visual impact and impressive structure with horizontal slat motif. Brass fasteners for modular elements. Rectangular tables with frosted glass top. The square table can be also used as corner element of a modular composition. Sun lounger with extractable tray. Customizable cabana with floor and/or side panels, available in two sizes. Fine Sanded is the standard wood finishing.

STTR0212 + STTR0212-CUS



STTR0212 + STTR0212-CUS



STTR0213 + STTR0213-CUS



STTR0213 + STTR0213-CUS



STTR0217 + STTR0217-CUS



STTR0239 + STTR0239-CUS



STTR0212

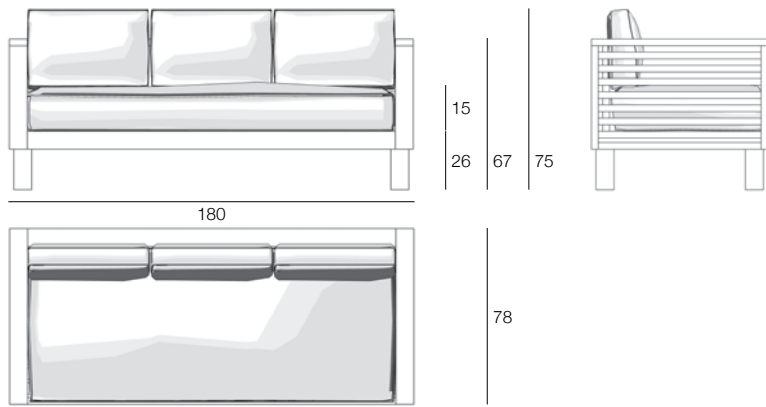

STTR0213

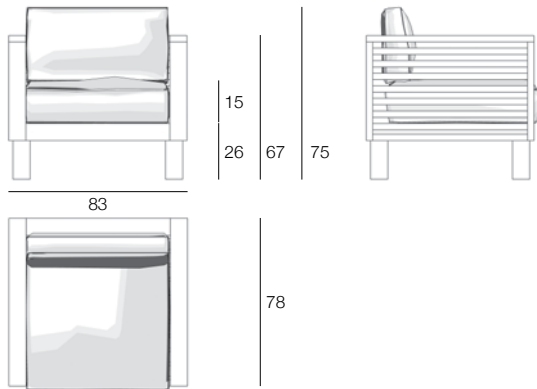

STTR0217

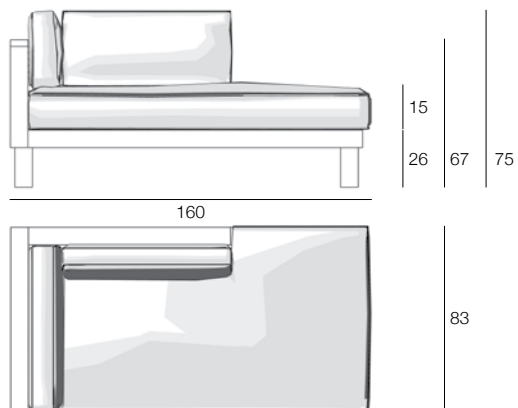

STTR0239

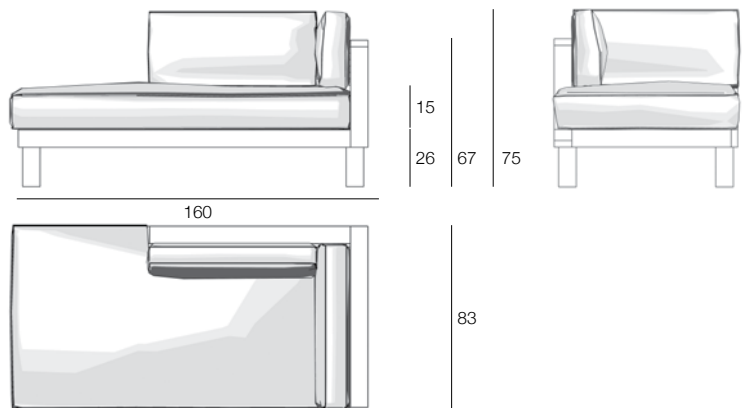

STTR0214 + STTR0214-CUS



STTR0214 + STTR0214-CUS



STTR0214 + STTR0214-CUS + STTR0214-BIS



STTR0215 + STTR0215-CUS



STTR0216 + STTR0216-CUS



STTR0442



STTR0443



STTR0443



STTR0517



STTR0517 + STTR0517-CUS



STTR0214

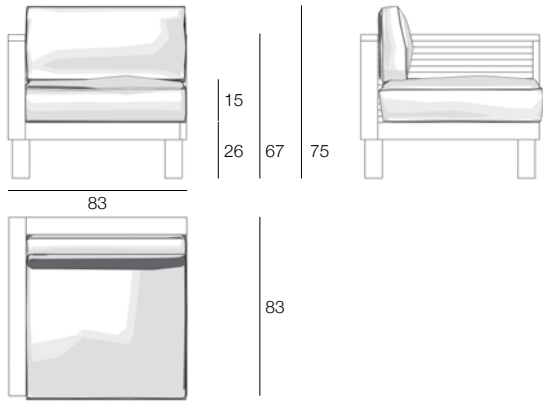

STTR0215

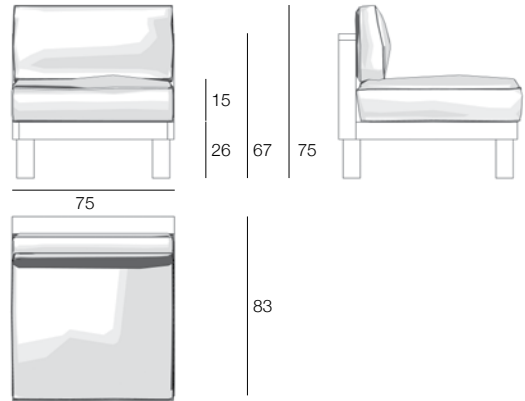

STTR0216

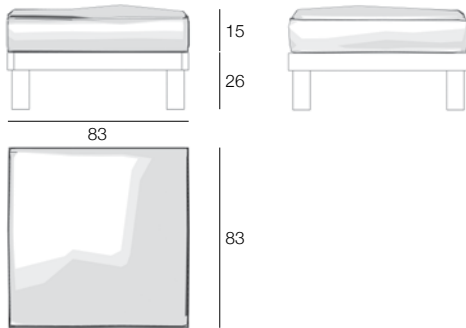

STTR0442

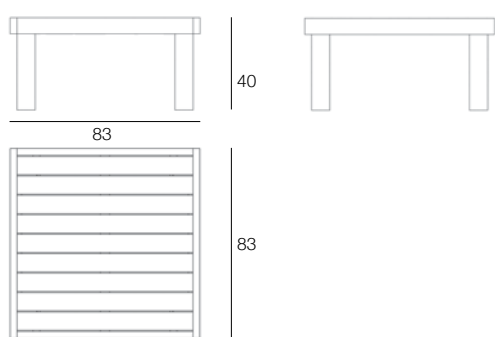

STTR0443

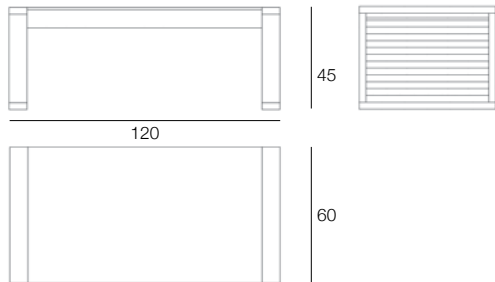

STTR0517

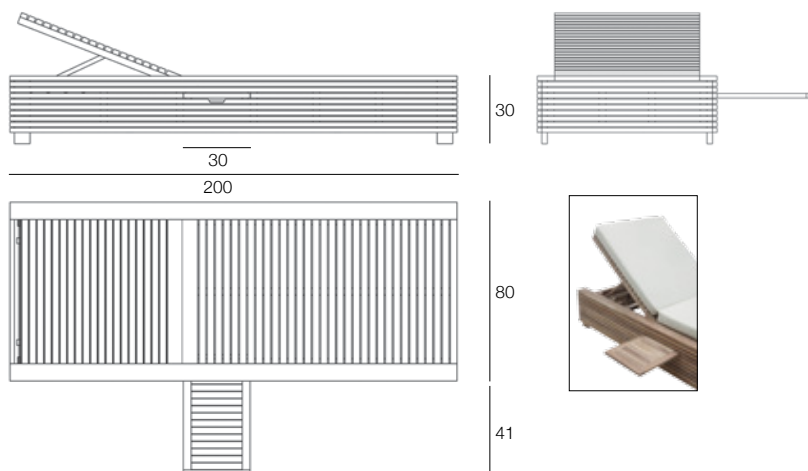

1 x STTR0807
1 x STTR0808



1 x STTR0807
1 x STTR0808
1 x STTR0809
1 x STTR0814



1 x STTR0807
1 x STTR0808
1 x STTR0809
1 x STTR0814
1 x STTR0807-RFA



STTR0807+STTR0808

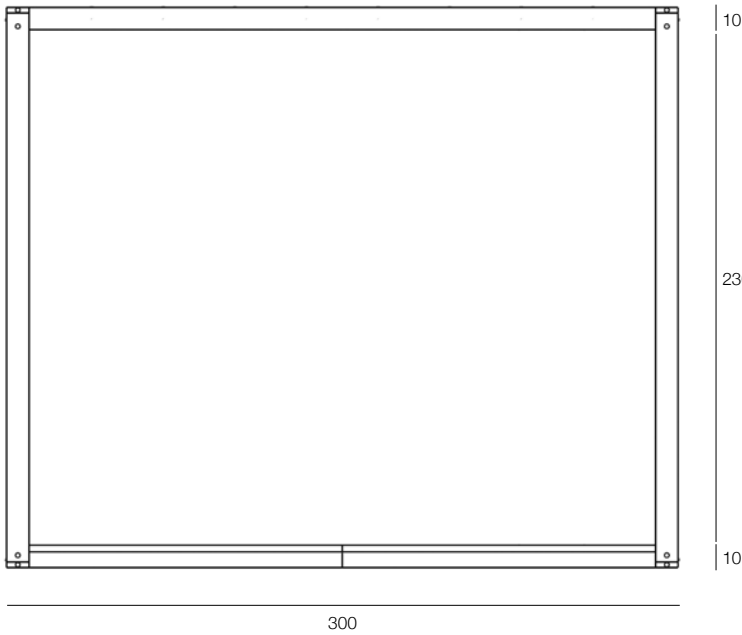

300

STTR0814

STTR0809

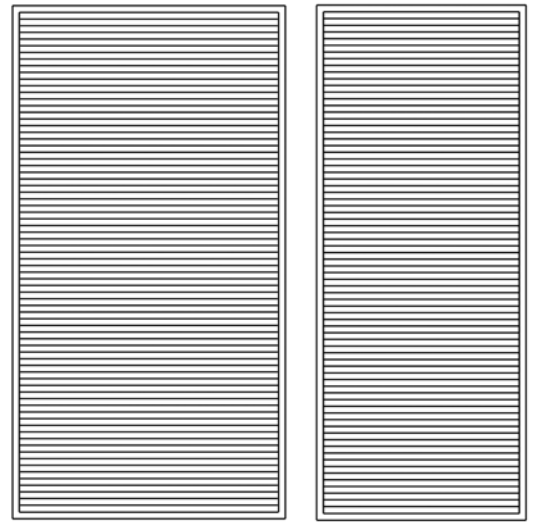

122

93

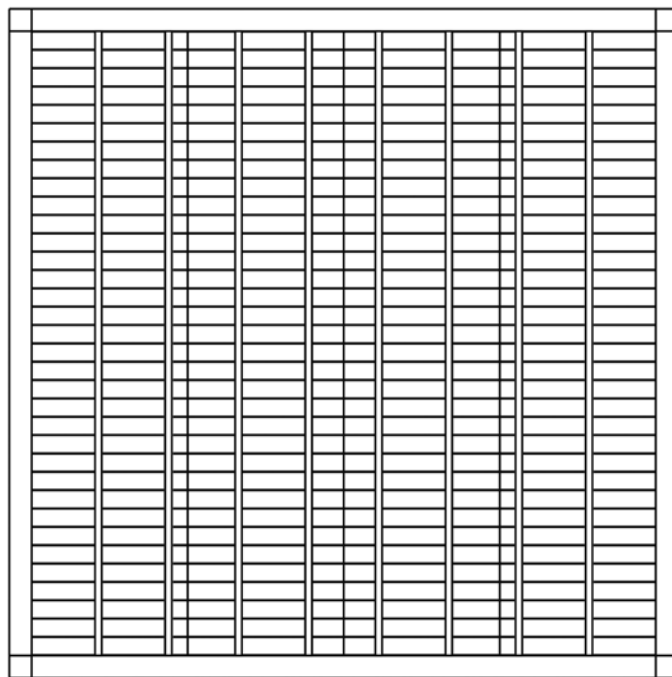

300

Note:

A richiesta possono essere aggiunti brise soleil e/o posizionati diversamente.

More panels can be added and/or mounted differently on request.

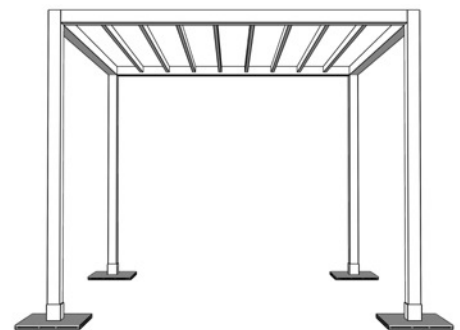
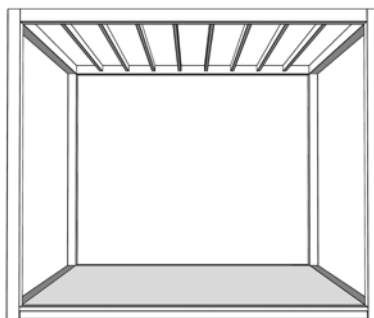
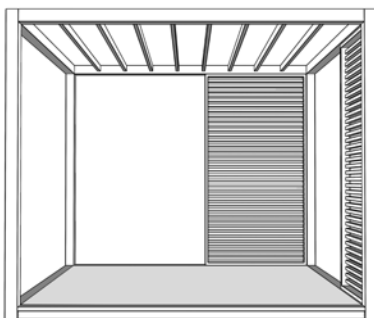

1 x STTR0807 1 x STTR0809
1 x STTR0808 1 x STTR0814

1 x STTR0807
1 x STTR0808

1 x STTR0807
1 x VENE0849-GBI

SAVANA

design by CRS SILAT

Realizzata in massello di Teak, è una collezione di sedute e tavolini da esterno con una linea discreta e funzionale. I tavoli bassi sono disponibili anche con doppio ripiano. I divani e le poltrone sono forniti con ampi cuscini sfoderabili in tessuto acrilico da esterno. Gli sgabelli alti, disponibili con o senza schienale, sono minimali e lineari nella forma e comodissimi nell'utilizzo, così come le sedie sdraio pieghevoli. Il legno è proposto in finitura a levigatura fine naturale.

A collection of solid Teak chairs and tables for outdoor use with an understated, functional design. The low tables are also available with double top. The cushions of the sofas and chairs are fully removable and made of acrylic fabric suitable for outdoor use. The high stools, available with or without backrests, are minimal and linear in shape and comfortable to use as well as the folding deck chairs. Fine Sanded is the standard finishing.

- | | |
|------------------|------------------|
| SAVA0208 → p.134 | SAVA0430 → p.136 |
| SAVA0209 → p.134 | SAVA0431 → p.136 |
| SAVA0210 → p.136 | SAVA0432 → p.136 |
| SAVA0226 → p.134 | SAVA0433 → p.140 |
| SAVA0307 → p.138 | SAVA0434 → p.140 |
| SAVA0329 → p.138 | SAVA0435 → p.140 |
| SAVA0333 → p.134 | SAVA0436 → p.140 |
| SAVA0334 → p.138 | SAVA0456 → p.140 |
| SAVA0335 → p.138 | SAVA0458 → p.136 |
| SAVA0336 → p.136 | SAVA0467 → p.138 |
| SAVA0339 → p.138 | SAVA0512 → p.142 |
| SAVA0406 → p.140 | SAVA0513 → p.142 |
| SAVA0427 → p.138 | SAVA0837 → p.136 |
| SAVA0428 → p.138 | |

SAVA0208



SAVA0209



SAVA0333



SAVA0226



SAVA0208

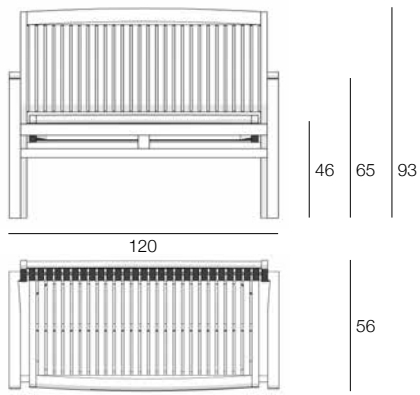

SAVA0209

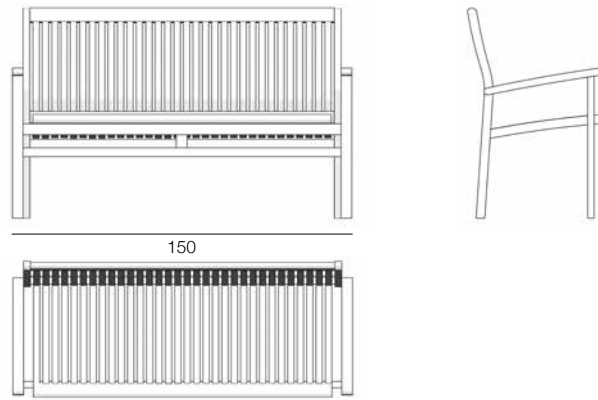

SAVA0333

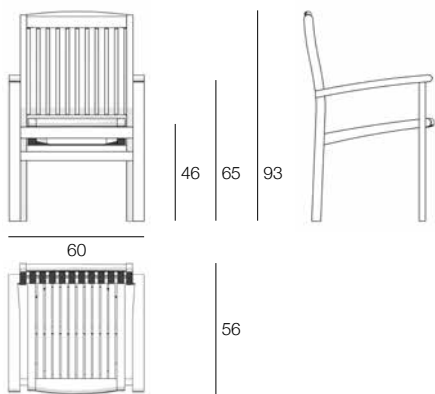

SAVA0226

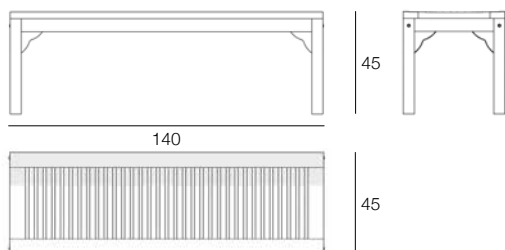

SAVA0210 + SAVA0210-CUS



SAVA0336 + SAVA0336-CUS



SAVA0837 + SAVA0837-CUS



SAVA0458



SAVA0430



SAVA0431



SAVA0432



SAVA0210

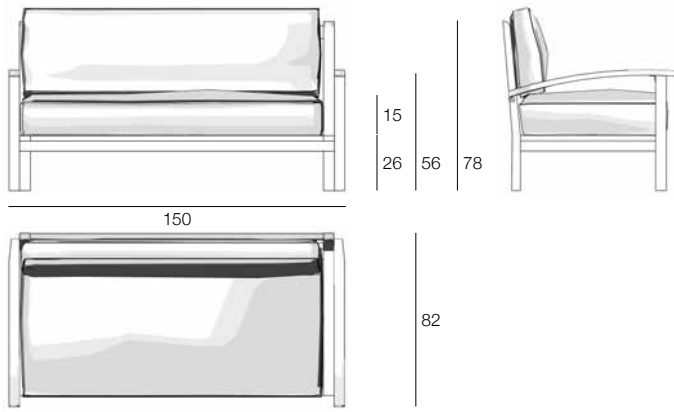

SAVA0336

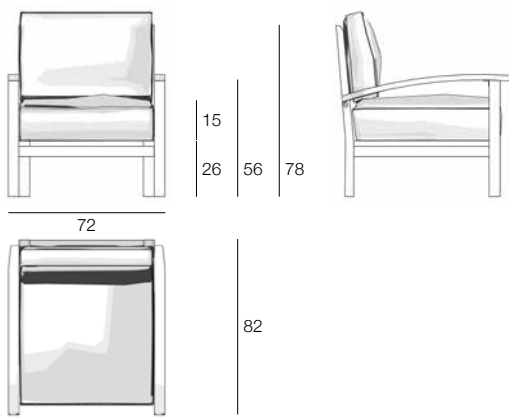

SAVA0837

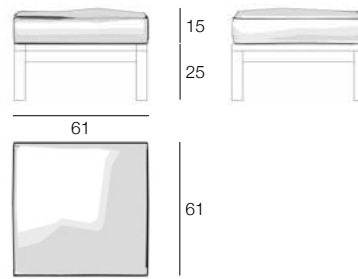

SAVA0458

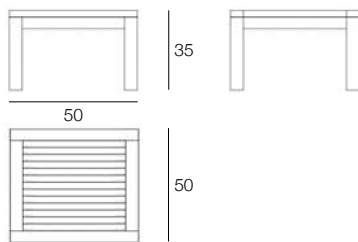

SAVA0430

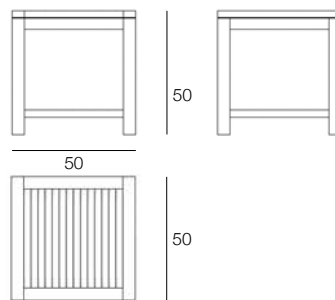

SAVA0431

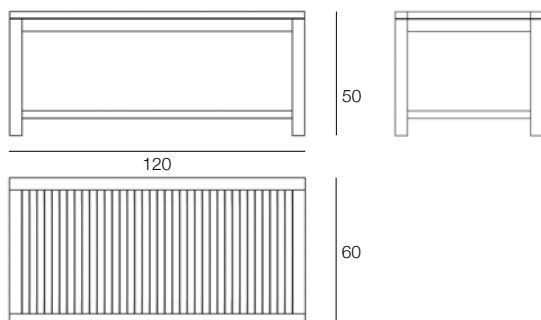

SAVA0432

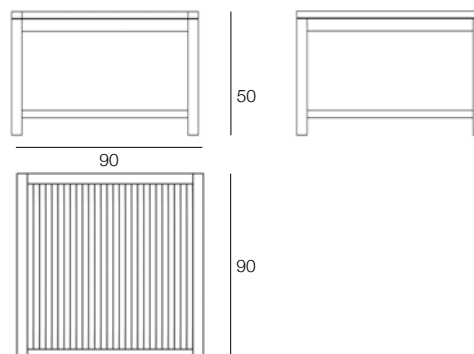

SAVA0307



SAVA0329



SAVA0334



SAVA0335



SAVA0339



SAVA0339 + SAVA0339-CUS



SAVA0427



SAVA0428



SAVA0467



SAVA0307

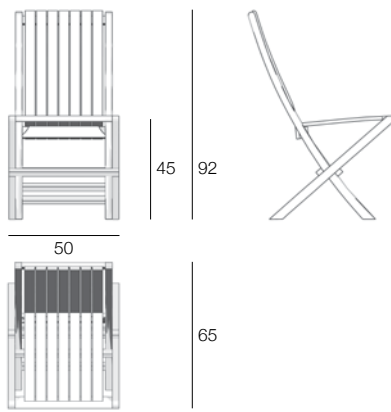

SAVA0329

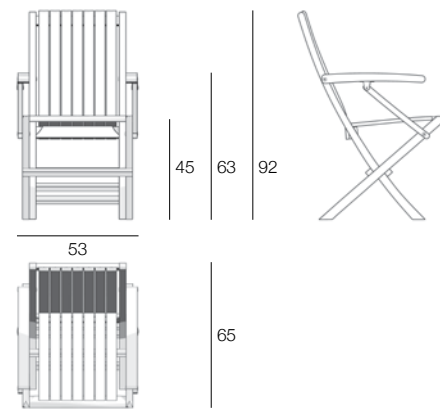

SAVA0334

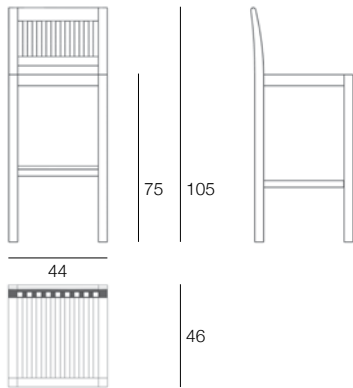

SAVA0335

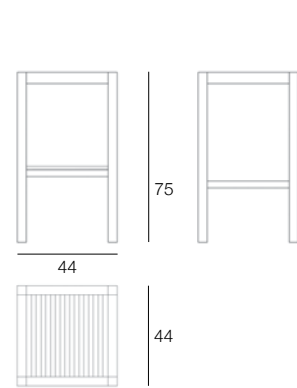

SAVA0339

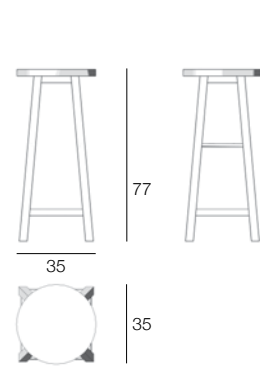

SAVA0427

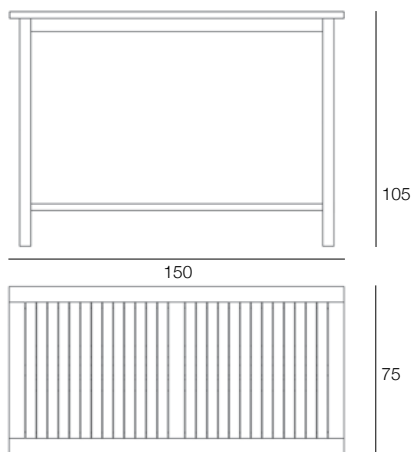

SAVA0428

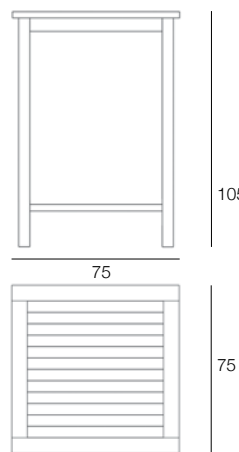

SAVA0467

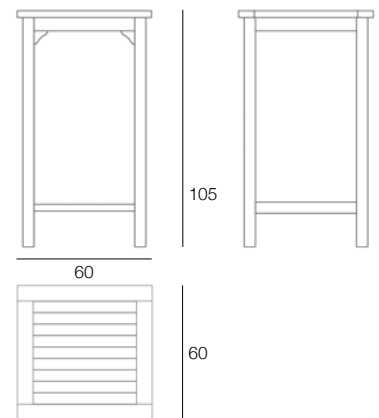

SAVA0433



SAVA0434



SAVA0406



SAVA0456



SAVA0435



SAVA0436



SAVA0433

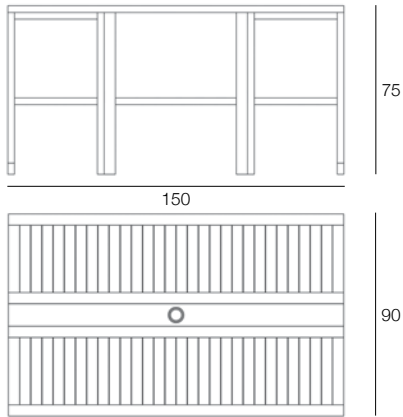

SAVA0434

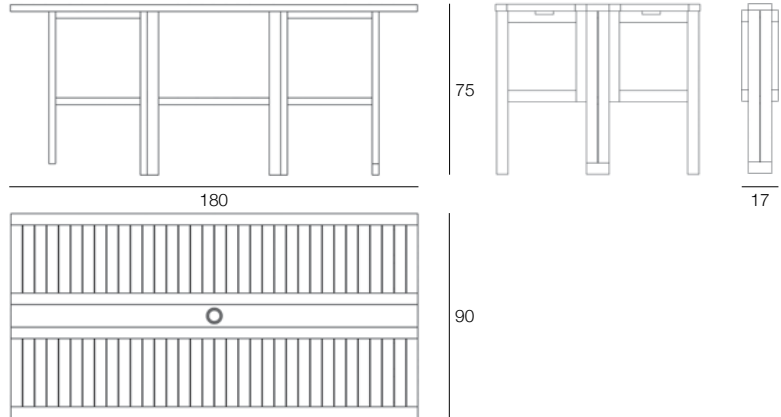

SAVA0406

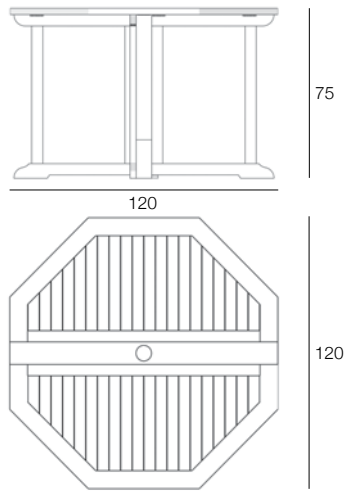

SAVA0456

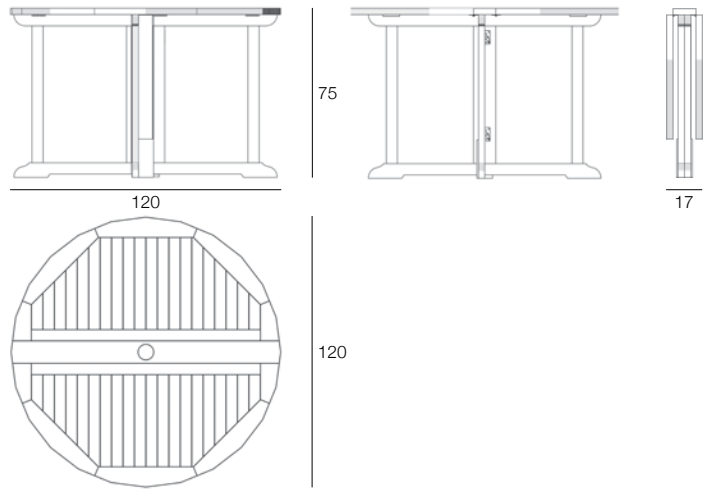

SAVA0435

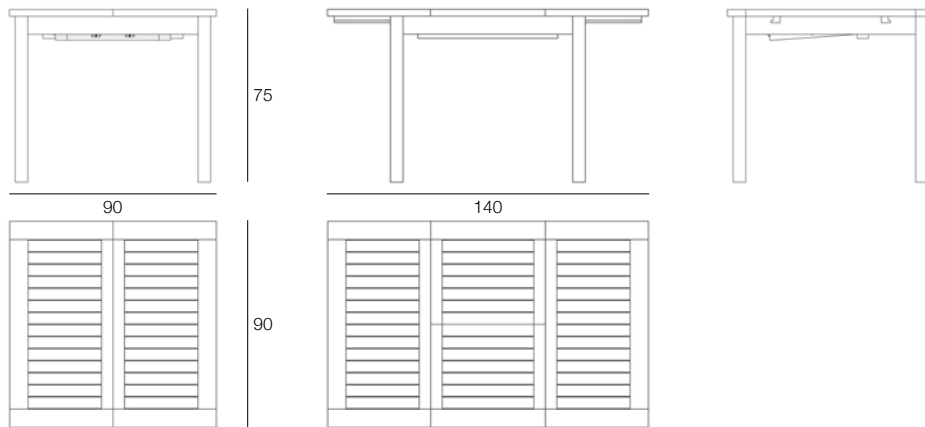

SAVA0436

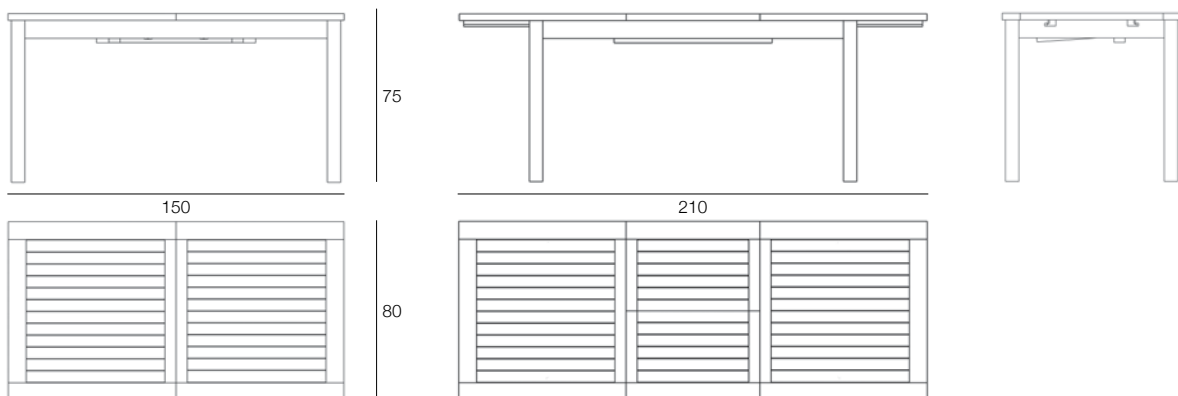

SAVA0512 + SAVA0512-CUS



SAVA0512



SAVA0513 + SAVA0513-CUS



SAVA0513



SAVA0512

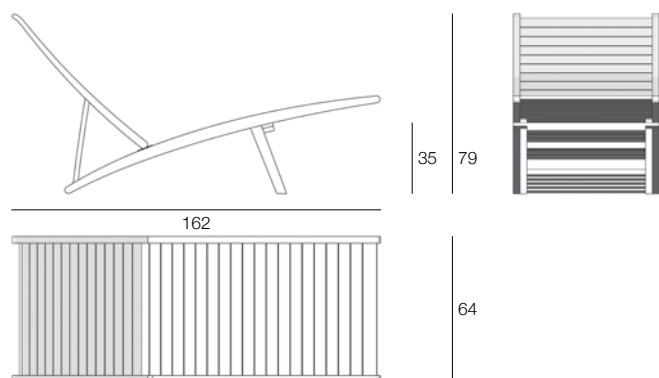

SAVA0513

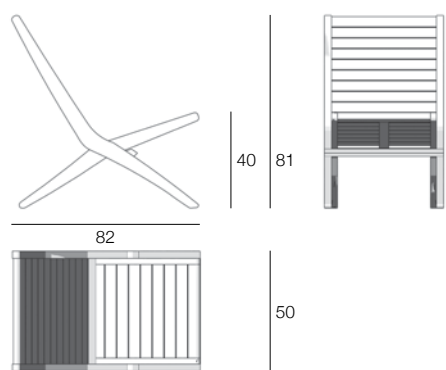

SAVA0513

SENTOSA

design by CRS SILAT

Struttura in alluminio vergine ed intreccio in fibra estrusa di polietilene ad alta densità. Divano, poltrone e letto da giorno completati da cuscini in gommapiuma protetta da fodera interna e rivestiti in tessuto acrilico. Tavolo da pranzo e sedia impilabile con struttura in legno di Teak. Sovra-piano in vetro disponibile su richiesta. Proposto in colore Banana Leaf.

Virgin aluminium frame woven with high-density extruded polyethylene fibre. Sofa, armchairs and daybed are fitted with foam cushions with internal protective lining and removable acrylic fabric cover. Dining tables and stackable chairs with Teak wood frame. Glass top available on request. Standard colour is Banana Leaf.

SENT4212 + SENT4212-CUS



SENT4311 + SENT4311-CUS



SENT4427



SENT4427 + SENT4427-GLS



SENT4312 + SENT4312-CUS



SENT4419



SENT4419 + SENT4419-GLS



SENT4212

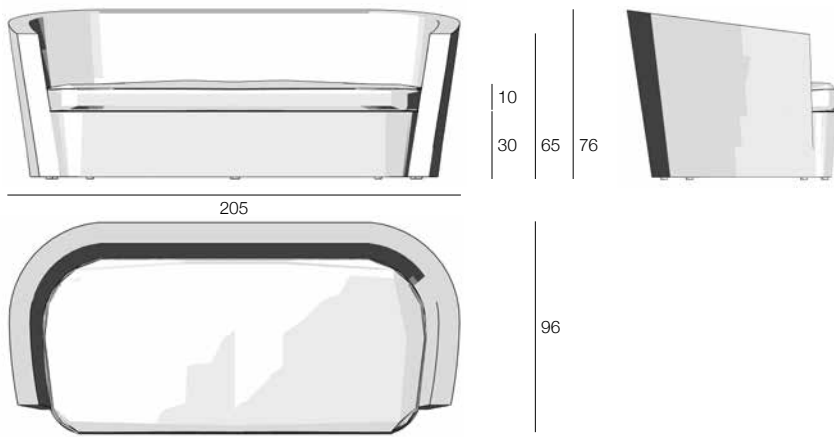

SENT4311

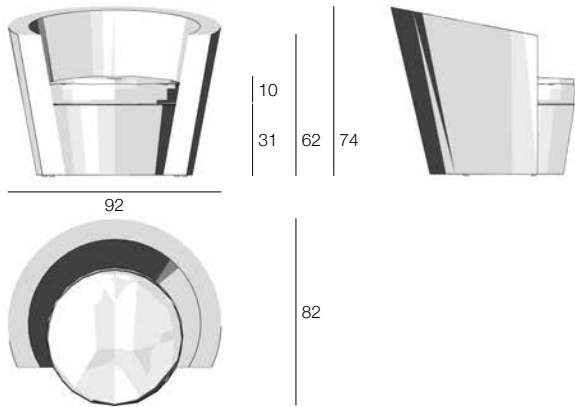

SENT4419

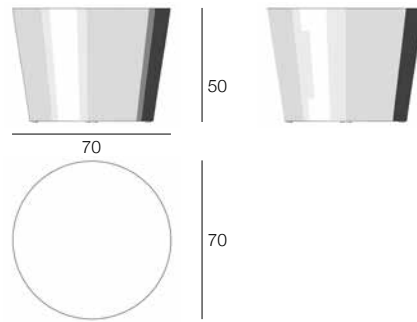

SENT4427

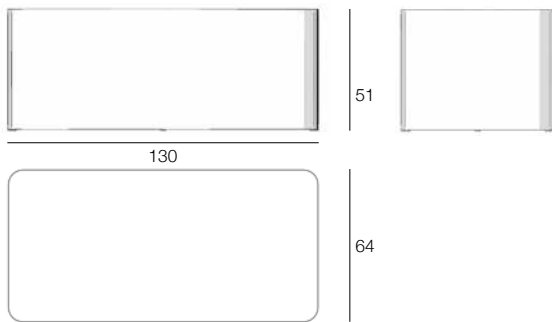

SENT4312

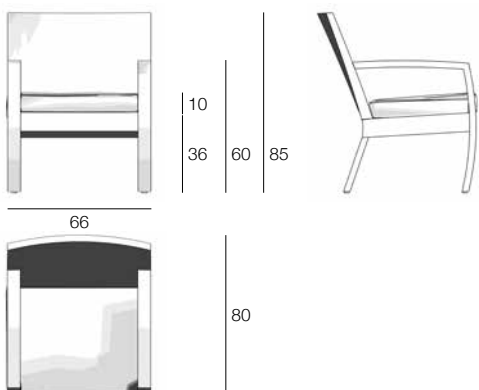

SENT4313



SENT4418



SENT4701 + K01



SENT4701 + K02



SENT4313

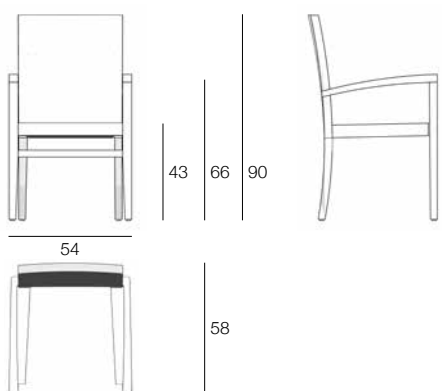

SENT4418

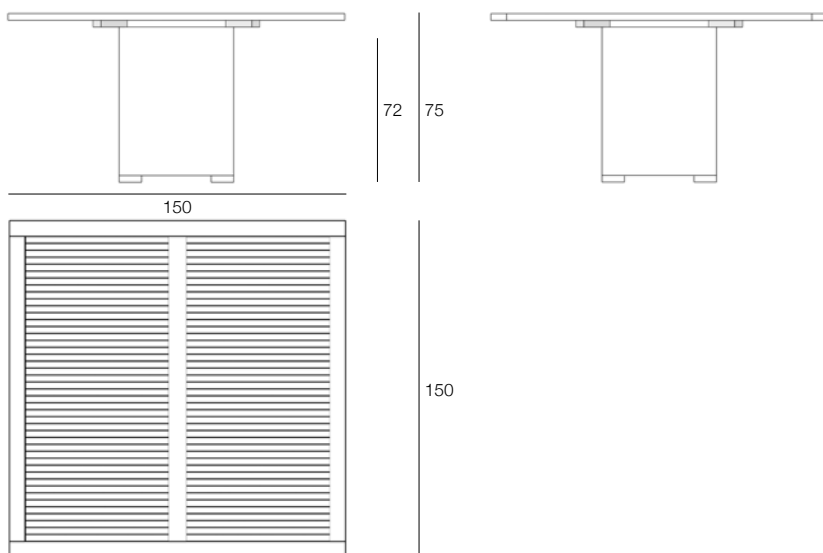

SENT4701 + K01

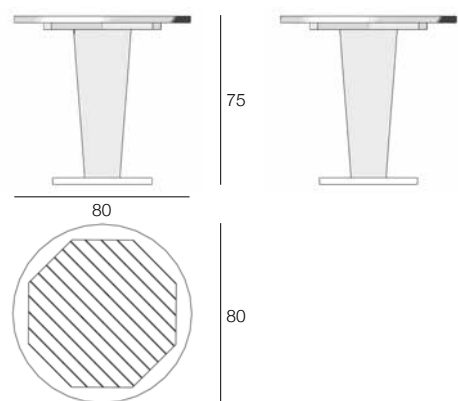

SENT4701 + K02

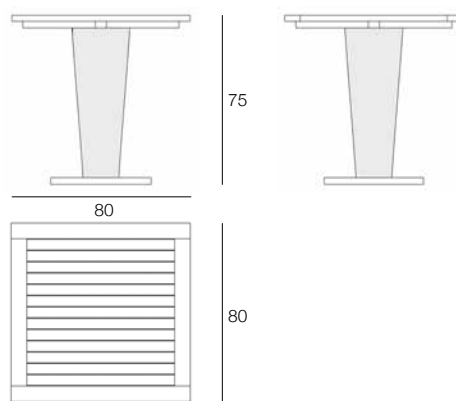

SENT4509 + SENT4509-CUS



SENT4420



SENT4421



SENT4422



SENT4512



SENT4509

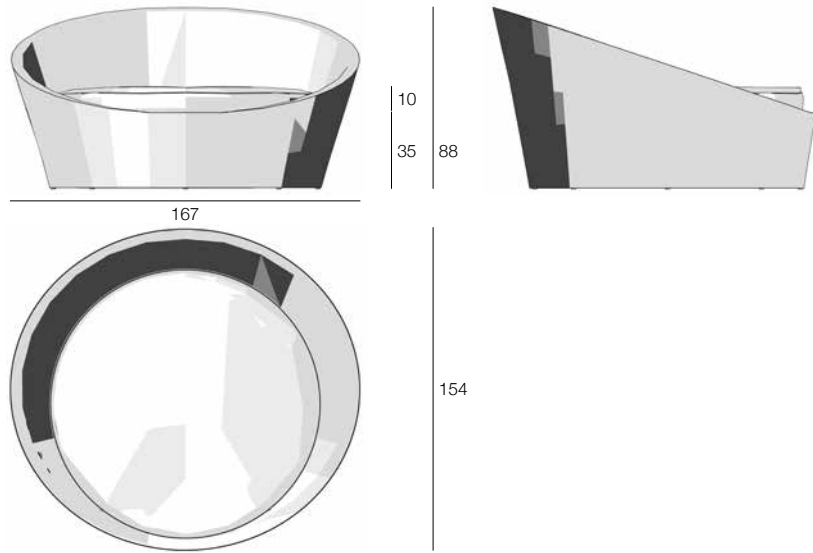

SENT4420

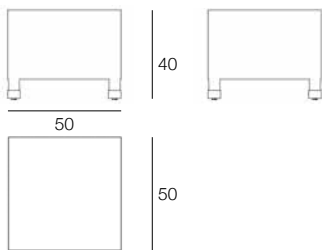

SENT4421

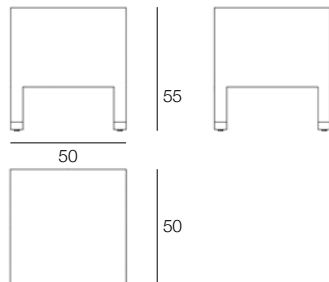

SENT4422

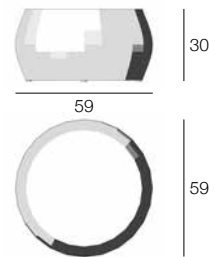

SENT4512

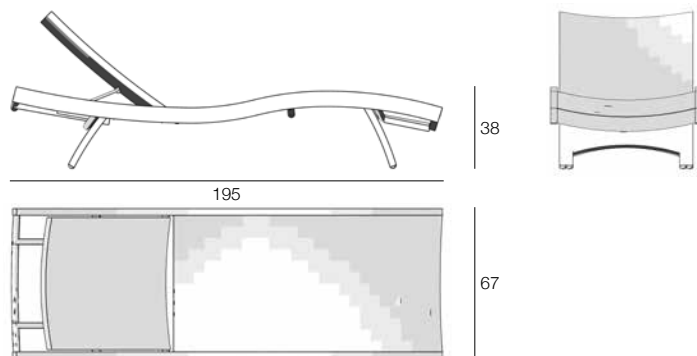

SUAR

design CAMILLA LAPUCCI E LAPO BIANCHI LUCI

La collezione Suar esalta gli spessori del legno massello con una struttura slanciata, caratterizzata da braccioli e schienali dai tagli diagonali. La linea comprende panche in tronco, divano e poltrone, letti da esterno, elementi compositivi, tavolini e pouf, oltre a tavoli di grandi dimensioni creati con piani in un unico taglio di legno massello di Suar. La finitura oliata è la finitura standard per questo tipo di legno.

Suar collection enhances the thickness of solid wood with a linear design, featured by diagonal cut armrests and backrests. The collection includes log bench, sofa and lounge chairs, outdoor beds, compositional elements, tables and ottomans, and tables made out of a single slice of solid Suar wood. Oiled finishing.

SUAR0201



SUAR0202



SUAR0202



SUAR0201

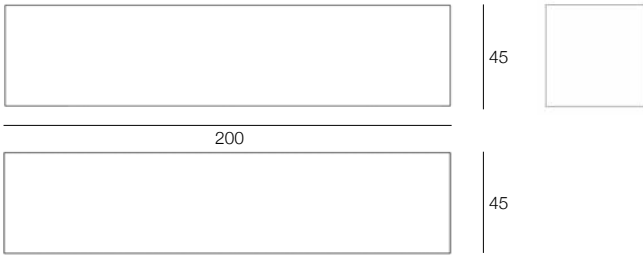

SUAR0202

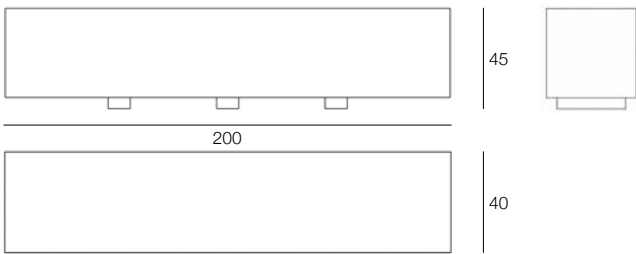

SUAR0201





1 X SUAR0203 + SUAR0203-CUS + PILW6035
1 X SUAR0404

SUAR0203 + SUAR0203-CUS



SUAR0204 + SUAR0204-CUS



SUAR0404



SUAR0203

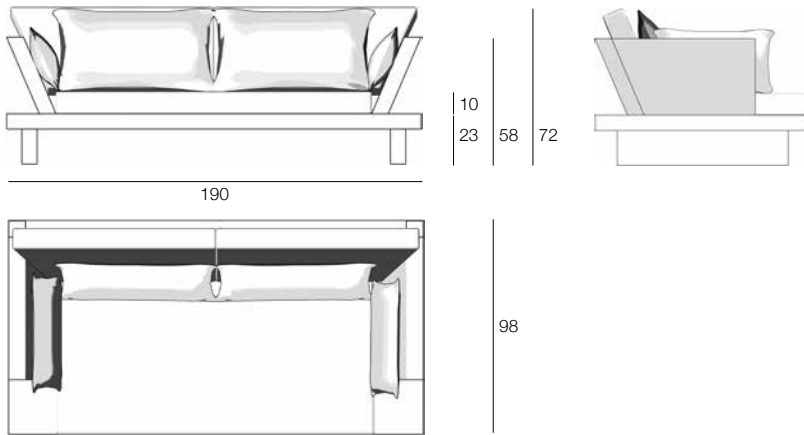

SUAR0204

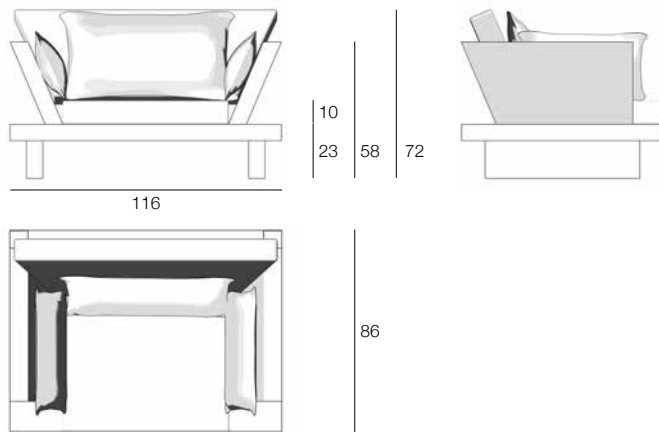

SUAR0404

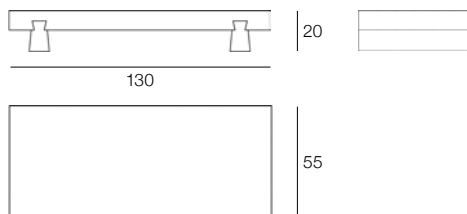

3 X SUAR0301 + SUAR0301-CUS
1 X SUAR0401



SUAR0301 + SUAR0301-CUS

SUAR0301



SUAR0402



3 X EMIL4322
1 X SUAR0401



SUAR0401

SUAR0401



SUAR0301

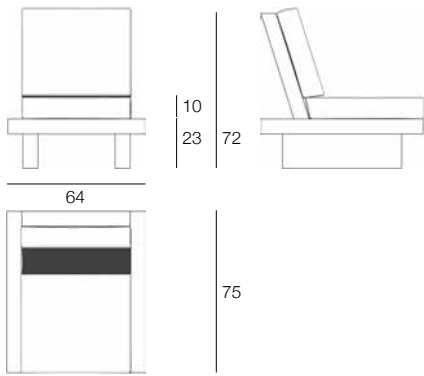

SUAR0402

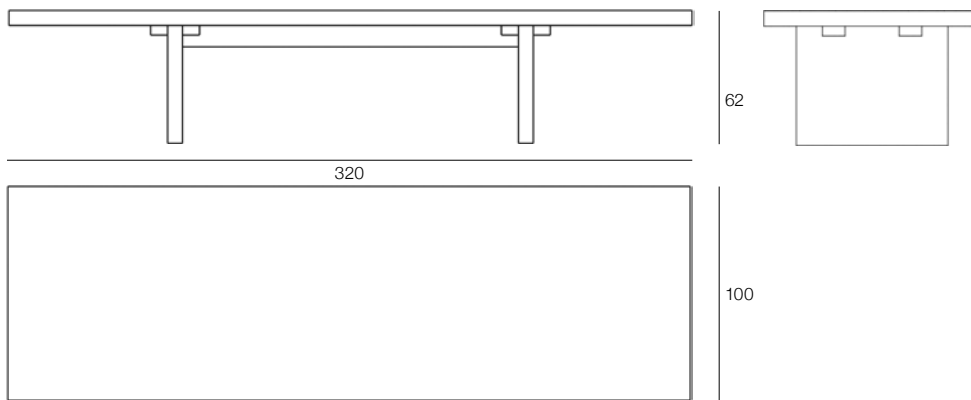

SUAR0401

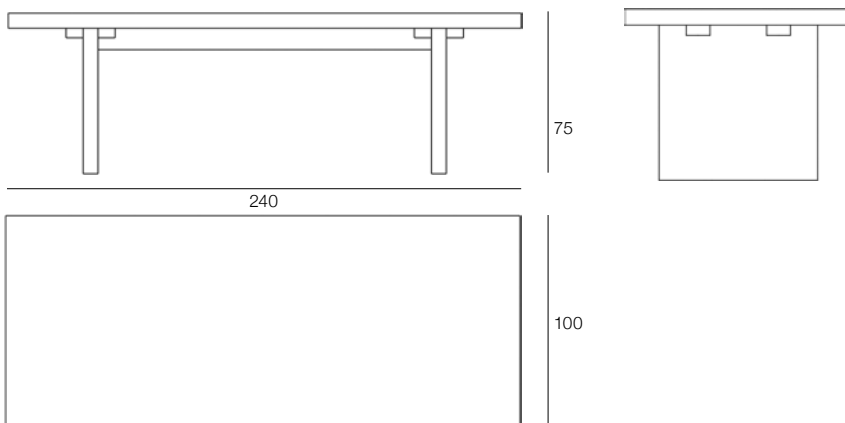

SUAR0407



SUAR0408



SUAR0472



SUAR0473



SUAR0410



SUAR0411



SUAR0412



SUAR0413



SUAR0414



SUAR0481



SUAR0501 + SUAR0501-CUS



SUAR0502 + SUAR0502-CUS



SUAR0407

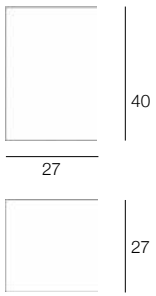

SUAR0408

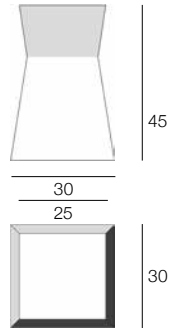

SUAR0472

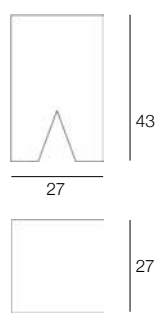

SUAR0473

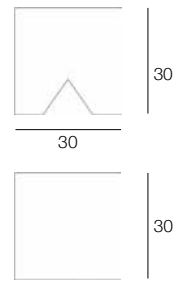

SUAR0481

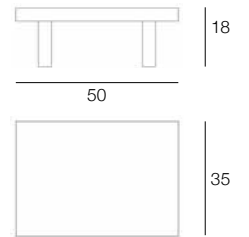

SUAR0410

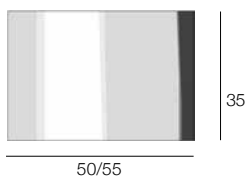

SUAR0411

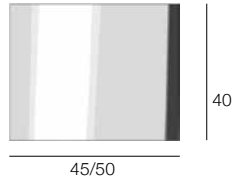

SUAR0412

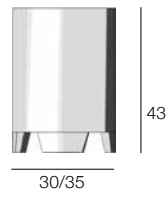

SUAR0413

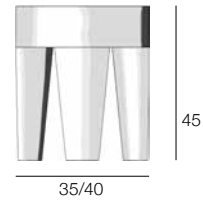

SUAR0414

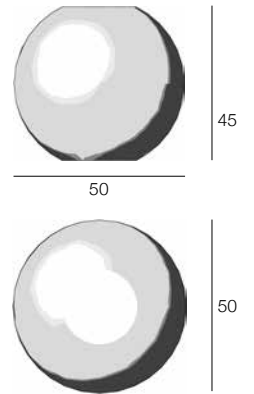

SUAR0501

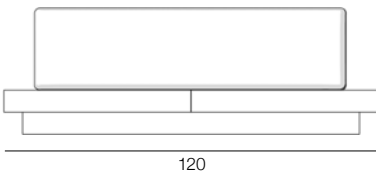

SUAR0502

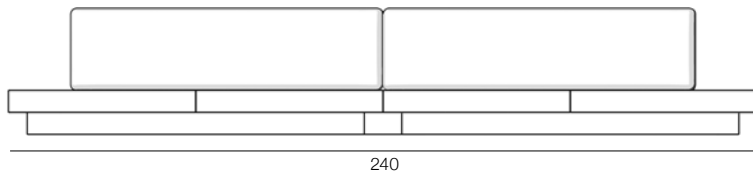

26
14

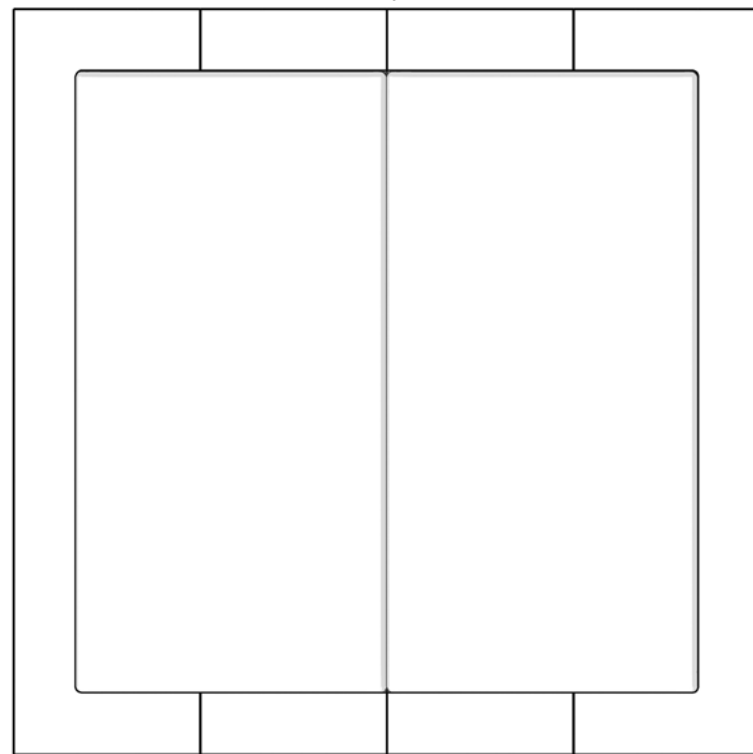
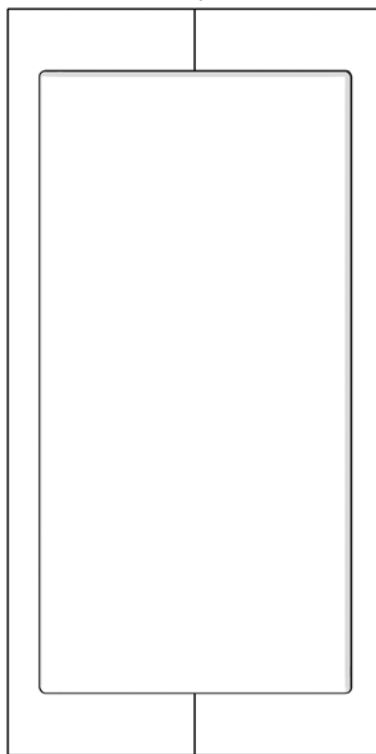

240 200

100

100

100

SUAR0862



SUAR0405



SUAR0406



SUAR0403



SUAR0403



SUAR0862

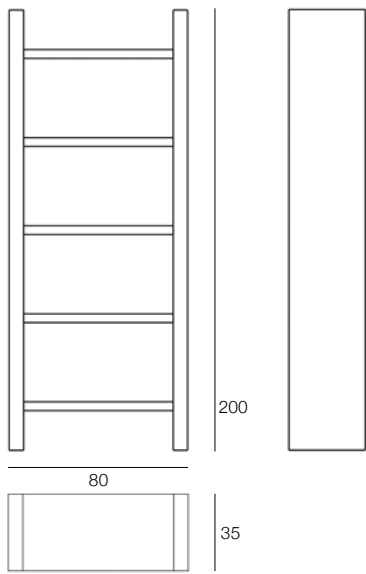

SUAR0405

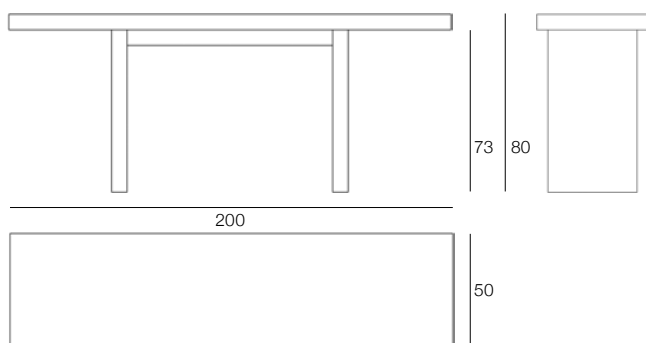

SUAR0406

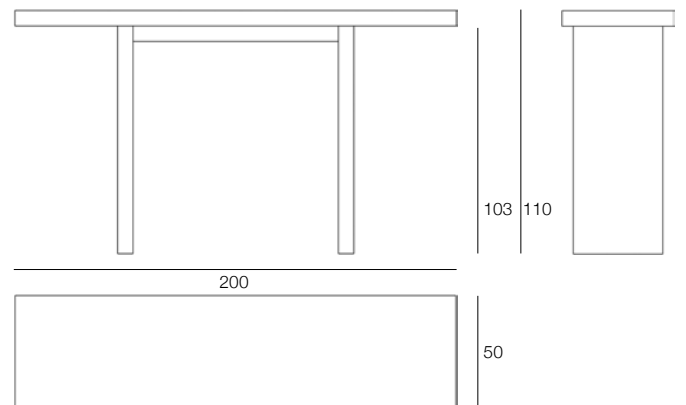

SUAR0403

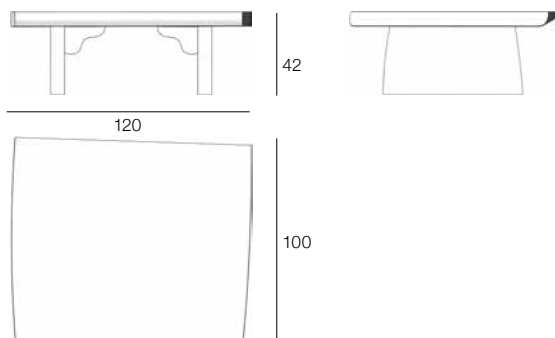

TILES

design by CRS SILAT

Pavimentazione a quadrotti in legno di Teak. Disponibili nella misura 30x30cm con base in PVC ed incastro maschio-femmina che mantiene le piastrelle solidali tra loro. Oppure nella misura 50x50cm con base in Teak. Drenanti e di facile posa: possono essere appoggiati direttamente sulla pavimentazione esistente, su un battuto di cemento o direttamente sul terreno. I pavimenti sono realizzati con legno di Teak che proviene dai resti di taglio della lavorazione dei mobili da esterno. Quindi nessun albero è stato abbattuto per la realizzazione di questi pavimenti: belli, durevoli, originali e del tutto eco-compatibili. Il legno è proposto in finitura a levigatura fine naturale.

Teak flooring tiles. Available in 30x30cm size with PVC backing and male-female interlock which ensures that the tiles perfectly fit together. Or in 50x50cm size with Teak backing. Water runoff and easy to lay: can be laid directly on existing flooring or on a cement slab or even directly on the ground. Tiles for flooring are made of Teak wood coming from the cut wastage of the outdoor furniture production, so that no trees were cut for the construction of these beautiful, durable, original and completely eco-friendly floors. Fine Sanded is the standard wood finishing.

TILT2502



50 x 50 cm

TILT2501



50 x 50 cm

TILT2301



TILT2303



30 x 30 cm

TILT2501
OTTO0301

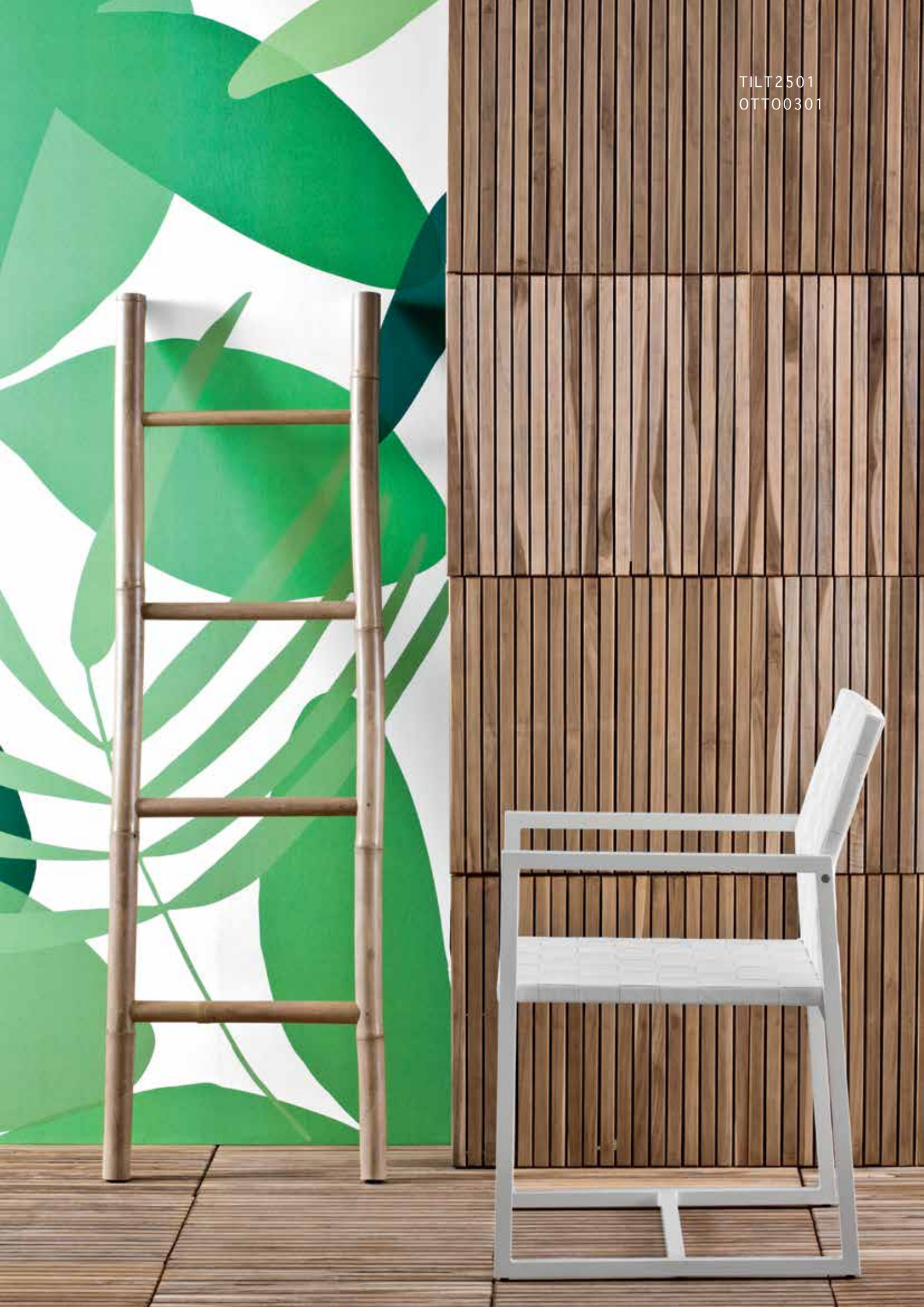

TONGA

design by CRS SILAT

Intreccio in HDPE Peel da 6mm su una struttura in alluminio vergine. Le sedie e le poltroncine sono impilabili, i cuscini sono realizzati in gommapiuma protetta e rivestita con tessuto acrilico sfoderabile. I tavoli da pranzo ed i tavoli alti da bar hanno il piano in vetro a finitura satinata. I tavoli bassi hanno un doppio piano in listelli di legno di Teak. I lettini da sole sono dotati di ruote in Teflon con cuscinetti a sfera, ideali per il bordo piscina. Personalizzazioni per posizionamento in spiaggia da effettuarsi su richiesta. Braccioli in Teak. Proposto in fibra sintetica colore White Wash e Teak con finitura naturale.

6mm HDPE Peel woven on virgin aluminium frame. The chairs and the lounge chairs are stackable and feature foam cushions protected and lined with removable acrylic fabric cover. The dining and high bar tables have a frosted glass top. The low tables have a double Teak wood slats top. The sun loungers are fitted with Teflon wheels with bearings, ideal for pool side use. Customisations for positioning on beach available on request. Teak armrests. The standard finishing is White Wash colour and Fine Sanded teakwood tabletops and details.

TONG4201 + TONG4201-CUS



TONG4202 + TONG4202-CUS



TONG4301 + TONG4301-CUS



TONG4403



TONG4404



TONG4201

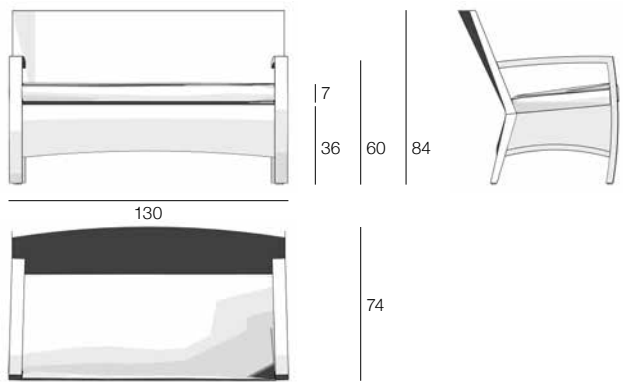

TONG4202

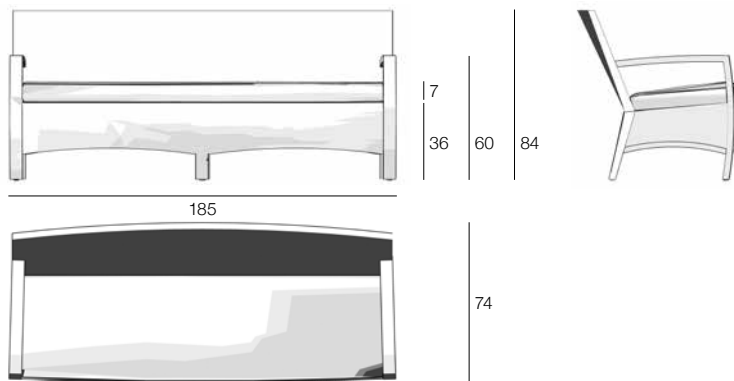

TONG4301

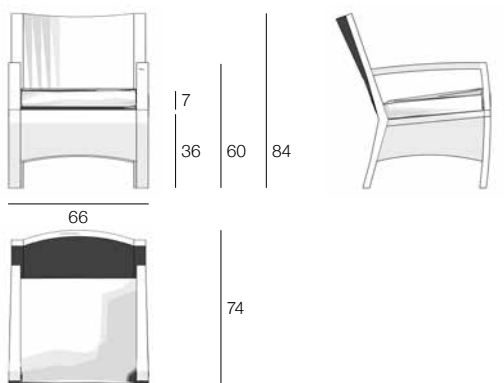

TONG4403

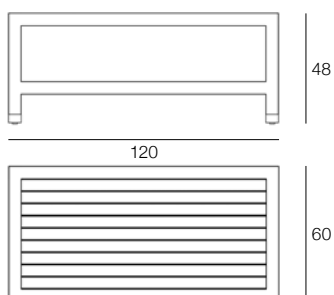

TONG4404

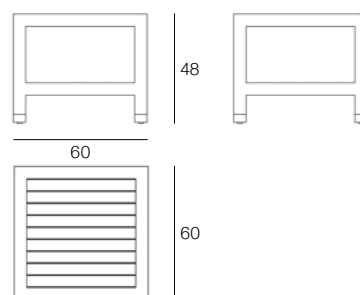

TONG4302



TONG4303



TONG4214

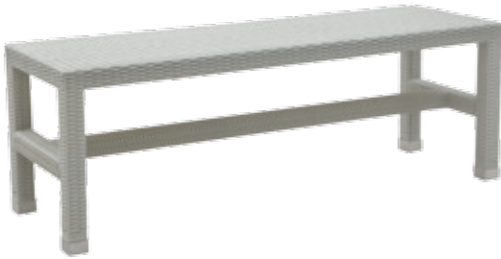

TONG4401



TONG4402

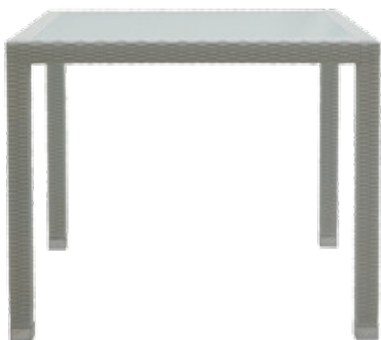

TONG4302

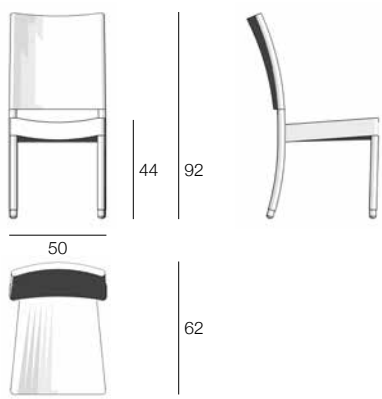

TONG4303

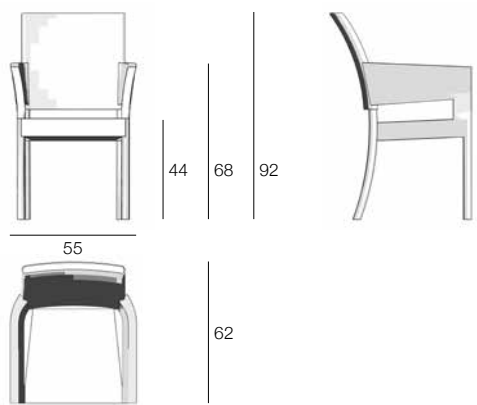

TONG4214

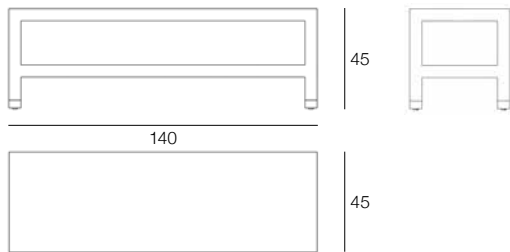

TONG4401

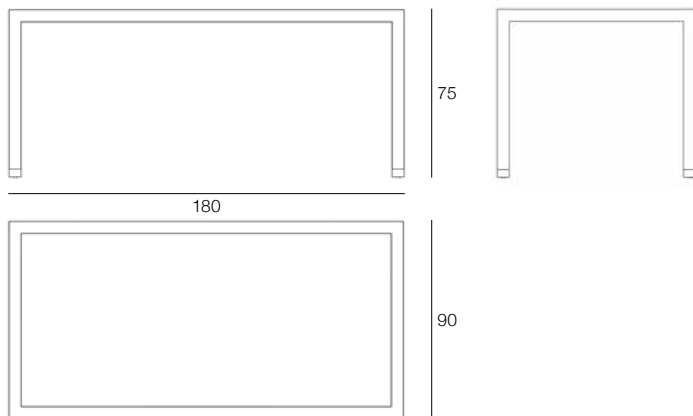

TONG4402

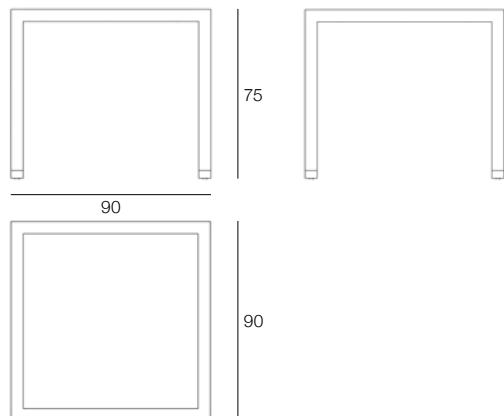

TONG4315



TONG4469



TONG4470

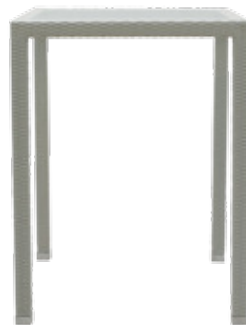

TONG4501



TONG4501 + TONG4501-CUS



TONG4502



TONG4502 + TONG4502-CUS



TONG4315

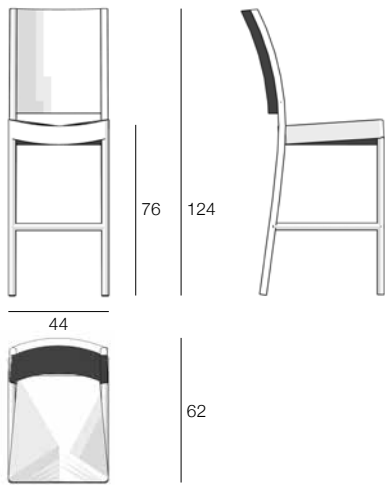

TONG4469

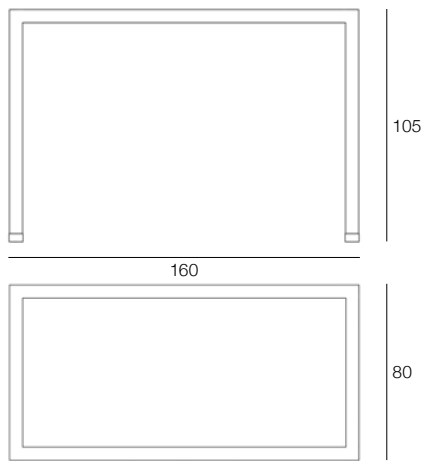

TONG4470

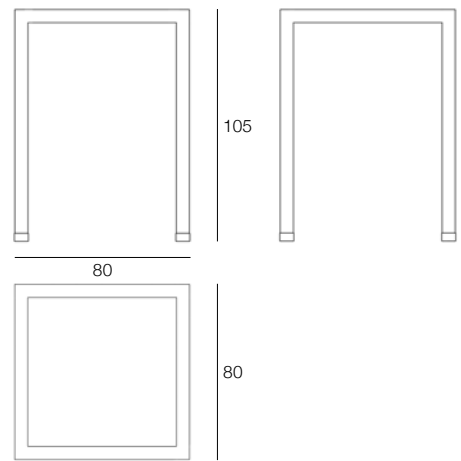

TONG4501

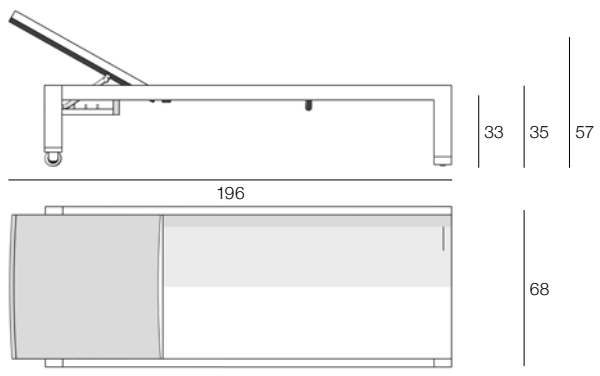

TONG4502

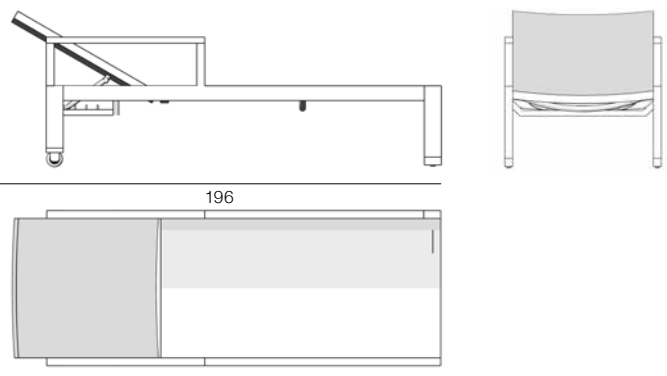

VENEZIA

design by CRS SILAT

Struttura costituita da componenti a sezione quadrata in legno di Teak e caratterizzata dall'uso della tela come componente strutturale ed estetica. I divani della serie di sedute modulari Venezia sono realizzati in massello di Teak ed i cuscini sono in poliuretano espanso con fodera di protezione e copertura in tessuto da esterno sfoderabile. Le sedie regista sono in legno di Teak con seduta e schienale in tessuto Ecrù, così come la tela della sedia tripolina che può essere richiesta in versione normale a strato singolo oppure con imbottitura. Ad eccezione dei divani l'intera collezione è costituita da elementi pieghevoli caratterizzati da ingombri minimi quando chiusi. Ferramenta in acciaio ed ottone cromato. Il legno è proposto in finitura a levigatura fine naturale.

Structure made of square section components and characterized by the use of the fabrics as a structural and aesthetic element. The Venezia sectional seating sofas are made of solid Teak and the cushions are in polyurethane foam with a removable outdoor fabric cover. The director's chairs and Tripolina deck chair have wooden structure with seat and back in ecru fabrics. The shape of canvas can be chosen from single layer or padding. Except the sofas, the whole collection is entirely composed of collapsible elements taking up very small space when folded. Hardware in stainless steel and chromed brass. The standard finishing for the Teak is Fine Sanded.

VENE0235 + VENE0235-CUS



VENE0235 + VENE0235-CUS



VENE0236 + VENE0236-CUS



VENE0237 + VENE0237-CUS



VENE0451



2 X VENE0235 + VENE0235-CUS
1 X VENE0236 + VENE0236-CUS



VENE0235

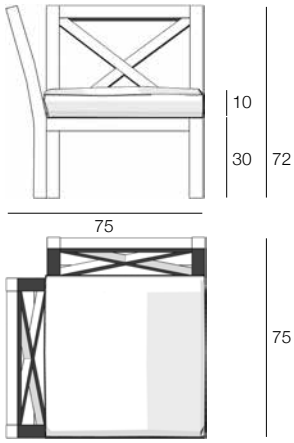

VENE0235

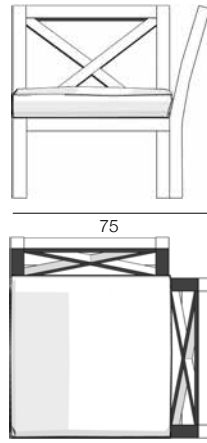

VENE0236

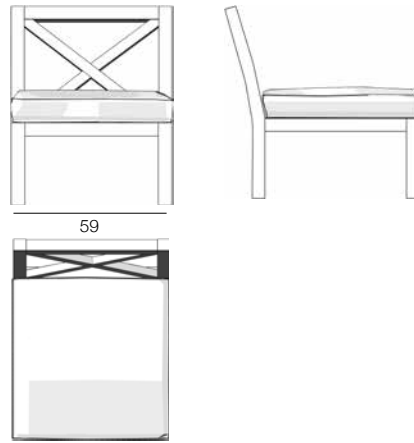

VENE0237

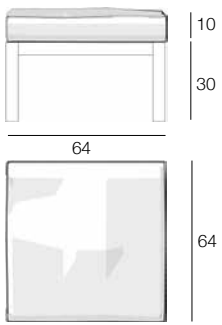

VENE0451

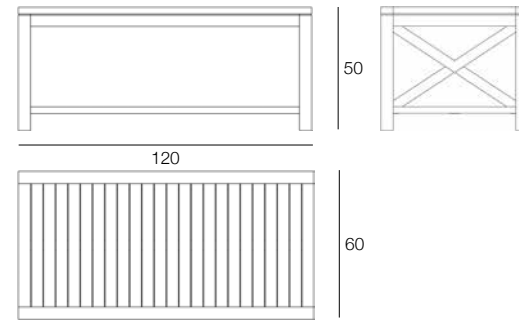

- 1 X VENE0235 + VENE0235-CUS
- 1 X VENE0236 + VENE0236-CUS
- 1 X VENE0237 + VENE0237-CUS



VENE0346 + K01



VENE0346 + K02



VENE0452



VENE0453



VENE0454



VENE0455



VENE0346

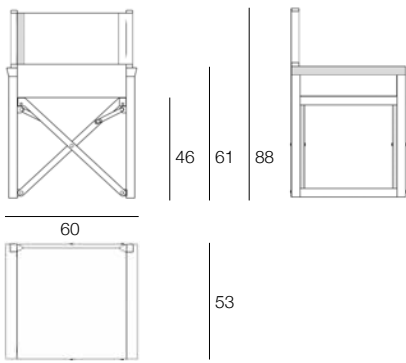

VENE0452

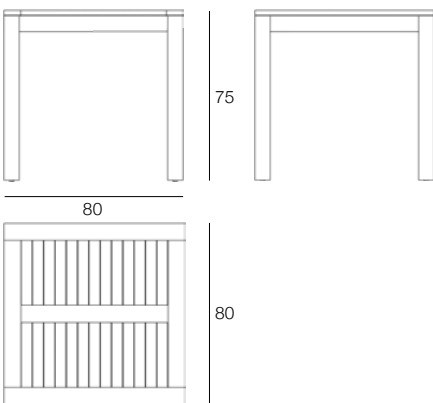

VENE0453

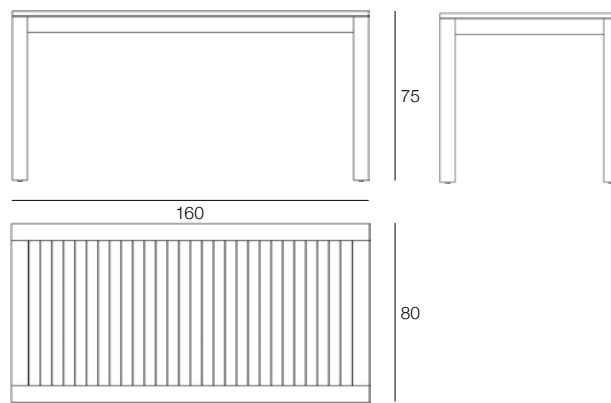

VENE0454

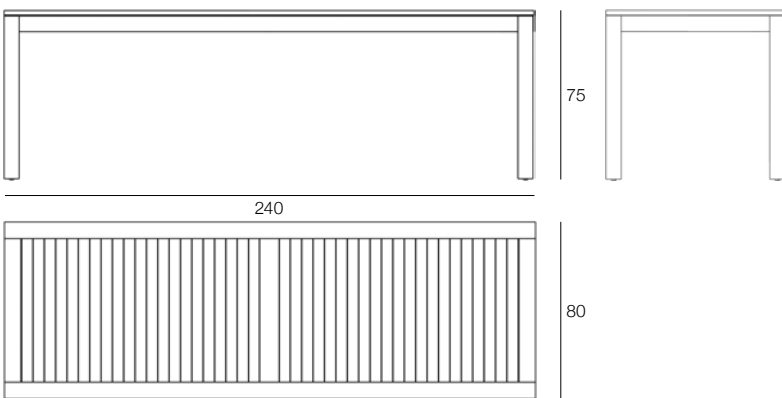

VENE0455

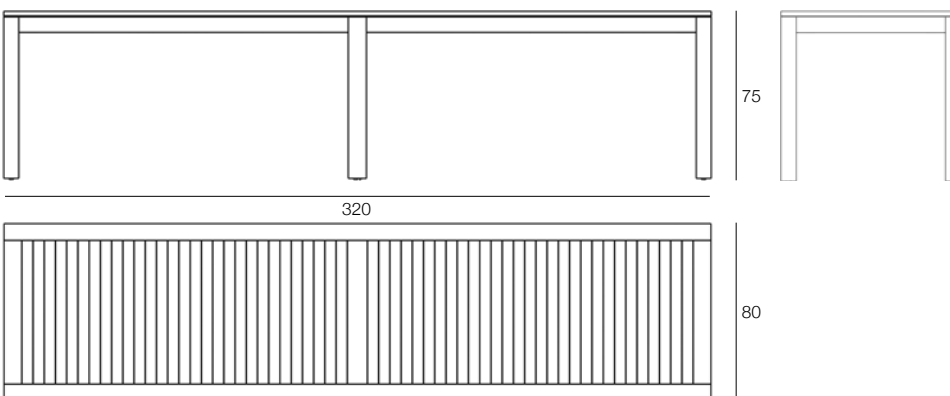

VENE0507 + K01



VENE0507 + K02



VENE0522 + K01



VENE0523 + K01



VENE0524 + K01



VENE0848



VENE0854 + K01



VENE0507

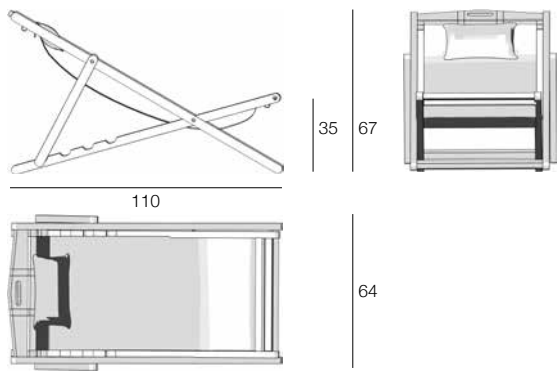

VENE0522

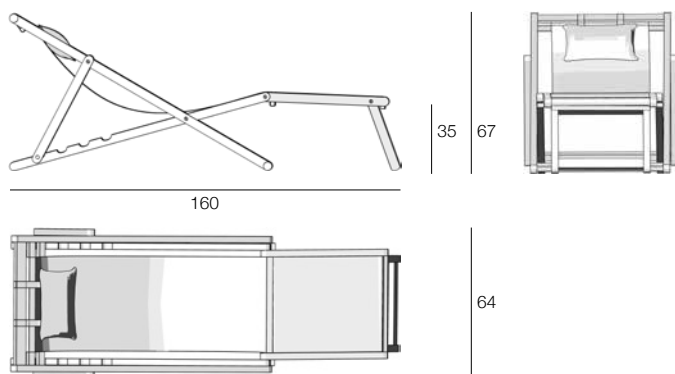

VENE0523

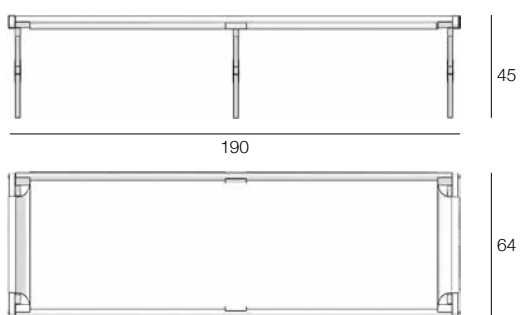

VENE0524

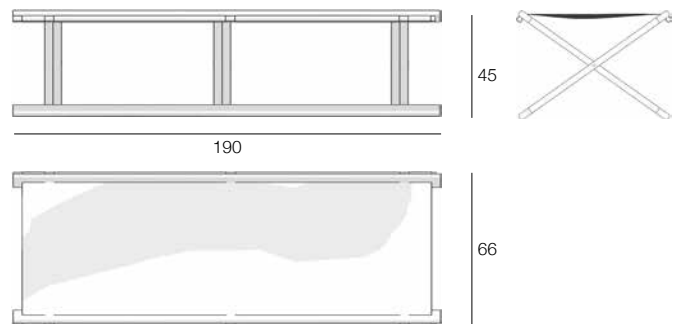

VENE0848

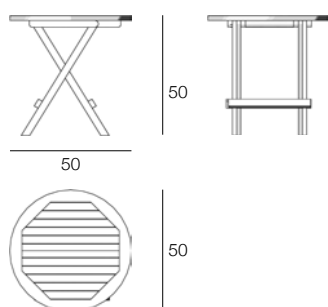

VENE0854

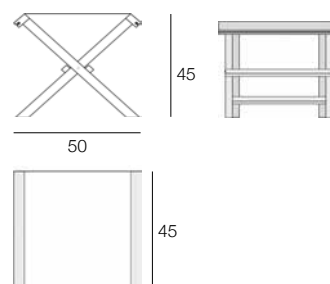

VENEZIA

TRIPOLINA

Icona assoluta nel mondo delle sedie pieghevoli, la leggendaria tripolina viene riproposta da Il Giardino di Legno in massello di Teak con tela disponibile in vari colori. Per il massimo comfort viene proposta anche con tela imbottita. Struttura in massello di Teak, ferramenta in acciaio inox e ottone cromato. Il legno è proposto in finitura a levigatura fine naturale.

The legendary butterfly chair Tripolina is a true icon in the world of folding chairs. Il Giardino di Legno has created a version made of solid Teak wood and canvas in different colours. Il Giardino di Legno presents a new padded canvas that makes it even more original, ensuring maximum comfort. Structure in solid Teak wood, hardware in stainless steel and chromed brass. Fine Sanded is the standard wood finishing.

VENE0520 + K02



VENE0520 + K01



VENE0520

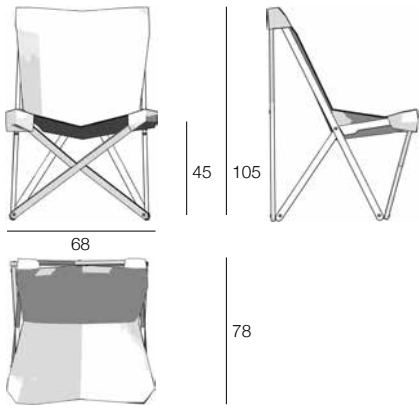

1 x VENE0849
1 x VENE0849-GBI

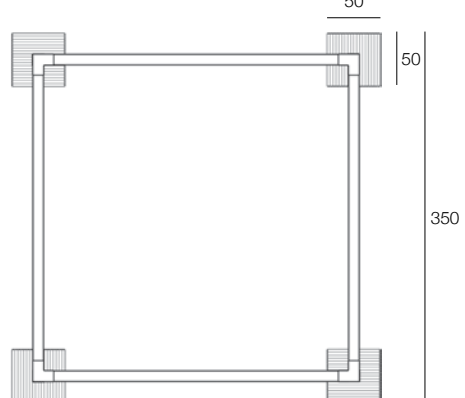
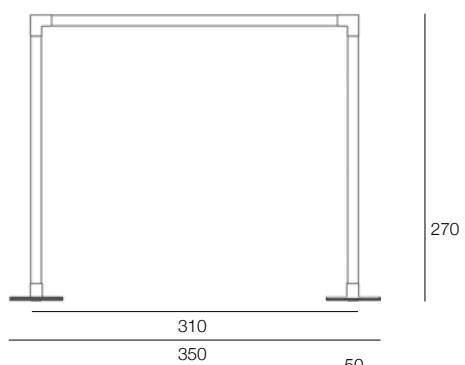

1 x VENE0849
1 x VENE0849-GBI

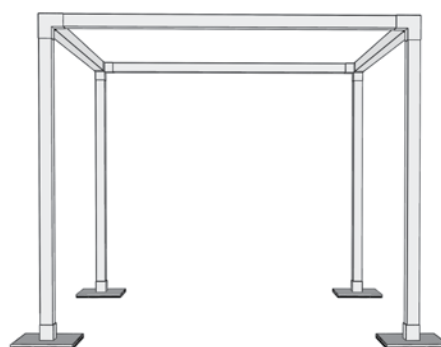

SUAR0472
SUAR0473
VENE0523



VITTORIA

design by CRS SILAT

Realizzata in massello di Teak con ferramenta in ottone. Smontabile. Dal design classico, queste sedute si ispirano alle panche ideate da Sir Edwin Lutyens a Nuova Delhi unendo l'eleganza delle linee con la resistenza del legno di Teak massello. Il legno è proposto in finitura a levigatura fine naturale.

Made of solid Teak wood with brass hardware. Demountable. Classical design inspired by the benches designed by Sir Edwin Lutyens in New Delhi, a blend of elegant styling and the strength of solid Teak wood. Fine Sanded is the standard wood finishing.

VITT0305



VITT0207



VITT0305

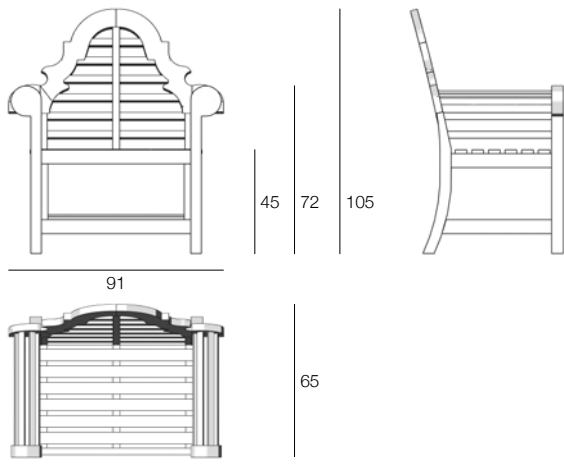

VITT0207

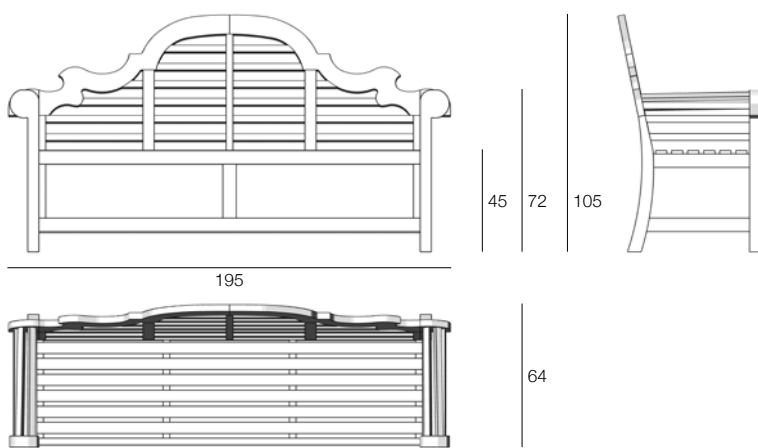

WAIKIKI

design by CRS SILAT

Realizzata in fibra sintetica HDPE Peel da 6mm intrecciata su una solida e leggera struttura in alluminio vergine. Poltroncine e sdraio impilabili. Tavoli da pranzo con piano in Teak. Divani e poltrone con cuscini in gommapiuma e Dacron, rivestiti in tessuto acrilico sfoderabile con fodera protettiva interna. Piedini in alluminio e elemento antigraffio in Teflon. Il legno è proposto in finitura a levigatura fine naturale, la fibra sintetica in colore Natural.

Made of 6mm HDPE Peel synthetic fibre woven on a light but strong virgin aluminium frame. The lounge chairs and deckchairs are stackable. Dining tables with Teak wood top. Sofas and armchairs with foam and Dacron cushions with internal protective lining and external removable acrylic fabric cover. Aluminium feet and antiscratch Teflon element. Fine Sanded is the standard wood finishing. Synthetic fibre is in Natural colour.

WAIK4204 + WAIK4204-CUS



WAIK4308 + WAIK4308-CUS



WAIK4412



WAIK4413



WAIK4310



WAIK4409



WAIK4410



WAIK4411



WAIK4204

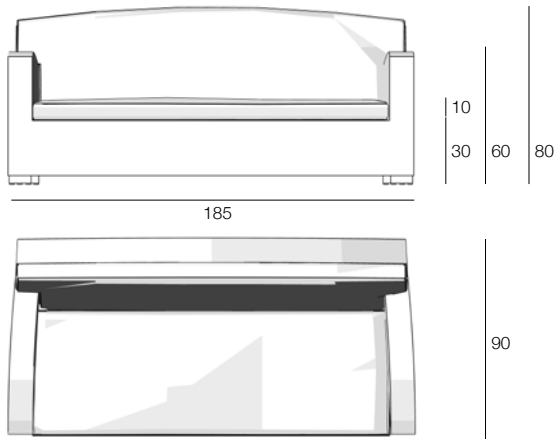

WAIK4308

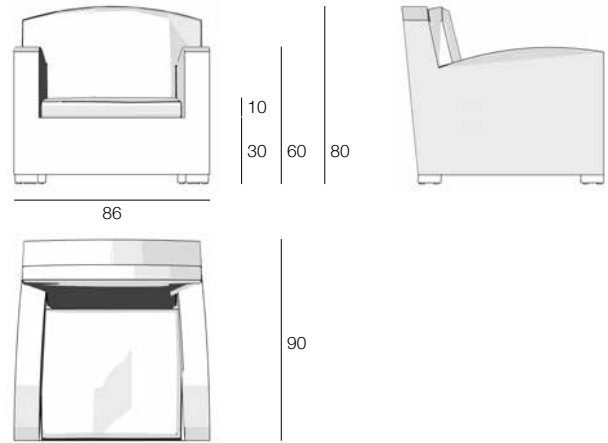

WAIK4412

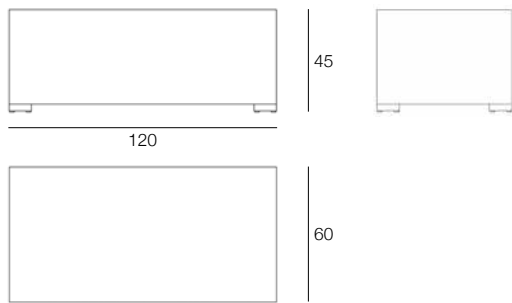

WAIK4413

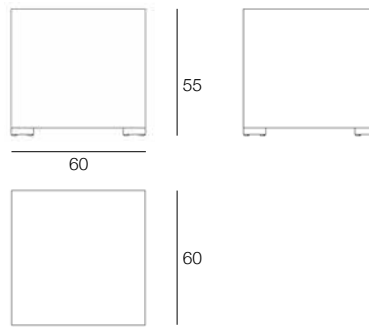

WAIK4310

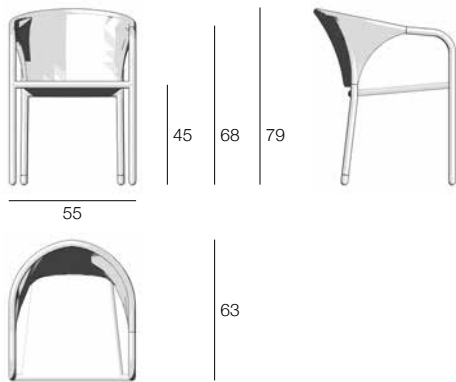

WAIK4409

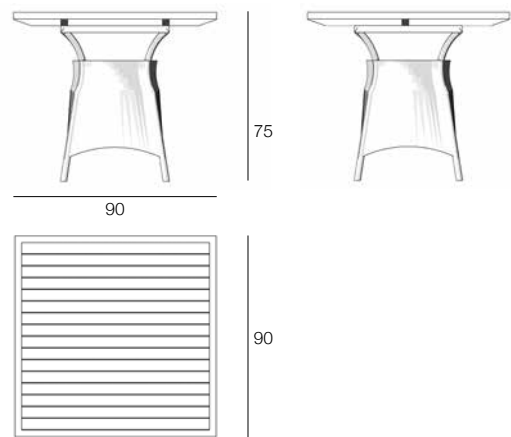

WAIK4410

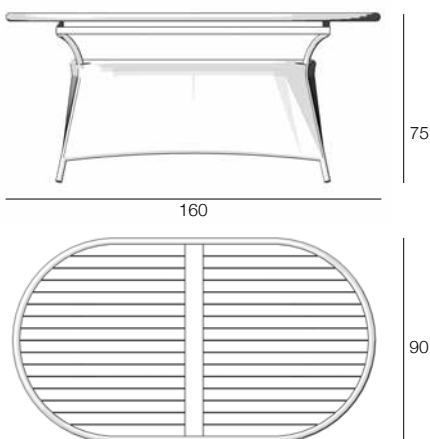

WAIK4411

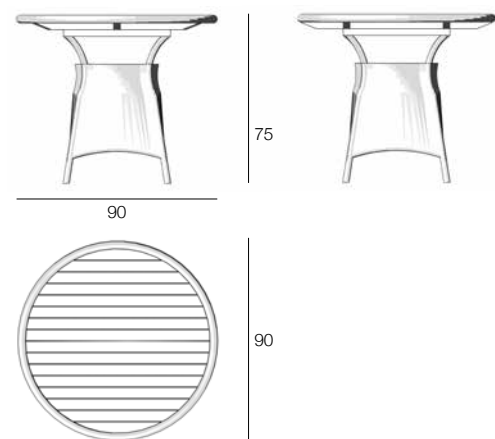

WAIK4504



WAIK4505



WAIK4508 + WAIK4508-CUS



WAIK4504

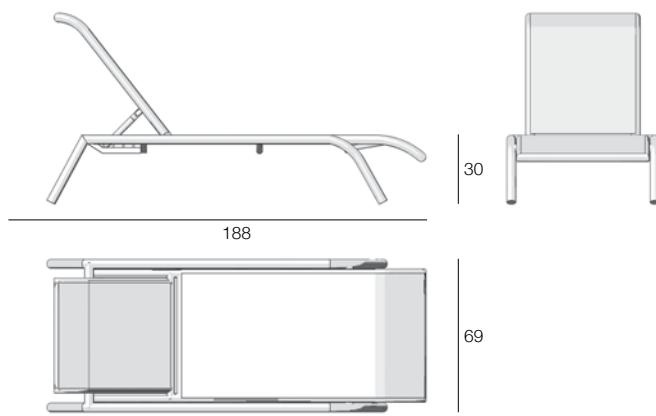

WAIK4505

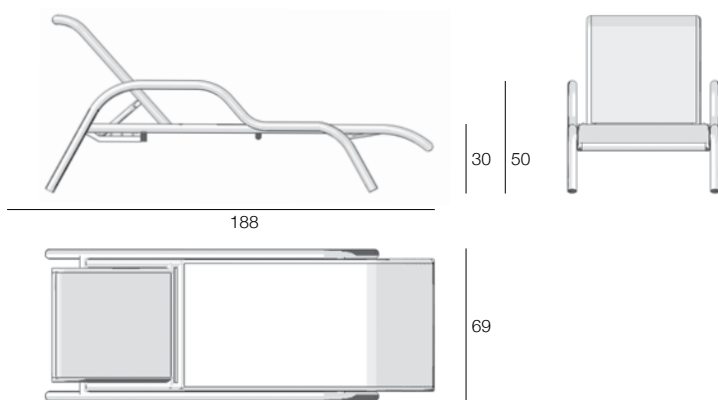

WAIK4508

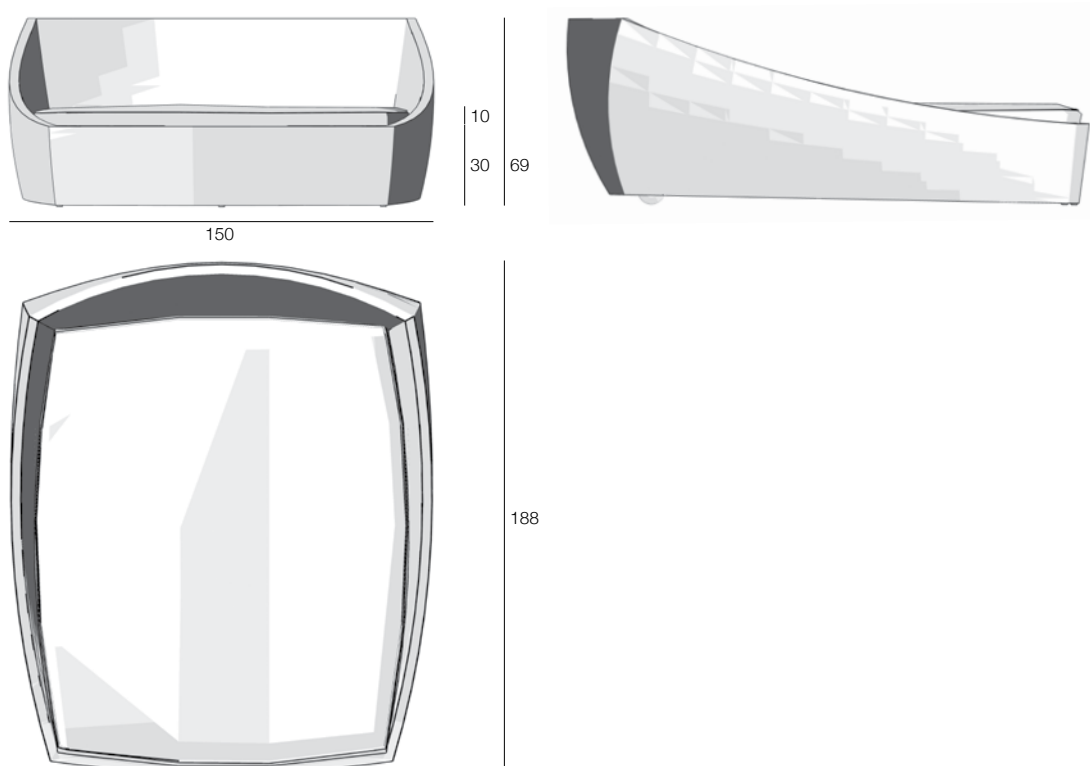

WAPITI

design by CRS SILAT

La collezione da esterno Wapiti è realizzata in fibra sintetica intrecciata su struttura in alluminio. L'antica cultura artigianale degli intrecciatori si fonde all'innovazione estetica e funzionale di un materiale a base polietilenica perfetto per l'esterno. Proposta in colore Black Core 6 mm.

The Wapiti outdoor collection is made in synthetic fiber woven on aluminum frame, furniture in which the weavers' ancient craft culture blends to aesthetic and functional innovation of extruded polyethylene wicker. The standard colour for the 6 mm Core synthetic fibre is Black.

WAPI4319

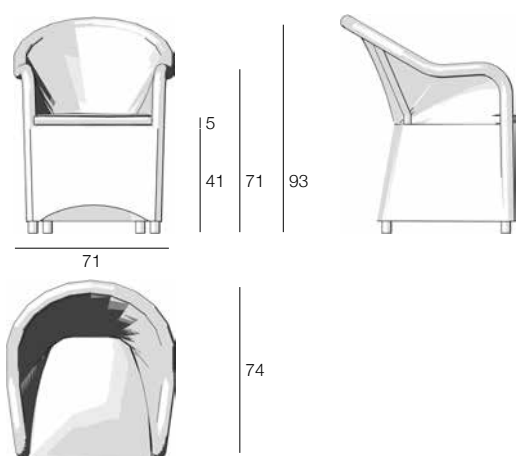

WAPI4428

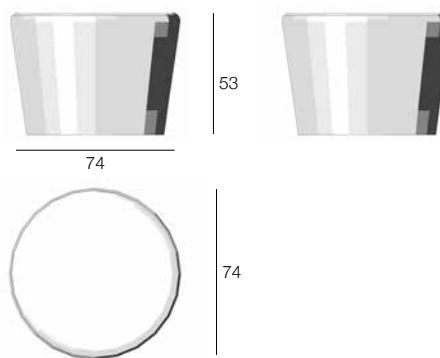

WAPI4319 + WAPI4319-CUS



WAPI4428



WAPI4319
WAPI4428



WHITE SAND

design by CRS SILAT

I mobili della linea White Sand sono trattati con uno speciale metodo di finitura, un'esclusiva de Il Giardino di Legno. Questo metodo consiste in otto fasi successive che evidenziano il carattere del legno di Teak usato per le strutture e le sedute di sedie e tavoli. Il divano può essere accompagnato da cuscini; la sedia ha seduta e schienale in tessuto tecnico traforato proposto in colore blu.

The furnishings of the White Sand line are treated with a special finishing method, exclusive to Il Giardino di Legno. This method consists of eight subsequent phases aimed to enhance the character of the Teak used for the frames and seats of chairs and tables. The sofa can be fitted with cushions; the seat and backrest of the chair are made with blue technical fabric.

WWSA6201



WWSA6201 + WWSA6201-CUS + PILW



WWSA6401



WWSA6301 + K01



WWSA6402



WWSA6403



WWSA6201

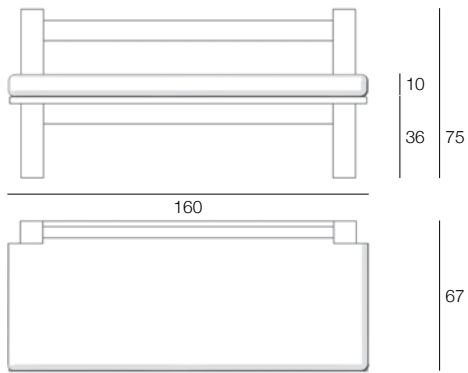

WWSA6301

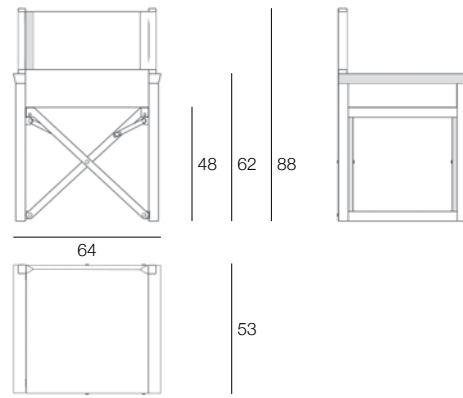

WWSA6401

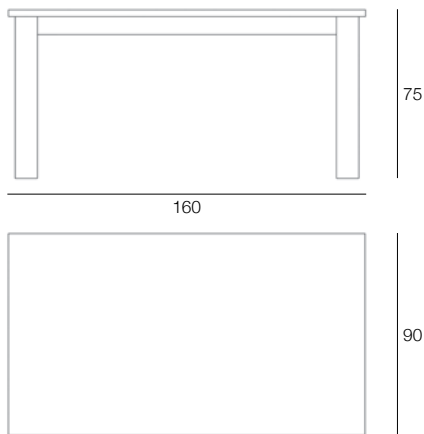

WWSA6402

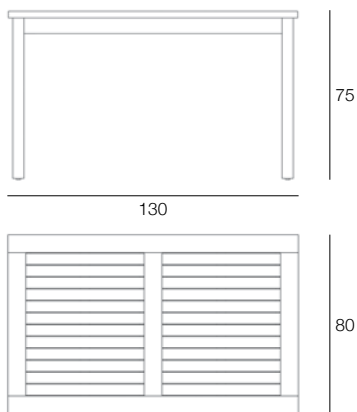

WWSA6403

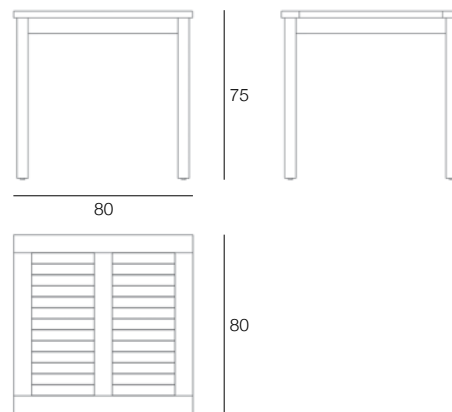

ZEFIRO

design by CRS SILAT

Gli arredi della linea Zefiro sono realizzati con una struttura in solido e leggero tubolare di alluminio, con un rivestimento in poliuretano a cella aperta e tessuto acrilico. I piedini, in alluminio, sono dotati di vite regolabile. Il tavolo basso è in legno di Teak a finitura decapata "White Wash", con ripiano superiore in vetro satinato.

The furnishings of the Zefiro line feature a light but solid tubular aluminium frame lined with open-cell polyurethane and acrylic fabric. The feet are made of aluminium and are equipped with an adjustable screw so that each side can be adapted to guarantee alignment on uneven or irregular surfaces. The low table is made of Teak wood with "White Wash" pickled effect finish with frosted glass top.

ZEFI8203



ZEFI8204



ZEFI8205



ZEFI0474



2 X ZEFI8203
1 X ZEFI8204



1 X ZEFI8203
1 X ZEFI8204
1 X ZEFI8205



ZEFI8203

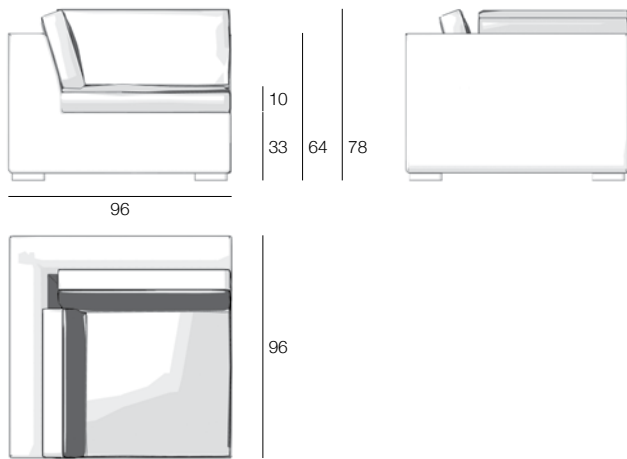

ZEFI8204

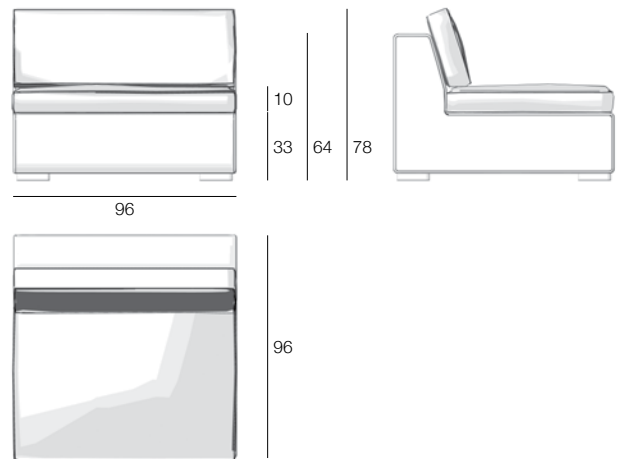

ZEFI8205

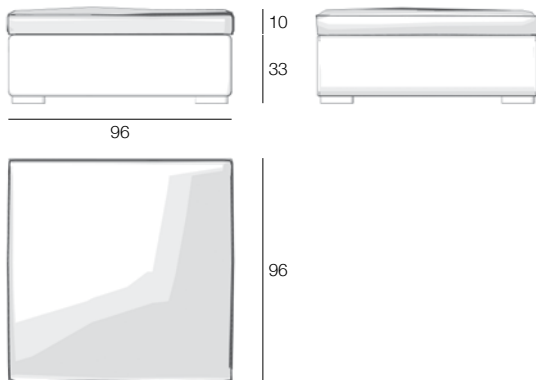

ZEFI0474

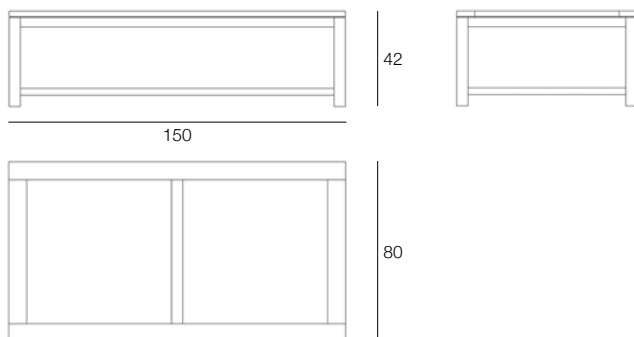

ACCESSORI

ACCC0826

Accessori e complementi in Teak o in fibra sintetica intrecciata su struttura in alluminio. Dettagli in acciaio e piedini antigraffio su molti degli elementi proposti. Interni in zinco disponibili su richiesta per i portavasi. La finitura standard degli accessori è levigatura fine per il Teak e White Wash foc 6mm per la fibra sintetica intrecciata.



ACCC5823

Accessories and complements in Teak wood or synthetic fibre woven on aluminium frame. Many of the elements proposed feature steel accents and anti-scratch feet. Zinc interior available on request for plant pot holders. The standard finishing is Fine Sanded Teak wood and White Wash foc synthetic fibre.



ACCC4814



ACCC0826

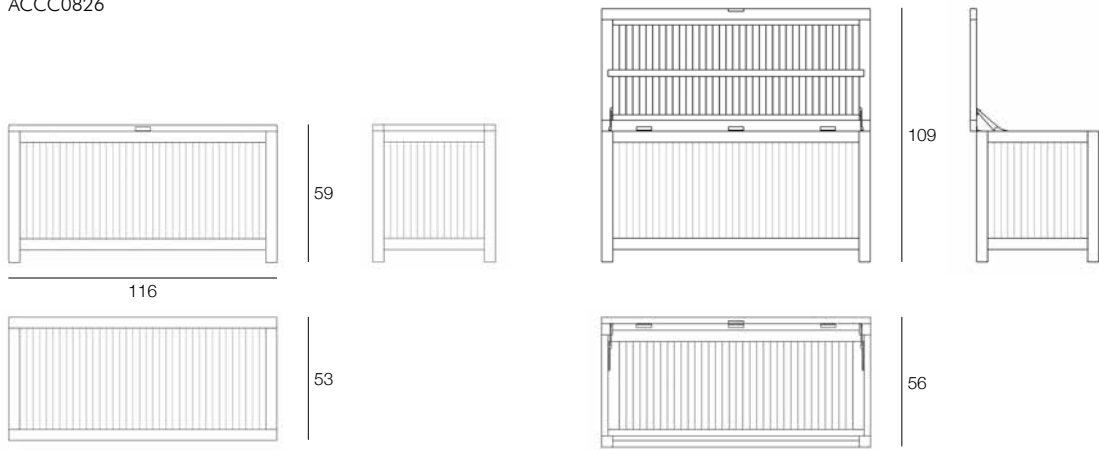

ACCC5823

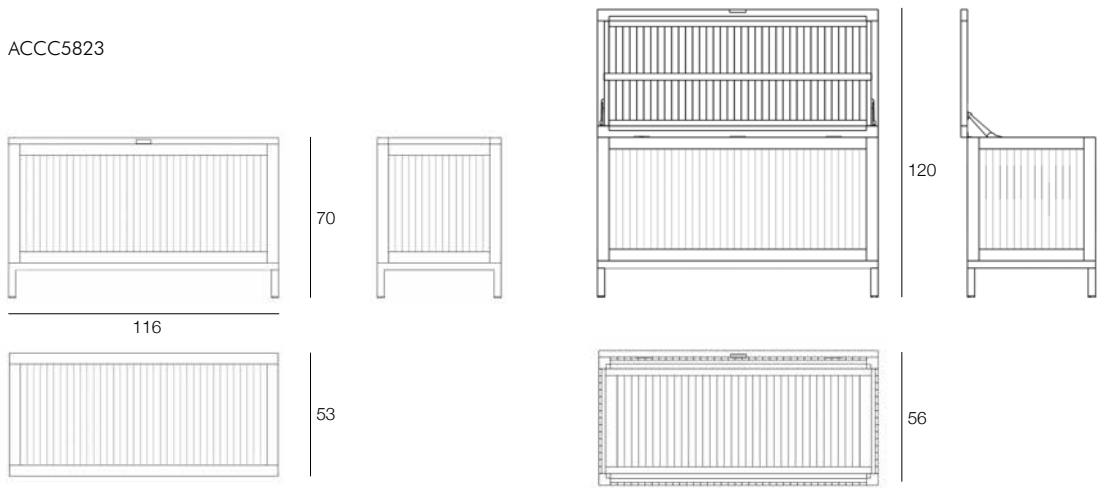

ACCC4814

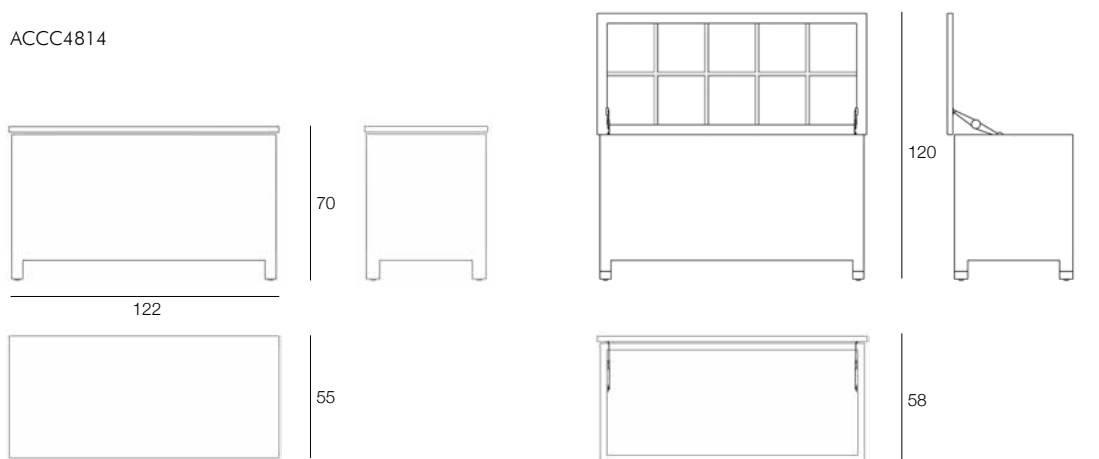

ACCC0841



ACCC0841



ACCC0842



ACCC0842



ACCC4816



ACCC4816



ACCC0841

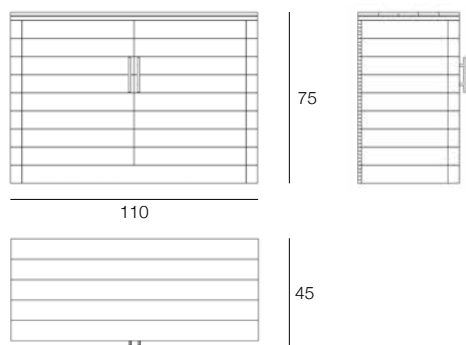

ACCC0842

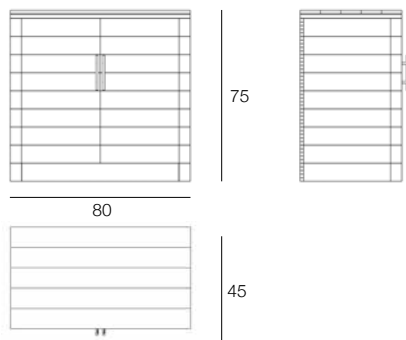

ACCC4816

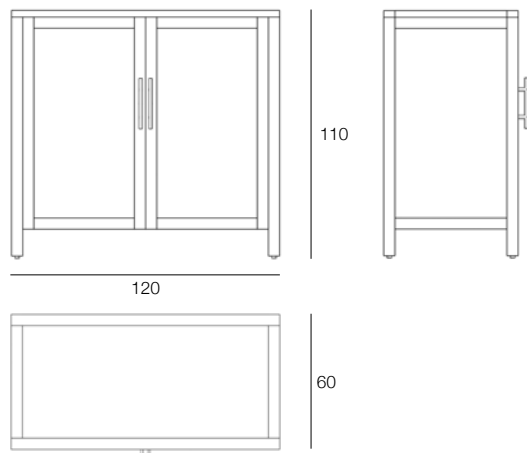

ACCC0843 + ACCC0843-CUS



ACCC0843 + ACCC0843-CUS



ACCC0846

ACCC0846



ACCC0847



ACCC0847



ACCC0843

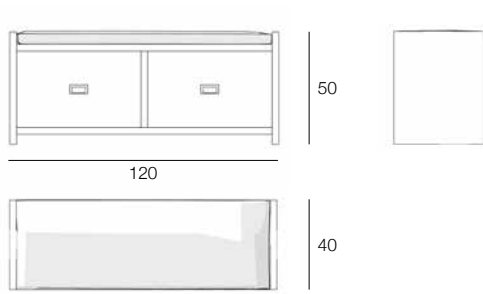

ACCC0846

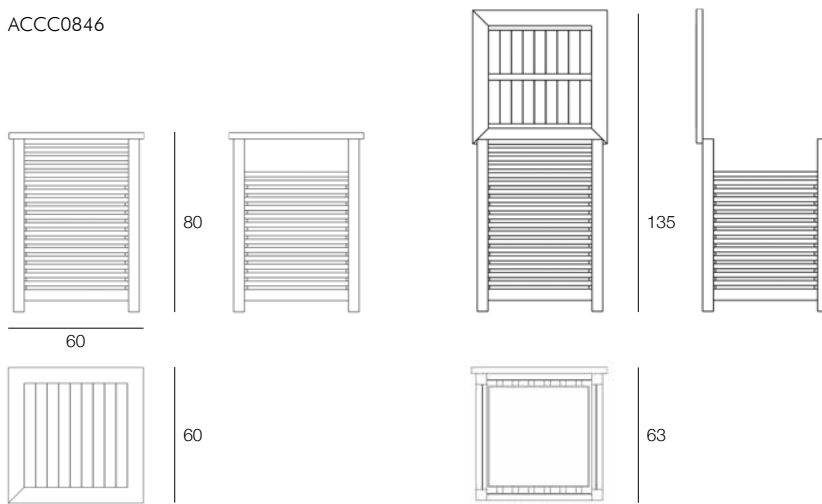

ACCC0847

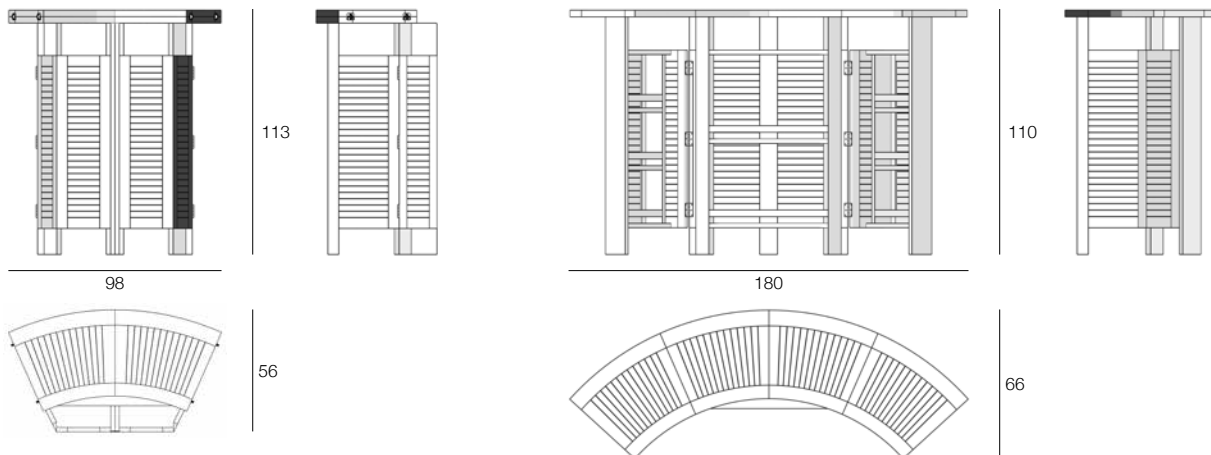

ACCP0821



ACCP5806



INDEX : ACCP

- ACCP0803 → p.200
- ACCP0821 → p.196
- ACCP0822 → p.196
- ACCP0823 → p.198
- ACCP0824 → p.198
- ACCP0825 → p.198
- ACCP0827 → p.202
- ACCP0828 → p.200
- ACCP0829 → p.200
- ACCP0830 → p.200
- ACCP0857 → p.200
- ACCP0858 → p.200
- ACCP4806 → p.196
- ACCP4807 → p.196
- ACCP4808 → p.202
- ACCP4809 → p.198
- ACCP4810 → p.198
- ACCP4811 → p.198
- ACCP5806 → p.196
- ACCP5807 → p.196
- ACCP5808 → p.196
- ACCP5809 → p.196
- ACCP5810 → p.202
- ACCP5811 → p.202
- ACCP5812 → p.202
- ACCP5813 → p.202
- ACCP5814 → p.202
- ACCP5815 → p.202
- ACCP5816 → p.202
- ACCP5817 → p.198
- ACCP5818 → p.198
- ACCP5819 → p.198
- ACCP5820 → p.198
- ACCP5821 → p.198
- ACCP5822 → p.198
- ACCP5827 → p.202

ACCP4806



ACCP5808



ACCP0822



ACCP5807



ACCP4807



ACCP5809



ACCP0821

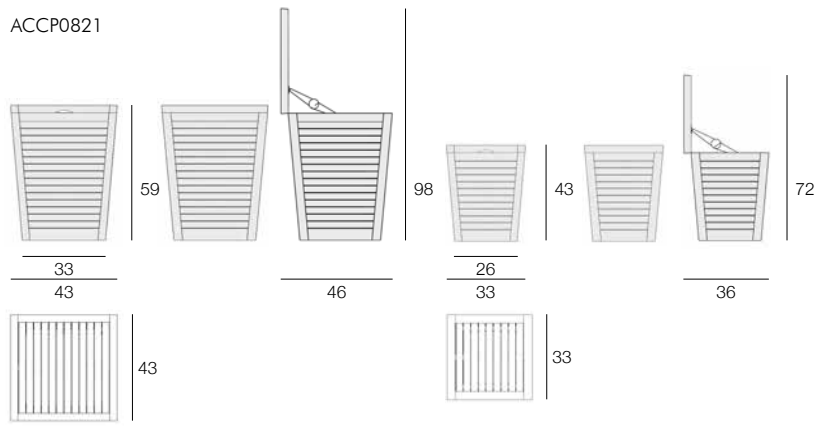

ACCP5806

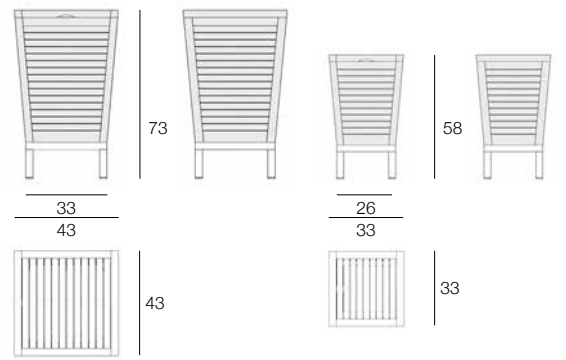

ACCP4806

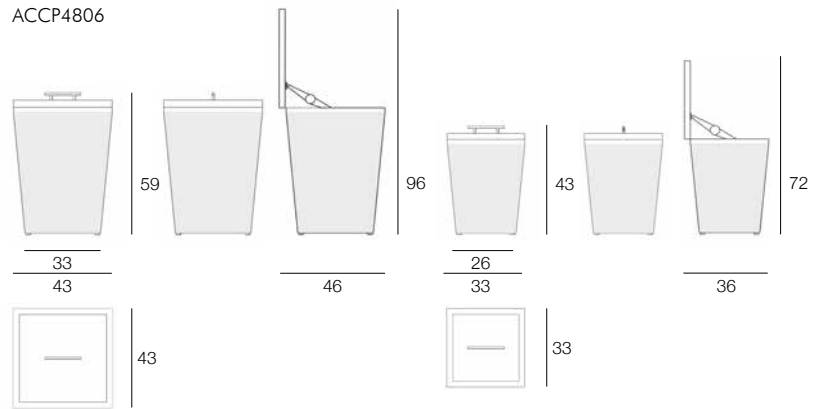

ACCP5808

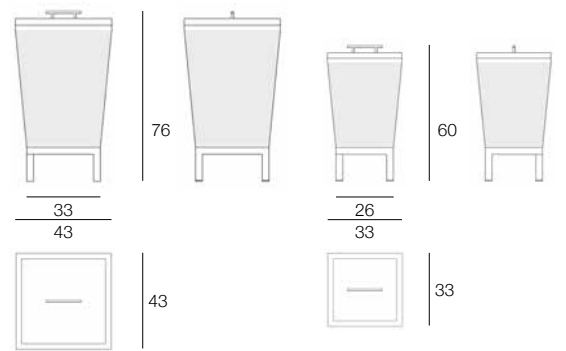

ACCP0822

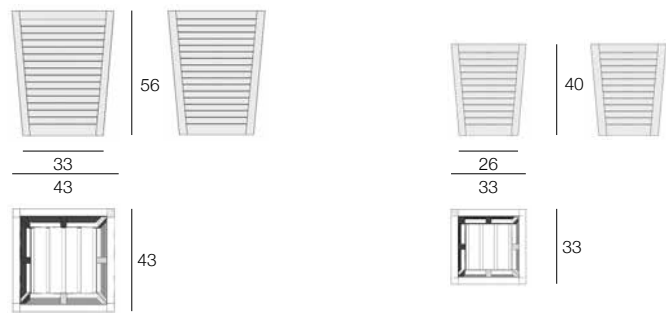

ACCP5807

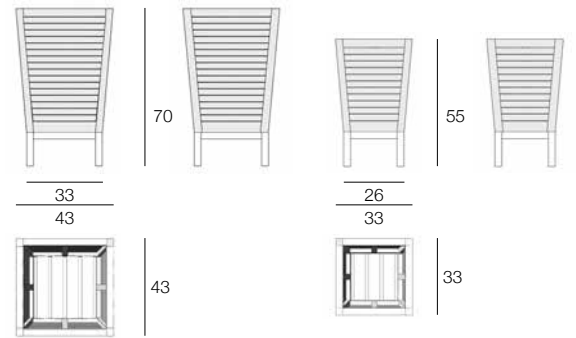

ACCP4807

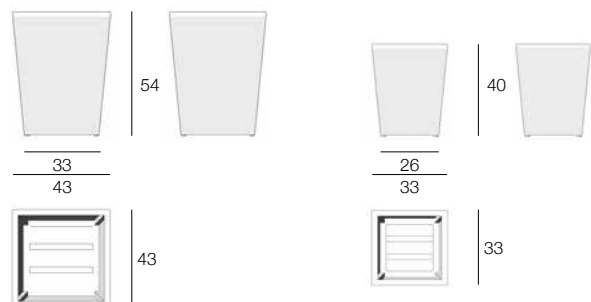

ACCP5809

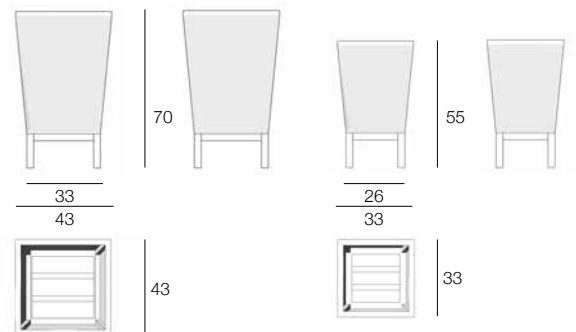

ACCP0823



ACCP0824



ACCP0825



ACCP4809



ACCP4810



ACCP4811



ACCP5817



ACCP5818



ACCP5819



ACCP5820



ACCP5821



ACCP5822



ACCP0823

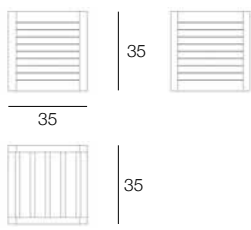

ACCP0824

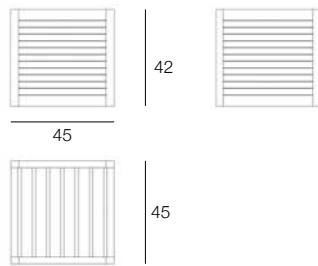

ACCP0825

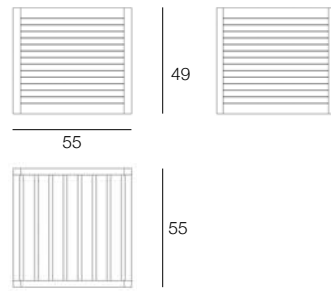

ACCP4809

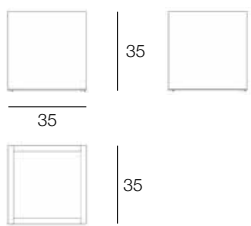

ACCP4810

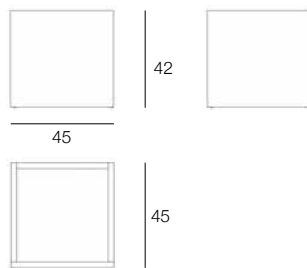

ACCP4811

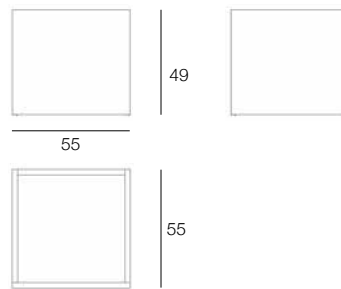

ACCP5817

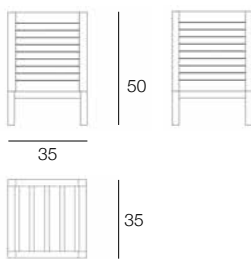

ACCP5818

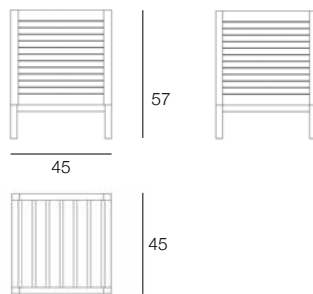

ACCP5819

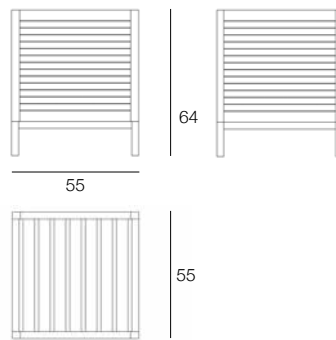

ACCP5820

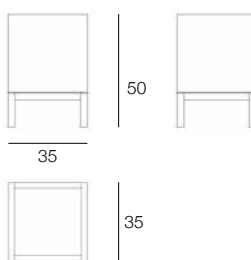

ACCP5821

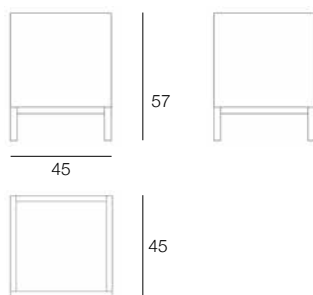

ACCP5822

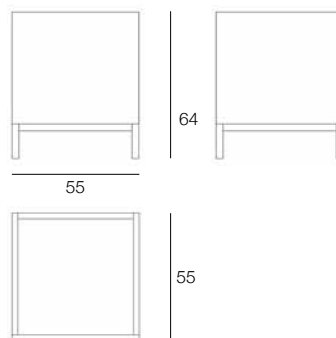

ACCP0803



ACCP0857



ACCP0858



ACCP0828



ACCP0829



ACCP0830



ACCP0803

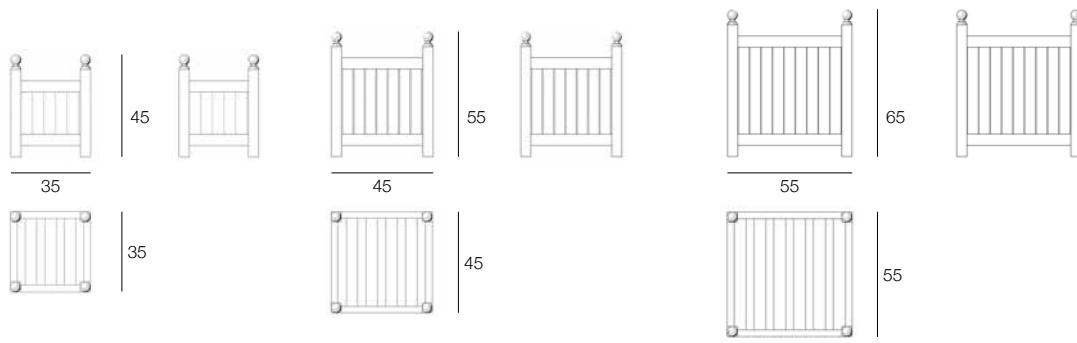

ACCP0857

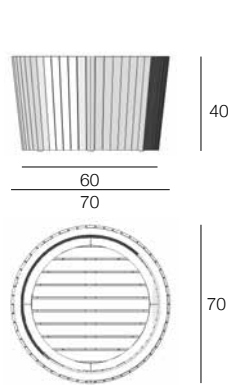

ACCP0858

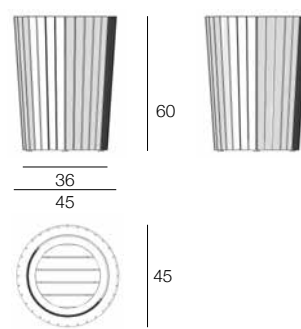

ACCP0828

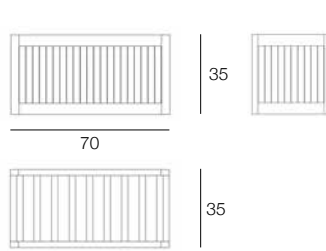

ACCP0829

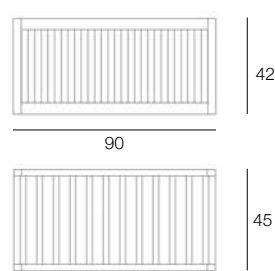

ACCP0830

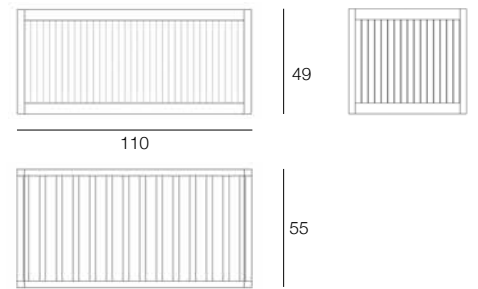

ACCP0827



ACCP4808



ACCP5827



ACCP5810



ACCP5811



ACCP5812



ACCP5813



ACCP5814



ACCP5815



ACCP5816



ACCP0827

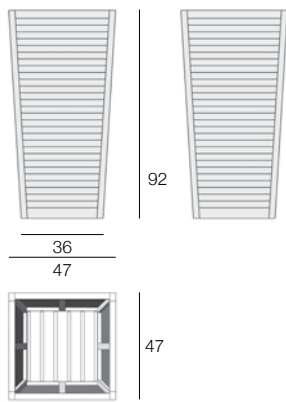

ACCP4808

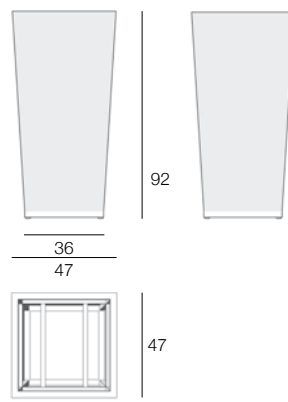

ACCP5827

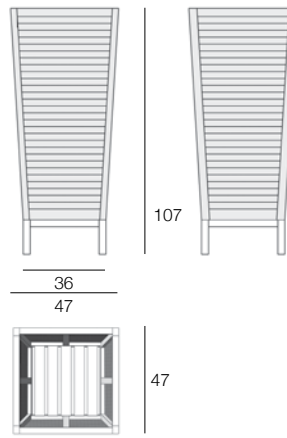

ACCP5810

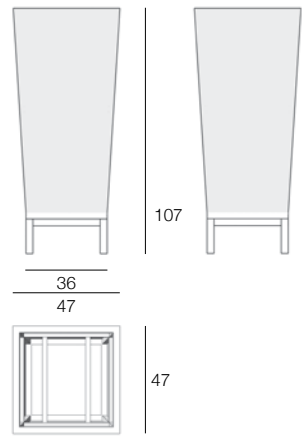

ACCP5811

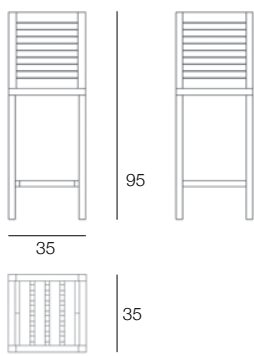

ACCP5812

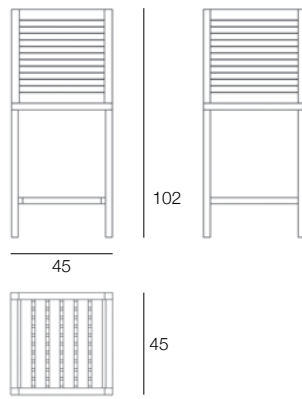

ACCP5813

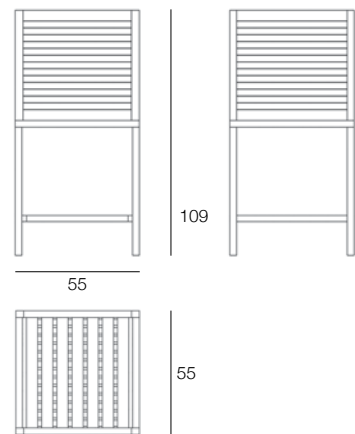

ACCP5814

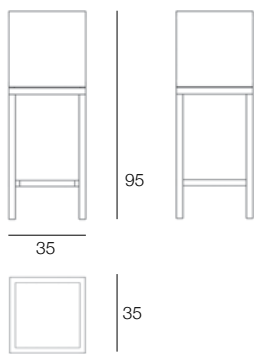

ACCP5815

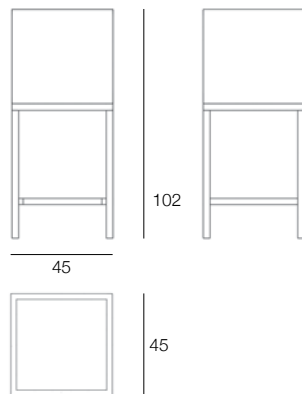

ACCP5816

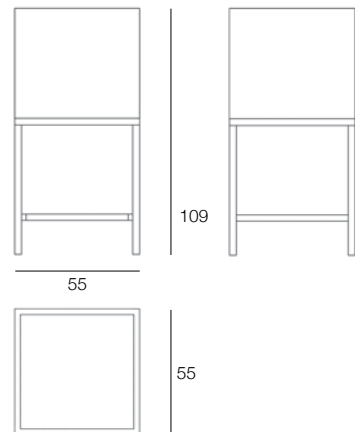

ACCS0804



ACCS0831



ACCS0832



ACCS0833



ACCS0813



ACCS0845



ACCS5804



ACCS0804

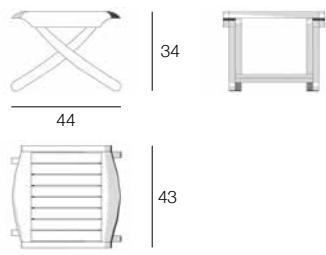

ACCS0831

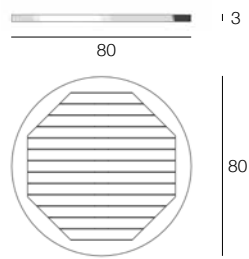

ACCS0832

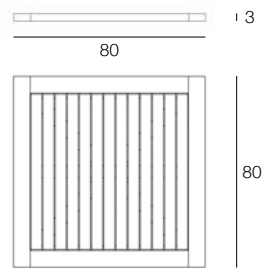

ACCS0833

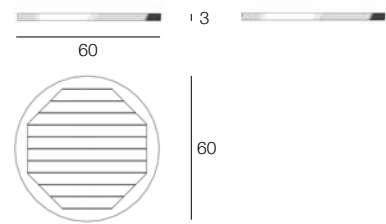

ACCS0813

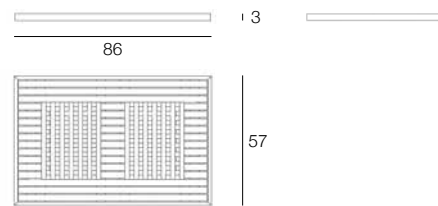

ACCS0845

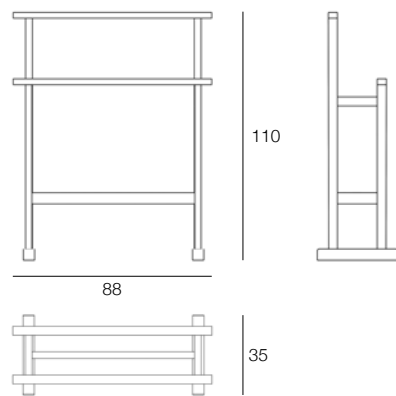

ACCS5804

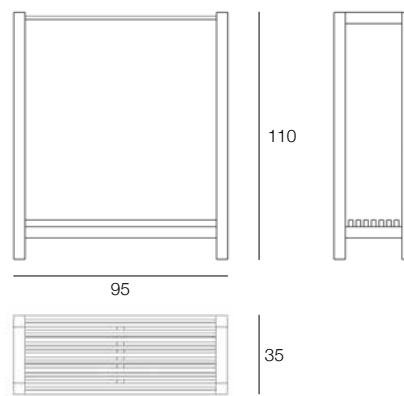

ACCS0811



ACCS0812



ACCS0811

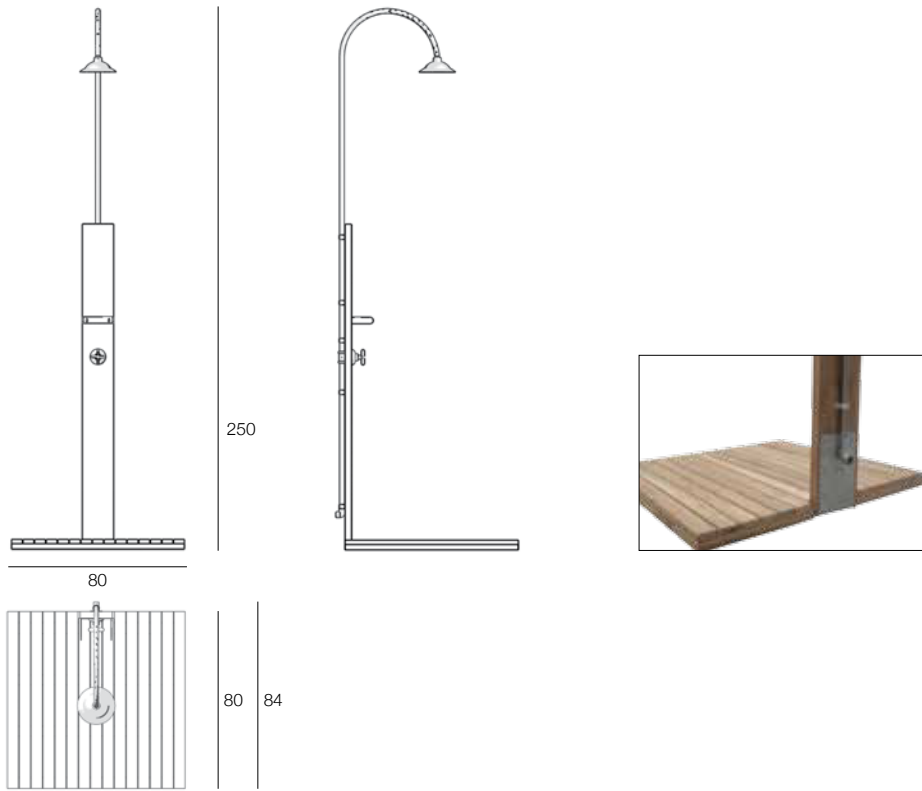

ACCS0812

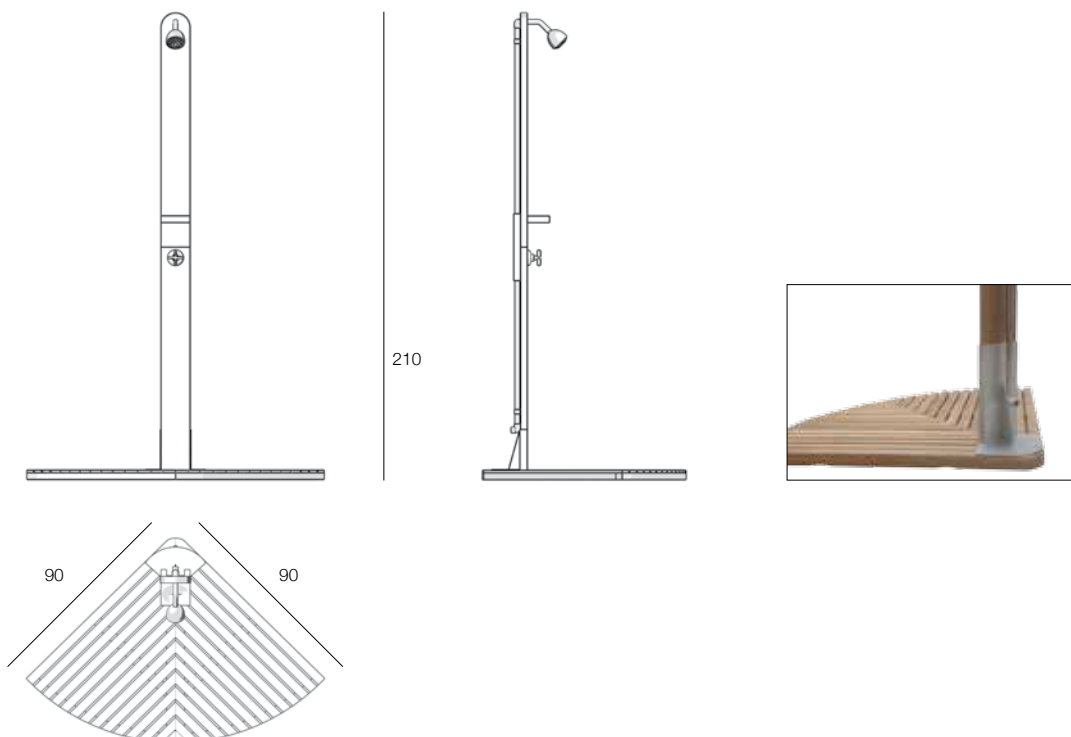

ACCT0801



ACCT0801



ACCT5801



ACCT5802



ACCT0810



ACCT0810



ACCU4812 + ACCU4812-CUS



ACCU4813 + ACCU4813-CUS



ACCT0801

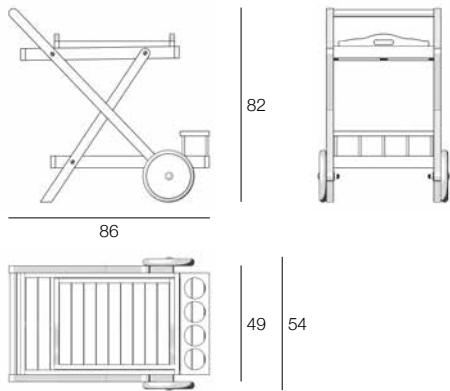

ACCT5801

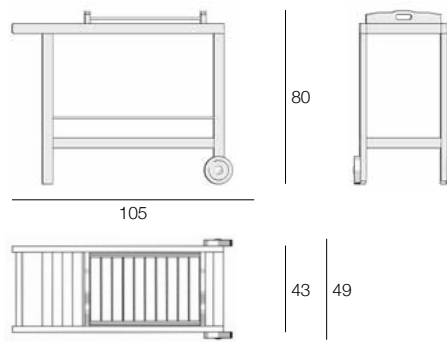

ACCT0810

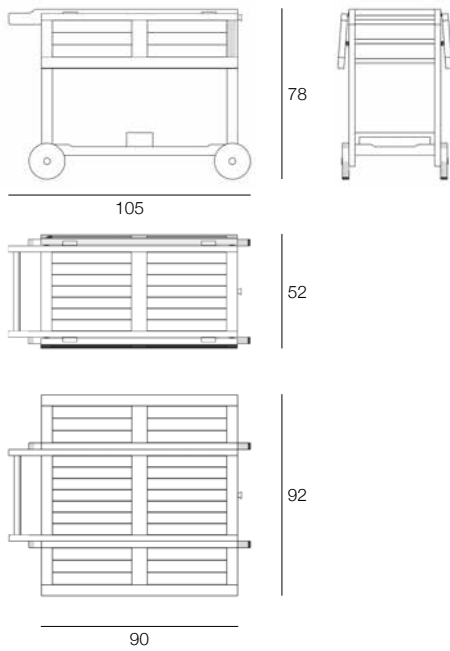

ACCT5802

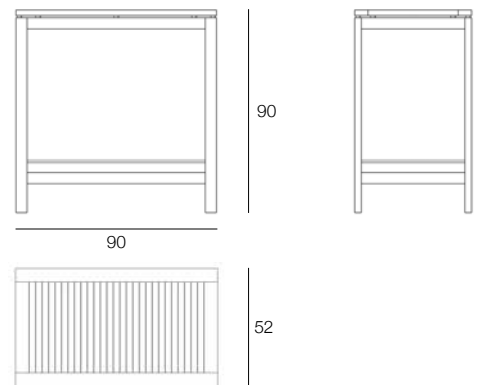

ACCU4812

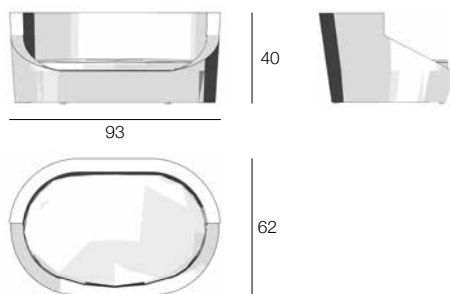

ACCU4813

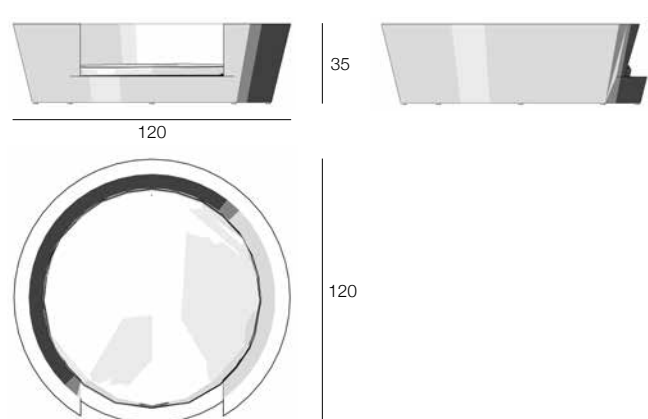

ACCV0805



ACCV0806



ACCV4802



ACCV4804



ACCV4803



ACCV0820



ACCV4805



ACCV4805



ZPSS0030



ZPIS0322



ZPWS0414



ZPCH0145



ZPCR0035



ZPCH0055



ZPMR0050



ACCV0805

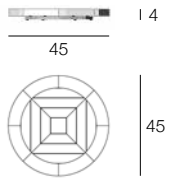

ACCV0806

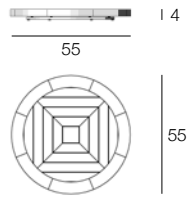

ACCV4802

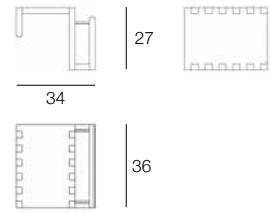

ACCV4804

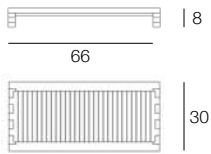

ACCV4803

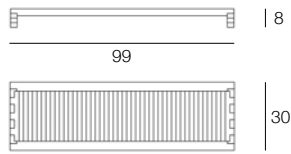

ACCV0820

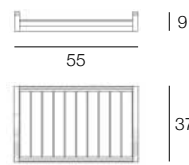

ACCV4805

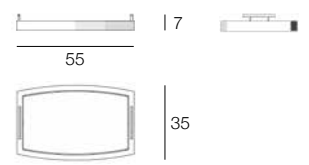

ZPSS0030

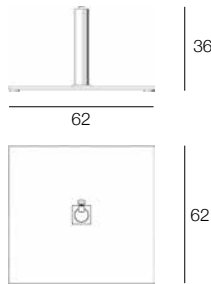

ZPIS0322

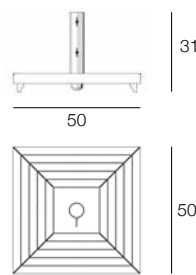

ZPWS0414

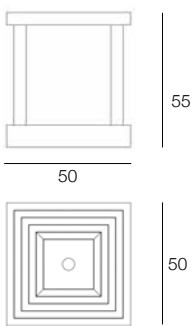

ZPCH0145

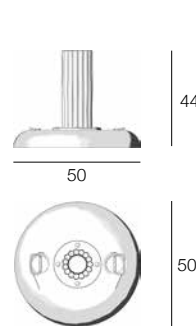

ZPCR0035

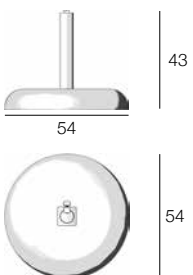

ZPCH0055





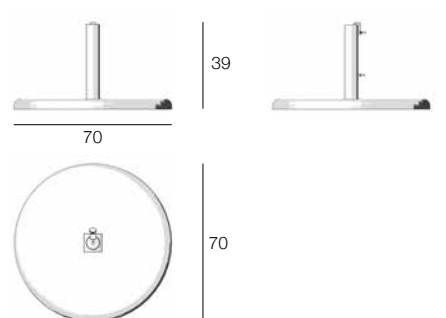







ZPMR0050



OMBRELLONI

Struttura a palo centrale o laterale, disponibile in legno o in metallo. Dimensioni personalizzabili. Basi in metallo, cemento o marmo. Possibilità di fissaggio diretto a terra. Su richiesta disponibili accessori per il riscaldamento, il raffrescamento, l'illuminazione, la cablatura o le canaline. Copertura in tessuto acrilico o in tessuto tecnico microforato oppure in fibra ETFE impermeabile. L'ombrellone Exotic differisce dagli altri perché la copertura è in paglia naturale 'Canna del Capo'.

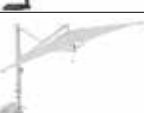
Structure with central or side pole, available in wood or metal. Customisable dimensions. Metal, cement or marble bases. It can be fixed directly in the ground. Heating, cooling, lighting accessories, wiring or cable ducts available on request. Acrylic fabric or microperforated technical fabric or waterproof ETFE fibre cover. The exotic parasol differs from the others as the cover is made of Cape Reed natural straw.

| | | → cm | ∅ 200 | ∅ 250 | ∅ 300 | ∅ 350 | ∅ 400 | ∅ 500 | 200 x 200 | 300 x 300 | 350 x 350 | 300 x 400 | 400 x 400 | 500 x 500 | 600 x 600 | 700 x 700 |
|---|--------------------------------------|-----------|-----------|-----------|-------|-----------|-------|-------|-----------------|-----------------|-----------------|-----------------|-----------------|-----------------|-----------------|-----------------|
|  | Central Post Wood | ✓ | ZOCW 2500 | ZOCW 3000 | ✓ | ✓ | | | ZOCW 2020 | ZOCW 3030 | ✓ | ✓ | ✓ | | | |
|  | Central Post Tilt Wood | ✓ | ZOLW 2500 | ✓ | | | | | ✓ | ✓ | | | | | | |
|  | Central Post Aluminium | ✓ | ✓ | ZOCA 3000 | ✓ | | | | ✓ | ZOCA 3030 | ✓ | ✓ | | | | |
|  | Central Post Cape Reed | ZOCR 2000 | | | | | | | | | | | | | | |
|  | Central Post Telescopic Wood | | | | ✓ | ZOTW 4000 | ✓ | | | | ✓ | ✓ | ZOTW 4040 | ✓ | | |
|  | Central Post Telescopic Aluminium | | | | ✓ | ZOTA 4000 | ✓ | | | | ✓ | ✓ | ZOTA 4040 | ✓ | ZOTA 6060 | |
|  | Side Post Wood | | | | ✓ | | | | | ZOSW 3030 | ✓ | ZOSW 3040 | | | | |
|  | Side Post Aluminium | | | | ✓ | ✓ | | | | ✓ | ✓ | ✓ | ✓ | | | |
|  | Side Post Retractable Aluminium | | | | | | | | | ZORA 3030 | ZORA 3535 | ✓ | ✓ | | | |
|  | Side Post Dual/Four Canopy Wood | | | | | | | | | | | | | | ✓ | ✓ |
|  | Side Post Dual/Four Canopy Aluminium | | | | | | | | | | | | | | ✓ | ✓ |

✓ disponibile su richiesta / available on request

ZOLW2500

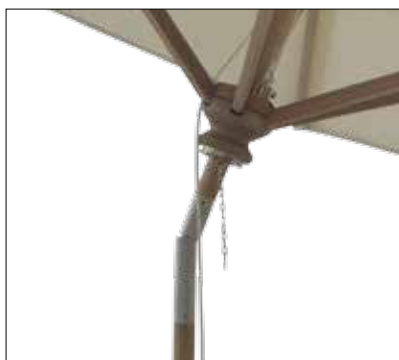
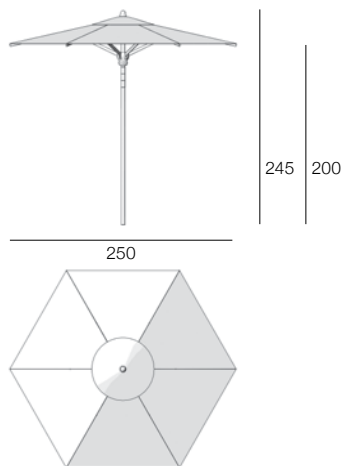

ZOCW2020

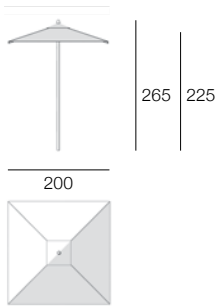

ZOCW3030

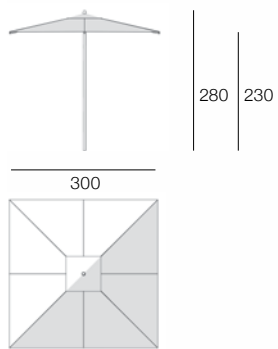

ZOCW3030 + ZPSS0030 + ZRWS0100

ZOCW2500

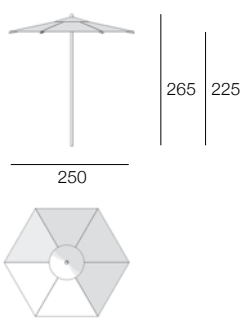

ZOCW3000

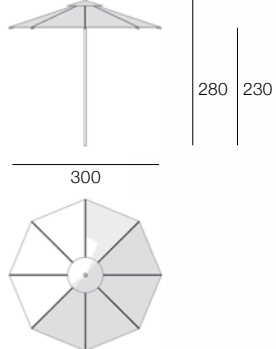

ZOCW2500 + ZPSS0030



ZORA3535 + 2 x ZQCQ0080



ZORA3535 + 2 x ZQCQ0080

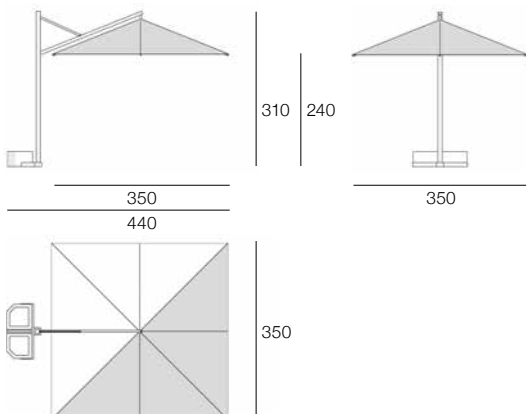

ZORA3030+ 2 x ZQCQ0080

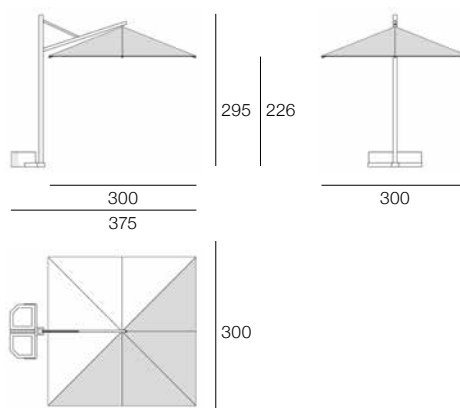



ZOCR2000 + ZPCH0145

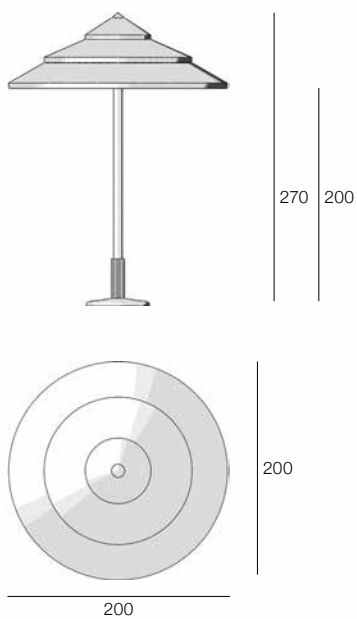

ZOCR2000 + ZPCH0145



ZOCD1800

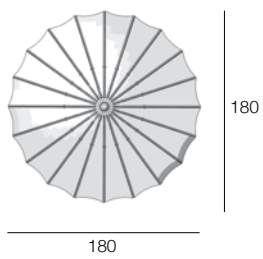
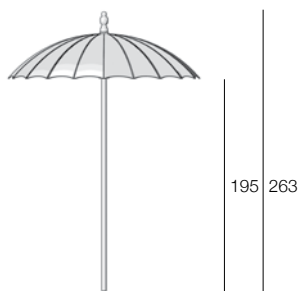

ZOCD1800

CAMILLA LAPUCCI LAPO BIANCHI LUCI



Camilla Lapucci e Lapo Bianchi Luci, l'uno architetto e l'altro designer, lavorano insieme dal 2002 esplorando differenti territori che spaziano dall'architettura all'interior design, dalla direzione artistica al graphic design.

Le differenti singole precedenti esperienze in prestigiosi studi di Architettura di Firenze sono confluite in un percorso comune che ha poi permesso di iniziare un'intensa collaborazione con il mondo dell'interior design e del wellness, occupandosi di progetti di architettura e di interni a livello nazionale ed internazionale, coprendo diversi settori.

Ogni progetto è concepito attraverso un'accurata scelta di materiali e di superfici, di volumi, di pieni e di vuoti in reciproca relazione.

Nel settore delle SPA hanno ricevuto diversi riconoscimenti e premi tra cui il premio del Gran Prix Casalgrande e la menzione speciale al Wellness Design Awards.

Camilla Lapucci and Lapo Bianchi Luci, the first architect and the other designer, have been working together since 2002 to explore different areas, ranging from architecture to interior design, from art direction to graphic design.

The different individual previous experience in prestigious Architecture firms in Florence have merged into a common path that has allowed them to begin an intense collaboration with the world of interior design and wellness dealing with architectural and interior design projects at national and international levels.

Each project is conceived through a careful choice of materials and surfaces, volumes, solids and voids in a mutual relationship.

Concerning the SPA projects, they have received several awards and prizes, including the 1st prize in the Grand Prix Casalgrande in 2007 and a special mention at the Wellness Design Awards 2008.

SAM SANNIA



Sam Sannia, designer di nazionalità italo-inglese, già dalle sue prime apparizioni nel circuito del design viene notato dalla stampa e pubblicato su numerose riviste e libri di settore. I suoi progetti sono stati esposti in diverse mostre come ICFF (New York), New Designers (Londra), e il Salone Satellite di Milano. Oggi Sam Sannia collabora con aziende leader nel settore del mobile.

Sam Sannia, Anglo-Italian designer, has been noticed by the press since its first appearances on the public stage. He has been published on several magazines and books. His projects have been exposed in many different exhibitions: at the ICFF (New York), the New Designers (London), at the Salone Satellite (Milan). Today, Sam Sannia works with several furniture leader companies.

FEDERICA FERRARA



Maestro d'Arte per il Restauro delle Opere Lignee presso l'Istituto d'Arte Amleto Bertoni di Saluzzo, inizia a lavorare presso alcuni studi di architettura dove matura significative esperienze nel campo del design e della progettazione di interni. Si laurea alla Facoltà di Architettura del Politecnico di Torino e collabora con importanti architetti approfondendo gli studi di Interior ed Exterior Design e dedicandosi ad esperienze progettuali in differenti contesti. Dedita con passione alla sperimentazione con le materie lignee e al loro abbinamento a materiali tecnologici, interpreta la casa come un involucro permeabile dove interno ed esterno si fondono utilizzando lo stesso linguaggio compositivo e formale.

Federica Ferrara has qualified as "Maestro d'Arte" in restoration of wood work at the Amleto Bertoni Art Institute in Saluzzo, in the north of Italy. She began working in various architectural firms where she developed significant experience in interior design. She graduated from the Faculty of Architecture at the Politecnico of Turin and works alongside important architects, honing her Interior and Exterior Design skills and working on several types of projects set in different contexts. Her passion for experimenting with wood and combining it with technological material, has led her to interpret the home as a permeable shell where indoor and outdoor spaces merge together using the same artistic and formal language.

A3DIMENSIONI



Lo studio A3DIMENSIONI si dedica alla pianificazione architettonica e all'interior design di complessi residenziali, spazi commerciali, ristoranti, così come di progettazione di spazi espositivi e di vendita in diversi settori. Fondato nel 2008 da Michele Giannetti, Elisabetta Baldi e Luca Donisotti, il lavoro dello studio è caratterizzato dalla capacità di offrire soluzioni di eleganza discreta sulla base di geometrie semplici, dalla sperimentazione con i materiali, dal fondere industria e artigianato con un occhio sempre attento agli aspetti funzionali, tecnici e produttivi. Un gruppo fatto di conoscenze ed esperienze professionali differenti, da cui scaturiscono soluzioni originali segnate dal coinvolgimento dell'utente finale.

A3DIMENSIONI studio is dedicated both to the architectural planning and interior design of residential complexes, business spaces, restaurants and to the planning of exhibition areas and sales spaces in various business sectors. Founded in 2008 by Michele Giannetti, Elisabetta Baldi and Luca Donisotti, this studio offers solutions which convey minimal elegance based on simple geometrical patterns, experimenting with materials, combining industry and handcrafts, always paying special attention to functionality, technicality and production. A team who joins different professional backgrounds and know-how to create original solutions taking into account the customer's requirements at all times.

MAINTENANCE

Il legno è un materiale 'vivo' che, in relazione al luogo in cui viene posizionato, può richiedere una particolare manutenzione. Con l'applicazione dell'olio e della cera, il Teak risulterà perfettamente protetto e ravvivato nel colore. L'olio per Teak può essere usato su legno grezzo come unico e completo agente protettivo, oppure su legno già trattato, purchè preventivamente pulito, come prodotto per la manutenzione. La cera fornisce uno strato protettivo ulteriore, pressoché invisibile, che riduce la penetrazione di macchie di oli e liquidi sulla superficie del legno. Si tratta di una cera in pasta di colorazione neutra, costituita da una miscela di elementi naturali selezionati tra cui cera d'api, cera carnauba ed essenza di trementina. I kit di manutenzione de Il Giardino di Legno sono ideali per lucidare e proteggere i mobili e gli oggetti in legno di Teak.

Wood is a "living" material which, depending on where it is placed, can require a particular maintenance. The Teak wood will result perfectly protected and brightened up the colour applying oil and wax. The oil for teakwood can be used on raw wood as single and complete protective agent or on already treated wood, provided that it has been cleaned before, as maintenance product. The wax provides a further protective layer, almost invisible, avoiding the food, oil and liquid stains to seep through the wood surface. It consists of a colourless wax paste, made of a mix of selected natural elements among which beeswax, carnauba wax and turpentine gum. The maintenance kits by Il Giardino di Legno are suitable to polish and protect teakwood furniture and objects.

MAIN2001



MAIN2002



MAIN2003



MAIN2004



MAIN2005



FINITURE

Tutti i manufatti lignei vengono prodotti con legno certificato e sottoposto a rigorosi controlli sia interni che da parte delle autorità competenti, lungo tutto il processo produttivo dalla piantagione alla consegna, secondo la rigida normativa europea FLEGT. Il legno utilizzato è legno di Teak della migliore qualità, disponibile nelle finiture 'Fine Sanded', ossia levigatura fine, 'Oil & Wax' eseguita con olio e cera, 'Java Brown' caratterizzata dalla pigmentazione scura color testa di moro, 'White Wash' e 'White Sand' dall'effetto decapato.

Per gli arredi della collezione Suar, viene usato legno massiccio tropicale di Suar per le sue caratteristiche crepe che, selezionate in fase di taglio e produzione, contraddistinguono la collezione. Proposto con levigatura grezza e finitura ad olio.

FINISHING

All the wooden manufactured products are made of certified wood accurately controlled both by our staff and by the competent authorities during the entire production, from plantation to delivery, in compliance with the FLEGT strict European regulations

Wooden collections are made with the best quality teak wood available in different finishes: 'Fine Sanded', 'Oil & Wax', 'Java Brown' characterized by dark brown pigmentation, 'White Wash' and 'White Sand' with pickled effect.

Suar furniture collection is entirely made of Suar tropical hardwood with raw sanding and oil finish. It is characterized by the cracks, suitably selected when cut and produced.

The stainless steel is a ferrous alloy that, thanks to nickel and chromium, is highly corrosion-



FINITURE

L'acciaio inossidabile è una lega ferrosa che, grazie al contenuto di nichel e cromo, è molto resistente alla corrosione. L'alluminio viene utilizzato per creare le strutture interne dei mobili in rattan: preventivamente trattato e verniciato per una migliore protezione agli agenti atmosferici, viene successivamente utilizzato come supporto per l'intreccio della fibra sintetica. Per l'uso esposto vengono utilizzati tubolari di alluminio vergine sottoposti a bagni di pulitura e verniciati a polvere.

Per gli intrecciati sono impiegate fibre sintetiche a base polietilenica che hanno qualità uniche di resistenza ai raggi UV, di riciclabilità e di resistenza agli sbalzi di temperatura. Inoltre non necessitano di manutenzione e sono insensibili a funghi e parassiti.

I piani in vetro hanno differenti bordature a seconda del modello e sono disponibili trasparenti, satinati, o fumè.

Il Batyline® è un tessuto che combina l'eleganza delle fibre naturali con la performance del tessile industriale. Gli imbottiti standard sono in poliuretano a densità differenziata, disponibili su richiesta imbottiture drenanti o a cella piena. I tessuti standard a rivestimento della cuscineria sono in acrilico colore ecrù.

Su richiesta possono essere usati tessuti colorati Sunbrella® o di altro tipo a scelta del Cliente.

GW - Vetro Latte / White Glass



GF-Vetro Satinato/Frosted Glass



FINISHING

The stainless steel is a ferrous alloy that, thanks to nickel and chromium, is highly corrosion-resistant.

Aluminium is used for the internal frames of the rattan furniture. It is previously treated and painted to better resist to weather conditions and then used to bear the synthetic fiber weave. Cleansed and powder coated tubular virgin aluminium structures are employed for an exposed use.

The polyethylenic based synthetic fibers used for the woven collections have unique UV ray resistant qualities, can be recycled and boast a good resistance to changes in temperature. Moreover they do not need any maintenance and are insensitive to fungus and parasites.

The glass tops have different edges according to the model and are available in transparent, satin or smoke-grey version.

The technical fabric Batyline® combines the elegance of the natural fibers to the performance of the industrial fabric.

The standard upholstered are made of low/high density polyurethane foam or flow-through foam on customer's request.

On customer request can be used coloured Sunbrella® fabrics or other brands.

CF - Bianco



TP - Grigio chiaro



CN - Ecrù/Natural



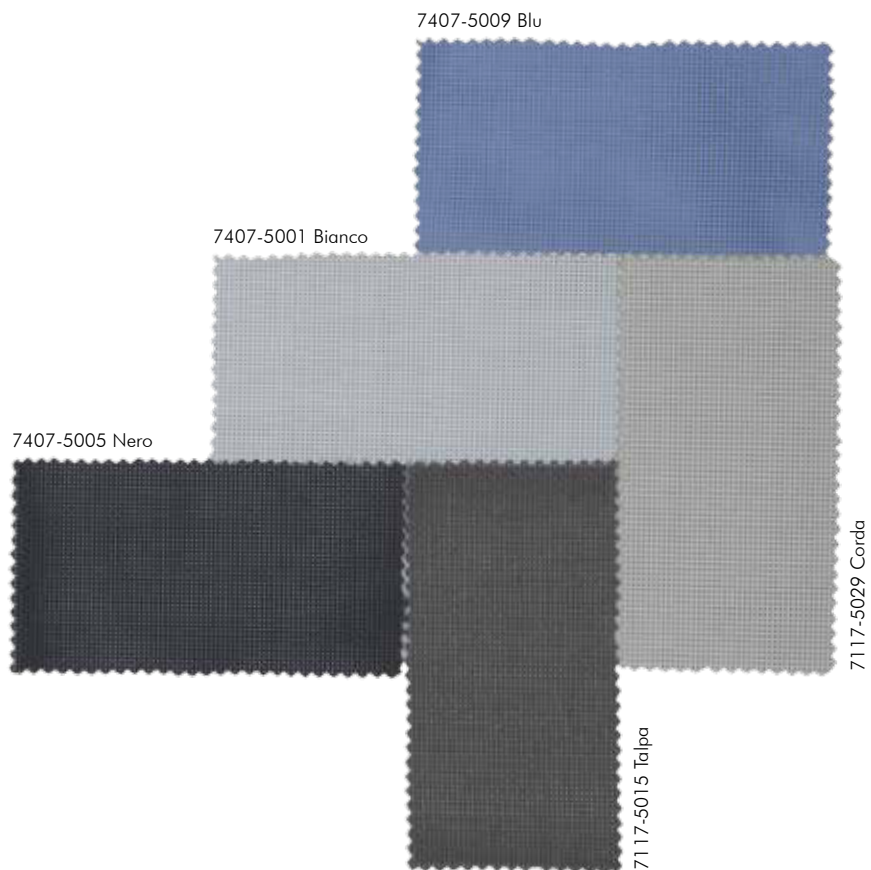
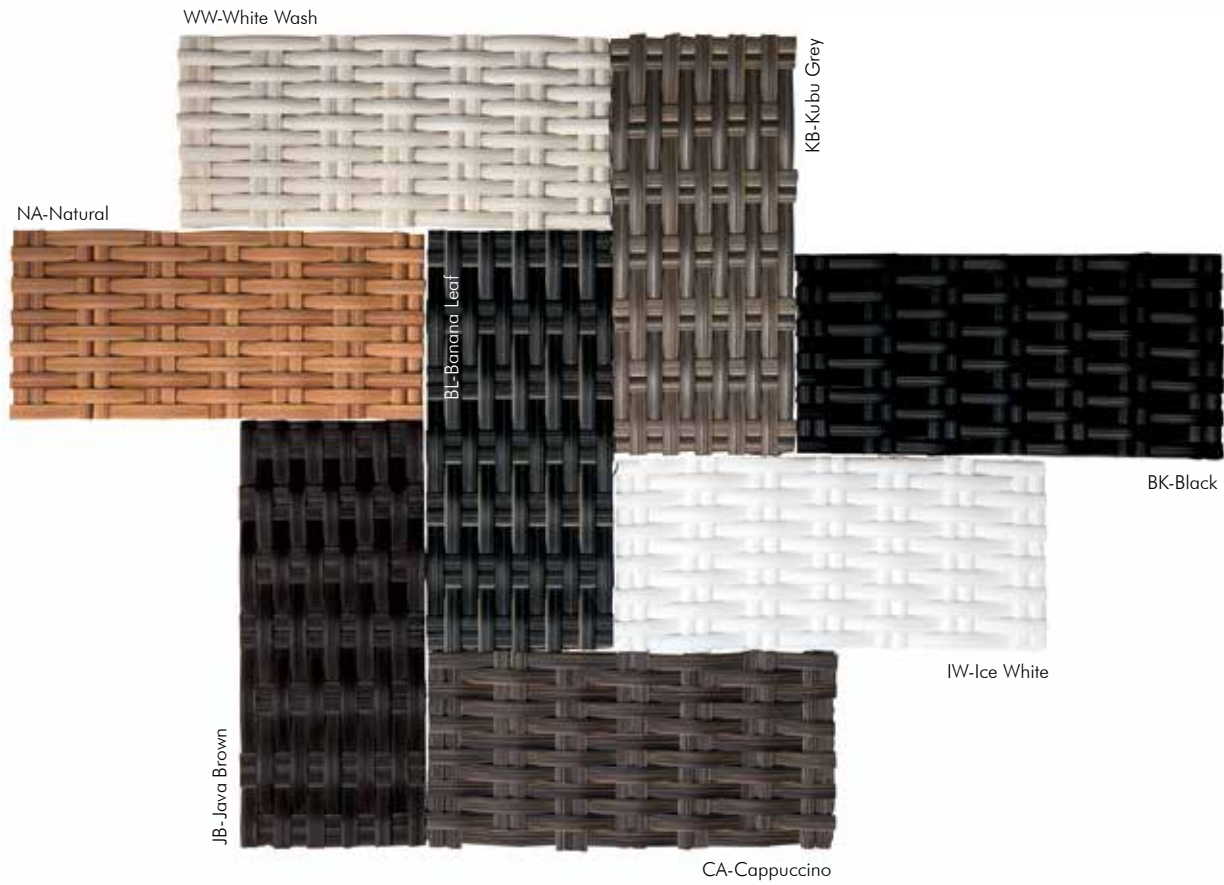



Il giardino di legno

Il Giardino di Legno
C.so Matteotti, 2 - Torino - Italia
Tel +39.011.45.46.863
Tel +39.011.19.50.24.29 Fax +39.011.19.50.24.30
info@ilgiardinodilegno.it www.ilgiardinodilegno.it



SILAT srl - All rights reserved

Il Giardino di Legno - Catalogo Tecnico [Secondo Natura]

Foto ambientate:

Styling: Cristina Nava e Andrea Fantechi

Photo: Stefania Giorgi, Lorenzo Pennati

L'azienda si riserva la facoltà di modificare, in qualunque momento e senza preavviso, le caratteristiche tecniche ed estetiche degli elementi illustrati nel presente catalogo.

The factory reserves the right to change, at any time and without prior warning, the technical or esthetic specifications of any product illustrated in this catalogue.

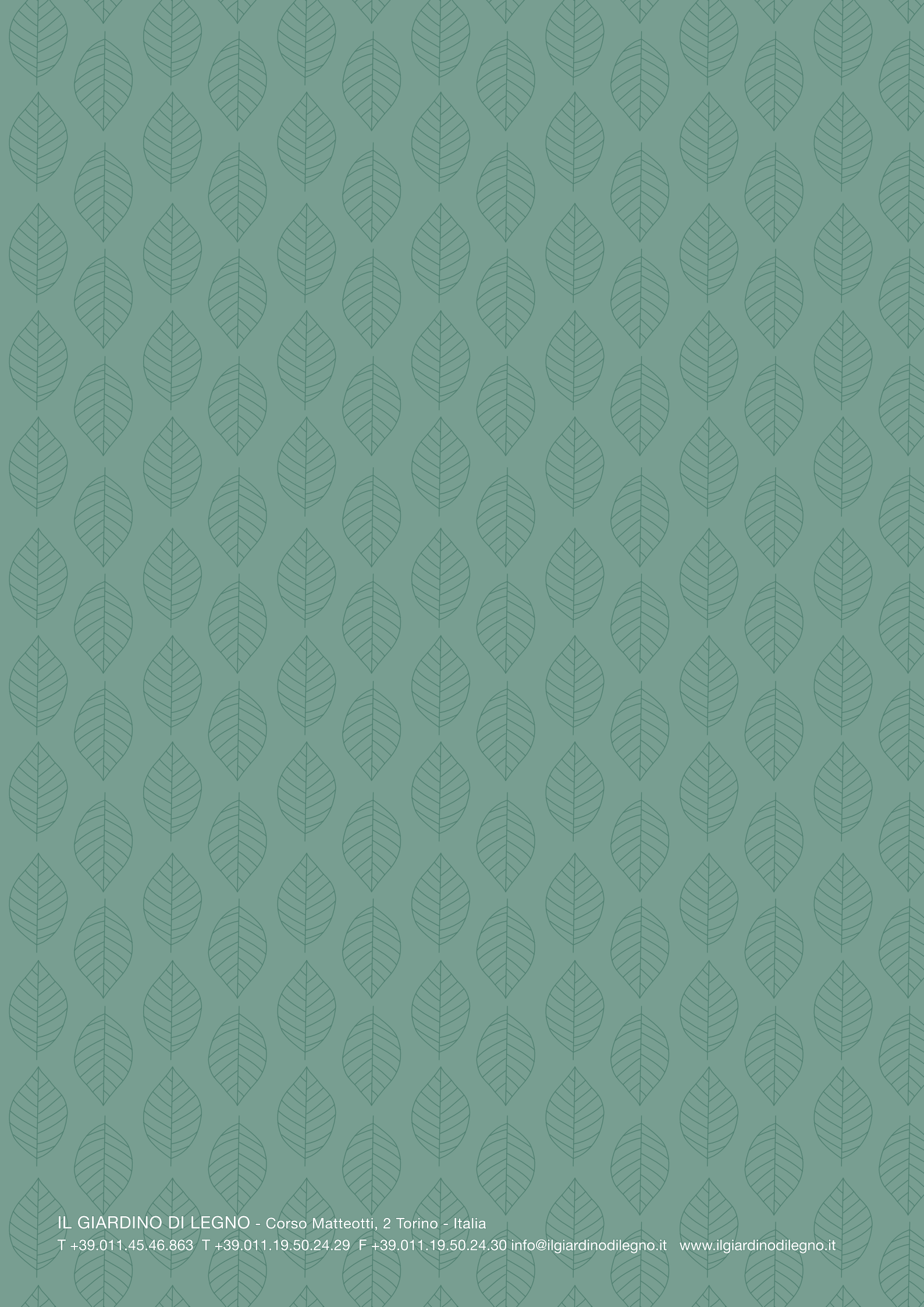

IL GIARDINO DI LEGNO - Corso Matteotti, 2 Torino - Italia

T +39.011.45.46.863 T +39.011.19.50.24.29 F +39.011.19.50.24.30 info@ilgiardinodilegno.it www.ilgiardinodilegno.it