



*Il giardino di legno*

VIAGGIO  
TROPICALE







*Il giardino di legno*

# Viaggio Tropicale

# IL GIARDINO DI LEGNO

Il Giardino di Legno progetta e produce con passione nel settore dell'arredamento, con particolare attenzione alla lavorazione del legno ed ai materiali per l'outdoor.

Il carisma silenzioso e le eclettiche competenze professionali ne caratterizzano non solo la produzione ma anche il supporto offerto al cliente e al progettista. La combinazione armonica di molteplici professionalità scaturisce in un gruppo di lavoro che affronta ogni progetto come una sfida, ogni richiesta del cliente come una mission, ogni ricerca di un nuovo materiale come uno stimolo per l'approfondimento delle proprie esperienze e conoscenze.

Una raccolta di oggetti d'arredo in cui differenti essenze, materiali e cromie si mescolano e si miscelano nel processo creativo per offrire nuove soluzioni ed essere fonte d'ispirazione per l'arredamento del vostro Giardino di Legno.

Il Giardino di Legno designs and produces furniture with passion, focusing in particular on woodwork and outdoor materials.

The quiet charisma and the versatile professional skills characterize not only our production but also the support offered to all customers and designers. Our many different abilities combine seamlessly to give birth to great teamwork: we consider every project as a challenge, every request as a mission, every search for a new material as a way to boost and broaden our knowledge and experience.

In our furniture line, different essences, materials and colours are mixed and blended in the creative process so as to offer new solutions and become a source of inspiration when decorating your garden.



CODE0254 SRI00223  
CODE0363 SRI00224  
CODE0489 SRI00225  
CODE0491 SRI00226  
CODE0531 SRI00227  
TILT2501 SRI00229  
SRI00278







CODE0489 SRI00225  
CODE0491 SRI00227  
CODE0531 SRI00229  
TILT2501 SRI00278  
SRI00281





CODE0254	SRI00223
CODE0363	SRI00224
CODE0488	SRI00225
TILT2501	SRI00226
	SRI00227
	SRI00280

CODE0250    SRI00216  
CODE0252    SRI00223  
CODE0253    SRI00224  
CODE0490    SRI00225  
TILT2501    SRI00226  
                  SRI00227  
                  SRI00228  
                  SRI00229  
                  SRI00267  
                  SRI00268  
                  SRI00279









CODE0250    SRI00216  
 CODE0252    SRI00223  
 TILT2501    SRI00225  
                   SRI00226  
                   SRI00227  
                   SRI00228  
                   SRI00229  
                   SRI00267  
                   SRI00268

CODE0253    SRI00223  
 CODE0490    SRI00224  
 TILT2501    SRI00225  
                   SRI00228  
                   SRI00229  
                   SRI00279





CODE0362 SRI00208  
CODE0485 SRI00225  
TILT2501 SRI00226  
SRI00228  
SRI00231  
SRI00232  
SRI00233

SRI00208







RMIX0372  
RADIO495  
TILT2501

SRI00218  
SRI00282

RADIO497  
RMIX0373  
RMIX0535  
TILT2501

SRI00245  
SRI00259



RMIX0372 RMIX0376 RMIX0868 SRI00245  
RMIX0373 RMIX0535 TILT2501 SRI00272







RMIX048A  
RMIX049A  
TILT2501

SRI00211  
SRI00212

RMIX048A  
RMIX049A  
TILT2501

SRI00212  
SRI00213  
SRI00257



RMIX0377  
RMIX0378  
RMIX0534+K01  
TILT2501

SRI00241

RMIX0371  
TILT2501



EMIL0459      SRI00234  
RMIX0369      SRI00248  
RMIX0384      SRI00252  
RMIX0872  
RMIX0873  
TILT2501









RMIX0370  
RMIX0374  
RMIX0499  
RMIX0534+K02  
RMIX0873  
RMIX0874  
TILT2501





TILT2501 SRI00266



ACCC0877

RMIX0869

RMIX0871

TILT2501

SRI00219

SRI00237

SRI00238

SRI00239

SRI00240

SRI00242

SRI00244

BOXR0255  
BOXR0364  
BOXR0492  
BOXR0493  
BOXR0533  
TILT2501

SRI00210  
SRI00253











BOXR0365  
RMIX041A  
TILT2501

SRI00275  
SRI00277

BOXR0492

RADIO248  
RMIX048A  
RMIX049A  
TILT2501

SRI00211  
SRI00214  
SRI00215  
SRI00217  
SRI00256  
SRI00258





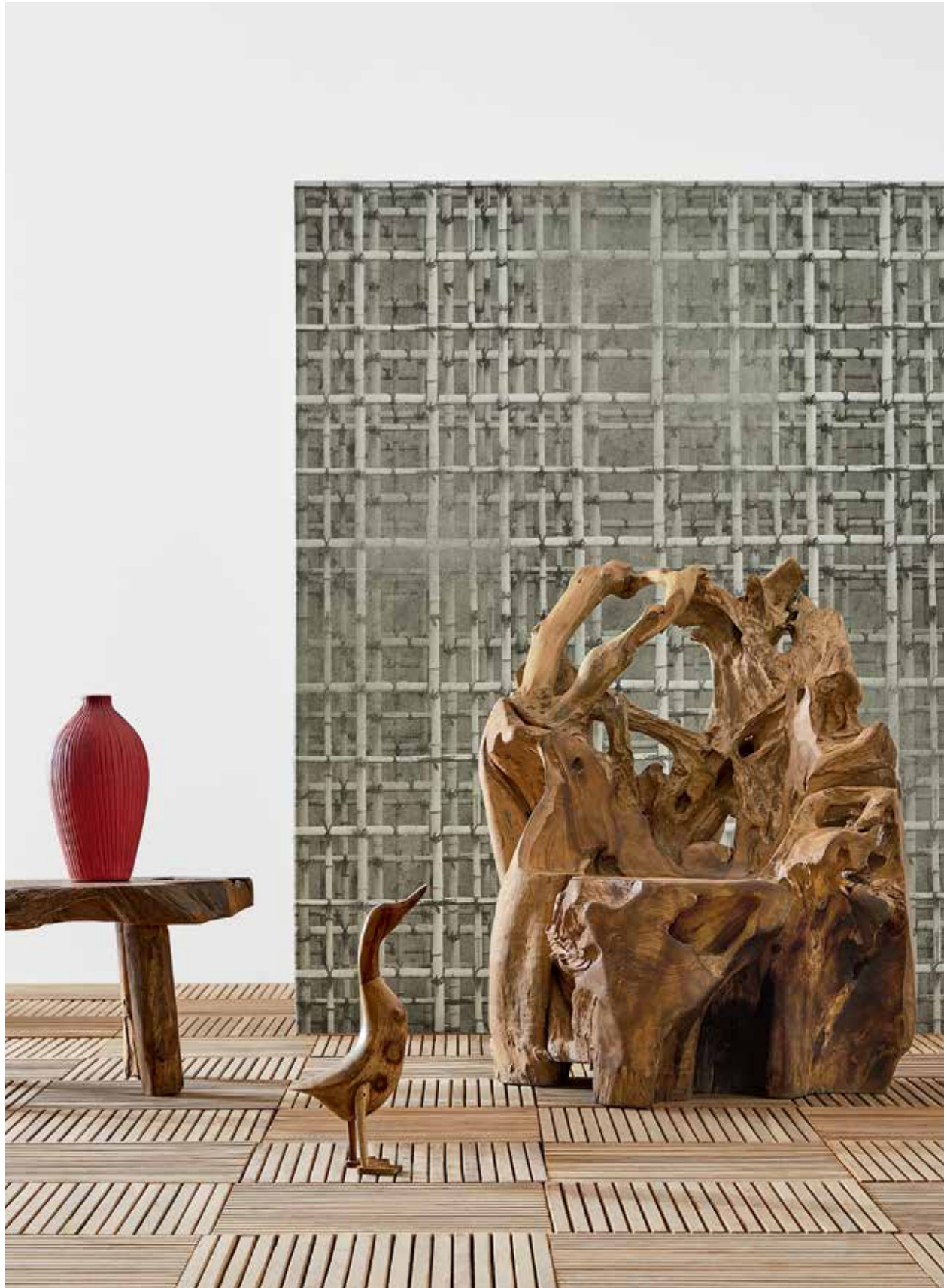

RADI0366  
RADI0494  
TILT2501

RADI0367    SRI00251  
RADI0498    SRI00264  
TILT2501





RADI0368  
RMIX042A  
RMIX043A  
TILT2501

RADI0368  
RMIX042A  
RMIX043A  
RMIX044A  
TILT2501



ACCV4804    PILW6060  
CINE0256    SRI00249  
CINE0536    SRI00255  
CINE0538  
CINE0542  
CINE0545  
CINE0546  
CINE0876  
RMIX047A  
TILT2501







CINE0380  
CINE0382  
CINE0538  
CINE0543  
RMIX0867  
TILT2501  
SRI00222



CINE0383 PILW5050  
CINE0537 PILW6060  
CINE0875 SRI00269  
TILT2501 SRI00270  
SRI00271





CINE0381  
CINE0383  
CINE0539  
CINE0540  
CINE0541  
CINE0542  
CINE0875  
TILT2501  
PILW6060  
SRI00269  
SRI00270  
SRI00271







# BOXER

design by CAMILLA LAPUCCI E LAPO BIANCHI LUCI

Collezione realizzata interamente in legno di teak con finitura a levigatura fine naturale Fine Sanded. I diversi tipi di mobili che la costituiscono sono tutti caratterizzati da forme sobrie e squadrate. Divani e poltrone di diverso tipo con linee semplici e geometriche adatte ad ogni ambiente. Tavolini in due misure e lettino da sole completano la collezione, pensata per spazi esterni contract o privati, anche di dimensioni contenute.

Different types of furniture are part of this collection, entirely made of teak wood with Fine Sanded finishing. They are all characterized by sober and squared shapes. Designed for terraces or balconies, even the small ones, the benches, lounge chairs and sunbeds of the Boxer collection feature simple and geometric lines.

BOXR0255 + BOXR0255-CUS



BOXR0255



BOXR0364 + BOXR0364-CUS



BOXR0364



BOXR0365



BOXR0365 + BOXR0365-CUS



BOXR0365





BOXR0255

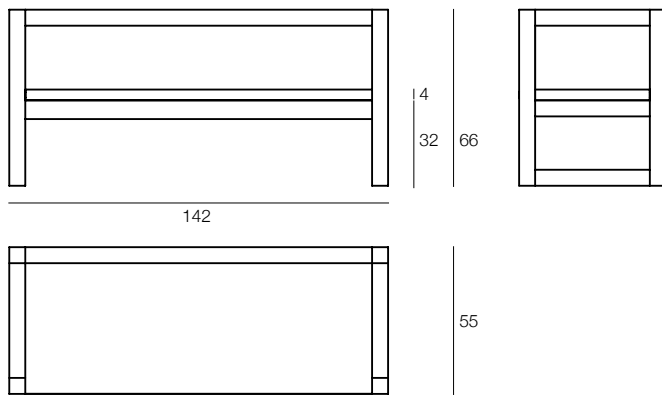

BOXR0364

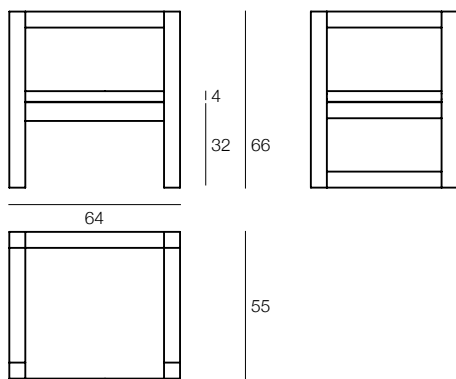

BOXR0365

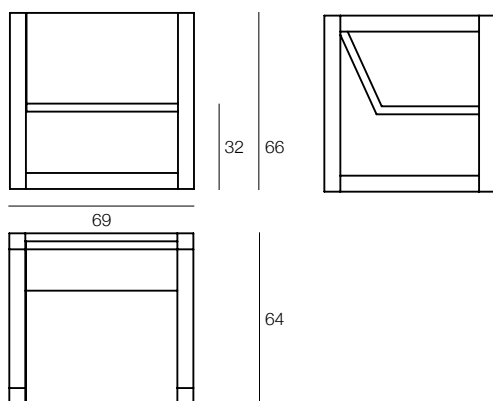

BOXR0492



BOXR0493



BOXR0533 + BOXR0533-CUS



BOXR0533



BOXR0492

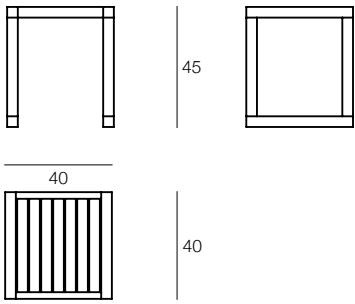

BOXR0493

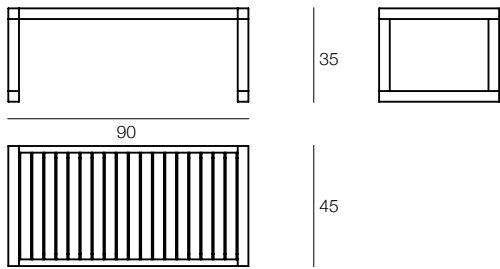

BOXR0533

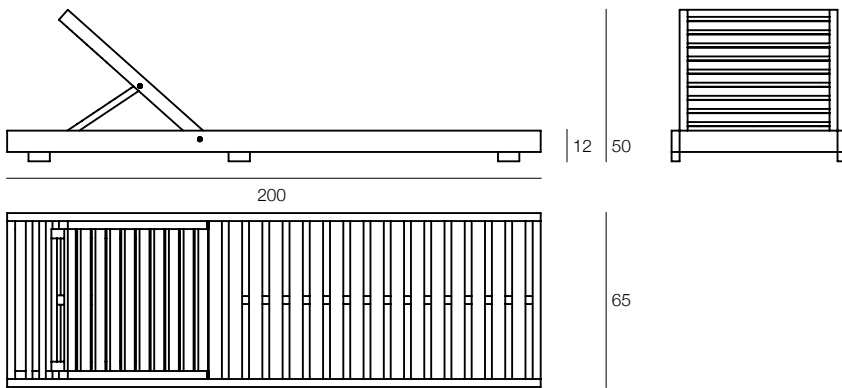

# CINÉMA D'ÉTÉ

design by CAMILLA LAPUCCI E LAPO BIANCHI LUCI + CRS Silat

Struttura di panche e sedute in legno di teak a finitura oliata, con intreccio in rattan sintetico nero (Black) e bianco (Ice White), alternati in un motivo a spina di pesce. Cuscini "pouf" con struttura in alluminio e poliuretano drenante. Cuscini da pavimento con imbottitura in polistirene espanso oppure in gommapiuma ecologica, in quanto ottenuta da ritagli avanzati da altre lavorazioni che altrimenti andrebbero sprecati. Rivestimento esterno standard in tessuto acrilico Canvas Ecrù.

Benches and chairs frame are made of teak wood with oil finishing, while the seats and the backseats of the chairs are made of fishbone woven black and ice white synthetic rattan, to create alternated geometric patterns. A series of "pouf" cushions for outdoor and garden are also part of the Cinema d'été collection: made with aluminium frame covered with open cell polyurethane. Floor pillow are available with filling in styrofoam, while some other with the trimmings left from the processing of the polyurethane foam. In both cases, the standard external upholstery is in Ecrù Canvas.

CINE0380



CINE0256



CINE0257



CINE0381



CINE0382



CINE0383



CINE0536



CINE0536



CINE0537



CINE0380

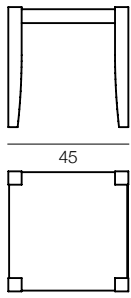

CINE0256

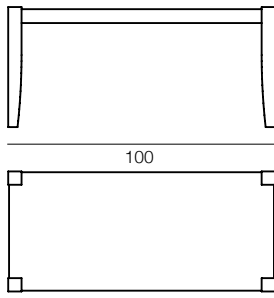

CINE0257

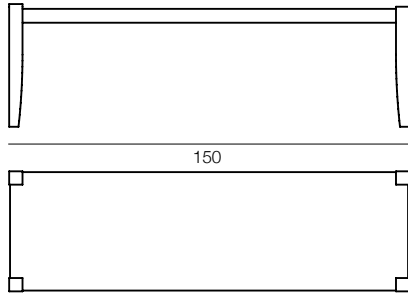

CINE0256-0257-0380

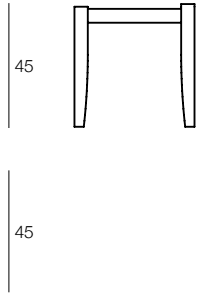

CINE0381

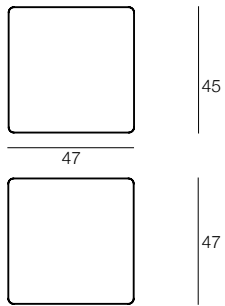

CINE0382

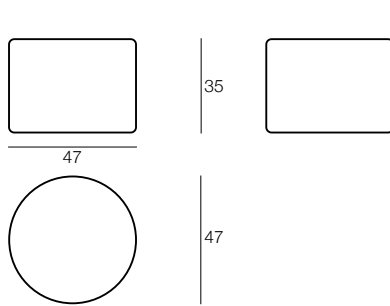

CINE0383

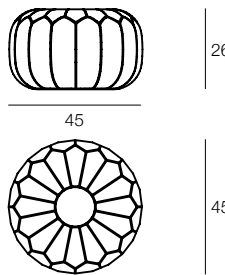

CINE0536

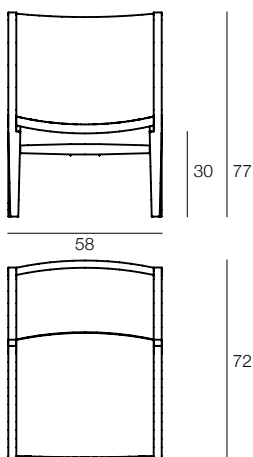

CINE0537

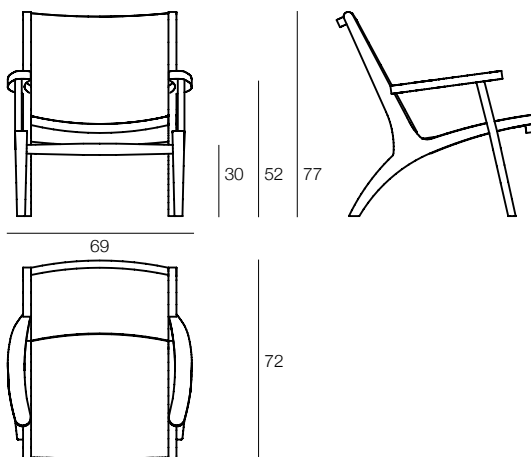

CINE0538 + CINE0538-CUS



CINE0539



CINE0540



CINE0538

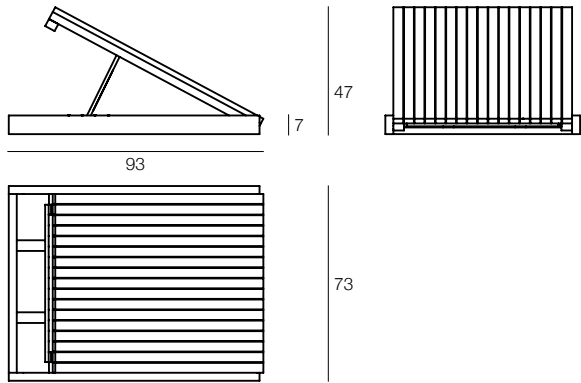

CINE0539

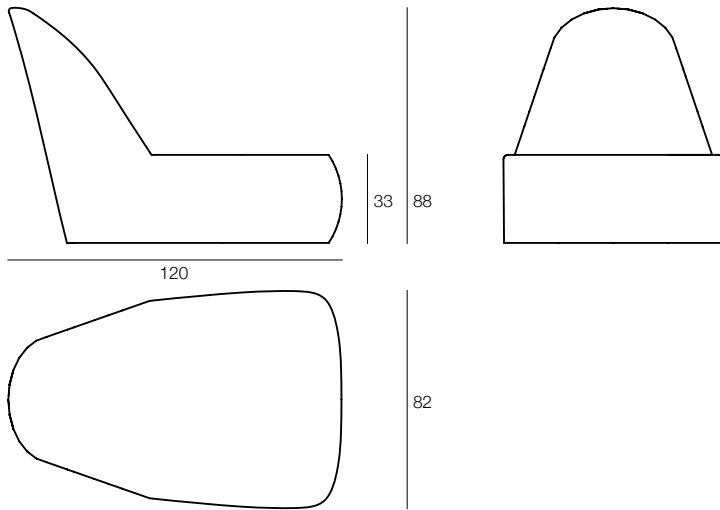

CINE0540

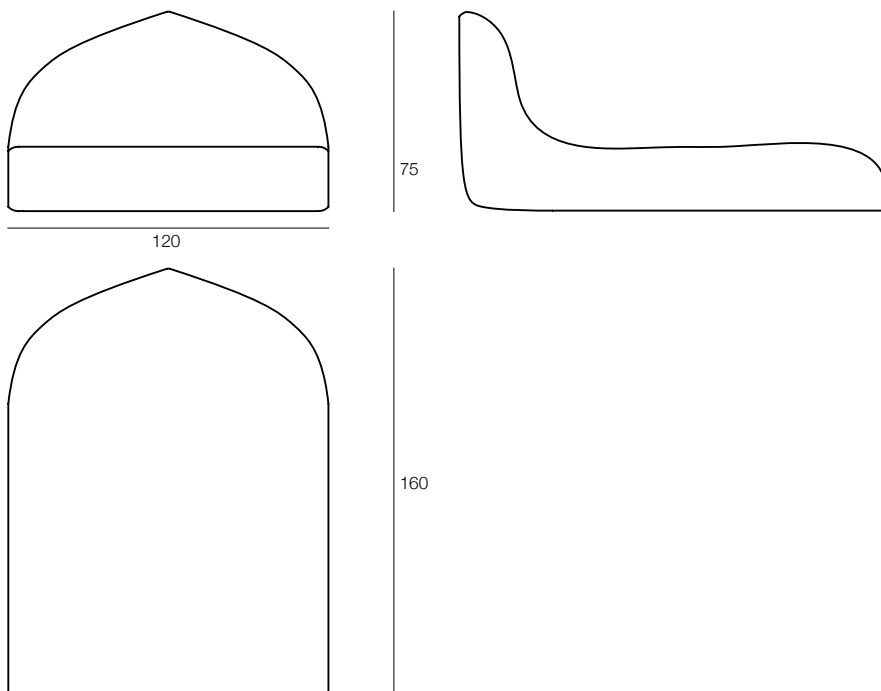

CINE0541-CINE0542



CINE0544-CINE0876



CINE0543



CINE0545



CINE0546



CINE0875





CINE0541-CINE0542

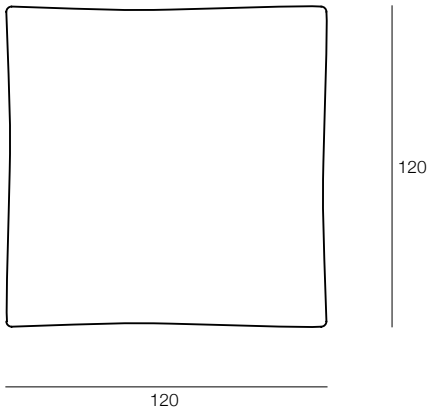

CINE0544-CINE0876

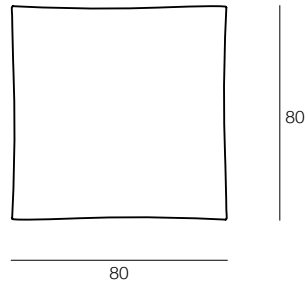

CINE0543

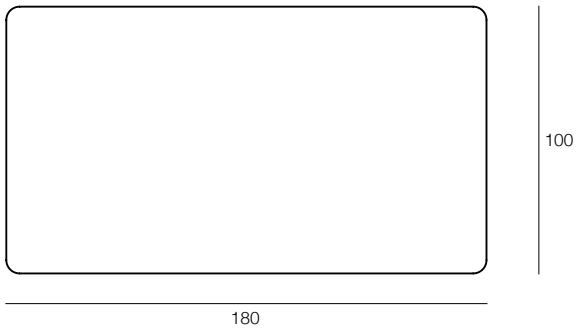

CINE0545

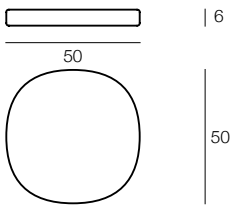

CINE0546

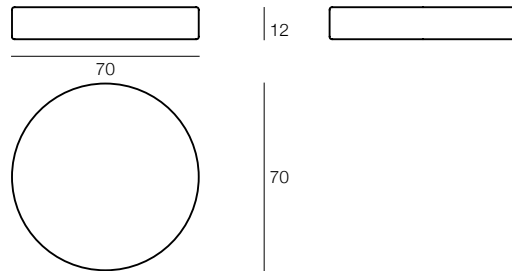

CINE0875

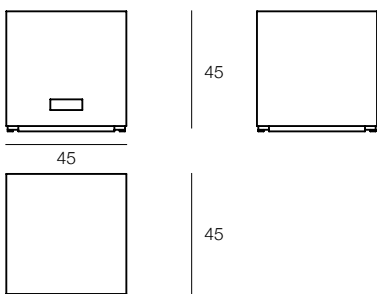

# CODE

design by CAMILLA LAPUCCI E LAPO BIANCHI LUCI

Struttura in legno di teak con finitura standard Fine Sanded a levigatura fine. I listelli in teak sono disposti in modo non simmetrico, con alcuni listelli più vicini tra loro e altri più lontani: in questo modo viene ricreato l'effetto del "codice a barre" (bar code) da cui la collezione trae il nome. I piani dei tavoli sono in marmo bianco, disponibile in varie forme e dimensioni a seconda del modello, o in teak.

The line is composed by pieces of furniture with a Fine Sanded teak wood structure. The teak slats are positioned in an asymmetric way: some of them are closer each other and some other are farther to create a "bar code" effect, after which the collection is named. The table tops are in teakwood or in white marble and are available in different shapes and dimensions, according to the model.

CODE0250 + CODE0250-CUS



CODE0252 + CODE0252-CUS



CODE0253 + CODE0253-CUS



CODE0250

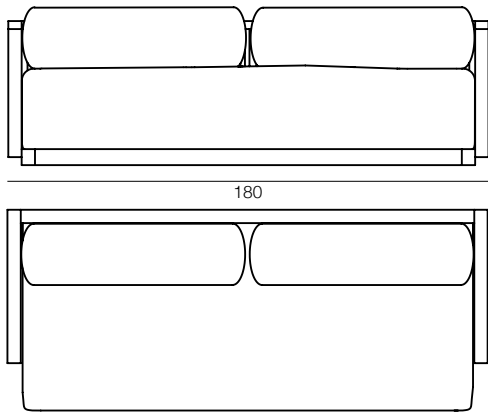

CODE0252

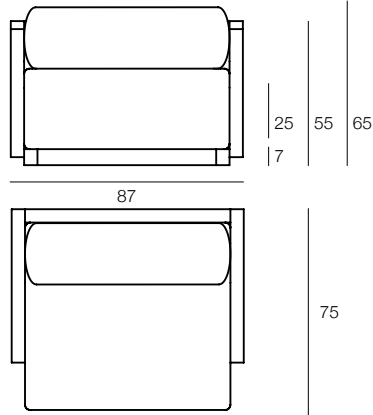

CODE0250-0252

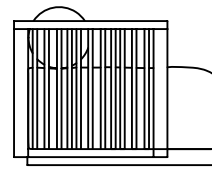

CODE0251

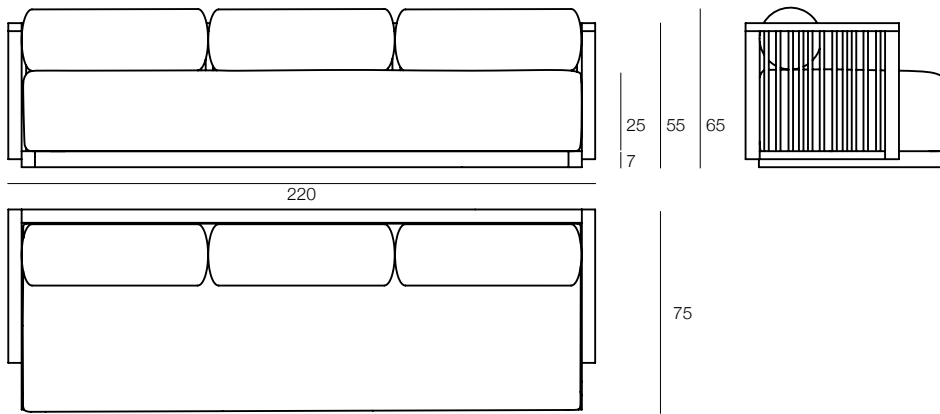

CODE0253

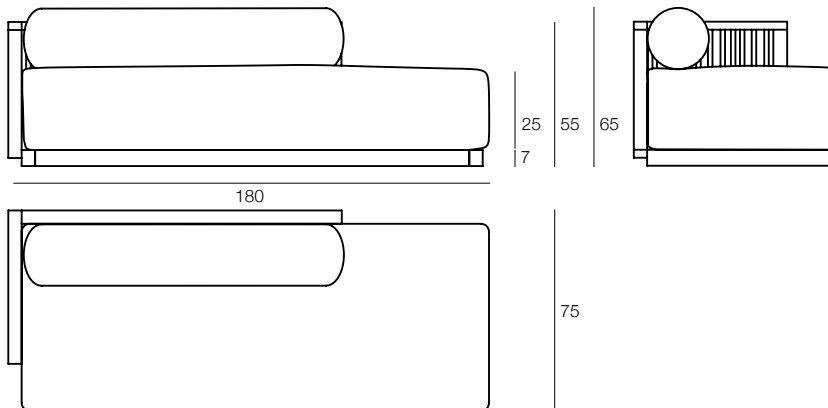

CODE0254 + CODE0254-CUS



CODE0363 + CODE0363-CUS



CODE0488



CODE0489



CODE0490



CODE0491



CODE0254

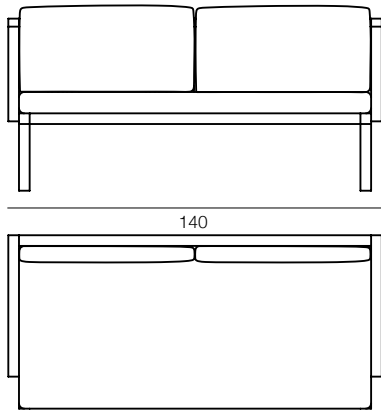

CODE0363

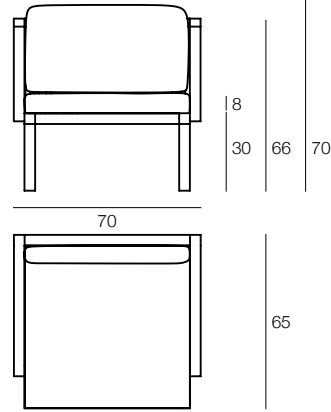

CODE0254-0363

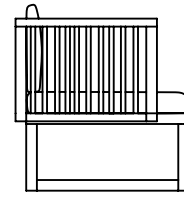

CODE0488

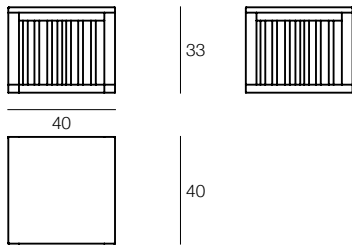

CODE0489

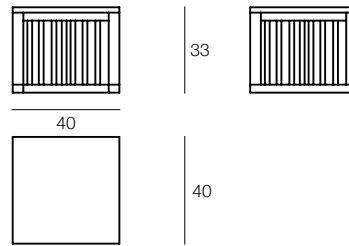

CODE0490

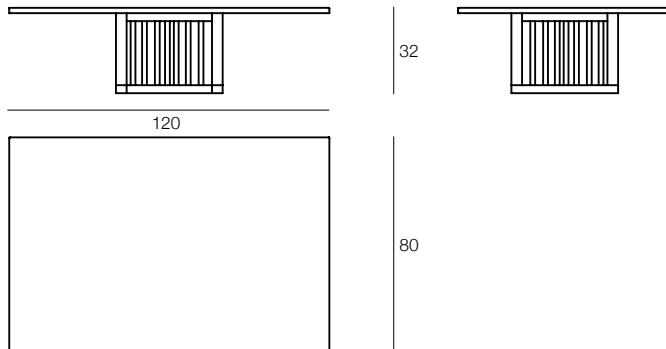

CODE0491

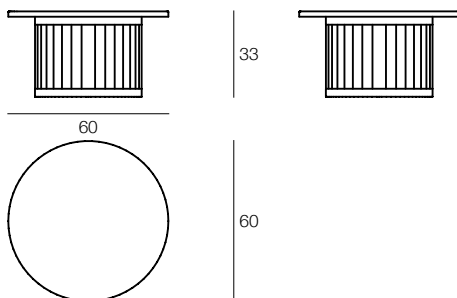

CODE0362 + CODE0362-CUS



CODE0362



CODE0484



CODE0487



CODE0485



CODE0362

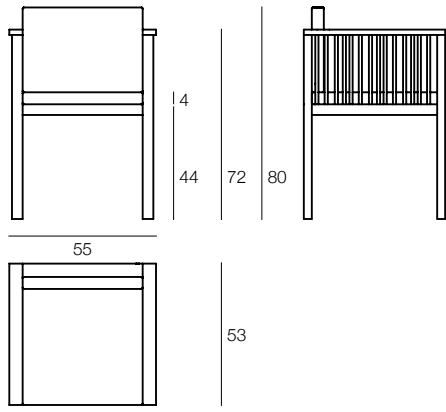

CODE0484

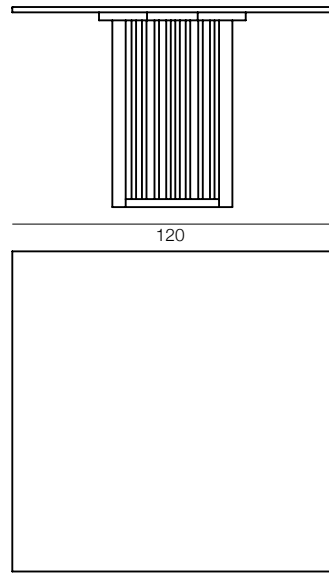

CODE0487

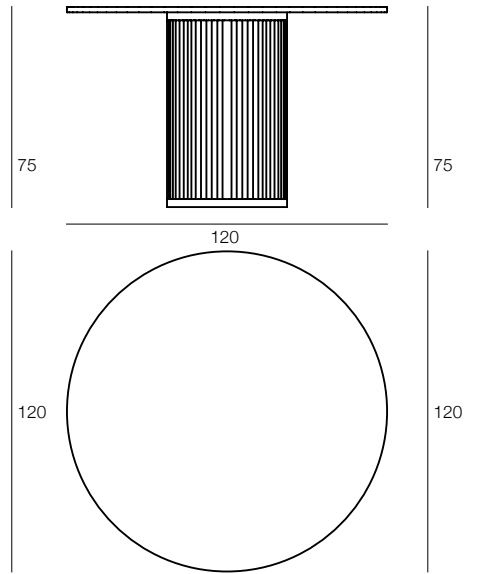

CODE0485

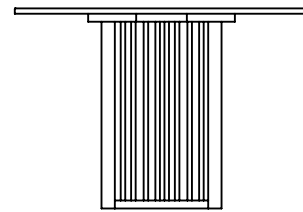
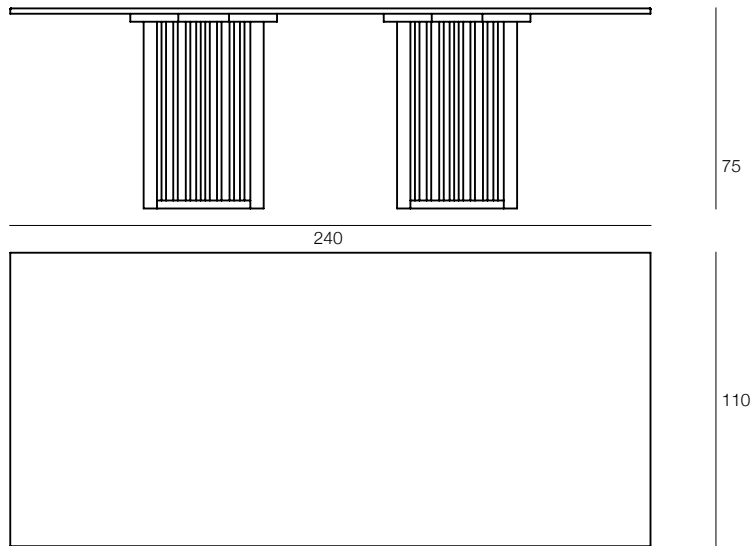

CODE0486

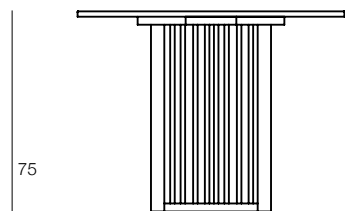
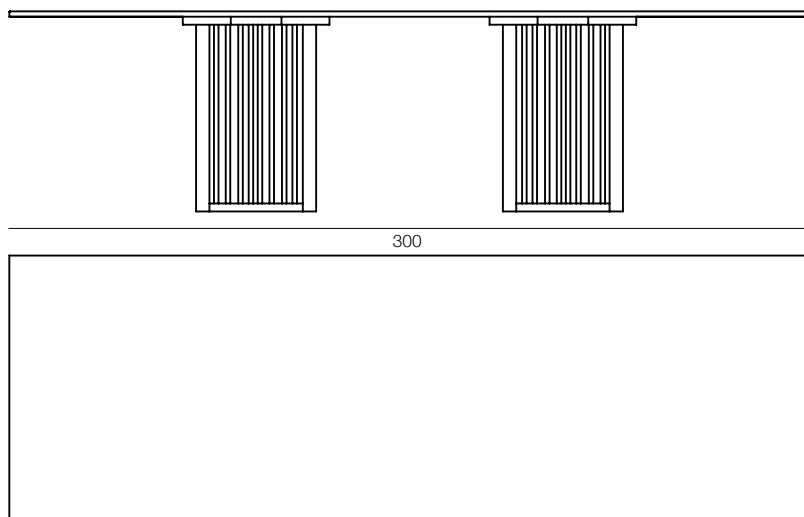

CODE0531 + CODE0531-CUS



CODE0531-0532

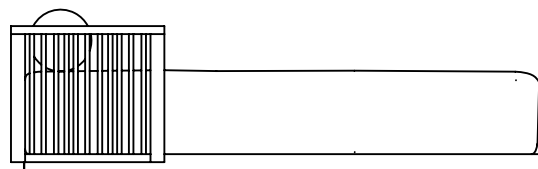

200

25  
55  
7

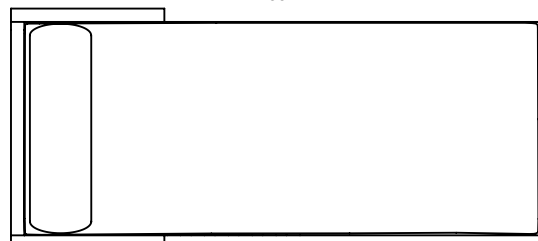

90

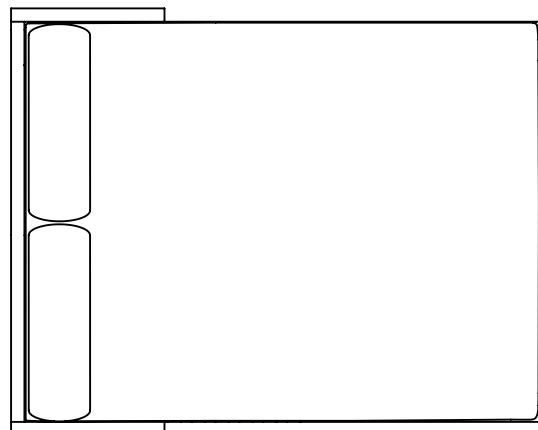

160

CODE0531

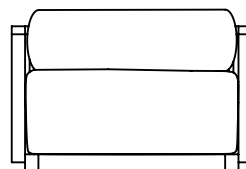

CODE0532

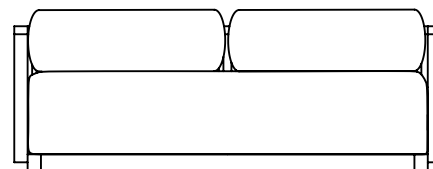



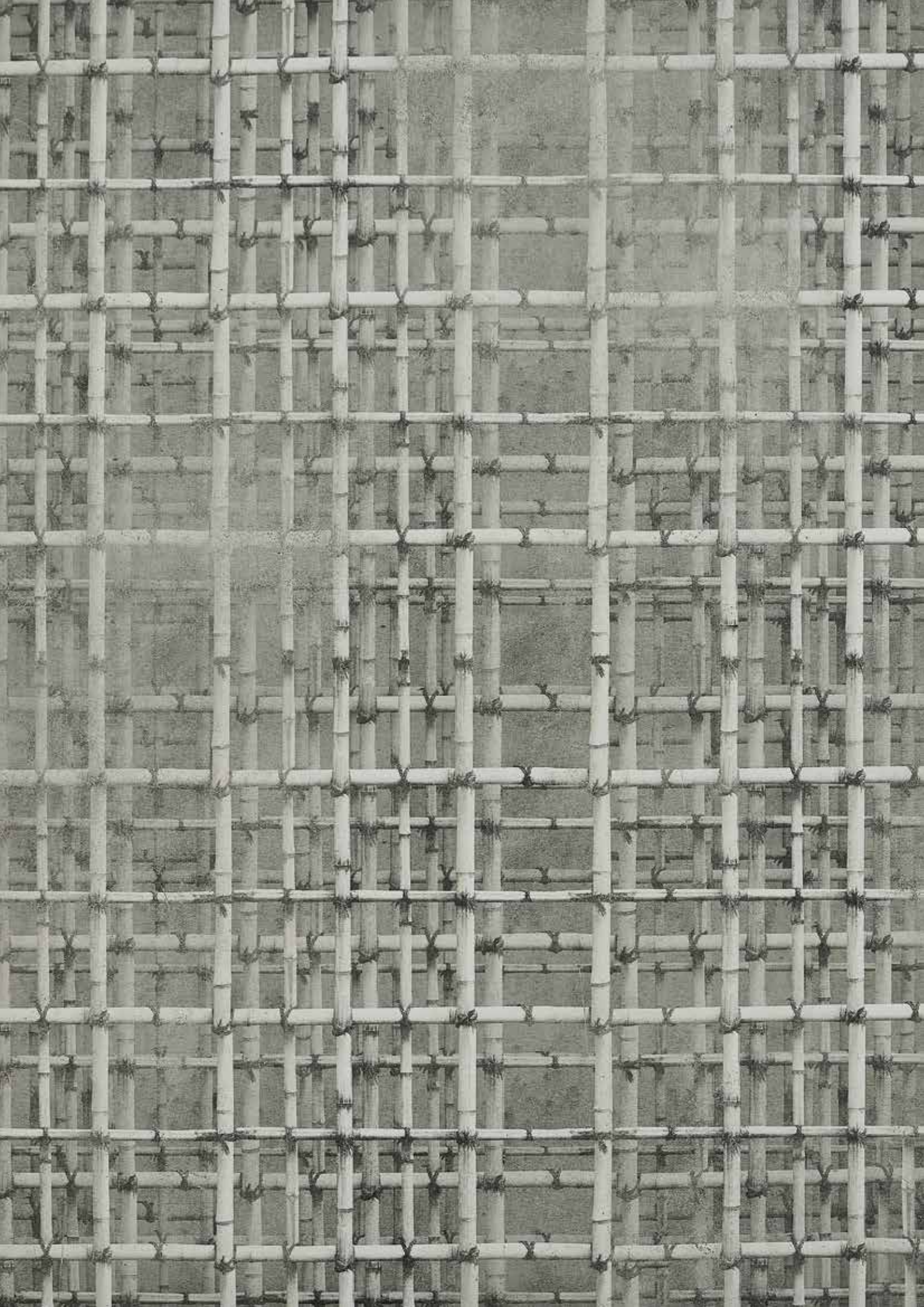

# RADICE

design by NATURE

Queste panche di Teak sono oggetti unici, recuperati dalle radici e da tronchi usurati dal tempo e rifiniti seguendo la loro natura. Proposti in finitura protettiva.

Dimensioni:

Sedia RADIO246 ca 100cm

Panca RADIO247 max 135cm

Panca RADIO248 135-155cm

Panca RADIO249 >155cm

Teak benches with unique shapes, recovered from naturally worn roots and logs, well-finished following their natural elements. Standard version with a layer of protective finishing.

Dimentionis:

Chair RADIO246 ca 100cm

Bench RADIO247 max 135cm

Bench RADIO248 135-155cm

Bench RADIO249 >155cm

RADIO366



RADIO366



RADIO494



RADIO246



RADIO247



RADIO366

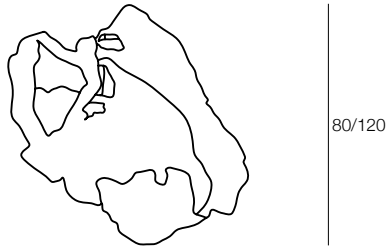
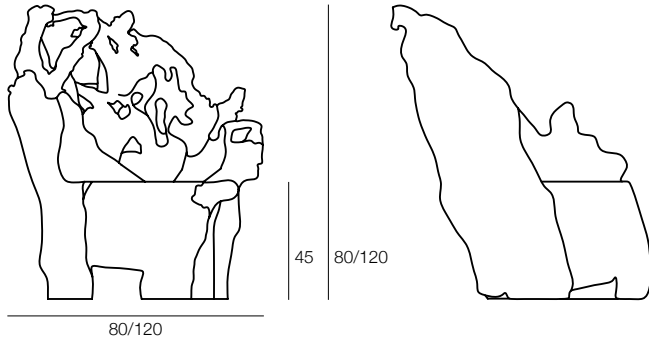

RADIO494

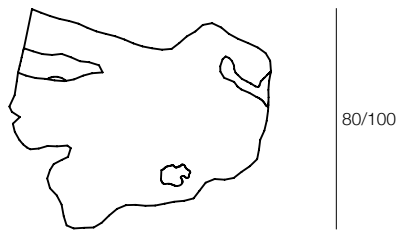
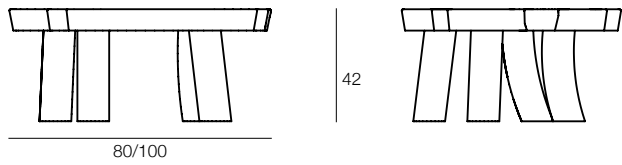

RADIO248



RADIO249



RADIO360



RADIO495



RADIO496



RADIO497



RADIO368



RADIO367



RADIO498



RADIO360

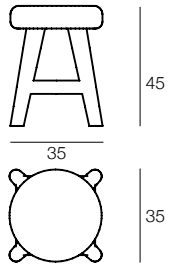

RADIO495

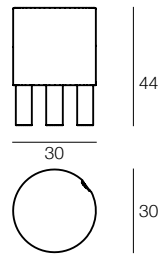

RADIO496

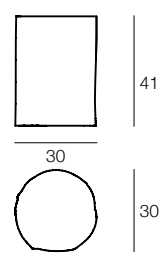

RADIO497

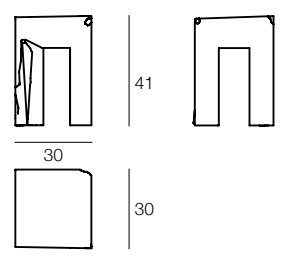

RADIO367

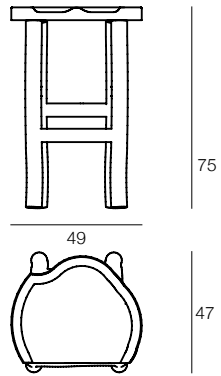

RADIO368

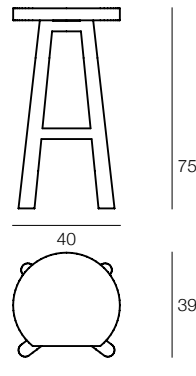

RADIO498

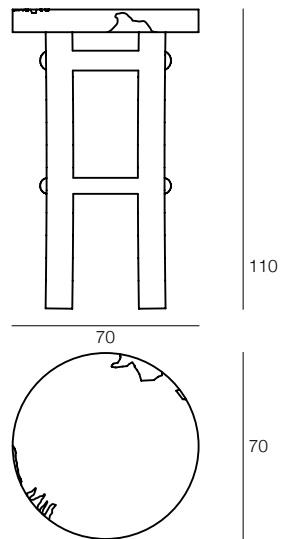

# REMIX

design by CAMILLA LAPUCCI E LAPO BIANCHI LUCI

Molteplici materiali sono utilizzati per questa collezione che vuole unire stili e design differenti. La linea presenta numerosi prodotti fatti da più materiali, anche molto diversi tra loro, uniti da un design armonico e unitario. Le sedie in rattan, di varie forme e dimensioni, sono a finitura non pigmentata semi-lucida e con le gambe in metallo verniciato a polveri. La collezione presenta anche rivisitazioni della classica "sedia danese" e della "tripolina" con sedute in pelle o in tessuto. Accessori, vasi e tavolini vengono creati con diversi tipi di legno: il teak e il suar, ma anche il mogano e il legno di palma, con finiture protettive o finitura nera per un effetto particolare e molto decorativo.

Several materials are used for this collection that aims to combine different styles and designs. The lines present different products made of various materials, very different from each other, but joined together by a harmonic and unitary design. The chairs are made of rattan and available in different shapes and dimensions, with semi-gloss non-pigmented finishing and legs in powder coated metal. The classical "Danish chair" and "Tripolina butterfly chair" have been revisited in this collection with seats in leather or fabric. Accessories, flowerpots and coffee tables are created with different types of wood: teak and suar, but also mahogany and palm wood, with protective finishing or black finishing for a peculiar and very decorative effect.

RMIX0369



RMIX0370



RMIX0371



RMIX0372



RMIX0369

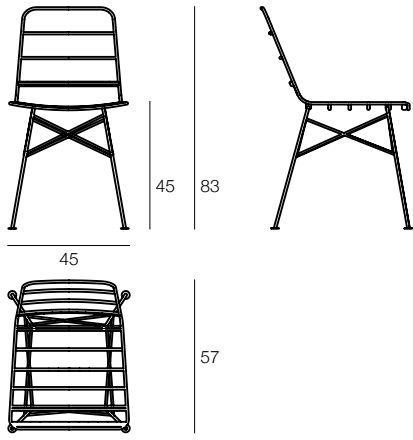

RMIX0370

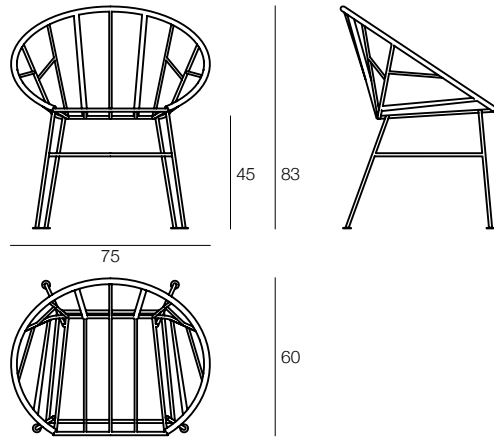

RMIX0371

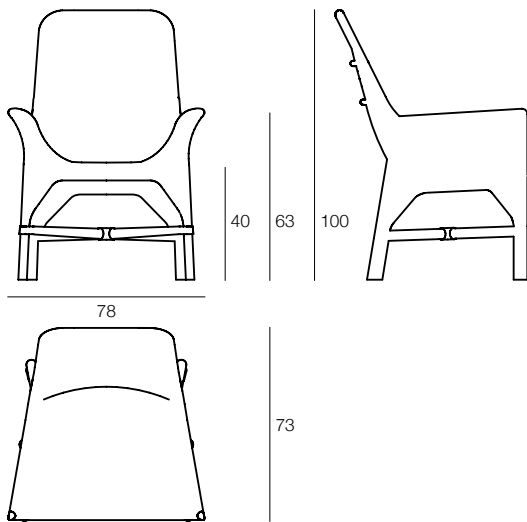

RMIX0372

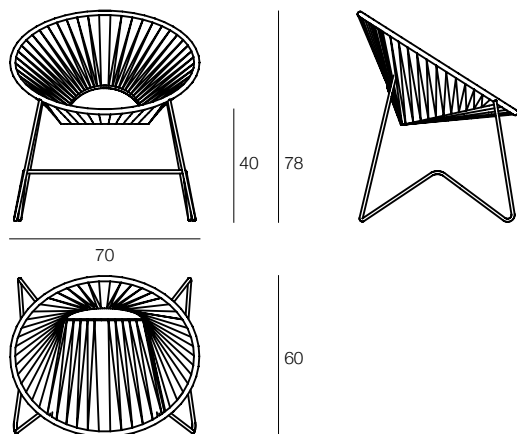

RMIX0373



RMIX0374



RMIX0375



RMIX0376



RMIX0377



RMIX0378





RMIX0373

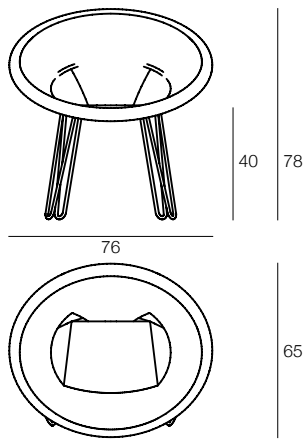

RMIX0374

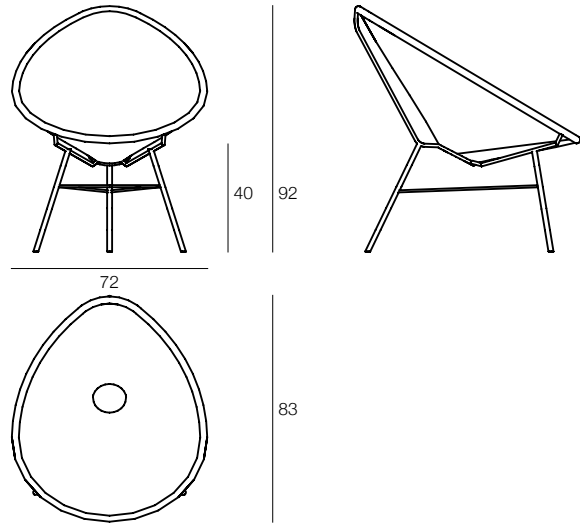

RMIX0375

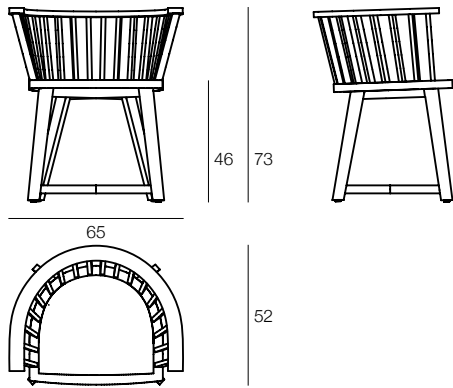

RMIX0376

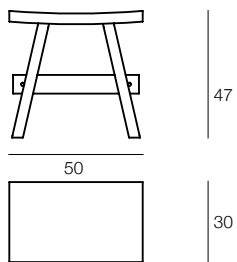

RMIX0377

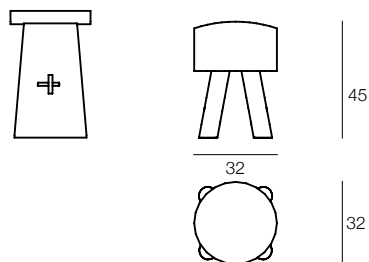

RMIX0378

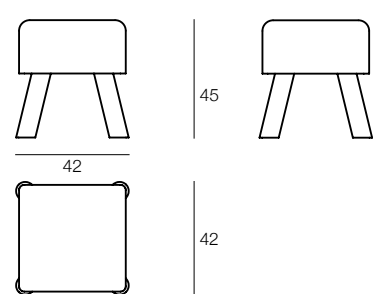

RMIX0379



RMIX0384



RMIX041A



RMIX041A



RMIX041A



RMIX042A-RMIX043A-RMIX044A



RMIX045A-RMIX046A-RMIX047A



RMIX0379

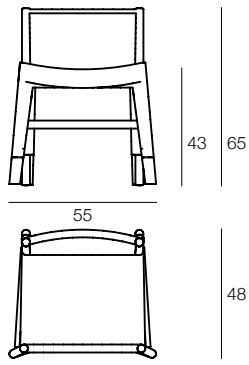

RMIX0384

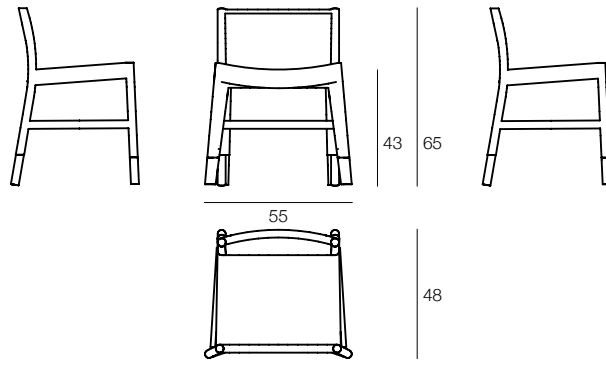

RMIX041A

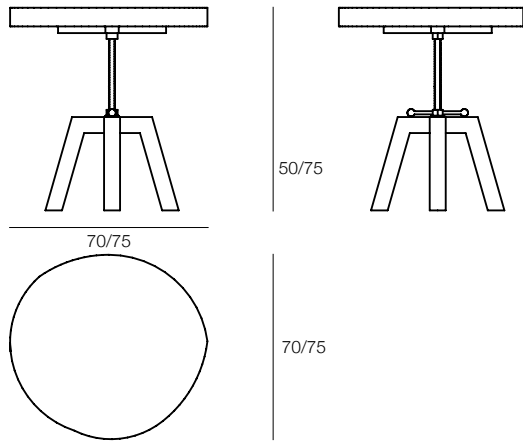

RMIX042A

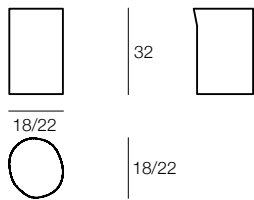

RMIX043A

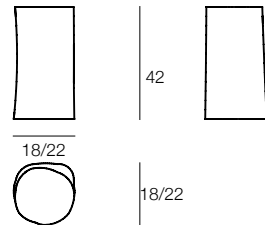

RMIX044A

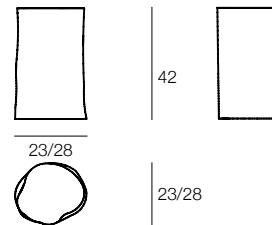

RMIX045A

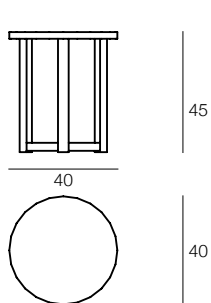

RMIX046A

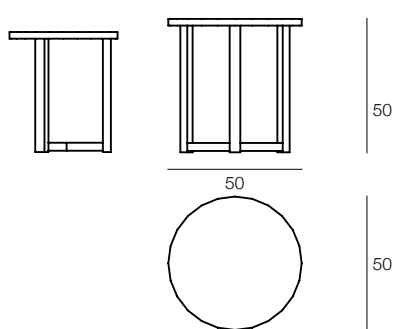

RMIX047A

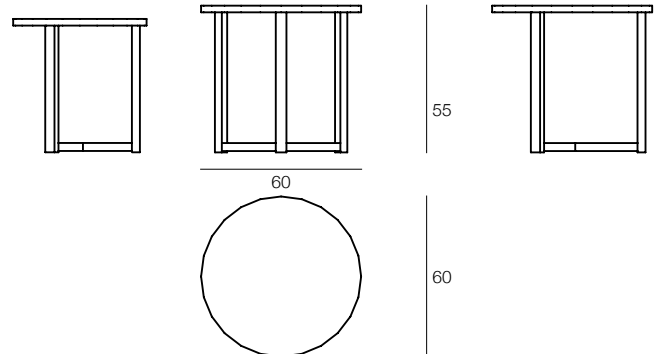

RMIX048A



RMIX049A



RMIX0499



RMIX0534+K01



RMIX0534+K02



RMIX0535



RMIX048A

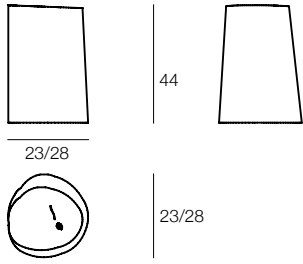

RMIX049A

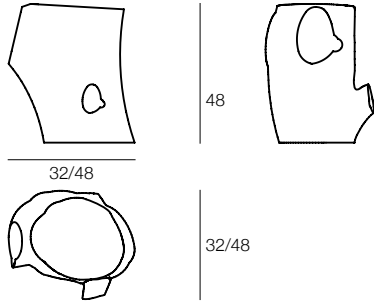

RMIX0499

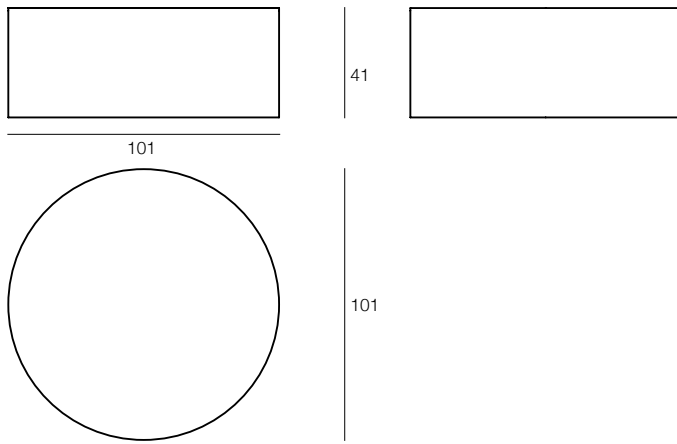

RMIX0534

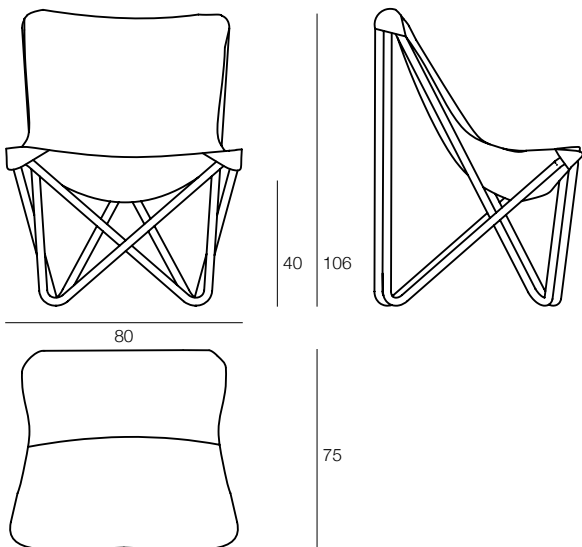

RMIX0535

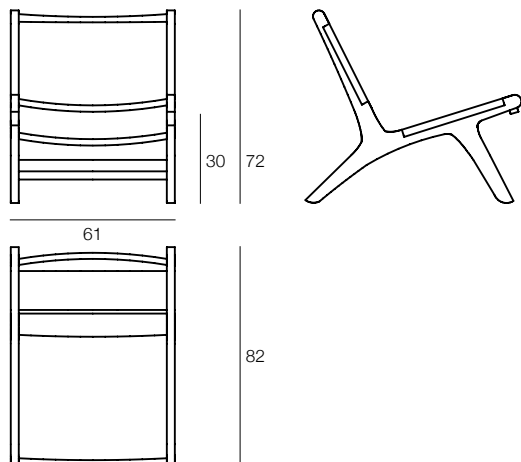

RMIX0867



RMIX0868



RMIX0869



RMIX0870



RMIX0871



RMIX0872-0873-0874



RMIX0867

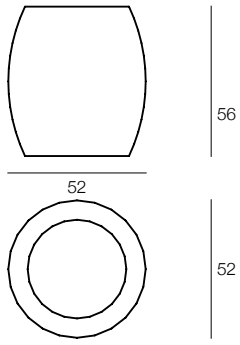

RMIX0868

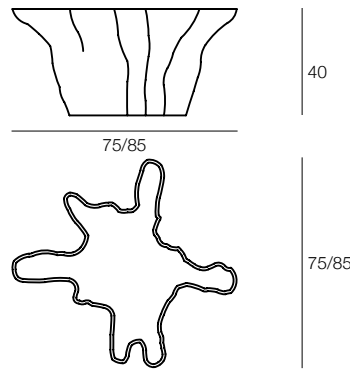

RMIX0869

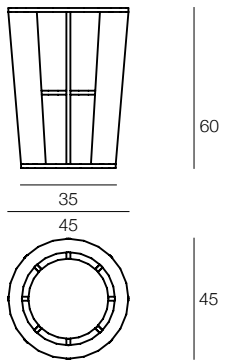

RMIX0870

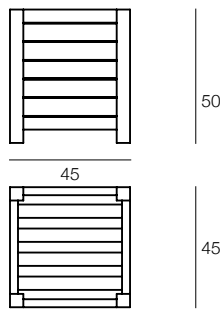

RMIX0871

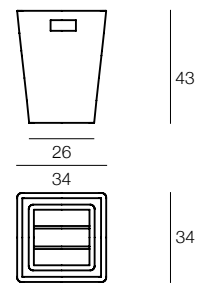

RMIX0872

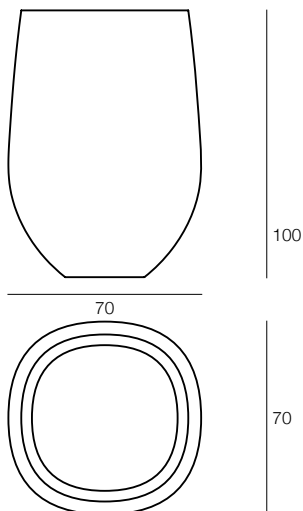

RMIX0873

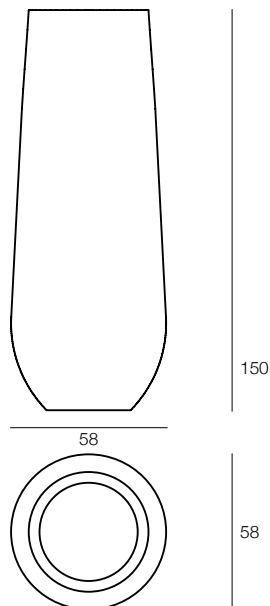

RMIX0874

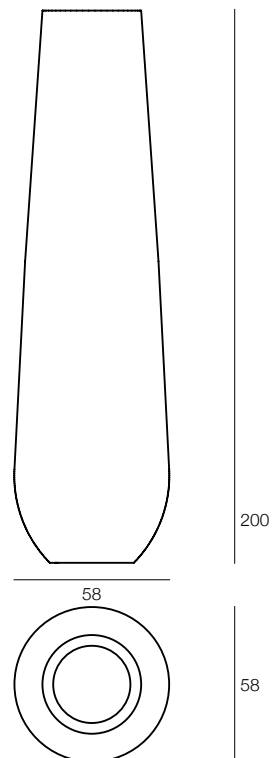

# DECOR

design by CAMILLA LAPUCCI E LAPO BIANCHI LUCI

Raccolta di oggetti decorativi realizzati in legno di teak, intrecciati in vimine "Kubu Gray" colorata con un metodo tradizionale e totalmente naturale, oggetti realizzati intagliando radici o scavando tronchi lasciati con la sua naturale corteccia. Vasi in legno o in ceramica. Cesti in fibra sintetica mono o bi-colore, sfere in corteccia di bambou, tavolini e vasi in cemento.

Decorative objects made from teak wood. Baskets made of woven "Kubu Gray" wicker: a natural fibre dyed using traditional, natural methods. Bowls and centerpieces are created from carved teakwood logs with natural bark. Ceramic or wooden decorative vases and bottles. Unichrome or two tone synthetic fiber storage baskets. Bamboo skin balls. Cement vases and side tables.

ACCC0877 + ACCC0843-CUS



ACCC0843 + ACCC0843-CUS



SRI00208



SRI00209



SRI00210



SRI00211





ACCC0877

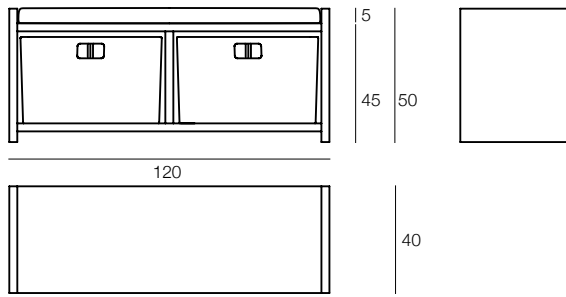

ACCC0843

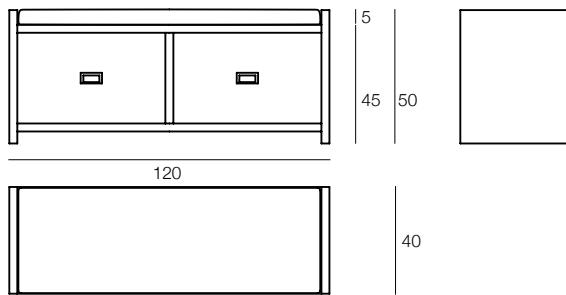

SRI00208

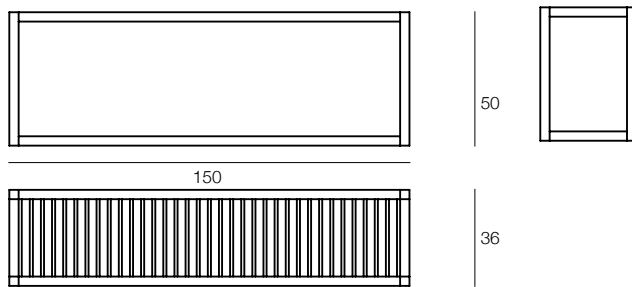

SRI00209

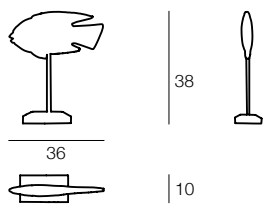

SRI00210

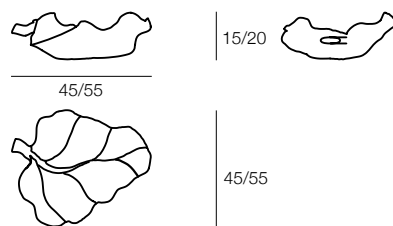

SRI00211

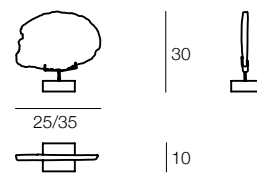

SRI00212-SRI00213-SRI00214



SRI00215



SRI00216



SRI00217



SRI00218



SRI00219



SRI00220



SRI00221



SRI00222



SRI00234



SRI00212

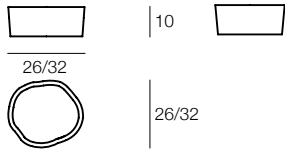

SRI00213

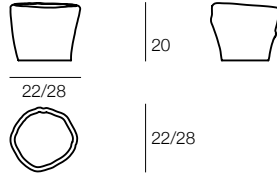

SRI00214

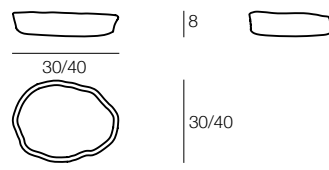

SRI00215

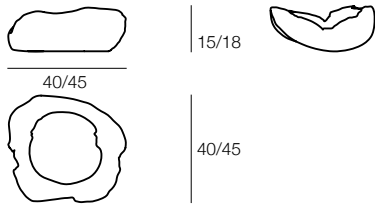

SRI00216

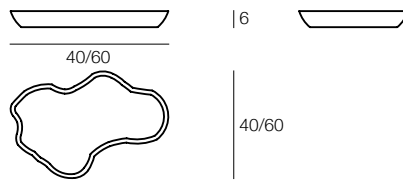

SRI00217

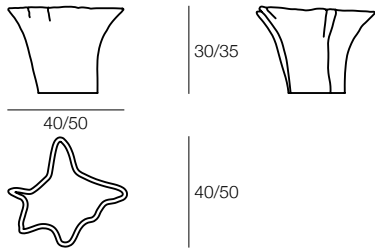

SRI00218

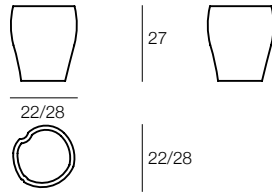

SRI00219

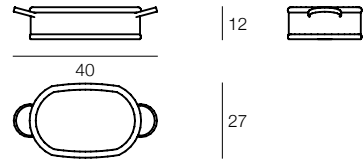

SRI00220

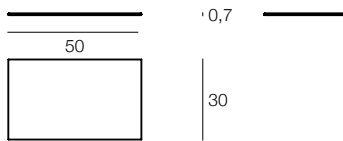

SRI00221

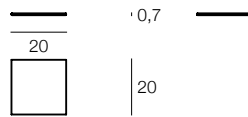

SRI00222

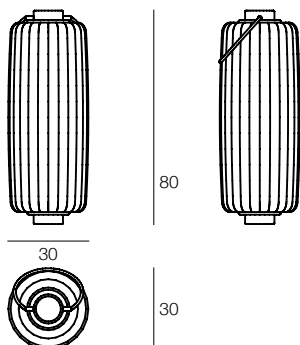

SRI00234

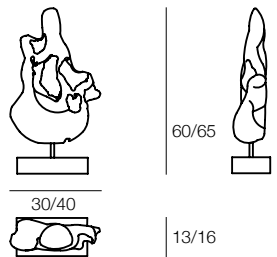

SRI00224 - SRI00225  
SRI00223



SRI00226 - SRI00227



SRI00228 - SRI00229



SRI00230 - SRI00231 - SRI00232 - SRI00233



SRI00235



SRI00236



SRI00237



SRI00238



SRI00239



SRI00240



SRI00241



SRI00242



SRI00243



SRI00223

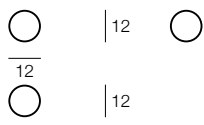

SRI00224

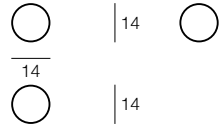

SRI00225

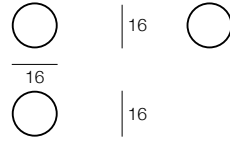

SRI00226

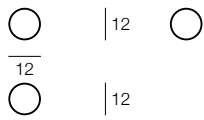

SRI00227

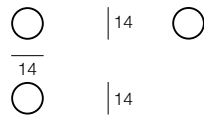

SRI00228

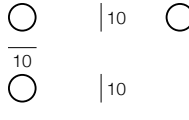

SRI00229

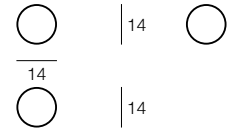

SRI00230

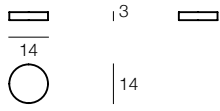

SRI00231

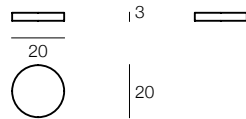

SRI00232

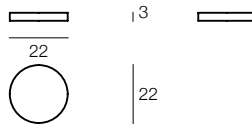

SRI00233

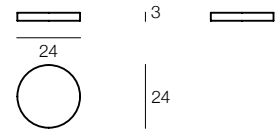

SRI00235

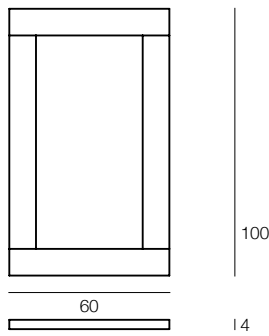

SRI00236

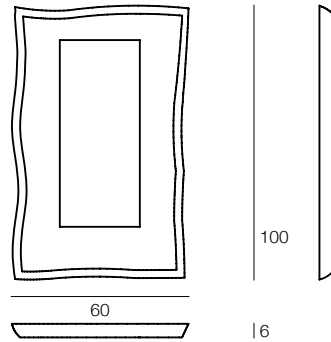

SRI00237

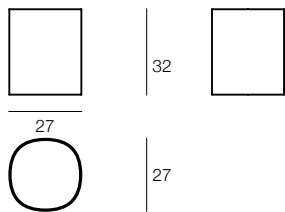

SRI00238

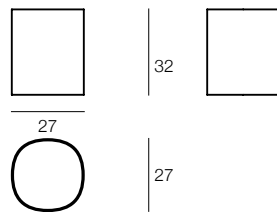

SRI00239

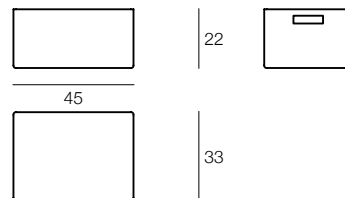

SRI00240

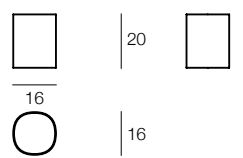

SRI00241

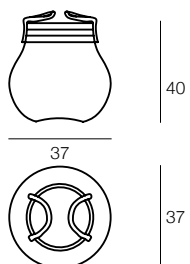

SRI00242

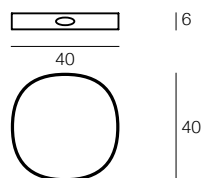

SRI00243

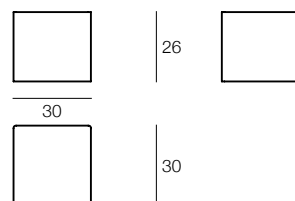

SRI00244



SRI00245



SRI00245



SRI00246



SRI00247



SRI00248



SRI00249



SRI00250



SRI00251



SRI00252



SRI00253



SRI00254 - SRI00255



SRI00256



SRI00257



SRI00258



SRI00259



SRI00244

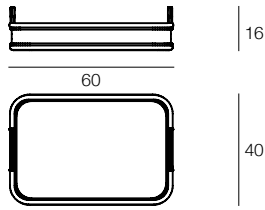

SRI00245

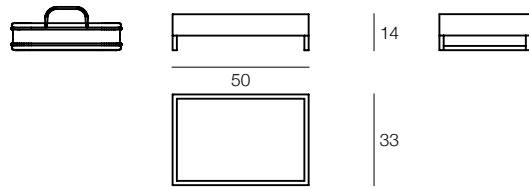

SRI00246

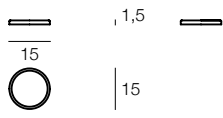

SRI00247



SRI00248

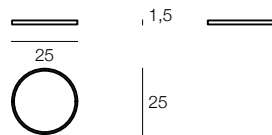

SRI00249

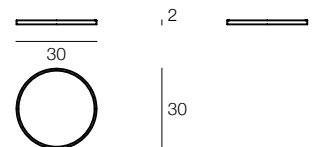

SRI00250

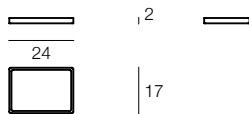

SRI00251

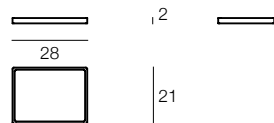

SRI00252

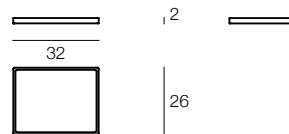

SRI00253

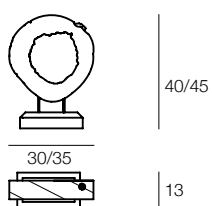

SRI00254

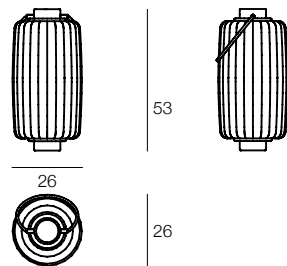

SRI00255

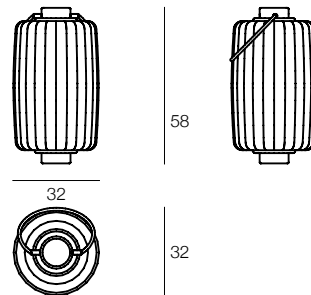

SRI00256

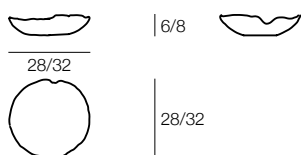

SRI00257



SRI00258

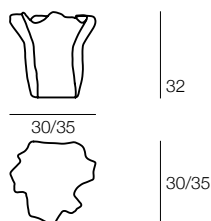

SRI00259

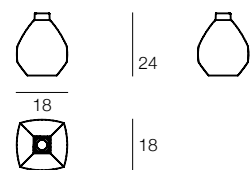

SRI00262



SRI00263



SRI00264



SRI00265



SRI00266



SRI00267



SRI00268





SRI00262

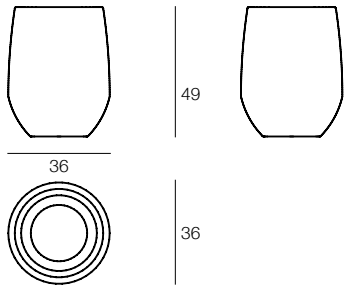

SRI00263

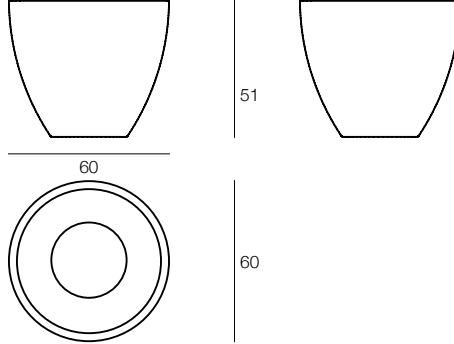

SRI00264

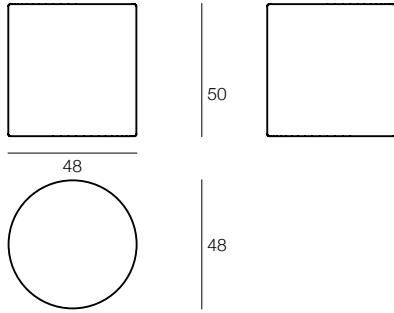

SRI00265

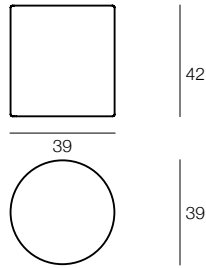

SRI00266

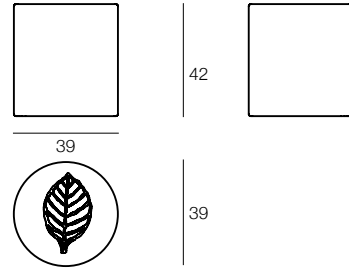

SRI00267

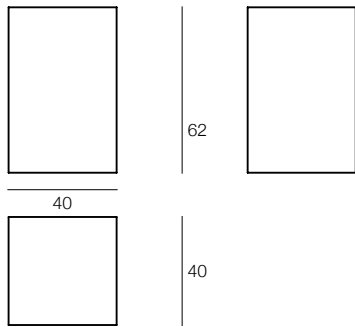

SRI00268

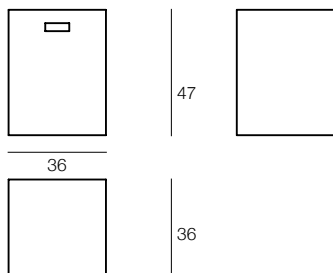

SRI00269



SRI00270



SRI00271



SRI00272



SRI00273



SRI00274



SRI00278



SRI00279



SRI00280



SRI00281



SRI00269

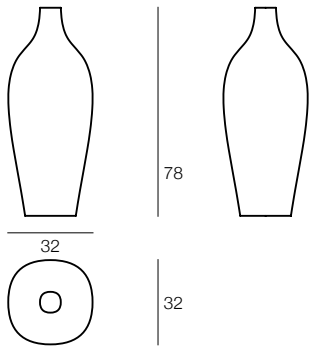

SRI00270

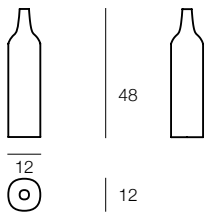

SRI00271

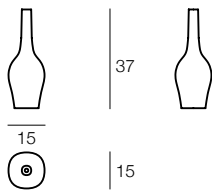

SRI00272-275

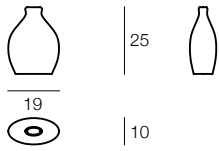

SRI00273-276

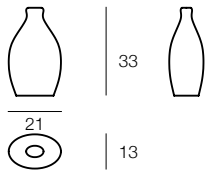

SRI00274-277

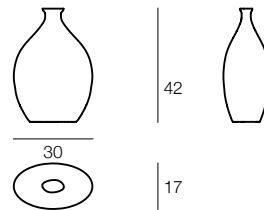

SRI00278

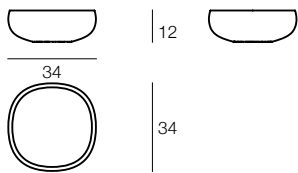

SRI00279

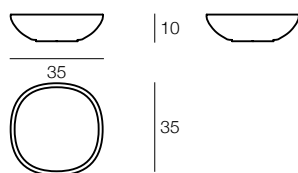

SRI00280

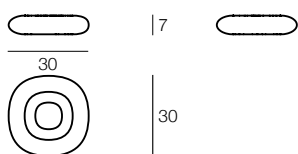

SRI00281

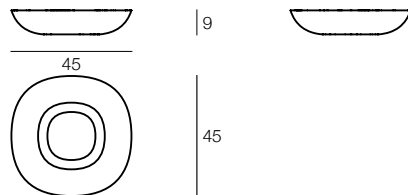

SRI00282

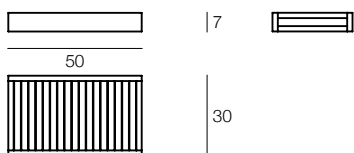

# CAMILLA LAPUCCI LAPO BIANCHI LUCI



Camilla Lapucci e Lapo Bianchi Luci, l'uno architetto e l'altro designer, lavorano insieme dal 2002 esplorando differenti territori che spaziano dall'architettura all'interior design, dalla direzione artistica al graphic design.

Le differenti singole precedenti esperienze in prestigiosi studi di Architettura di Firenze sono confluite in un percorso comune che ha poi permesso di iniziare un'intensa collaborazione con il mondo dell'interior design e del wellness, occupandosi di progetti di architettura e di interni a livello nazionale ed internazionale, coprendo diversi settori.

Ogni progetto è concepito attraverso un'accurata scelta di materiali e di superfici, di volumi, di pieni e di vuoti in reciproca relazione.

Nel settore delle SPA hanno ricevuto diversi riconoscimenti e premi tra cui il premio del Gran Prix Casalgrande e la menzione speciale al Wellness Design Awards.

Camilla Lapucci and Lapo Bianchi Luci, the first architect and the other designer, have been working together since 2002 to explore different areas, ranging from architecture to interior design, from art direction to graphic design.

The different individual previous experience in prestigious Architecture firms in Florence have merged into a common path that has allowed them to begin an intense collaboration with the world of interior design and wellness dealing with architectural and interior design projects at national and international levels.

Each project is conceived through a careful choice of materials and surfaces, volumes, solids and voids in a mutual relationship.

Concerning the SPA projects, they have received several awards and prizes, including the 1st prize in the Grand Prix Casalgrande in 2007 and a special mention at the Wellness Design Awards 2008.



# FINITURE

Tutti i manufatti lignei vengono prodotti con legno certificato e sottoposto a rigorosi controlli sia interni che da parte delle autorità competenti, lungo tutto il processo produttivo dalla piantagione alla consegna, secondo la rigida normativa europea FLEGT. Il legno utilizzato è legno di Teak della migliore qualità, disponibile nelle finiture 'Fine Sanded', ossia levigatura fine, 'Oil & Wax' eseguita con olio e cera, 'Java Brown' caratterizzata dalla pigmentazione scura color testa di moro, 'White Wash' e 'White Sand' dall'effetto decapato.

Per gli articoli RMIX041A e SRI00236 viene usato legno massiccio tropicale di Suar. Proposto con levigatura grezza e finitura ad olio.

L'articolo RMIX0499 è in legno di qualità miste.

Per gli articoli RMIX0872-0873-0874, viene utilizzato legno di Palma.

# FINISHING

All the wooden manufactured products are made of certified wood accurately controlled both by our staff and by the competent authorities during the entire production, from plantation to delivery, in compliance with the FLEGT strict European regulations

Wooden collections are made with the best quality teak wood available in different finishes: 'Fine Sanded', 'Oil & Wax', 'Java Brown' characterized by dark brown pigmentation, 'White Wash' and 'White Sand' with pickled effect.

Items with code RMIX041A and SRI00236 are made of Suar tropical hardwood with raw sanding and oil finish.

Item code RMIX0499 is made of mix wood.

Items RMIX0872-0873-0874 are made of Palm wood.



## FINITURE

L'acciaio inossidabile è una lega ferrosa che, grazie al contenuto di nichel e cromo, è molto resistente alla corrosione. L'alluminio viene utilizzato per creare le strutture interne dei mobili in rattan: preventivamente trattato e verniciato per una migliore protezione agli agenti atmosferici, viene successivamente utilizzato come supporto per l'intreccio della fibra sintetica. Per l'uso esposto vengono utilizzati tubolari di alluminio vergine oppure acciaio dolce sottoposti a bagni di pulitura e verniciati a polvere.

Per gli intrecciati sono impiegate fibre sintetiche a base polietilenica che hanno qualità uniche di resistenza ai raggi UV, di riciclabilità e di resistenza agli sbalzi di temperatura. Inoltre non necessitano di manutenzione e sono insensibili a funghi e parassiti.

Agli articoli in fibra naturale viene applicata una finitura trasparente protettiva. E' comunque sconsigliato l'uso all'esterno non coperto.

I piani in vetro hanno differenti bordature a seconda del modello e sono disponibili trasparenti, satinati, o fumè.

Il Batyline® è un tessuto che combina l'eleganza delle fibre naturali con la performance del tessile industriale.

Gli imbottiti standard sono in poliuretano a densità differenziata, disponibili su richiesta imbottiture drenanti o a cella piena. I tessuti standard a rivestimento della cuscineria sono in acrilico colore ecrù.

Su richiesta possono essere usati tessuti colorati Sunbrella® o di altro tipo a scelta del Cliente.

I tessuti Indonesiani Batik realizzati a mano usati per la collezione Cinéma d'été qui illustrata non sono da esterno. Sono disponibili a richiesta come copertura aggiuntiva alla federa standard in acrilico colore ecrù da esterno.

## FINISHING

The stainless steel is a ferrous alloy that, thanks to nickel and chromium, is highly corrosion-resistant. The stainless steel is a ferrous alloy that, thanks to nickel and chromium, is highly corrosion-resistant. Aluminium is used for the internal frames of the rattan furniture. It is previously treated and painted to better resist to weather conditions and then used to bear the synthetic fiber weave. Cleansed and powder coated tubular virgin aluminium or steel structures are employed for an exposed use.

The polyethylenic based synthetic fibers used for the woven collections have unique UV ray resistant qualities, can be recycled and boast a good resistance to changes in temperature. Moreover they do not need any maintenance and are insensitive to fungus and parasites.

Natural fibers items are protected by a transparent, semi-glossy finishing. It is anyway suggested not using it in an uncovered outdoor space.

The glass tops have different edges according to the model and are available in transparent, satin or smoke-grey version.

The technical fabric Batyline® combines the elegance of the natural fibers to the performance of the industrial fabric.

The standard upholstered are made of low/high density polyurethane foam or flow-through foam on customer's request.

On customer request can be used coloured Sunbrella® fabrics or other brands.

The traditional hand-made Indonesian Batik fabrics, used in the Cinéma d'été collection, shown in these pictures, are not suitable for an outdoor purpose. They are available on request as additional cover to the standard outdoor ecrù acrylic cover.

# MAINTENANCE

Il legno è un materiale 'vivo' che, in relazione al luogo in cui viene posizionato, può richiedere una particolare manutenzione. Con l'applicazione dell'olio e della cera, il Teak risulterà perfettamente protetto e ravvivato nel colore. L'olio per Teak può essere usato su legno grezzo come unico e completo agente protettivo, oppure su legno già trattato, purchè preventivamente pulito, come prodotto per la manutenzione. La cera fornisce uno strato protettivo ulteriore, pressoché invisibile, che riduce la penetrazione di macchie di oli e liquidi sulla superficie del legno. Si tratta di una cera in pasta di colorazione neutra, costituita da una miscela di elementi naturali selezionati tra cui cera d'api, cera carnauba ed essenza di trementina. I kit di manutenzione de Il Giardino di Legno sono ideali per lucidare e proteggere i mobili e gli oggetti in legno di Teak.

Wood is a "living" material which, depending on where it is placed, can require a particular maintenance. The Teak wood will result perfectly protected and brightened up the colour applying oil and wax. The oil for teakwood can be used on raw wood as single and complete protective agent or on already treated wood, provided that it has been cleaned before, as maintenance product. The wax provides a further protective layer, almost invisible, avoiding the food, oil and liquid stains to seep through the wood surface. It consists of a colourless wax paste, made of a mix of selected natural elements among which beeswax, carnauba wax and turpentine gum. The maintenance kits by Il Giardino di Legno are suitable to polish and protect teakwood furniture and objects.

MAIN2001



MAIN2002



MAIN2003



MAIN2004



MAIN2005







## COLLECTIONS

BOXER: ..... p 46

CINÉMA D'ÉTÉ: ..... p 50

CODE: ..... p 56

RADICE: ..... p 64

REMIX: ..... p 68

DECOR: ..... p 78

## MORE

DESIGNERS: ..... p 90

FINISHING: ..... p 92

MAINTENANCE: ..... p 94



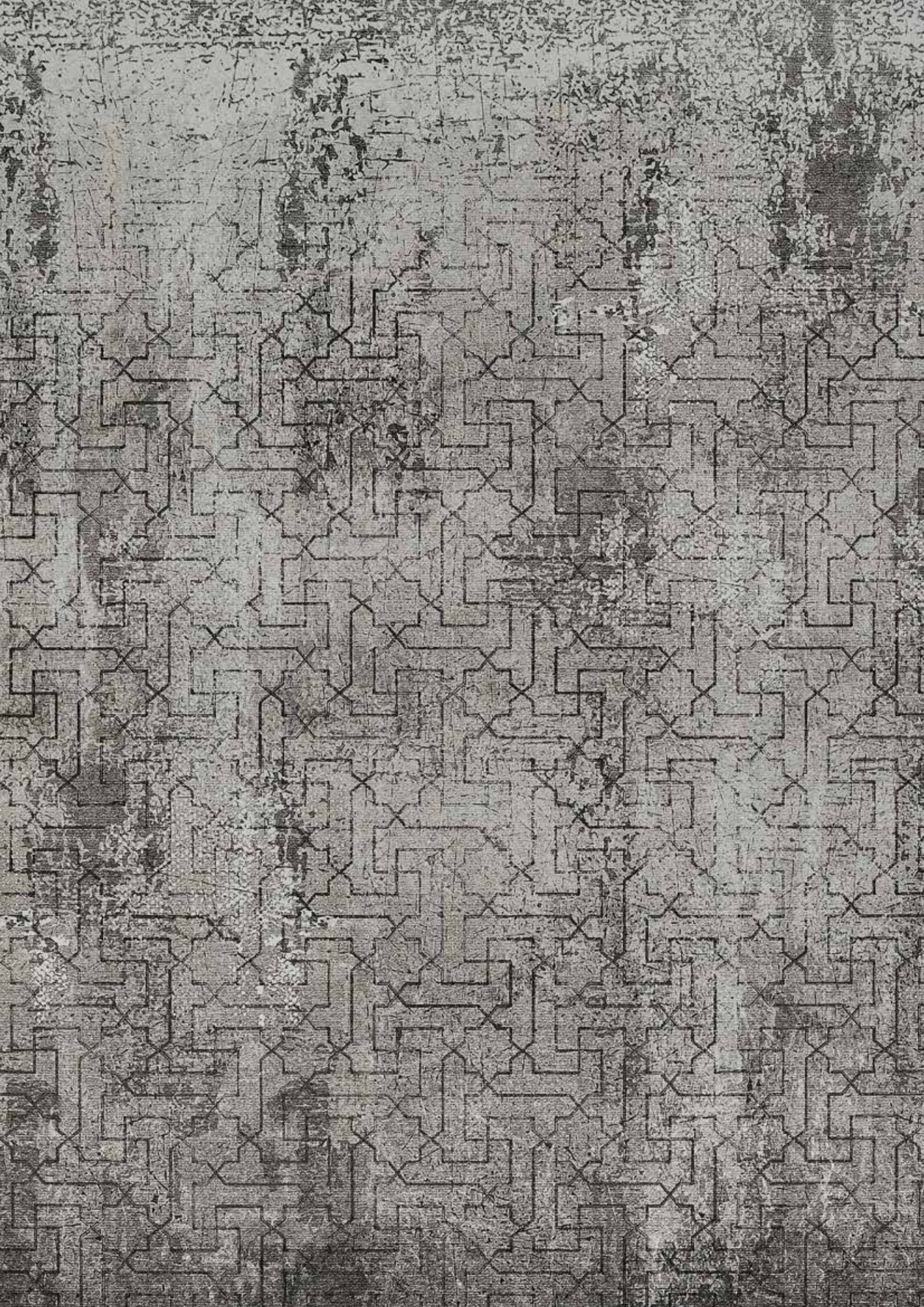



## *Il giardino di legno*

Il Giardino di Legno  
C.so Matteotti, 2 - Torino - Italia  
Tel +39.011.45.46.863  
Tel +39.011.19.50.24.29 Fax +39.011.19.50.24.30  
info@ilgiardinodilegno.it www.ilgiardinodilegno.it



SILAT srl - All rights reserved

Il Giardino di Legno - Viaggio Tropicale  
Collezione Boxer, Cinéma d'été, Code, Radice, Remix, Decor

Styling: Studio Salaris e Nazarena Manenti

Foto: Matteo Imbriani

L'azienda si riserva la facoltà di modificare, in qualunque momento e senza preavviso, le caratteristiche tecniche ed estetiche degli elementi illustrati nel presente catalogo.

*The factory reserves the right to change, at any time and without prior warning, the technical or esthetic specifications of any product illustrated in this catalogue.*



Il Giardino di Legno  
C.so Matteotti, 2 - Torino - Italia  
Tel +39.011.45.46.863  
Tel +39.011.19.50.24.29 Fax +39.011.19.50.24.30  
info@ilgiardinodilegno.it www.ilgiardinodilegno.it