

Ca' Venier

GIORNO - DAY



Cantiero



Ca' Venier

Collezione Esclusiva di Arredamento

Exclusive Furniture Collection

Cantiero
Stile Italiano

Cantiero
Stile Italiano

Ca' Venier:
una sintesi di emozioni e rigore.
La purezza del legno vive attraverso
la luce che ne scolpisce la superficie.

*Ca' Venier:
a synthesis of emotion and discipline.
The beauty of solid wood comes
alive through light which reveals
the richness and depth of the finish.*

CV01/D Credenza 2 ante e 2 cassetti
Sideboard 2 doors and 2 drawers
L.223 H.120 P./D.55





Decorazioni ad intarsio eseguite a mano secondo l'antica tecnica dei maestri intarsiatori italiani con spessore di 5 mm. Eleganza e grafie nel rispetto di un secolare valore.

Handmade wood inlay decoration 5mm thick, artfully executed in accordance with the time-honored techniques of master Italian cabinet-makers. Signature design elegance reflecting century-old values.

CV02/D Credenza 2 ante e 2 cassetti
Sideboard 2 doors and 2 drawers
L.192 H.101 P./D.55



Cantiero

Stile Italiano

Tutti i mobili contengono iconografie e decori originali gelosamente custoditi negli archivi Cantiero e riprodotti da sapienti mani di scultori artigiani.

All the furniture shares designs and original decorative elements jealously guarded in the Cantiero Archives and reproduced by the skillful hands of artisan sculptors.

CV07/D Credenza 2 ante e 3 cassetti
Sideboard 2 doors and 3 drawers
L.223 H.120 P./D.55





Oltre ad una numerosa gamma di basi, pensili, vetrine e mensole, la collezione prevede diverse tipologie di ante decorate ad intarsio.

Besides the numerous range of base units, hanging cupboards, glass-front cabinets, counters and shelves, the collection includes a varied selection of doors decorated with inlay.





Comp. CV1010 - L.410 H.208,2 P./D.29/45



Comp. CV1009 - L.300 H.208,2 P./D.29/45



Comp. CV1001 - L.420 H.208,2 P/D.29/45







Comp. CV1006 - L.268 H.208,2 P./D.29/45



Comp. CV1004 - L.324 H.172 P/D.45





CV09/A Tavolo rettangolare allungabile
Rectangular Table with extensions
L.185/285 H.78 P./D.90

CV34/P Sedia - Chair



CV04/A Argenteria 2 porte - Silver cabinet 2 doors
L.188 H.216 P./D.50
CV08 Tavolo quadrato allungabile - Square table
with extensions - L.100/200 H.78 P./D.100
CV34/P Sedia - Chair



CV01/D Credenza 2 ante 2 cassetti - Sideboard 2 doors
and 2 drawers - L.223 H.120 P./D.55





Comp. CV1008 - L.296 H.209 P./D.29/45

Cantiero

Stile Italiano

Alcune parti della collezione Ca' Venier sono proposte anche in versione con finitura naturale eseguita ad arte in un connubio tra antiche tecniche di ebanisteria e rispetto dei contenuti naturali del legno massello.

Parts of the Ca' Venier collection are also offered with a natural finish achieved through the marriage of time-honored cabinet making techniques and respect for the innate qualities of solid wood.





La parete Ca' Venier offre infinite possibilità compositive: sia classiche che contemporanee con finitura tradizionale o naturale.

The Ca' Venier wall units offer infinite combinations: from the more classical to the contemporary with the choice of traditional or natural finishing.

Comp. CV1008/BIO
L.296 H.209 P./D.29/45



Comp. CV1005 - L.340 H.208,2 P./D.29/43





Ca' Venier

Moduli per la parete componibile - Wall Units

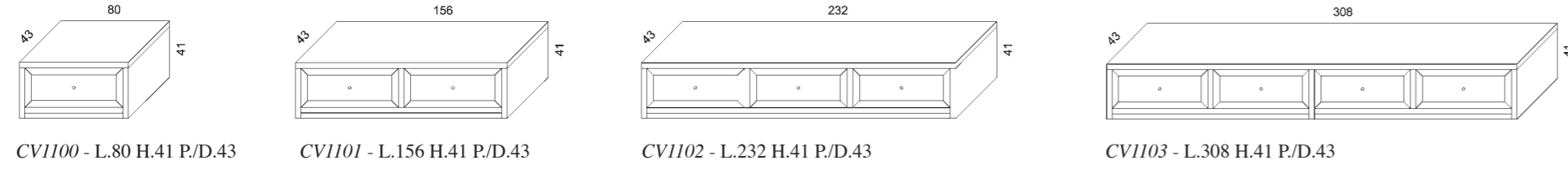

CV1100 - L.80 H.41 P/D.43 CV1101 - L.156 H.41 P/D.43 CV1102 - L.232 H.41 P/D.43 CV1103 - L.308 H.41 P/D.43

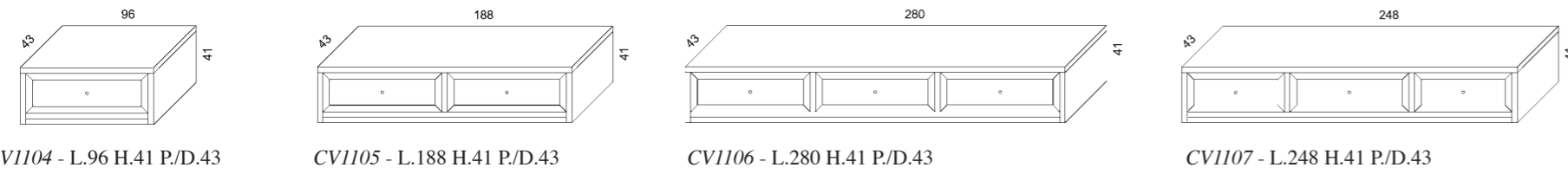

CV1104 - L.96 H.41 P/D.43 CV1105 - L.188 H.41 P/D.43 CV1106 - L.280 H.41 P/D.43 CV1107 - L.248 H.41 P/D.43

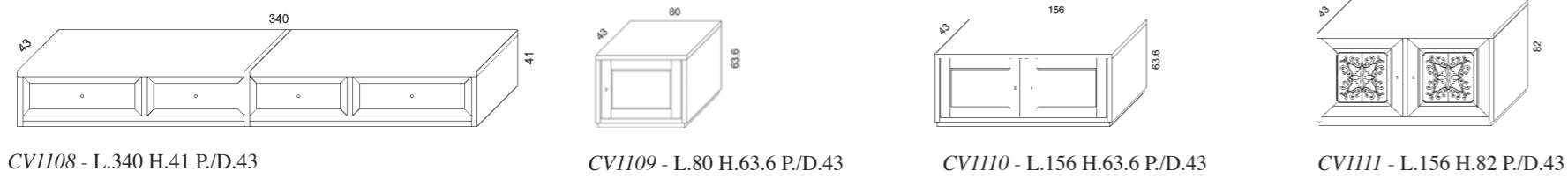

CV1108 - L.340 H.41 P/D.43 CV1109 - L.80 H.63.6 P/D.43 CV1110 - L.156 H.63.6 P/D.43 CV1111 - L.156 H.82 P/D.43

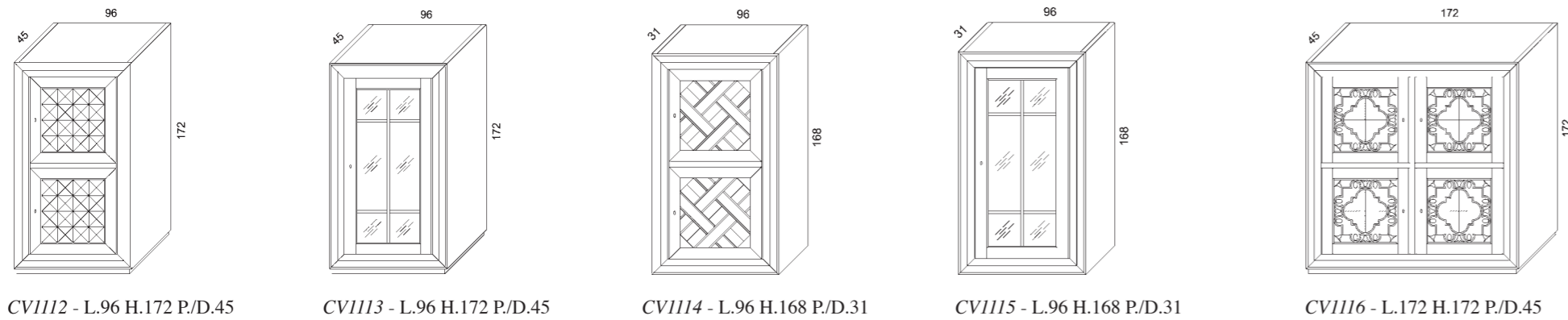

CV1112 - L.96 H.172 P/D.45 CV1113 - L.96 H.172 P/D.45 CV1114 - L.96 H.168 P/D.31 CV1115 - L.96 H.168 P/D.31 CV1116 - L.172 H.172 P/D.45

Ca' Venier

Moduli per la parete componibile - Wall Units

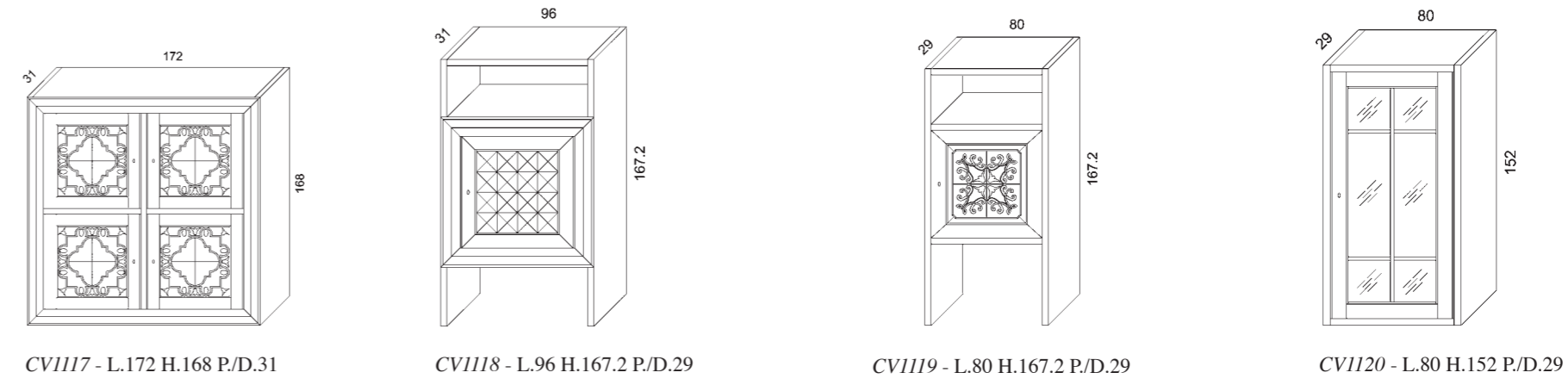

CV1117 - L.172 H.168 P/D.31 CV1118 - L.96 H.167.2 P/D.29 CV1119 - L.80 H.167.2 P/D.29 CV1120 - L.80 H.152 P/D.29

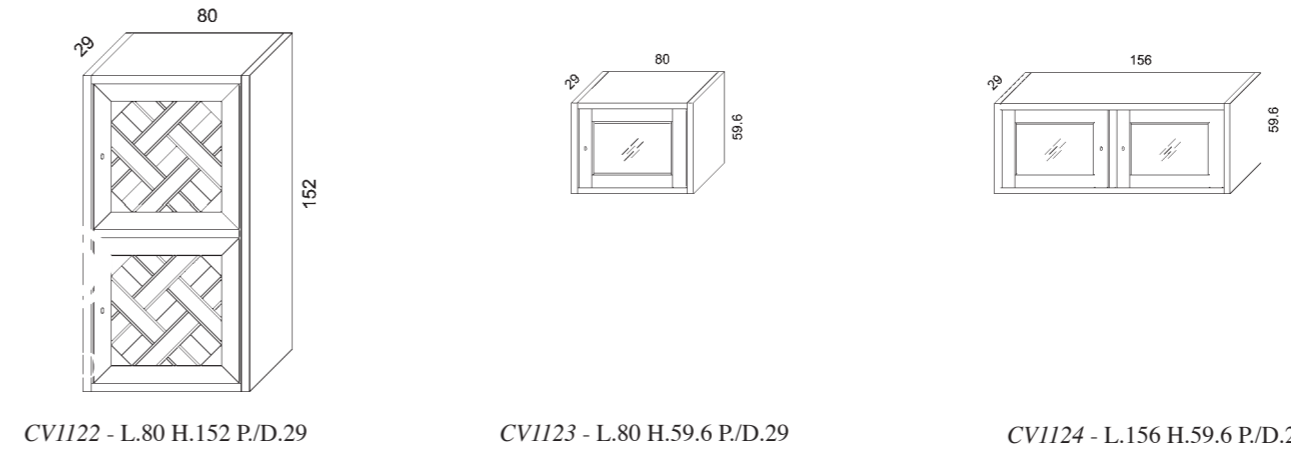

CV1122 - L.80 H.152 P/D.29 CV1123 - L.80 H.59.6 P/D.29 CV1124 - L.156 H.59.6 P/D.29

Ca' Venier

Porte - Doors



Anta/Door A9 - Provenza



Anta/Door A10 - Corner



Anta/Door A7 - Diamante



Anta/Door A3 - Giglio



Anta/Door A8 - Parquet



Un esempio di finitura naturale.
Disponibile su tutte le ante.

An example of the natural finish.
Available for any of the cabinet doors.

Ca' Venier

Composizioni - Compositions



Comp. CV1010 - L.410 H.208,2 P./D.29/45 - Pag. 12-13



Comp. CV1009 - L.300 H.208,2 P./D.29/45 - Pag. 14-15



Comp. CV1001 - L.420 H.208,2 P./D.29/45 - Pag. 16-17



Comp. CV1011 - L.348 H.208,2 P./D.29/45 - Pag. 18-19



Comp. CV1003 - L.359 H.208,2 P./D.29/45 - Pag. 20-21



Comp. CV1006 - L.268 H.208,2 P./D.29/45 - Pag. 22-23

Ca' Venier

Nuovi elementi - New items



Comp. CV1004 - L.324 H.172 P/D.45 - Pag. 24-25



Comp. CV1012 - L.344 H.208,2 P/D.29/45 - Pag. 26-27



Comp. CV1007 - L.404 H.193 P/D.29/45 - Pag. 32-33



Comp. CV1008 - L.296 H.209 P/D.29/45 - Pag. 34-35



Comp. CV1008/BIO - L.296 H.209 P/D.29/45 - Pag. 38-39



Comp. CV1005 - L.340 H.208,2 P/D.29/43 - Pag. 40-41



Comp. CV1014 - L.388 H.208,2 P/D.29/43
Pag. 42-43



CV01/D Credenza 2 ante 2 cassetti
Sideboard 2 doors and 2 drawers
L.223 H.120 P/D.55 - Pag. 5



CV02/D Credenza 2 ante 2 cassetti
Sideboard 2 doors and 2 drawers
L.192 H.101 P/D.55 - Pag. 7



CV07/D Credenza 2 ante e 3 cassetti
Sideboard 2 doors and 3 drawers
L.223 H.120 P/D.55 - Pag. 9



CV09/A Tavolo rettangolare allungabile
Rectangular Table with extensions
L.185/285 H.78 P/D.90 - Pag. 28-29

CV34/P Sedia - Chair

Ca' Venier

Modello depositato
Patented Model

Progetto Arbet Design

Scenografia, direzione artistica e grafica/Set design and Artwork:

Angelo Pontecorboli, Firenze

Stylist: Lilli Bacci, Firenze

Fotografia/Photography: Enrico Conti, Milano

Assistente alla fotografia/Photo Assistant: Chiara Capuzzi

Impianti/Photo-lithography: Raf, Firenze

Stampa/Printer: Arti Grafiche Padovane, Padova

Oggettistica/Props:

Baga

Egizia

Ego

Fantechi

Ivat

La Murrina

Leonardo

Marioni

Murano.com



L'originalità e l'autenticità
dei mobili fabbricati da Cantiero
sono autenticati dal marchio a fuoco.

The originality and authenticity
of the furniture produced
by Cantiero are guaranteed
by the fire brand.

Cantiero

Ebanisti dal 1949
Cabinet Makers since 1949

www.cantiero.it

Via Cadalora, 22 - 37050 Ca' degli Oppi (VR) - Italy
Tel.+39 045 7130700 - fax + 39 045 7130611
Email: cantimob@libero.it - www.cantiero.it