

SPECIES UNICA



BORN IN VENICE

2020

TECHNICAL BROCHURE

US

SPECIES UNICA



BORN IN VENICE

#### DISCLAIMER - GENERAL NOTES

Due to conversion from metric sizes and measurements, the US values provided are approximate.

The information provided by WoodN Industries in this document are solely indicative, they are based on the present state of knowledge and must be considered only as a description of our products and their possible application. Such information must not be interpreted as a guarantee of specific features, performances or warranties of the product. Material's colors and finishes represented in this document are the result of printing techniques so they may slightly differ from the original colors. Original samples are available upon request and constitute only a general indication of the dimensions and the aesthetic appearance of Woodn™ profiles. WoodN Industries may change the information included in this document at any time and without further notice. WoodN Industries does not warrant the accuracy and completeness of the information in this document and furthermore their suitability for the purpose which it is consulted for by the other parties. WoodN's customers or third parties must ascertain they have the most recent version of this document, available at [www.woodn.com](http://www.woodn.com). It is advised that customers and third parties have a professional adviser to inform them about the suitability of the products for all desired applications and about applicable laws and regulations. WoodN Industries reserves the right to modify products and concerning features without prior notice. WoodN Industries is not liable for any damage arising from, or related to, the use of this document. Woodn™ material does not have structural characteristics and therefore WoodN Industries declines all responsibilities for improper use of the material. No sections of this publication can be reproduced, stored in database, or transmitted in any form or by any other mean without the explicit approval of WoodN Industries. For more information please contact WoodN Industries.

## INDEX

- Sunscreen - VERSATILIS pag. 5
- Decking - GREENDECK pag. 47
- Cladding/Ceiling - MODULATUS pag. 61
- Indoor cladding - ORNANS pag. 105
- Handling, cleaning and maintenance notes pag. 113
- Color's accelerated aging test pag. 117
- Colors and finishes pag. 120

# VERSATILIS/



sunscreen - louvers

---

pergolas - fences

WOODN VERSATILIS: VERTICAL BEAUTY

**LOUVERS:** VARIOUS PROPOSALS FOR COUNTLESS SOLUTIONS. IT IS A SUNSCREEN FOR POSITIVE ENERGY BUILDINGS, GUARANTEEING REDUCED CONSUMPTION AND LIVING COMFORT.

**ASSEMBLED WINDOWS AND SCREENS:**  
AS YOU LIKE, SEVERAL COMPOSITIONS AND DESIGNS.

**FENCES AND PERGOLAS:**  
A READY-MADE SOLUTION, EASY TO ASSEMBLE AND SAFE.

# GREENDECK/



outdoor decking

WOODN GREENDECK

AN ULTIMATE SOLUTION FOR OUTDOOR ENVIRONMENTS, IT LEAVES NO SPLINTERS.  
IT IS CERTIFIED SLIP-RESISTANT, DOES NOT REQUIRE WOOD MAINTENANCE, AND IT IS DIMENSIONALLY STABLE.

# MODULATUS/



outdoor cladding -

---

outdoor/indoor ceilings

WOODN MODULATUS: TOTAL LOOK

**CLADDING:** A SIDING FOR EXTERIORS, WHICH QUALIFIES THE BUILDING IN TERMS OF BEAUTY AND FUNCTIONALITY. WITH ITS CERTIFIED PROPERTIES, SUCH AS RESISTANCE TO FIRE AND WIND STRENGTH, IT ENSURES HIGH SAFETY STANDARDS.

**CEILING:** A COMPLETE SYSTEM, EASY TO INSTALL AND MODULAR, WHICH ALLOWS THE COMPLETION AND RENEWAL OF RESIDENTIAL AND COMMERCIAL ENVIRONMENTS.

# ORNANS/



indoor cladding mosaic

WOODN ORNANS

IT IS THE TWO-FACED TECHICAL COVERING CONCEIVED TO BEST MEET THE DEMANDS OF CONTEMPORARY ARCHITECTURE AND INTERIOR DESIGN. LIGHTNESS, THICKNESS AND EASY INSTALLATION MAKE THIS PRODUCT APPLICABLE ON ANY SURFACE.

# WOODN VERSATILIS



#### DISCLAIMER - GENERAL NOTES

Due to conversion from metric sizes and measurements, the US values provided are approximate.

The information provided by WoodN Industries in this document are solely indicative, they are based on the present state of knowledge and must be considered only as a description of our products and their possible application. Such information must not be interpreted as a guarantee of specific features, performances or warranties of the product. Material's colors and finishes represented in this document are the result of printing techniques so they may slightly differ from the original colors. Original samples are available upon request and constitute only a general indication of the dimensions and the aesthetic appearance of Woodn™ profiles. WoodN Industries may change the information included in this document at any time and without further notice. WoodN Industries does not warrant the accuracy and completeness of the information in this document and furthermore their suitability for the purpose which it is consulted for by the other parties. WoodN's customers or third parties must ascertain they have the most recent version of this document, available at [www.woodn.com](http://www.woodn.com). It is advised that customers and third parties have a professional adviser to inform them about the suitability of the products for all desired applications and about applicable laws and regulations. WoodN Industries reserves the right to modify products and concerning features without prior notice. WoodN Industries is not liable for any damage arising from, or related to, the use of this document. Woodn™ material does not have structural characteristics and therefore WoodN Industries declines all responsibilities for improper use of the material. No sections of this publication can be reproduced, stored in database, or transmitted in any form or by any other mean without the explicit approval of WoodN Industries. For more information please contact WoodN Industries.

# MATERIAL'S FEATURES

## Mechanical properties

Elasticity (bending)	UNI EN ISO 178	@73 °F @149 °F
Yield strenght (flexural)	UNI EN ISO 178	@73 °F @149 °F
Water absorbption and humidity	ASTM D1037	absorption 0,07%
Dynamic- Mechanical analysis of transition temperature	ASTM D4065/95	173.8 °F
Linear thermal expansion coefficient (from 14 °F to 158 °F)	TMA ASTM E 831/2006	longitudinal $46,9 \times 10^{-6} \text{ m}/(\text{m}^{\circ}\text{C})$ trasversal $48 \times 10^{-6} \text{ m}/(\text{m}^{\circ}\text{C})$
Tensile strenght and tensile strenght after accelerated weathering (exposure to xenon lights)	ASTM D638-10 (tensile test) ASTM G155-050	difference after 2 months of exposure ~5,21% difference after 3 months of exposure ~6,9% (meet the requirements to comply with Miami Dade and Florida Building Code 2014)

## Reaction to fire

Flammability	UL94 AS 3959-2009	V-0 Class BAL-29
Flame spread index Smoke developed index	ASTM E84	Class A
Ignition temperature	ASTM D1929	890 °F
Average critical radiant flux of floor	AS ISO 9239 ASTM E648	$\geq 11 \text{ kW}/\text{m}^2$ $> 1,03 \text{ W}/\text{cm}^2$ (class I as per NFPA 101)
Ignitability, flame propagation, heat release and smoke release	AS/NZS 1530.3:1999	Ignitability (0-20) = 8 Spread of Flame (0-10) = 0 Heat Evolved (0-10) = 0 Smoke Developed (0-10) = 7

## Chemical and biological features

Evaluation of the action of microorganisms (scale from 0 to 5)	EN ISO 846:97	Test result: 1
Heavy metal content (Pb, Ge, Cr, Hg)	GB18584-2001 GB18580-2001	< 0,5 ppm
Formaldehyde emission	EN 717-2:1994	0,1 mg HCHO/(m <sup>2</sup> h)













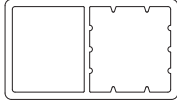

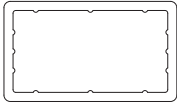
The values shown are indicative and not binding. Test reports available upon request.  
The natural aging of the material and temperature variations may cause deviations from the values indicated above.  
The product is protected by a warranty in line with legal requirements: for more information see the SPECS on [www.woodn.com](http://www.woodn.com)

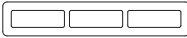
# PROFILES SECTION

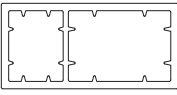

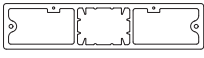

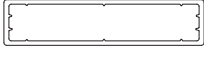

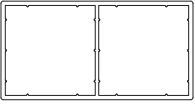



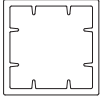

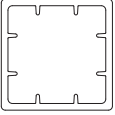
Woodn recommends to refer only to the values expressed in mm the US values are to be considered approximate).

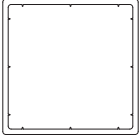
profile	cross-section	nominal dimensions [ft, in]	reinforcement external nominal dimensions [ft, in]	weight of the plank [lb/ft]
<b>LG3020</b> 		section 30 x 20 mm (≈ 1"3/16 x 13/16") standard length 1830 mm (≈ 6')	20 x 10 mm (≈ 13/16" x 7/16")	0.31
<b>JF4030-30x20</b> 		section 40 x 30 mm (≈ 1"5/8 x 1"3/16) standard length 1830 mm (≈ 6')	30 x 20 mm (≈ 1"3/16 x 13/16")	0.44
<b>JF5026-40x15</b> 		section 50 x 26 mm (≈ 2" x 1"1/16) standard length 1830 mm (≈ 6')	40 x 15 mm (≈ 1"5/8 x 5/8")	0.49
<b>JF6032</b> 		section 60 x 32 mm (≈ 2"3/8 x 1"5/16) standard length 1830 mm (≈ 6')	20 x 20 mm (≈ 13/16" x 13/16")	0.81
<b>JF7040-25x25</b> 		section 70 x 40 mm (≈ 2"13/16 x 1"5/8) standard length 1830 mm (≈ 6')	25 x 25 mm (≈ 1" x 1")	0.97
<b>JF7040-30x15</b> 		section 70 x 40 mm (≈ 2"13/16 x 1"5/8) standard length 1830 mm (≈ 6')	30 x 15 mm (≈ 1"3/16 x 5/8")	0.85
<b>JF7040-50x25</b> 		section 70 x 40 mm (≈ 2"13/16 x 1"5/8) standard length 1830 mm (≈ 6')	50 x 25 mm (≈ 2" x 1")	0.78

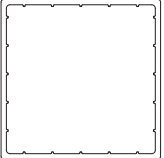



Woodn recommends to refer only to the values expressed in mm the US values are to be considered approximate).

profile	cross-section	nominal dimensions [ft, in]	reinforcement external nominal dimensions [ft, in]	weight of the plank [lb/ft]
<b>TZ9555-R</b> 		section 95 x 55 mm (≈ 3"3/4 x 2"3/16) standard length 1830 mm (≈ 6')	40 x 40 mm (≈ 1"5/8 x 1"5/8)	1.21
<b>TZ9555</b> 		section 95 x 55 mm (≈ 3"3/4 x 2"3/16) standard length 1830 mm (≈ 6')	80 x 40 mm (≈ 3"3/16 x 1"5/8)	1.37
<b>JF11020</b> 		section 110 x 20 mm (≈ 4"3/8 x 13/16") standard length 1830 mm (≈ 6')	L Profile 30 x 10 mm (≈ 1"3/16 x 7/16")	1.09
<b>JF12058-A</b> 		section 120 x 58 mm (≈ 4"3/4 x 2"5/16) standard length 1830 mm (≈ 6')	30 x 40 mm (≈ 1"3/16 x 1"5/8)	1.46
			60 x 40 mm (≈ 2"3/8 x 1"5/8)	
<b>JF18041</b> 		section 180 x 41 mm (≈ 7"1/8 x 1"5/8) standard length 1830 mm (≈ 6')	30 x 30 mm (≈ 1"3/16 x 1"3/16)	1.89
			40 x 20 mm (≈ 1"5/8 x 13/16")	
<b>JF18041-165x30</b> 		section 180 x 41 mm (≈ 7"1/8 x 1"5/8) standard length 1830 mm (≈ 6')	165 x 30 mm (≈ 6"1/2 x 1"3/16)	1.56
<b>JF222114</b> 		section 222 x 114 mm (≈ 8"3/4 x 4"1/2) standard length 1830 mm (≈ 6')	100 x 100 mm (≈ 3"15/16 x 3"15/16)	2.86

Woodn recommends to refer only to the values expressed in mm the US values are to be considered approximate).

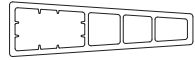
profile	cross-section	nominal dimensions [ft, in]	reinforcement external nominal dimensions [ft, in]	weight of the plank [lb/ft]
<b>TZ6060</b> 		section 60 x 60 mm (≈ 2"3/8 x 2"3/8) standard length 1830 mm (≈ 6')	40 x 40 mm (≈ 1"5/8 x 1"5/8)	0.81
<b>JF7070</b> 		section 70 x 70 mm (≈ 2"13/16 x 2"13/16) standard length 1830 mm (≈ 6')	50 x 50 mm (≈ 2" x 2")	1.03
<b>TZ113113</b> 		section 113 x 113 mm (≈ 4"1/2 x 4"1/2) standard length 1830 mm (≈ 6')	100 x 100 mm (≈ 3"15/16 x 3"15/16)	1.61
<b>TZ180180</b> 		section 180 x 180 mm (≈ 7"1/8 x 7"1/8) standard length 1830 mm (≈ 6')	163 x 163 mm (≈ 6"3/8 x 6"3/8)	3.79
<b>JF15238</b> 		section 152 x 38 mm (≈ 6" x 1"1/2) standard length 1830 mm (≈ 6')	25 x 25 mm (≈ 1" x 1")	1.24
<b>JF20058</b> 		section 200 x 58 mm (≈ 7"7/8 x 2"5/16) standard length 1830 mm (≈ 6')	40 x 40 mm (≈ 1"5/8 x 1"5/8)	2.07
<b>JF35068</b> 		section 350 x 68 mm (≈ 1' 1"3/4 x 2"11/16) standard length 1830 mm (≈ 6')	100 x 40 mm (≈ 3"15/16 x 1"5/8)	2.93

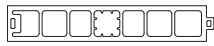
Woodn recommends to refer only to the values expressed in mm the US values are to be considered approximate).

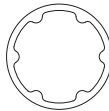
profile	cross-section	nominal dimensions [ft, in]	reinforcement external nominal dimensions [ft, in]	weight of the plank [lb/ft]
<b>JF15045-25</b> 		section 150 x 45 x 25 mm (≈ 5"15/16 x 1"13/16 x 1") standard length 1830 mm (≈ 6')	50 x 25 mm (≈ 2" x 1")	1.55
<b>DT20936</b> 		section 209 x 36 mm (≈ 8"1/4 x 1"7/16) standard length 1830 mm (≈ 6')	20 x 20 mm (≈ 13/16" x 13/16")	2.63
<b>C50R</b> 		section Ø 50 mm (≈ Ø 2") standard length 1830 mm (≈ 6')	Ø 38 mm (≈ Ø 1"1/2)	0.43

The external dimensions listed are nominal values. The weights of the planks indicated in the tables are indicative and not binding. The final weight depends on the gauge and size of the internal reinforcement. Length tolerances according UNI EN-ISO 22768: class UNI EN-ISO 22768-vL. Refer to Woodn Technical Department or on website [www.woodn.com](http://www.woodn.com) for cad blocks and manufacturing tolerances.

# GENERAL INSTALLATION INSTRUCTIONS

Key points to be followed before and during the installation process:

- Store the material on a flat surface providing for a stable support on the whole surface, in a dry, clean area, protected from frost and direct sun light.
- Before starting the installation, carefully check the material and notify immediately of any manufacturing issues. Complaints will not be accepted after installation.
- Before starting the installation, check project's drawings (or shop drawings if provided) and the correspondence of the received material against the packing list.
- Acclimate the material in stock to the temperature of the jobsite for at least 48 hours prior to installation.
- The installation temperature must be higher than 32 °F.
- Do not cover the product with sheets made with non-breathable material (nylon, polyethylene and similar materials). For this purpose it is advisable to use breathable material such as painter felt sheets.
- The accumulation of electrostatic charges is a natural phenomenon commonly found in plastic materials, and under exceptional environmental conditions this may also occur in Woodn™'s products.
- Profiles shall be handled with care in order to prevent damages. It is recommended to lift the profiles on the whole length during displacement and not make them slide on top of each other. Always use clean fabric gloves when handling profiles.
- Prevent the formation of dirt on and between profiles; in particular, make sure that mechanical processes carried out on other materials, near Woodn products, do not determine the accumulation of chips or dust of any kinds. During the installation/assembly phase do not apply any label or sticker; if already applied, please remove immediately after installation. Immediately remove major stains such as paint, concrete or tar residues.
- For cleaning and maintenance instructions refer to page 115. The WoodN warranty will be rendered null and void in the event of incorrect or improper handling, cleaning and maintenance.

## ASSEMBLY CENTRE-TO-CENTRE DISTANCE

The assembly centre-to-centre distance must be adequately sized to meet the loads specified in current regulations. The following pages show the maximum centre-to-centre application distance for each Versatilis profile, according to the visible side, the horizontal or vertical installation of the profiles and the type of metal reinforcement used. The values in the tables have been calculated considering a wind load of 30.73 pound/sqft.

The profiles must be mounted using mechanical systems that join the substructure to the metal reinforcement.

IN ORDER TO ALLOW A NORMAL EXPANSION, NO FIXING MUST BE DONE DIRECTLY ON THE WPC PROFILE.

## FIXED POINT AND FLOATING POINT

When applying the profiles and fixing them to the substructure, consider making a FIXED POINT, which blocks the profile in a precise position during expansion due to thermal variations.

In all the other fixing points, FLOATING POINTS must be created to let the profile expand freely. The floating points can be made by drilling suitably sized holes or slots depending on the distance between the fixed point and the floating points based on the calculation below:

$$\text{floating point hole diameter} = \text{floating point slot length} = 2 \times L \times 0.003 + \emptyset$$

where  $L$  = centre-to-centre distance between the fixed point and the floating point  
and  $\emptyset$  = diameter of the fixing screw

For example:

$$L = 6'6''3/4, \emptyset = 3/16''$$

$$\text{floating point hole diameter} = \text{floating point slot length} = 2 \times 6'6''3/4 \times 0.003 + 3/16'' = 11/16''$$

WARNING: it has to be noted that the failure to comply strictly with the criteria for the application of fixed points and floating points, causes the deformation of the materials and the misalignment of all the expansion joints.

## EXPANSION GAP BETWEEN ADJACENT PROFILES

WoodN, due to material's composition's features and extrusion technology, undergoes after the first exposure an initial dimensional shrinkage less than 0.4% of the profile length (max value established according to EN 479: 1995) and presents a linear contraction / dilatation due to temperature variations.

At the end of the profile, leave a gap according to the relative size in the table below:

Laying temperature	Expansion gap [in/ft]
< 68 °F	1/40" (2 mm/m)
> 68 °F	1/80" (1 mm/m)

To make sure that the expansion spaces will remain over time, we recommend strictly adhering to the FIXED POINT positioning diagram.

## LAYING PATTERN - PARALLEL

● = fixed point for expansion

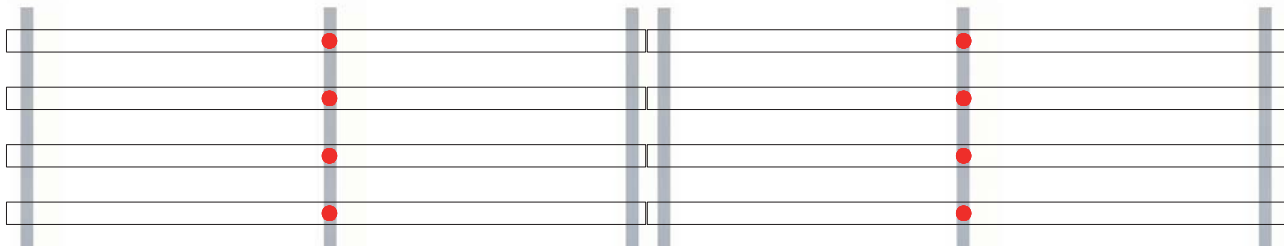

**WARNING:** if the application requires corners with planks cut at 45°, the fixed point must be in the corner.

**WARNING:** when mounting planks vertically, we recommend making the fixed point at the top end.

**WARNING CONCERNING INSTALLATION:** due to the peculiarities of the materials supplied, Woodn Industries expressly declines any liability related to its products if laying and installation are not carried out by specialized personnel, in accordance with the specific instructions, including those related to adhesives and accessories reported in the technical data sheets that come with the products.

**WARNING:** the structures shown in the drawings in the following pages only represent rough construction guidelines and all their components must be adequately sized by the customer in accordance with current regulations.

For any special needs, please contact our technical department: [ufficiotecnico@woodn.com](mailto:ufficiotecnico@woodn.com)

## INTERNAL REINFORCEMENT

For all applications, an internal metal (aluminum/steel) reinforcement **MUST** be inserted according to the features of each Woodn profile as described in the technical book.

The metal reinforcement profile must be 1"5/8 (40 mm) shorter than the WPC profile. When centered in the WPC profile, there must be 13/16" (20 mm) at each end. In the specific case of profiles which have the WoodN closing cap, the reinforcement profile must be 3"9/16 (90 mm) shorter, leaving 1"3/4 (45 mm) at the ends of the WPC profile.

**WARNING:** the lack of using the metal reinforcement inside the louver profiles causes the deformation of the material.

# LG3020

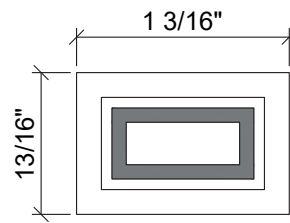

Woodn recommends to refer only to the values expressed in mm - the US values are to be considered approximate).

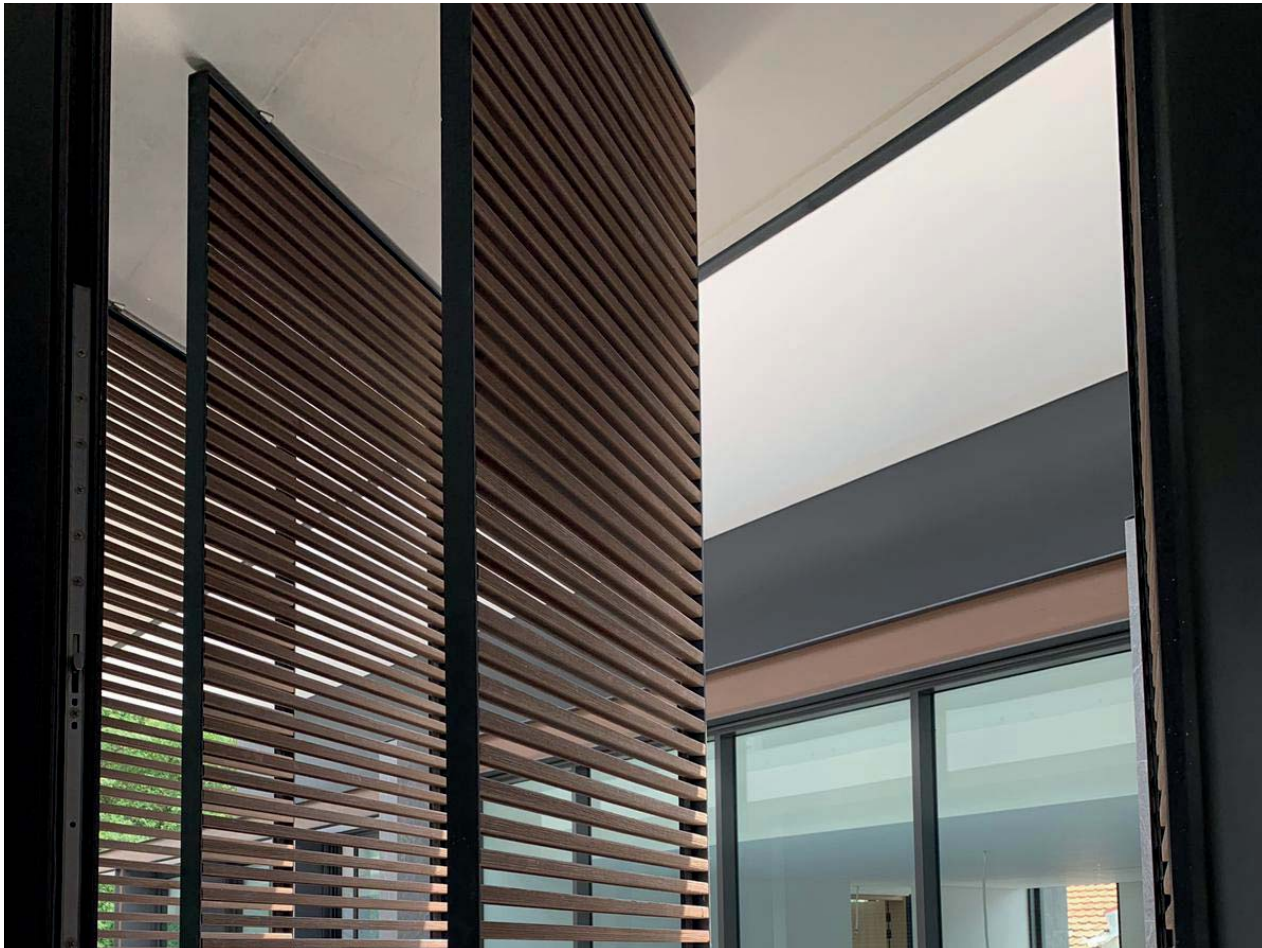

profile code	reinforcement dimensions [ft, in]	side [ft, in]	maximum horizontal span [inch]		maximum vertical span [inch]	
			aluminum	steel	aluminum	steel
<b>LG3020</b>	20 x 10 x 2 mm (≈ 13/16" x 7/16" x 5/64")	≈ 1" 3/16	≈ 47"	≈ 63"	≈ 59"	≈ 75"
		≈ 13/16"	≈ 39"	≈ 47"		

Maximum spans calculated considering:

- maximum permanent deformation due to own weight 1/8"
- maximum non-permanent deformation 1" 3/16 considering a standard wind load of 30.73 pound/ft<sup>2</sup>

# JF4030

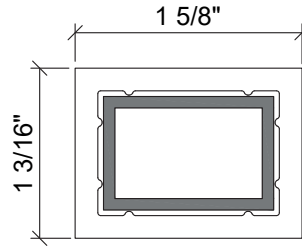

Woodn recommends to refer only to the values expressed in mm - the US values are to be considered approximate).



profile code	reinforcement dimensions [ft, in]	side [ft, in]	maximum horizontal span [inch]		maximum vertical span [inch]	
			aluminum	steel	aluminum	steel
<b>JF4030-30x20</b>	30 x 20 x 2 mm ( $\approx 1\frac{3}{16} \times 3\frac{1}{16} \times 5/64$ )	$\approx 1\frac{5}{8}$	$\approx 71''$	$\approx 86''$	$\approx 86''$	$\approx 114''$
		$\approx 1\frac{3}{16}$	$\approx 63''$	$\approx 75''$		

Maximum spans calculated considering:

- maximum permanent deformation due to own weight 1/8"
- maximum non-permanent deformation 1" 3/16 considering a standard wind load of 30.73 pound/ft<sup>2</sup>

# JF5026

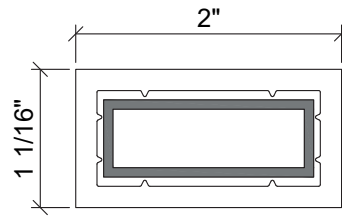

Woodn recommends to refer only to the values expressed in mm - the US values are to be considered approximate).

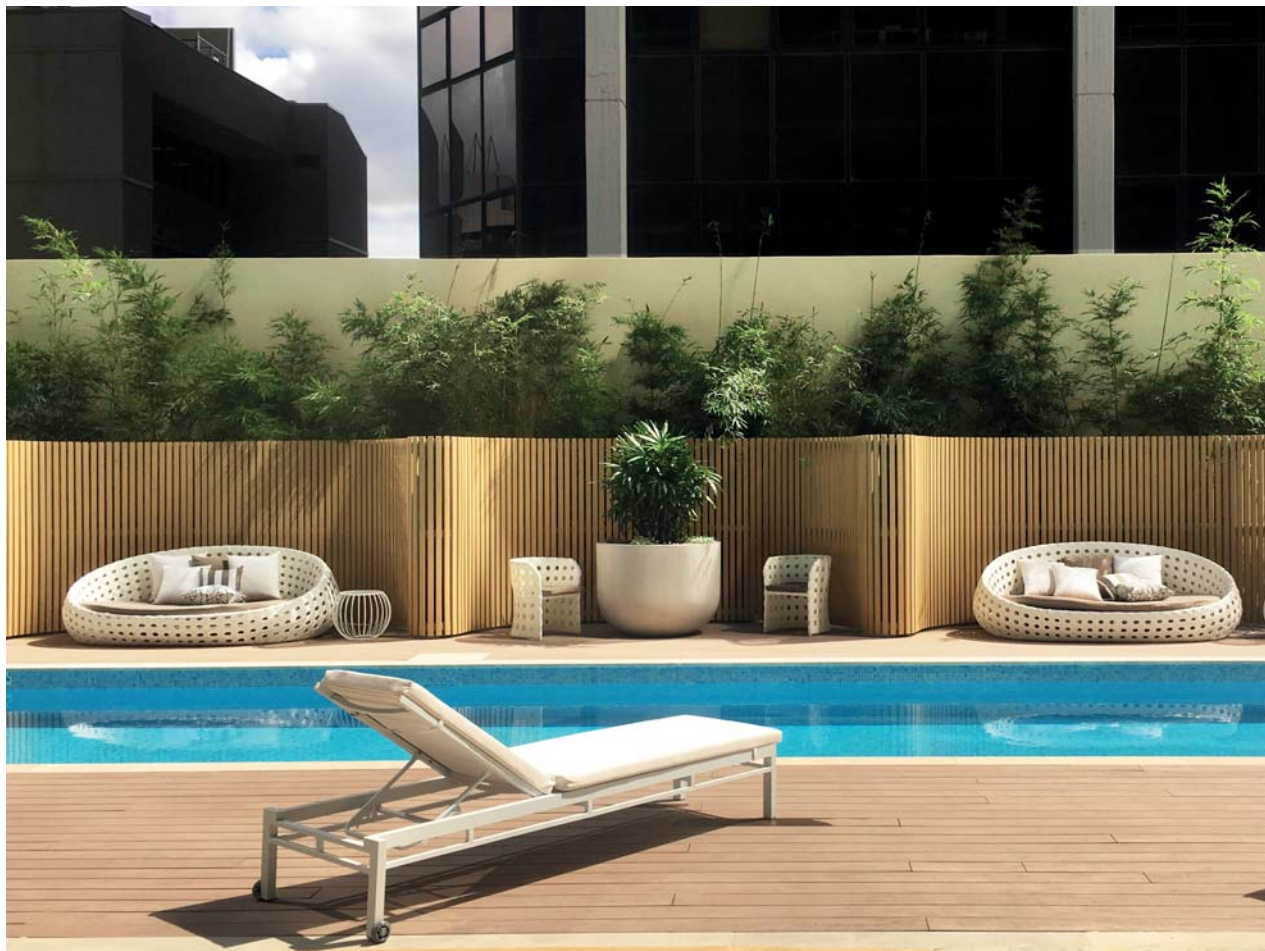

profile code	reinforcement dimensions [ft, in]	side [ft, in]	maximum horizontal span [inch]		maximum vertical span [inch]	
			aluminum	steel	aluminum	steel
<b>JF5026-40x15</b>	40 x 15 x 2 mm ( $\approx 1\frac{5}{8}$ x $5/8$ x $5/64$ )	$\approx 2$ "	$\approx 67$ "	$\approx 94$ "	$\approx 75$ "	$\approx 98$ "
		$\approx 1\frac{1}{16}$	$\approx 55$ "	$\approx 67$ "		

Maximum spans calculated considering:

- maximum permanent deformation due to own weight 1/8"
- maximum non-permanent deformation 1" 3/16 considering a standard wind load of 30.73 pound/ft<sup>2</sup>

# JF6032

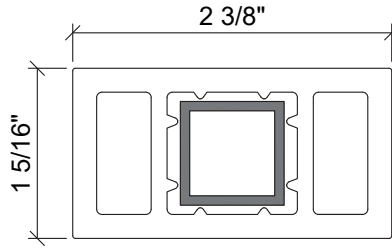

Woodn recommends to refer only to the values expressed in mm - the US values are to be considered approximate).



profile code	reinforcement dimensions [ft, in]	side [ft, in]	maximum horizontal span [inch]		maximum vertical span [inch]	
			aluminum	steel	aluminum	steel
<b>JF6032</b>	20 x 20 x 2 mm (≈ 13/16" x 13/16" x 5/64")	≈ 2"3/8	≈ 63"	≈ 71"	≈ 75"	≈ 94"
		≈ 1"5/16	≈ 55"	≈ 67"		

Maximum spans calculated considering:

- maximum permanent deformation due to own weight 1/8"
- maximum non-permanent deformation 1" 3/16 considering a standard wind load of 30.73 pound/ft<sup>2</sup>

# JF7040

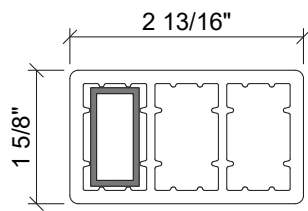

**JF7040-30x15**

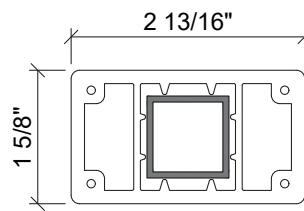

**JF7040-25x25**

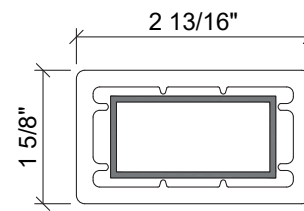

**JF7040-50x25**

Woodn recommends to refer only to the values expressed in mm - the US values are to be considered approximate).

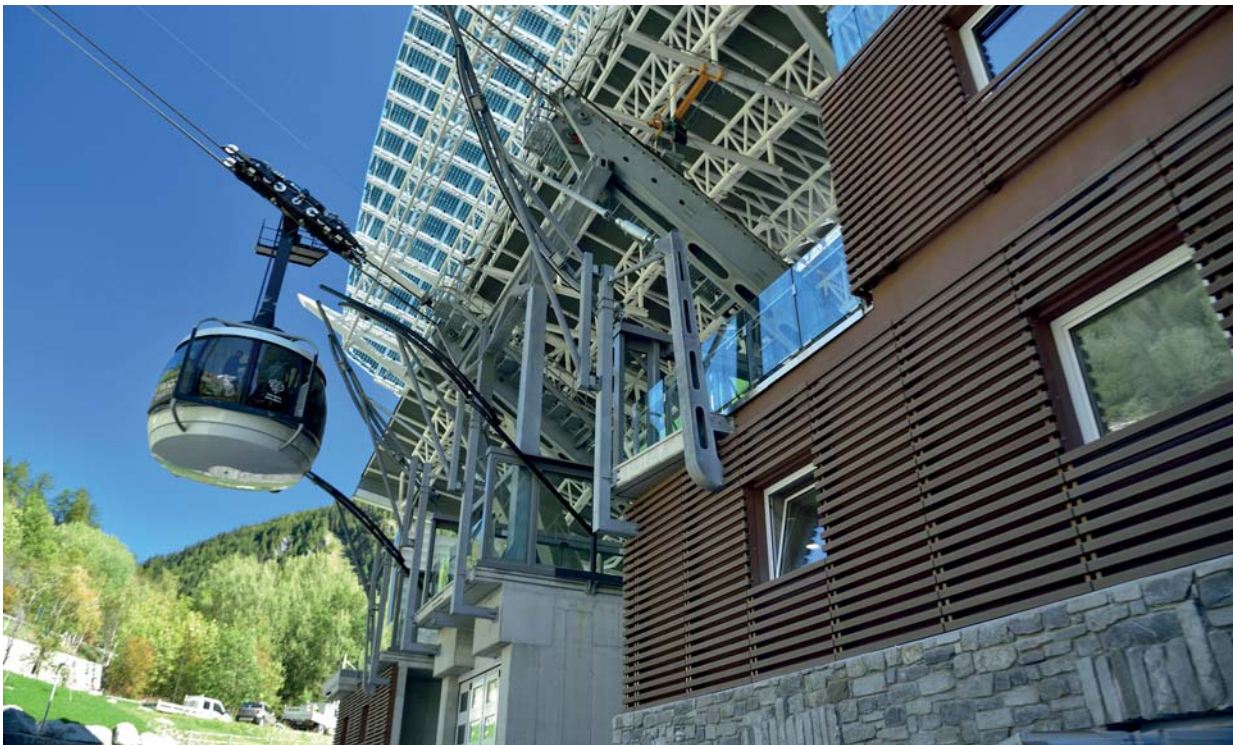

profile code	reinforcement dimensions [ft, in]	side [ft, in]	maximum horizontal span [inch]		maximum vertical span [inch]	
			aluminum	steel	aluminum	steel
<b>JF7040-30x15</b>	30 x 15 x 2 mm (≈ 1" 3/16 x 5/8" x 5/64")	≈ 2" 13/16	≈ 59"	≈ 67"	≈ 82"	≈ 102"
		≈ 1" 5/8	≈ 67"	≈ 79"		
<b>JF7040-25x25</b>	25 x 25 x 2 mm (≈ 1" x 1" x 5/64")	≈ 2" 13/16	≈ 71"	≈ 82"	≈ 86"	≈ 114"
		≈ 1" 5/8	≈ 67"	≈ 79"		
<b>JF7040-50x25</b>	50 x 25 x 2 mm (≈ 2" x 1" x 5/64")	≈ 2" 13/16	≈ 94"	≈ 118"	≈ 102"	≈ 130"
		≈ 1" 5/8	≈ 75"	≈ 90"		

Maximum spans calculated considering:

- maximum permanent deformation due to own weight 1/8"
- maximum non-permanent deformation 1" 3/16 considering a standard wind load of 30.73 pound/ft<sup>2</sup>

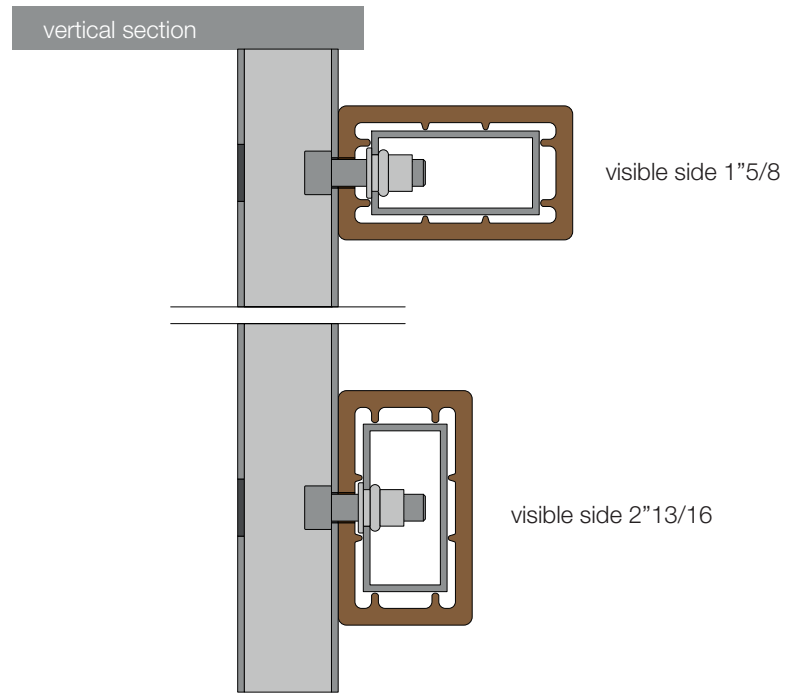
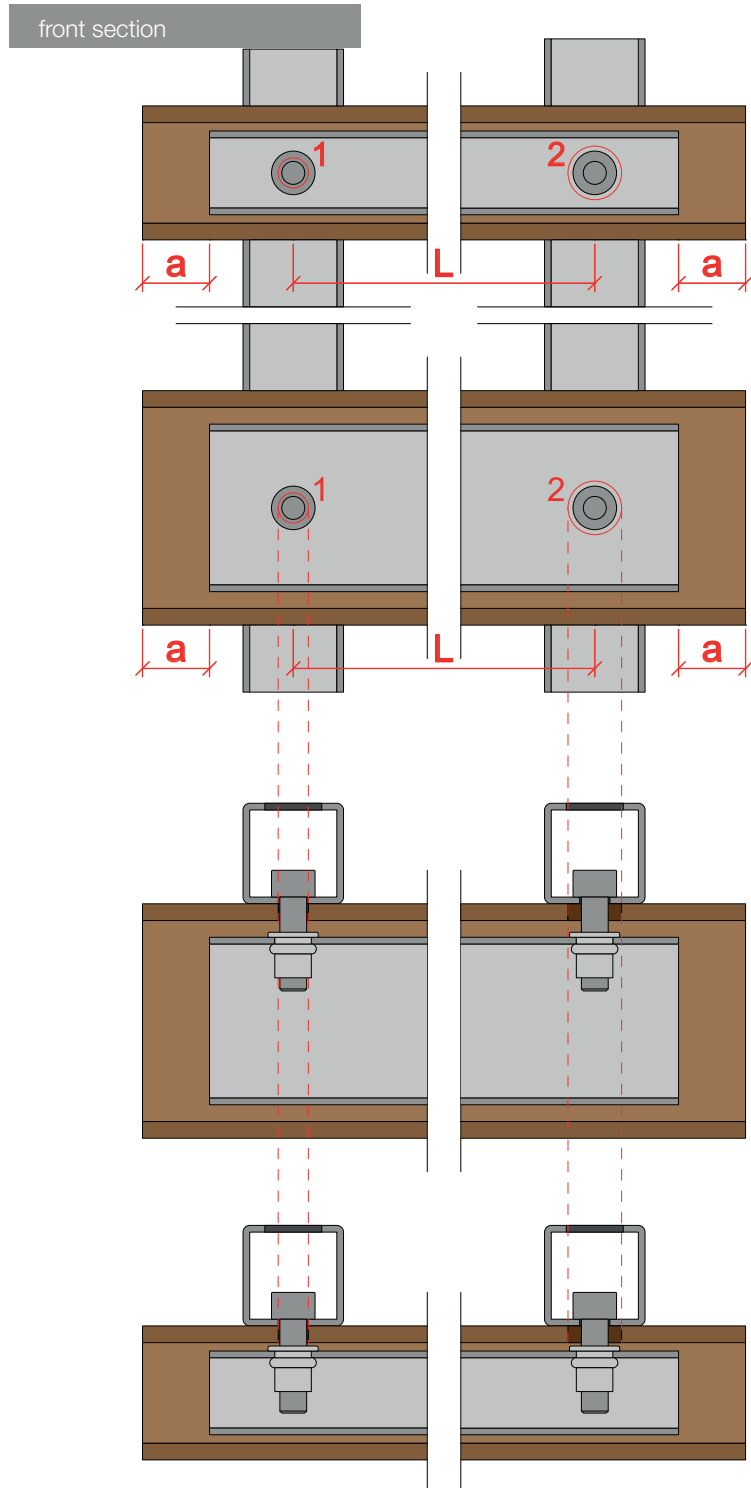
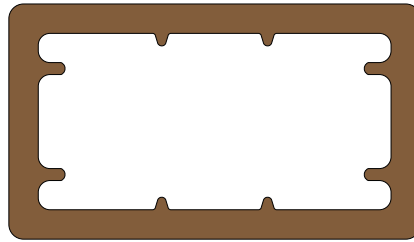

$a = 13/16''$   
 $a = 1''3/4$  in case of installation of the WAJF7040C\_WM cap  
 1= FIXED POINT -  $\emptyset$  hole =  $\emptyset$  screw  
 2= FLOATING POINT -  $\emptyset$  hole =  $2L \times 0.003 + \emptyset$  screw [ft, in]

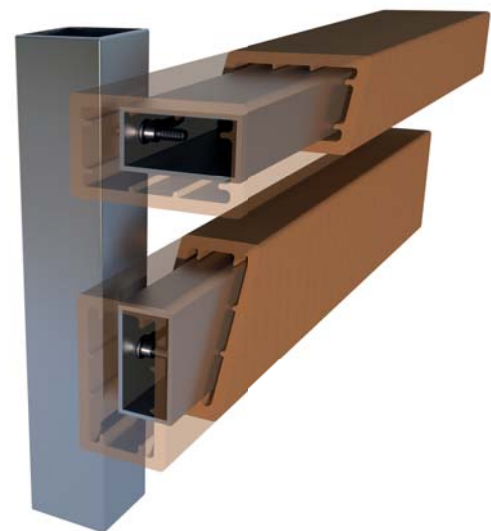

axonometric view

The systems shown are meant as a guide. The drawings show the key points for the design and mounting stages, such as metal reinforcements, fixed point and floating point. All components of the system must be adequately sized and verified by a qualified technician.



1. Create the hole on the aluminum profile as per drawings specs.



2. Include the threaded insert using a pneumatic/electric riveting tool.



3. Pull the trigger, the machine will stop automatically.



4. Well done!

# TZ9555

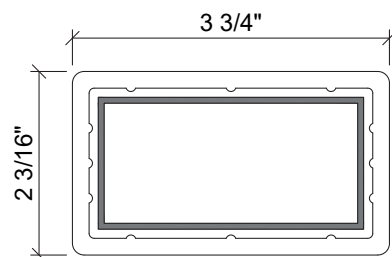

TZ9555

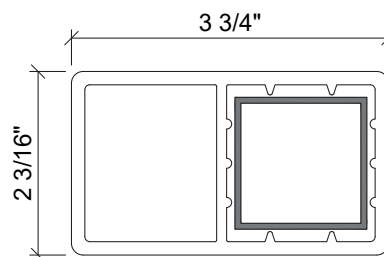

TZ9555-R

Woodn recommends to refer only to the values expressed in mm - the US values are to be considered approximate).



profile code	reinforcement dimensions [ft, in]	side [ft, in]	maximum horizontal span [inch]		maximum vertical span [inch]	
			aluminum	steel	aluminum	steel
<b>TZ9555</b>	80 x 40 x 2 mm (≈ 3"3/16 x 1"5/8 x 5/64")	≈ 3"3/4	≈ 134"	≈ 157"	≈ 134"	≈ 173"
		≈ 2"3/16	≈ 102"	≈ 118"		
<b>TZ9555-R</b>	40 x 40 x 2 mm (≈ 1"5/8 x 1"5/8 x 5/64")	≈ 3"3/4	≈ 98"	≈ 114"	≈ 118"	≈ 153"
		≈ 2"3/16	≈ 94"	≈ 110"		

Maximum spans calculated considering:

- maximum permanent deformation due to own weight 1/8"
- maximum non-permanent deformation 1" 3/16 considering a standard wind load of 30.73 pound/ft<sup>2</sup>

# JF12058-A

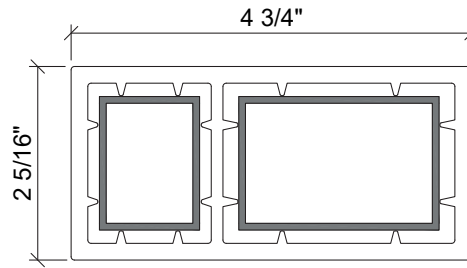

Woodn recommends to refer only to the values expressed in mm - the US values are to be considered approximate).

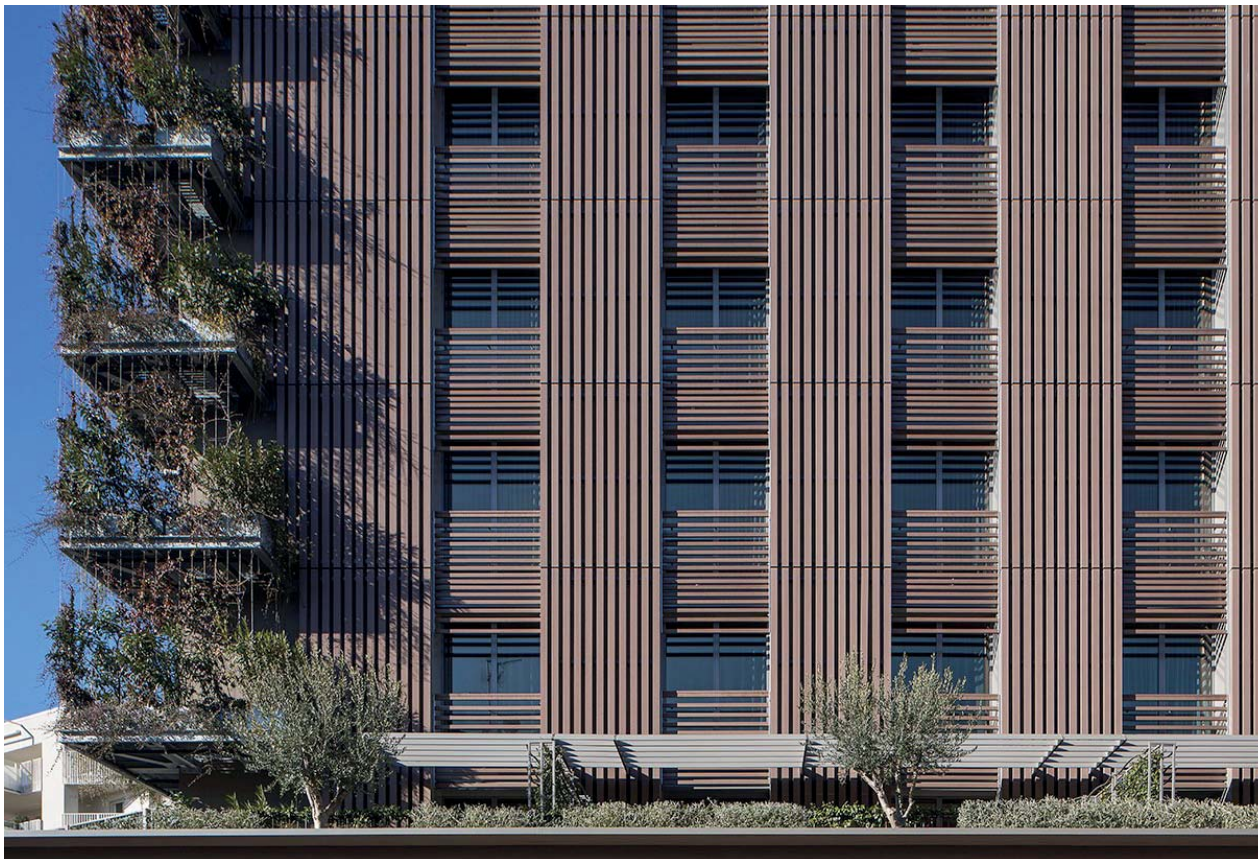

profile code	reinforcement dimensions [ft, in]	side [ft, in]	maximum horizontal span [inch]		maximum vertical span [inch]	
			aluminum	steel	aluminum	steel
<b>JF12058-A</b>	30 x 40 x 2 mm ( $\approx 1\frac{3}{16} \times 1\frac{5}{8} \times 5/64$ )	$\approx 4\frac{3}{4}$	$\approx 75$ "	$\approx 98$ "	$\approx 106$ "	$\approx 138$ "
		$\approx 2\frac{5}{16}$	$\approx 82$ "	$\approx 110$ "		
	60 x 40 x 2 mm ( $\approx 2\frac{3}{8} \times 1\frac{5}{8} \times 5/64$ )	$\approx 4\frac{3}{4}$	$\approx 110$ "	$\approx 145$ "	$\approx 122$ "	$\approx 157$ "
		$\approx 2\frac{5}{16}$	$\approx 94$ "	$\approx 126$ "		

Maximum spans calculated considering:

- maximum permanent deformation due to own weight 1/8"
- maximum non-permanent deformation 1" 3/16 considering a standard wind load of 30.73 pound/ft<sup>2</sup>

# JF11020

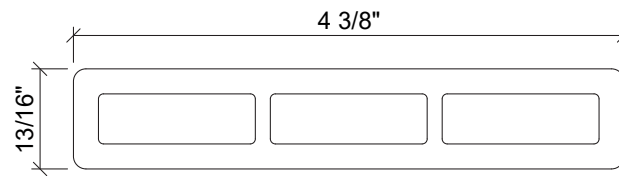

Woodn recommends to refer only to the values expressed in mm - the US values are to be considered approximate).



## PROFILE WITHOUT REINFORCEMENT

profile code	side [ft, in]	maximum horizontal span [inch]	maximum vertical span [inch]
<b>JF11020</b>	≈ 4"3/8	≈ 24"	≈ 24"

## PROFILE WITH REINFORCEMENT

profile code	reinforcement dimensions [ft, in]	side [ft, in]	maximum horizontal span [inch]	maximum vertical span [inch]
<b>JF11020-WA</b>	"L" profile 30 x 10 x 2 mm (≈ 1"3/16 x 7/16" x 5/64")	≈ 4"3/8	≈ 35"	≈ 35"

Maximum spans calculated considering:

- maximum permanent deformation due to own weight 1/8"
- maximum non-permanent deformation 1" 3/16 considering a standard wind load of 30.73 pound/ft<sup>2</sup>

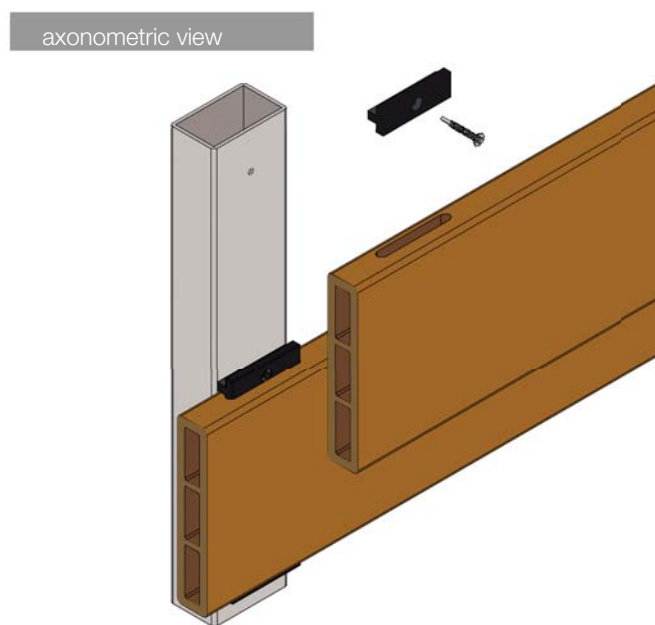
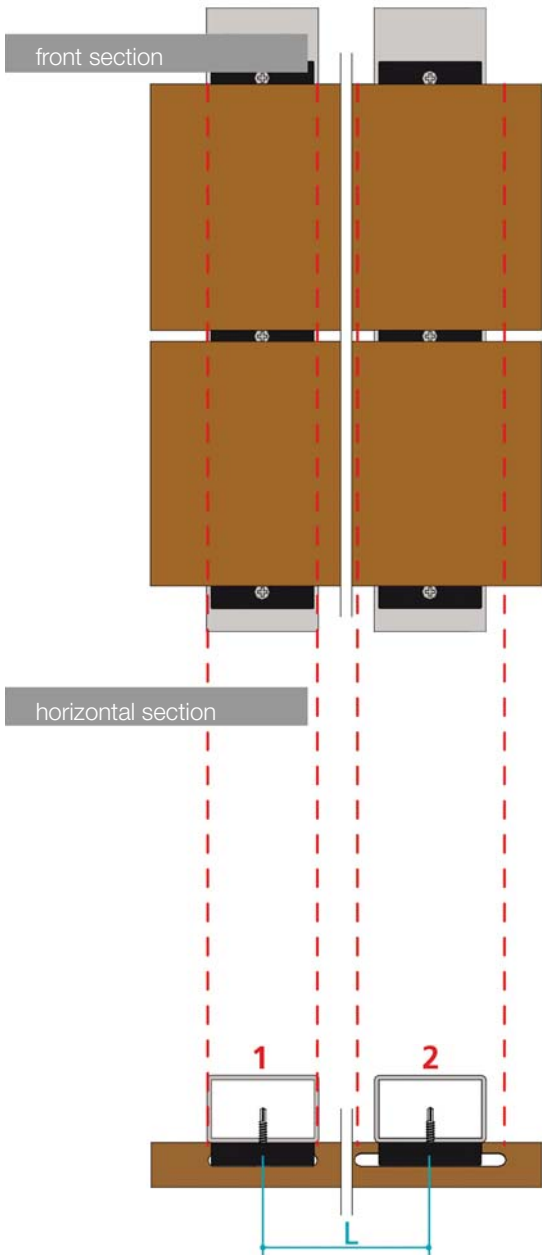
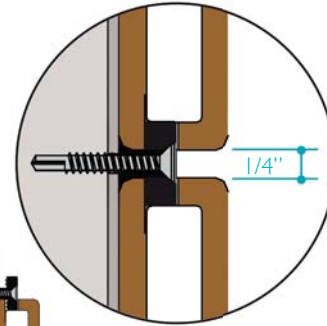
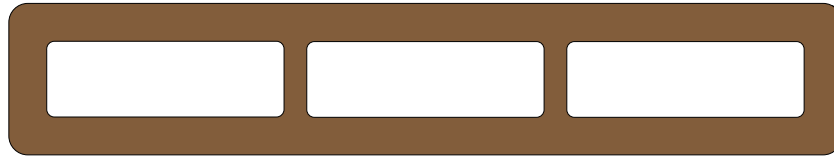

1= FIXED POINT = 1"15/16  
 2= FLOATING POINT = 1"15/16 + 2L x 0.003 [ft, in]

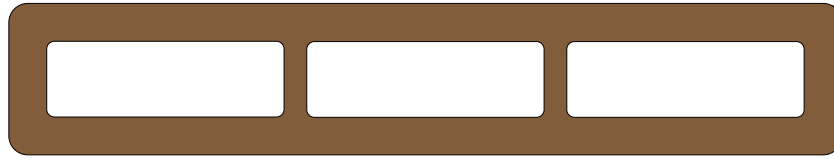

front section

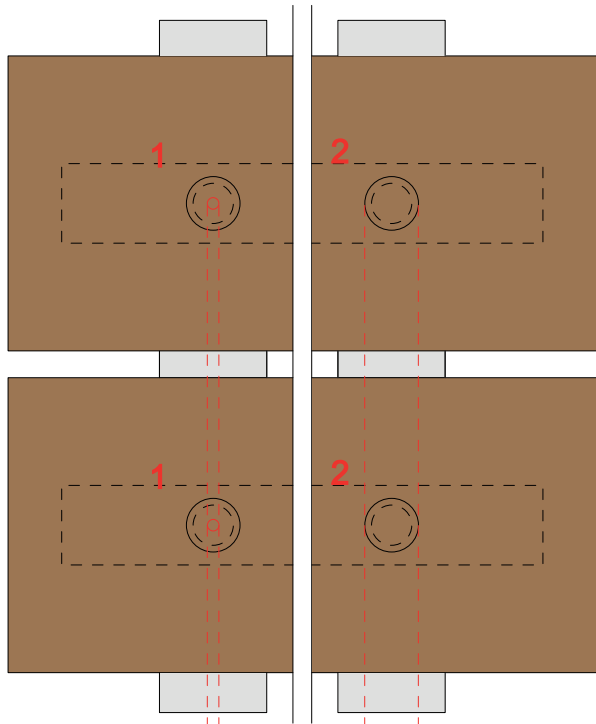

vertical section

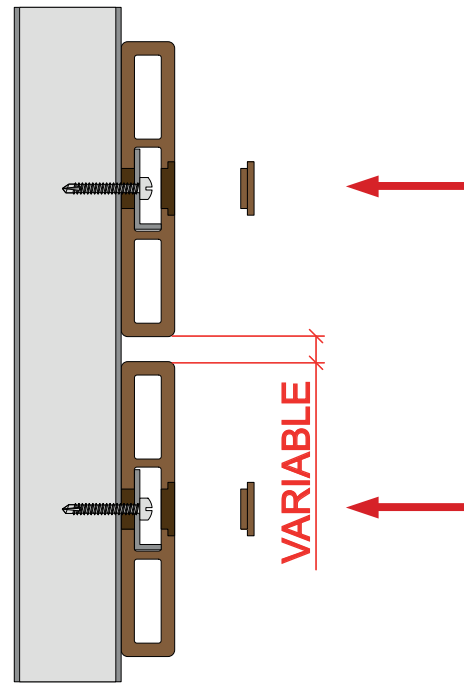

$a = 13/16''$   
 $a = 1''3/4$  in case of installation of the WAJF11020C\_WM cap  
 1= FIXED POINT -  $\emptyset$  hole =  $\emptyset$  screw  
 2= FLOATING POINT -  $\emptyset$  hole =  $2L \times 0.003 + \emptyset$  screw [ft, in]

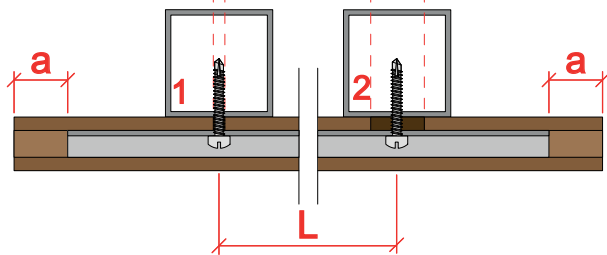

horizontal section

axonometric view



The systems shown are meant as a guide. The drawings show the key points for the design and mounting stages, such as metal reinforcements, fixed point and floating point. All components of the system must be adequately sized and verified by a qualified technician.

# JF18041

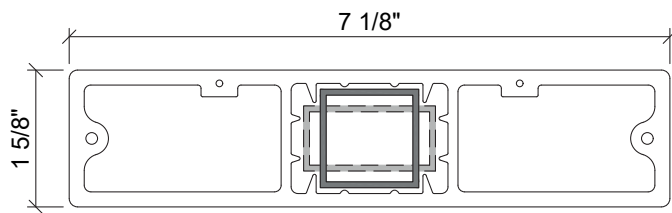

**JF18041**

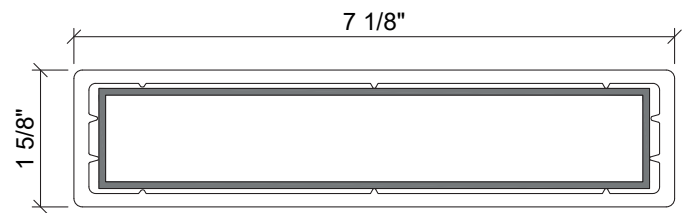

**JF18041-165x30**

Woodn recommends to refer only to the values expressed in mm - the US values are to be considered approximate).



profile code	reinforcement dimensions [ft, in]	side [ft, in]	maximum horizontal span [inch]		maximum vertical span [inch]	
			aluminum	steel	aluminum	steel
<b>JF18041</b>	40 x 20 x 2 mm (≈ 1"5/8 x 13/16" x 5/64")	≈ 7"1/8	≈ 67"	≈ 82"	≈ 71"	≈ 86"
		≈ 1"5/8	≈ 63"	≈ 71"		
	30 x 30 x 2 mm (≈ 1"3/16 x 1"3/16 x 5/64")	≈ 7"1/8	≈ 75"	≈ 98"	≈ 82"	≈ 98"
		≈ 1"5/8	≈ 71"	≈ 86"		
<b>JF18041-165x30</b>	165 x 30 x 2 mm (≈ 6"1/2 x 1"3/16 x 5/64")	≈ 7"1/8	≈ 118"	-	≈ 118"	-
		≈ 1"5/8	≈ 90"	-		

Maximum spans calculated considering:

- maximum permanent deformation due to own weight 1/8"
- maximum non-permanent deformation 1" 3/16 considering a standard wind load of 30.73 pound/ft<sup>2</sup>

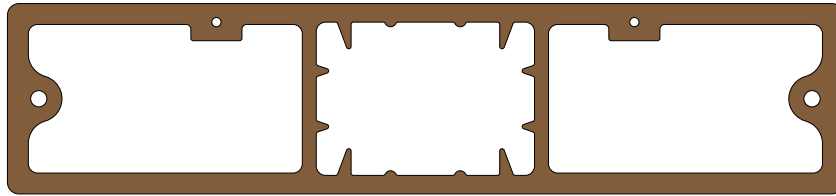

front section

vertical section

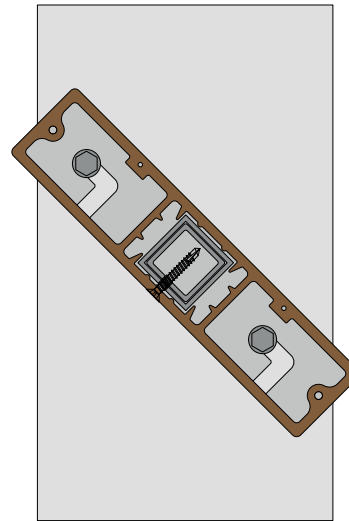
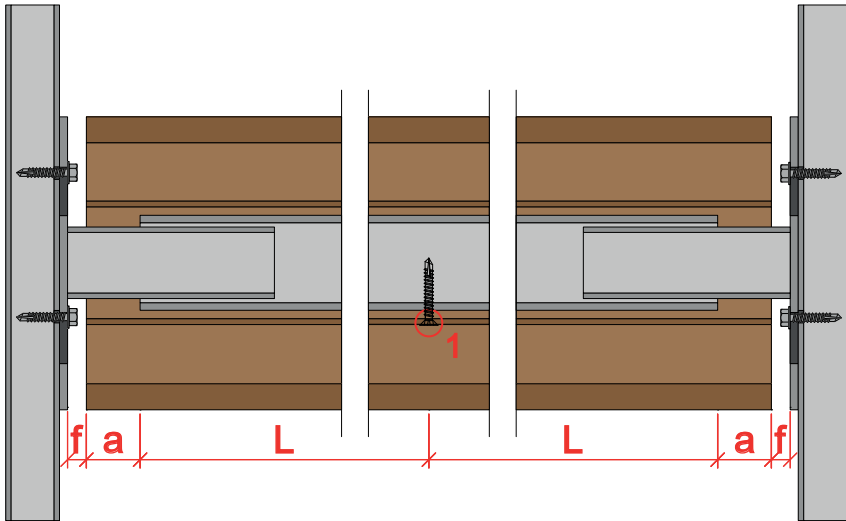

a = 13/16"  
 1 = FIXED POINT - Ø hole = Ø screw  
 f = L x 0.003 [ft, in]

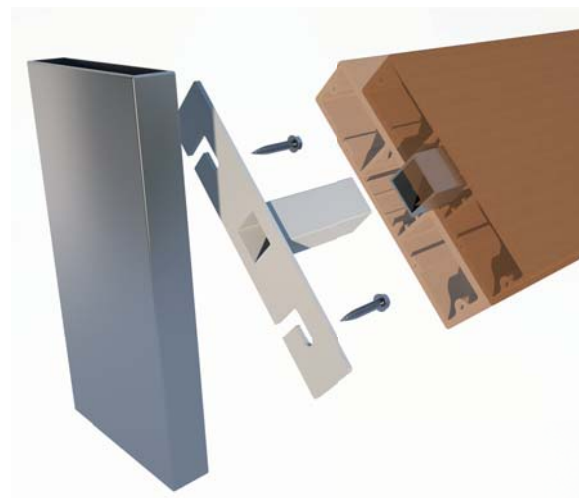
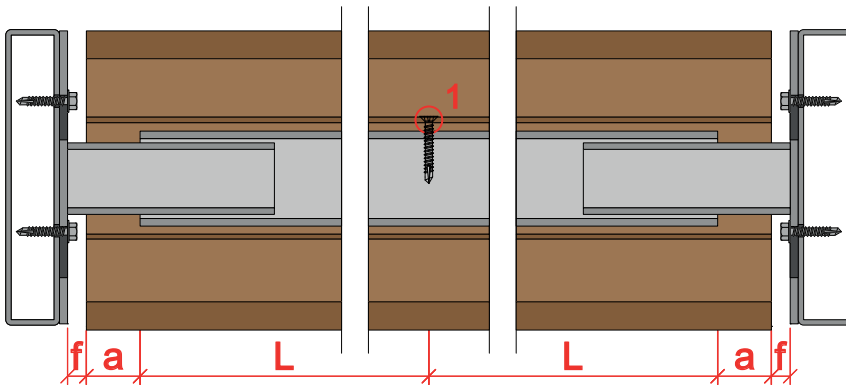

\*brackets available on request

horizontal section

axonometric view

The systems shown are meant as a guide. The drawings show the key points for the design and mounting stages, such as metal reinforcements, fixed point and floating point. All components of the system must be adequately sized and verified by a qualified technician.

# JF222114

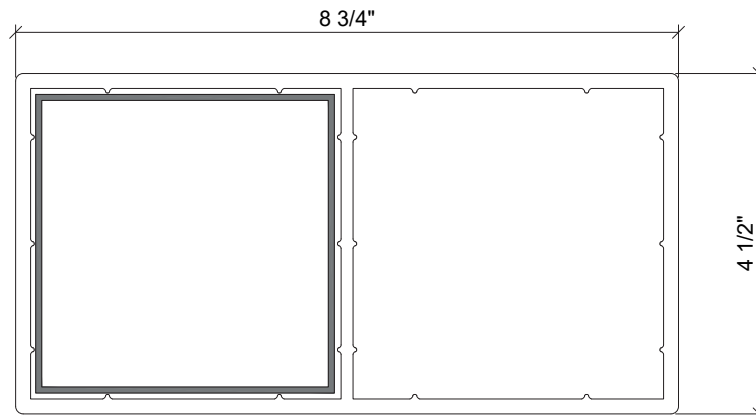

Woodn recommends to refer only to the values expressed in mm - the US values are to be considered approximate).

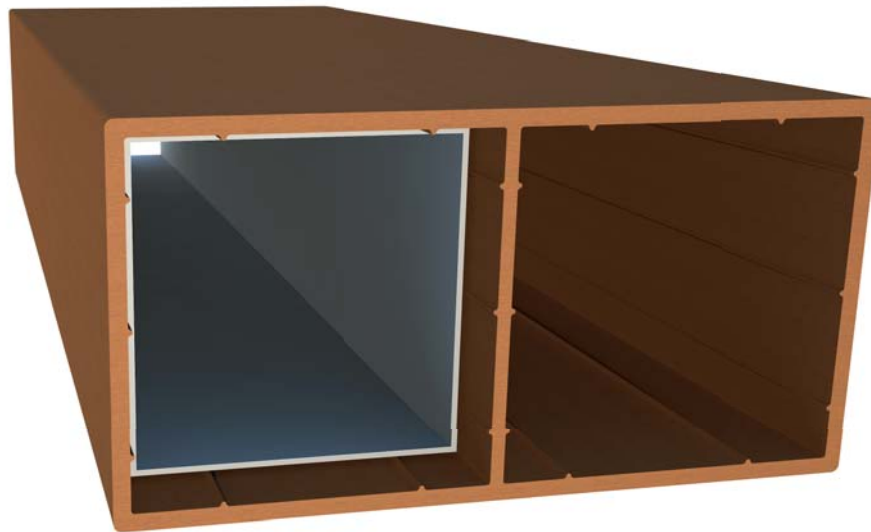

profile code	reinforcement dimensions [ft, in]	side [ft, in]	maximum horizontal span [inch]		maximum vertical span [inch]	
			aluminum	steel	aluminum	steel
<b>JF22214</b>	100 x 100 x 2 mm (≈ 3" 15/16 x 3" 15/16 x 5/64")	≈ 8" 3/4	≈ 165"	≈ 216"	≈ 193"	≈ 256"
		≈ 4" 1/2	≈ 165"	≈ 216"		

Maximum spans calculated considering:

- maximum permanent deformation due to own weight 1/8"
- maximum non-permanent deformation 1" 3/16 considering a standard wind load of 30.73 pound/ft<sup>2</sup>

# TZ6060

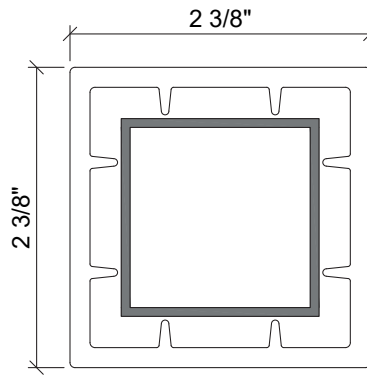

Woodn recommends to refer only to the values expressed in mm - the US values are to be considered approximate).

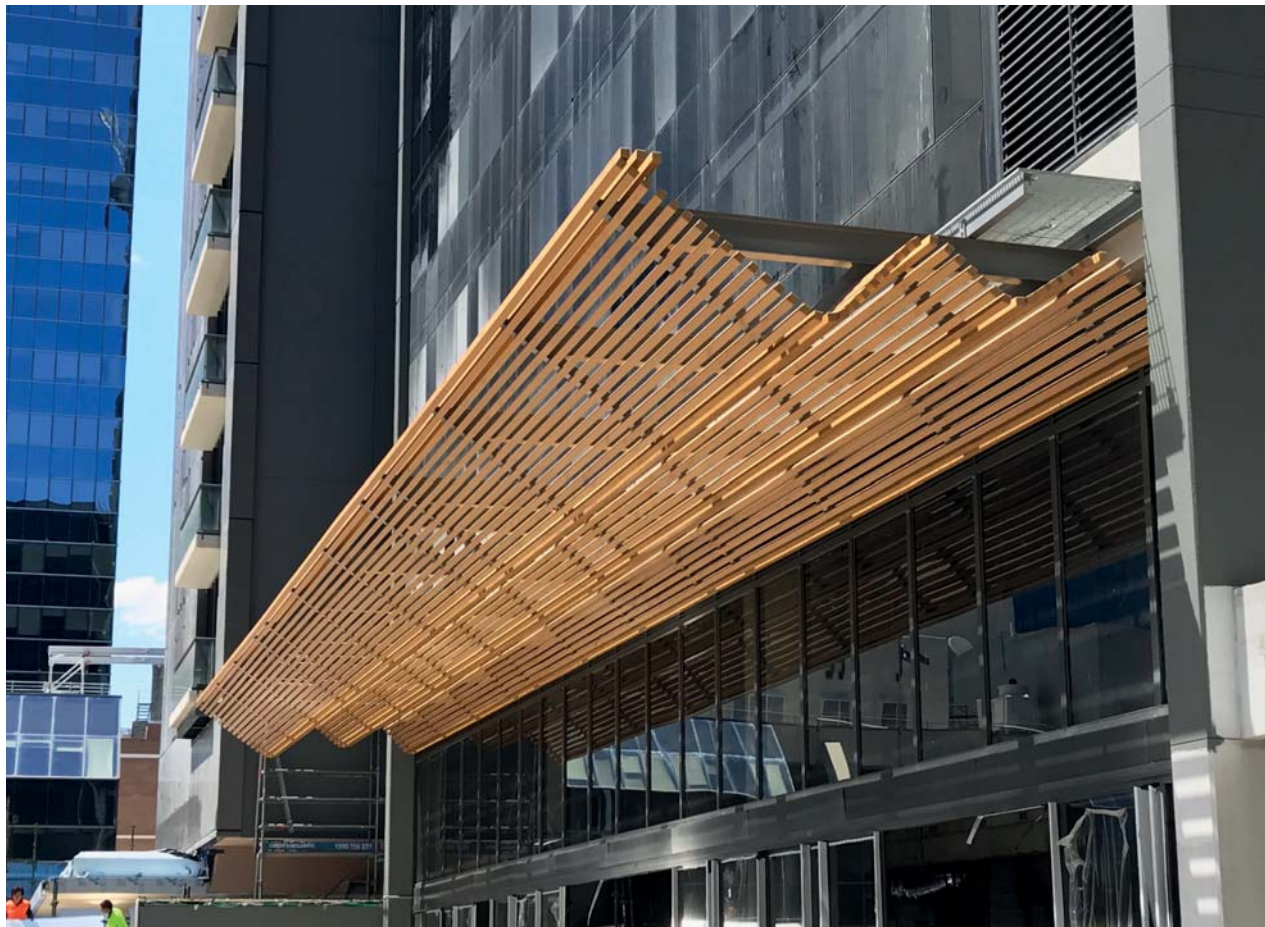

profile code	reinforcement dimensions [ft, in]	side [ft, in]	maximum horizontal span [inch]		maximum vertical span [inch]	
			aluminum	steel	aluminum	steel
<b>TZ6060</b>	40 x 40 x 2 mm ( $\approx 1\frac{5}{8} \times 1\frac{5}{8} \times 5/64$ )	$\approx 2\frac{3}{8}$	$\approx 94$ "	$\approx 110$ "	$\approx 126$ "	$\approx 169$ "

Maximum spans calculated considering:

- maximum permanent deformation due to own weight 1/8"
- maximum non-permanent deformation 1" 3/16 considering a standard wind load of 30.73 pound/ft<sup>2</sup>

# JF7070

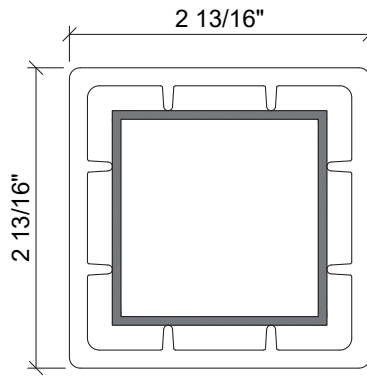

Woodn recommends to refer only to the values expressed in mm - the US values are to be considered approximate).



profile code	reinforcement dimensions [ft, in]	side [ft, in]	maximum horizontal span [inch]		maximum vertical span [inch]	
			aluminum	steel	aluminum	steel
<b>JF7070</b>	50 x 50 x 2 mm (≈ 2" x 2" x 5/64")	≈ 2" 13/16	≈ 98"	≈ 118"	≈ 138"	≈ 181"

Maximum spans calculated considering:

- maximum permanent deformation due to own weight 1/8"
- maximum non-permanent deformation 1" 3/16 considering a standard wind load of 30.73 pound/ft<sup>2</sup>

# TZ113113

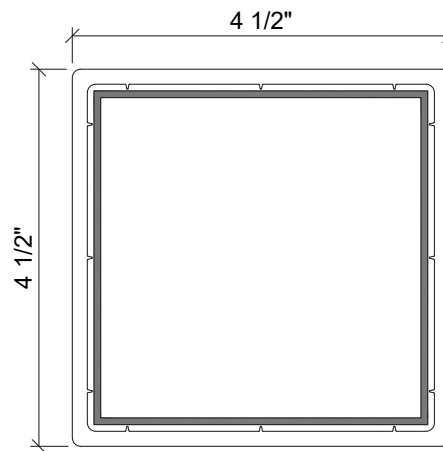

Woodn recommends to refer only to the values expressed in mm - the US values are to be considered approximate).



profile code	reinforcement dimensions [ft, in]	side [ft, in]	maximum horizontal span [inch]		maximum vertical span [inch]	
			aluminum	steel	aluminum	steel
<b>TZ113113</b>	100 x 100 x 2 mm (≈ 3" 15/16 x 3" 15/16 x 5/64")	≈ 4" 1/2	≈ 161"	≈ 185"	≈ 224"	≈ 295"

Maximum spans calculated considering:

- maximum permanent deformation due to own weight 1/8"
- maximum non-permanent deformation 1" 3/16 considering a standard wind load of 30.73 pound/ft<sup>2</sup>

# TZ180180

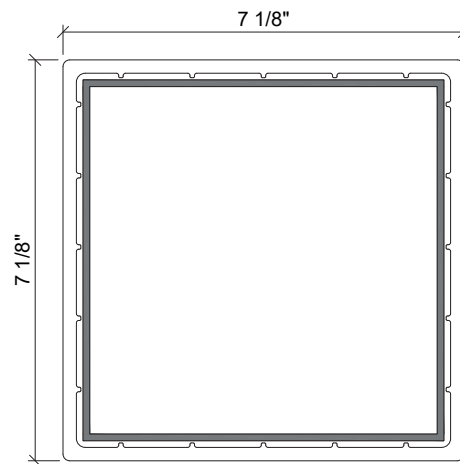

Woodn recommends to refer only to the values expressed in mm - the US values are to be considered approximate).



profile code	reinforcement dimensions [ft, in]	side [ft, in]	maximum horizontal span [inch]		maximum vertical span [inch]	
			aluminum	steel	aluminum	steel
<b>TZ180180</b>	163 x 163 x 3 mm (≈ 6"3/8 x 6"3/8 x 1/8")	≈ 7"1/8	≈ 220"	-	≈ 323"	-

Maximum spans calculated considering:

- maximum permanent deformation due to own weight 1/8"
- maximum non-permanent deformation 1" 3/16 considering a standard wind load of 30.73 pound/ft<sup>2</sup>

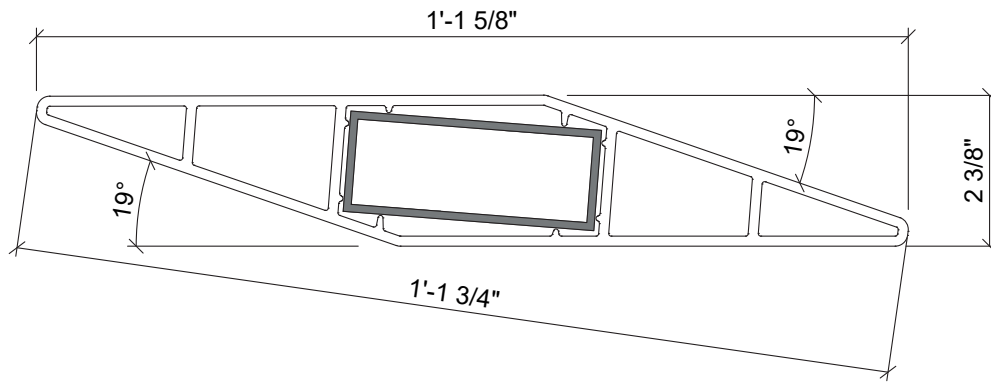

Woodn recommends to refer only to the values expressed in mm - the US values are to be considered approximate).



profile code	reinforcement dimensions [ft, in]	side [ft, in]	maximum vertical span [inch]	
			aluminum	steel
<b>JF35068</b>	100 x 40 x 4 mm (≈ 3" 15/16 x 1" 5/8 x 5/32")	≈ 1' 1" 3/4	≈ 142"	-

Maximum spans calculated considering:

- maximum permanent deformation due to own weight 1/8"
- maximum non-permanent deformation 1" 3/16 considering a standard wind load of 30.73 pound/ft<sup>2</sup>

# C50R

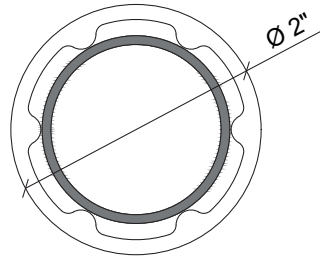

Woodn recommends to refer only to the values expressed in mm - the US values are to be considered approximate).



profile code	reinforcement dimensions [ft, in]	side [ft, in]	maximum horizontal span [inch]		maximum vertical span [inch]	
			aluminum	steel	aluminum	steel
<b>C50R</b>	$\varnothing 38 \times 1,5 \text{ mm}$ ( $\approx \varnothing 1\frac{1}{2} \times 1/16''$ )	$\approx 2''$	$\approx 82''$	-	$\approx 114''$	-

Maximum spans calculated considering:

- maximum permanent deformation due to own weight 1/8"
- maximum non-permanent deformation 1" 3/16 considering a standard wind load of 30.73 pound/ft<sup>2</sup>

# JF15238

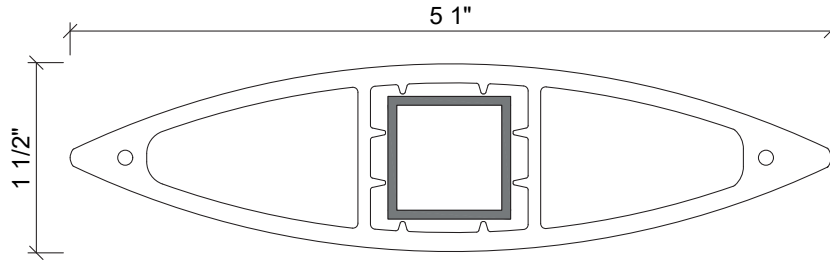

Woodn recommends to refer only to the values expressed in mm - the US values are to be considered approximate).



profile code	reinforcement dimensions [ft, in]	side [ft, in]	maximum horizontal span [inch]		maximum vertical span [inch]	
			aluminum	steel	aluminum	steel
<b>JF15238</b>	25 x 25 x 2 mm (≈ 1" x 1" x 5/64")	≈ 6"	≈ 59"	≈ 82"	≈ 71"	≈ 82"
		≈ 1"1/2	≈ 63"	≈ 79"		

Maximum spans calculated considering:

- maximum permanent deformation due to own weight 1/8"
- maximum non-permanent deformation 1" 3/16 considering a standard wind load of 30.73 pound/ft<sup>2</sup>

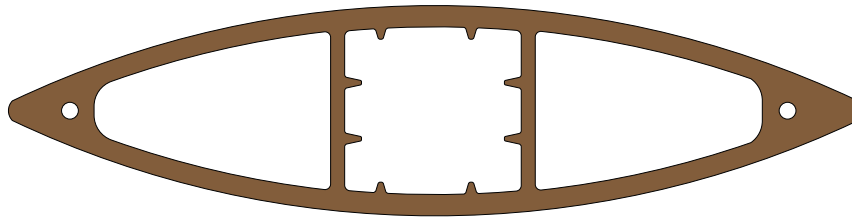

front section

vertical section

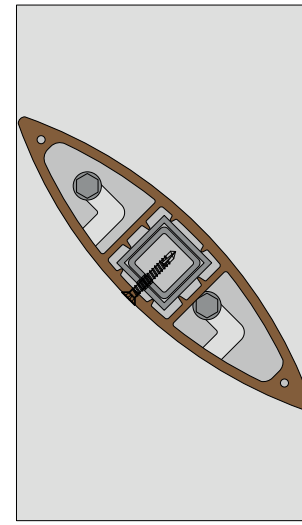
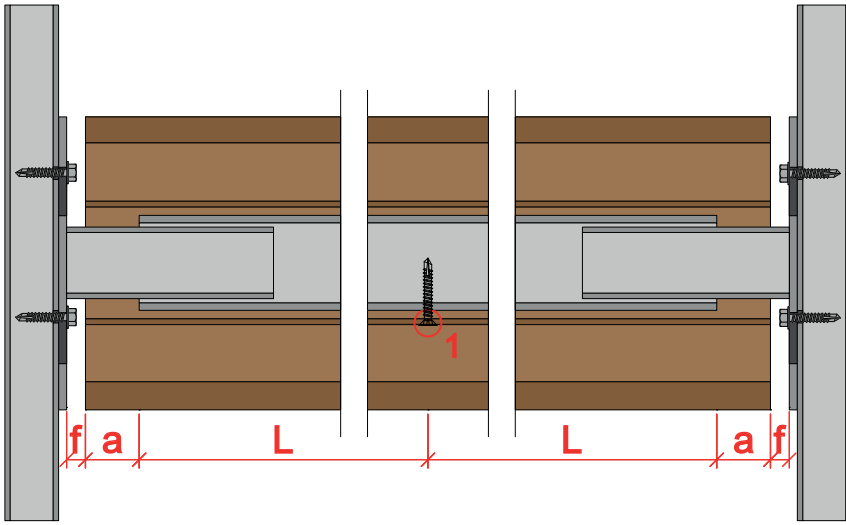

$a = 13/16''$   
 1 = FIXED POINT -  $\varnothing$  hole =  $\varnothing$  screw  
 $f = L \times 0.003$  [ft, in]

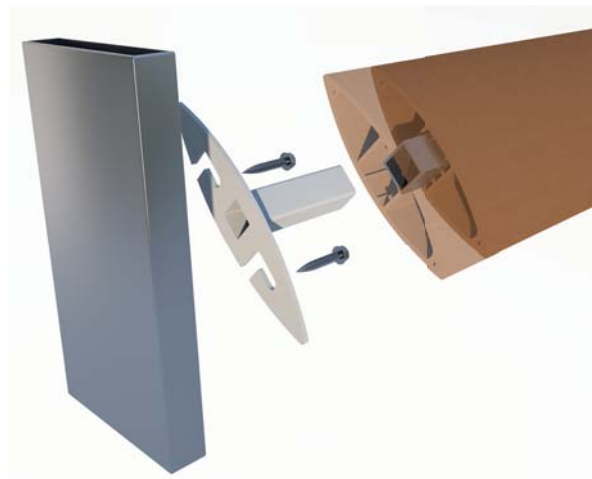
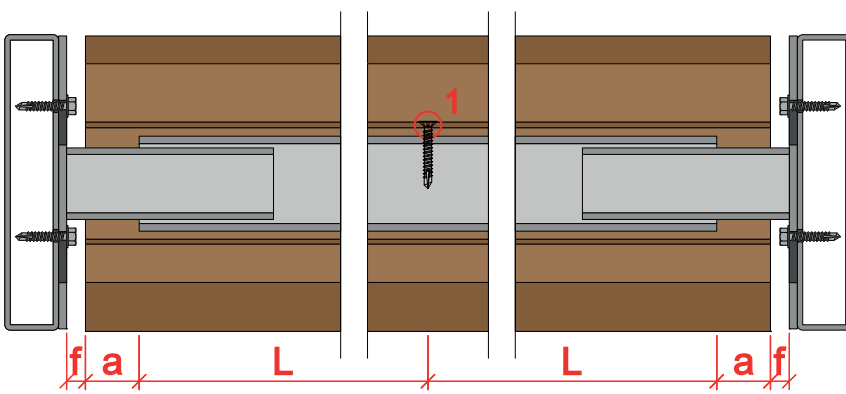

\*brackets available on request

horizontal section

axonometric view

The systems shown are meant as a guide. The drawings show the key points for the design and mounting stages, such as metal reinforcements, fixed point and floating point. All components of the system must be adequately sized and verified by a qualified technician.

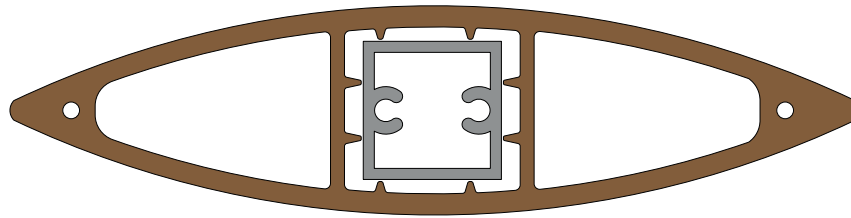

front section

vertical section

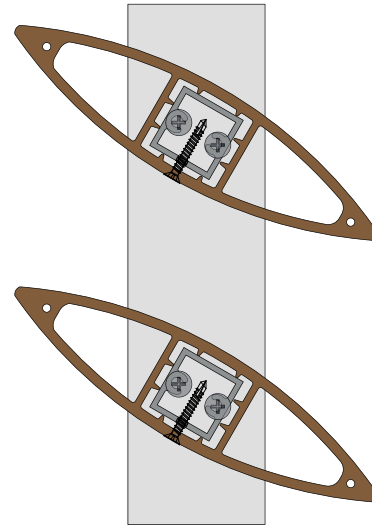
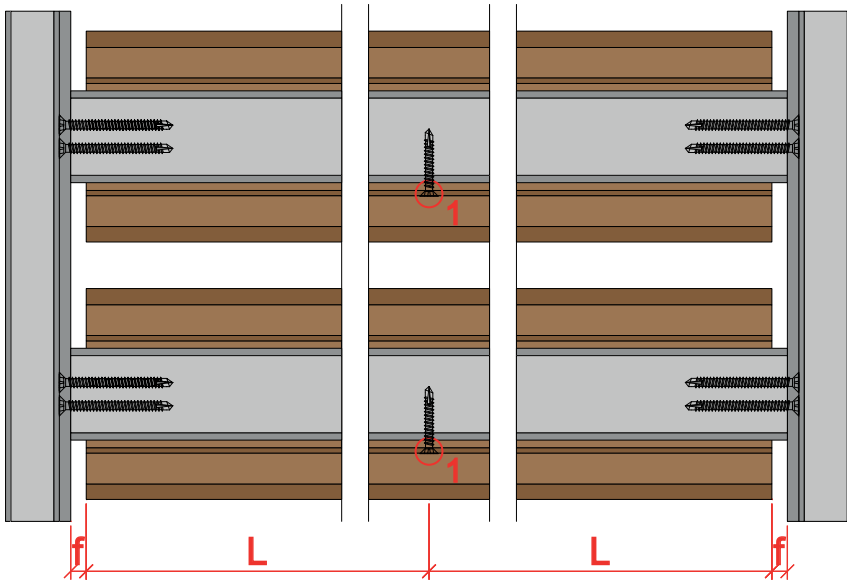

1 = FIXED POINT - Ø hole = Ø screw  
 $f = L \times 0.003$  [ft, in]

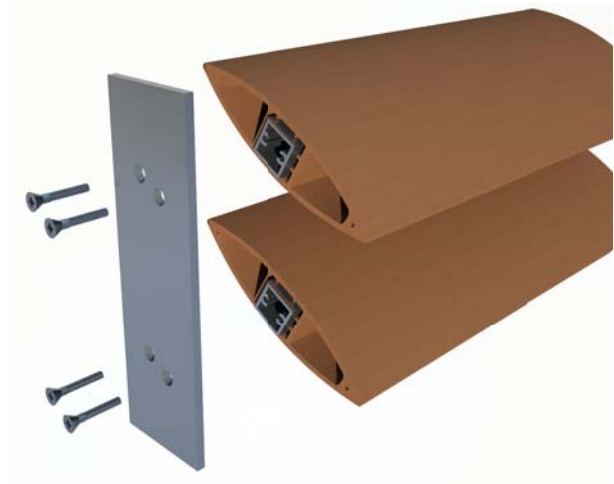
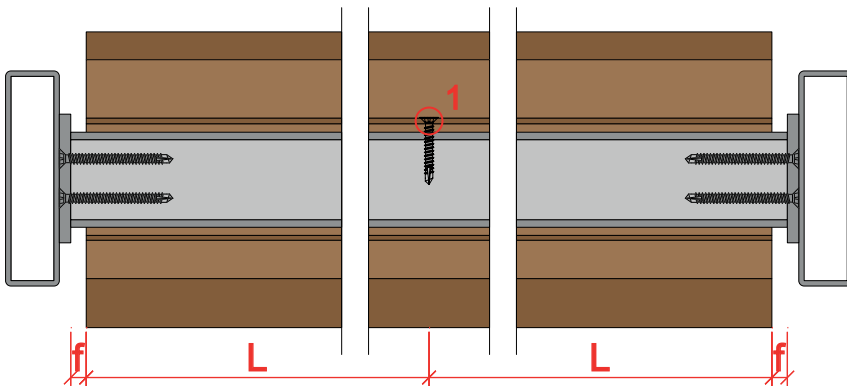

horizontal section

axonometric view

The systems shown are meant as a guide. The drawings show the key points for the design and mounting stages, such as metal reinforcements, fixed point and floating point. All components of the system must be adequately sized and verified by a qualified technician.

# JF20058

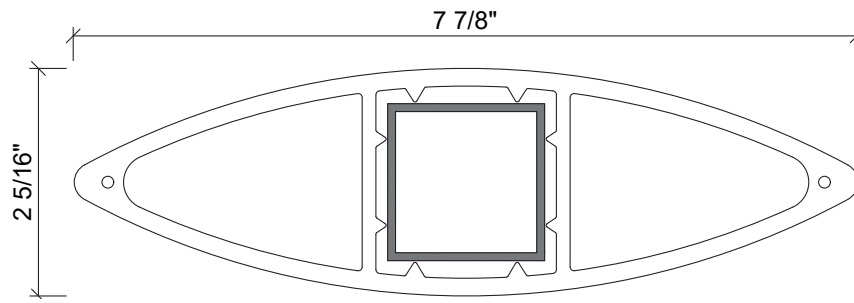

Woodn recommends to refer only to the values expressed in mm - the US values are to be considered approximate).



profile code	reinforcement dimensions [ft, in]	side [ft, in]	maximum horizontal span [inch]		maximum vertical span [inch]	
			aluminum	steel	aluminum	steel
<b>JF20058</b>	40 x 40 x 2 mm (≈ 1"5/8 x 1"5/8 x 5/64")	≈ 7"7/8	≈ 94"	≈ 110"	≈ 98"	≈ 126"
		≈ 2"5/16	≈ 86"	≈ 102"		

Maximum spans calculated considering:

- maximum permanent deformation due to own weight 1/8"
- maximum non-permanent deformation 1" 3/16 considering a standard wind load of 30.73 pound/ft<sup>2</sup>

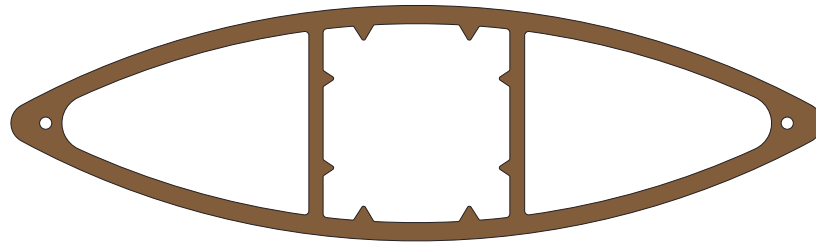

front section

vertical section

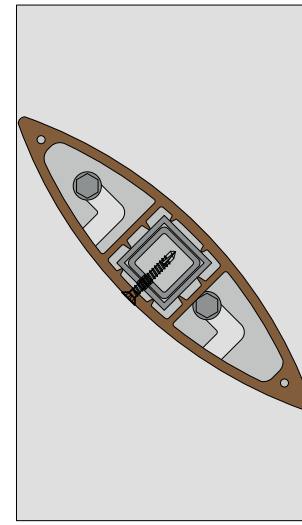
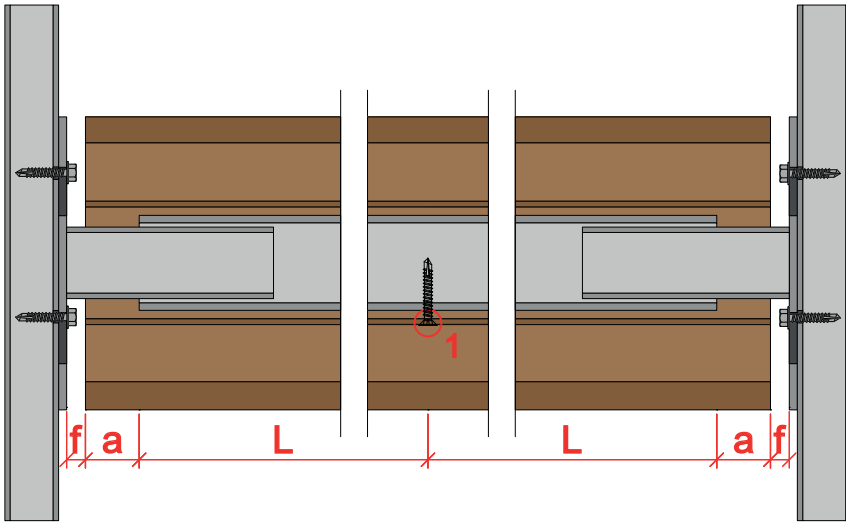

$a = 13/16''$   
 1= FIXED POINT -  $\varnothing$  hole =  $\varnothing$  screw  
 $f = L \times 0.003$  [ft, in]

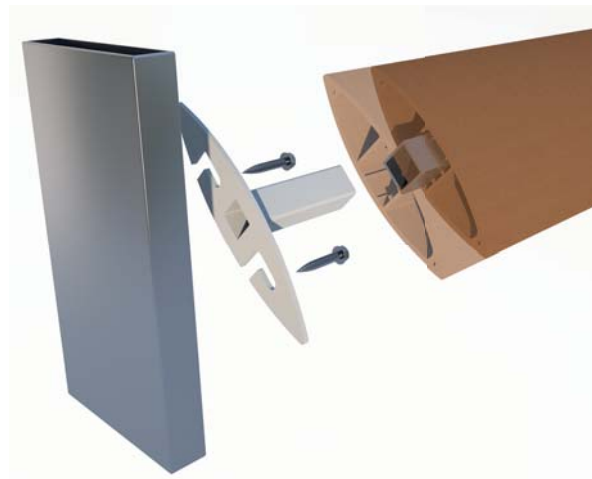
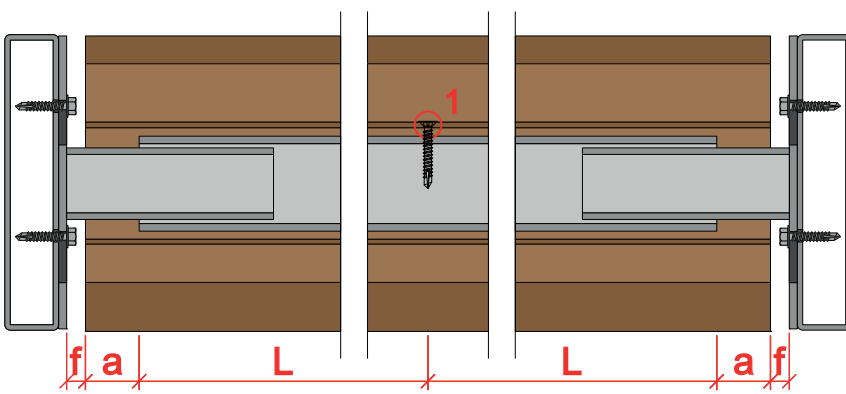

\*brackets available on request

horizontal section

axonometric view

The systems shown are meant as a guide. The drawings show the key points for the design and mounting stages, such as metal reinforcements, fixed point and floating point. All components of the system must be adequately sized and verified by a qualified technician.

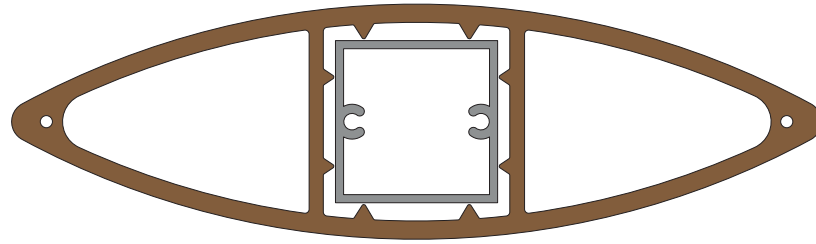

front section

vertical section

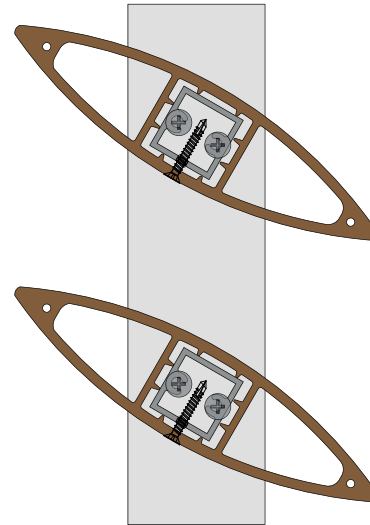
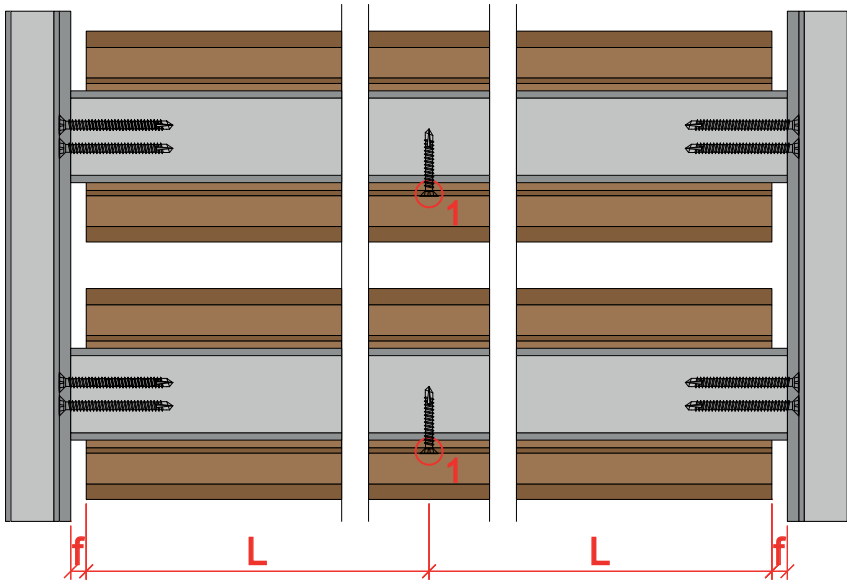

1 = FIXED POINT - Ø hole = Ø screw  
 $f = L \times 0.003$  [ft, in]

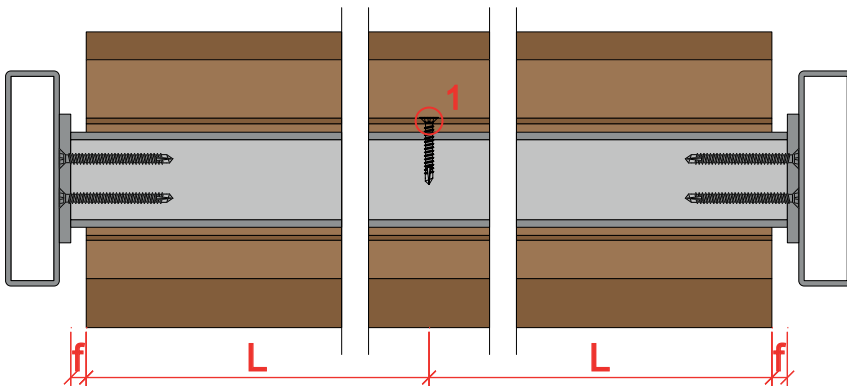

horizontal section

axonometric view

The systems shown are meant as a guide. The drawings show the key points for the design and mounting stages, such as metal reinforcements, fixed point and floating point. All components of the system must be adequately sized and verified by a qualified technician.

# JF15045-25

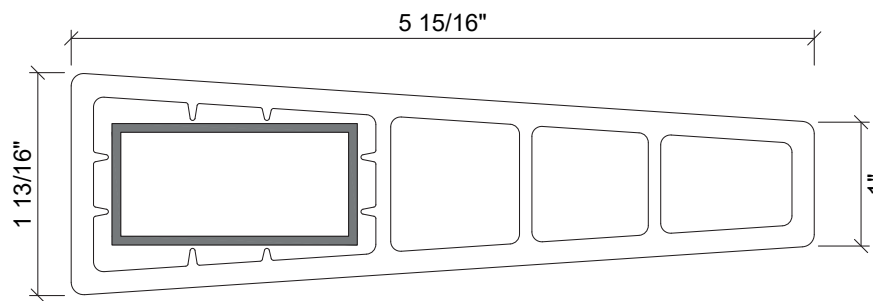

Woodn recommends to refer only to the values expressed in mm - the US values are to be considered approximate).

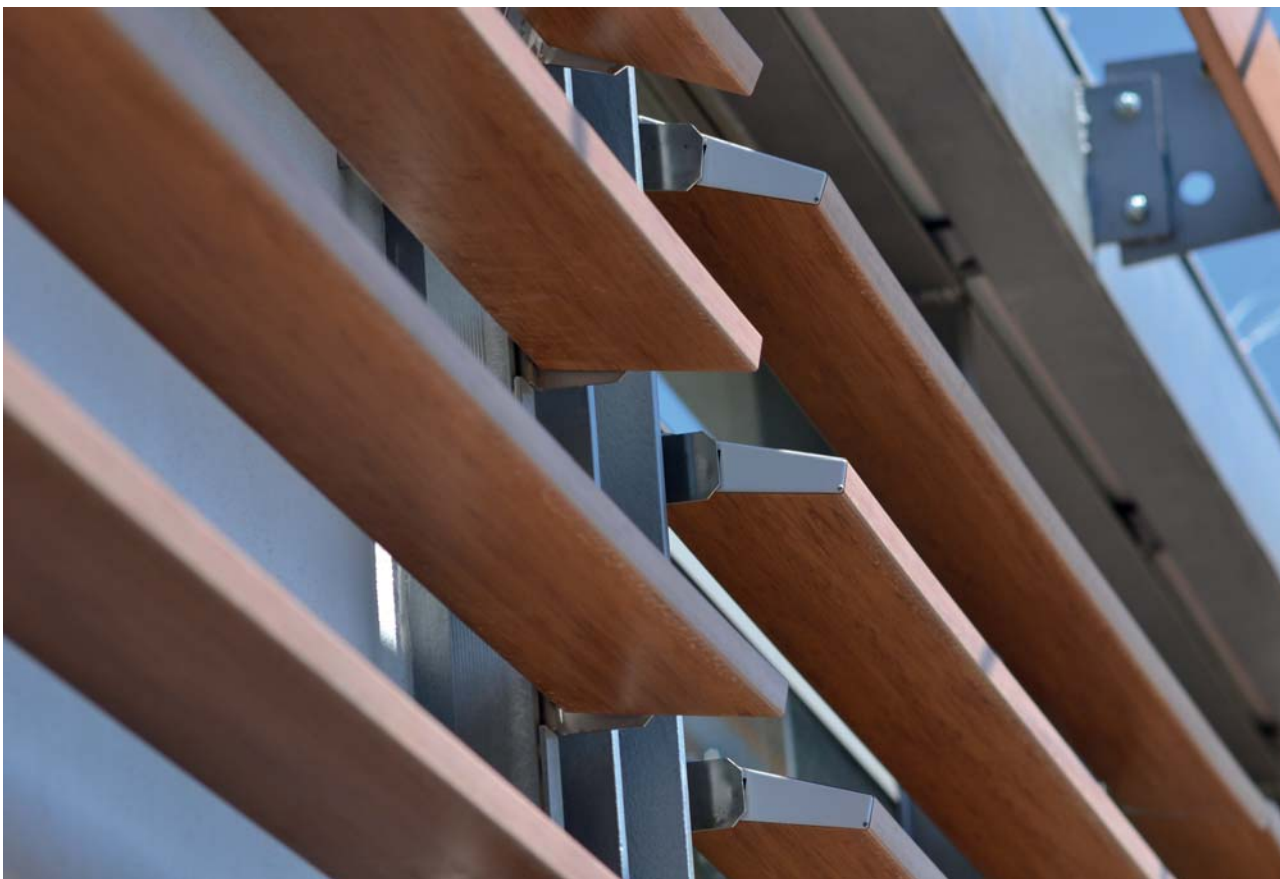

profile code	reinforcement dimensions [ft, in]	side [ft, in]	maximum horizontal span [inch]		maximum vertical span [inch]	
			aluminum	steel	aluminum	steel
<b>JF15045-25</b>	50 x 25 x 2 mm (≈ 2" x 1" x 5/64")	≈ 5"15/16	≈ 75"	≈ 106"	≈ 86"	≈ 110"
		≈ 1"13/16	≈ 71"	≈ 86"		

Maximum spans calculated considering:

- maximum permanent deformation due to own weight 1/8"
- maximum non-permanent deformation 1" 3/16 considering a standard wind load of 30.73 pound/ft<sup>2</sup>

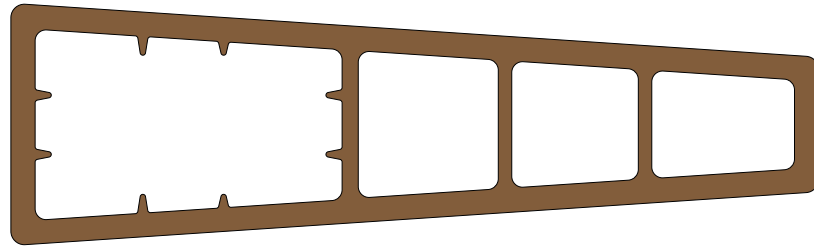

front section

vertical section

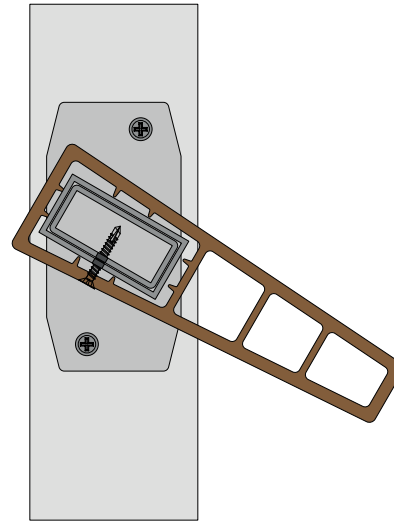
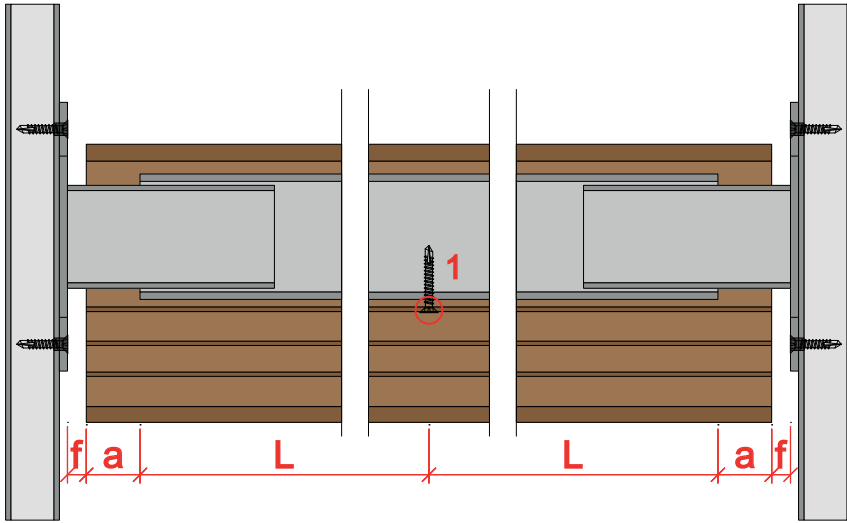

$a = 13/16''$   
 1= FIXED POINT -  $\varnothing$  hole =  $\varnothing$  screw  
 $f = L \times 0.003$  [ft, in]

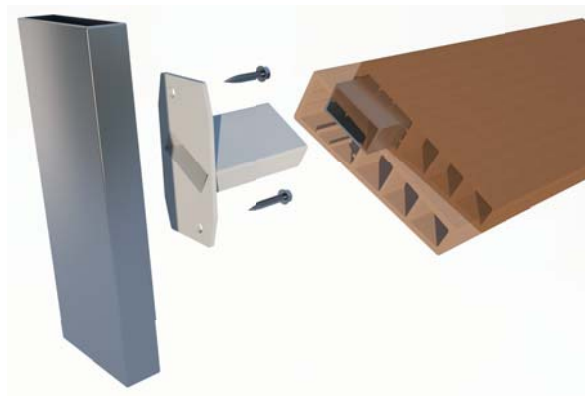
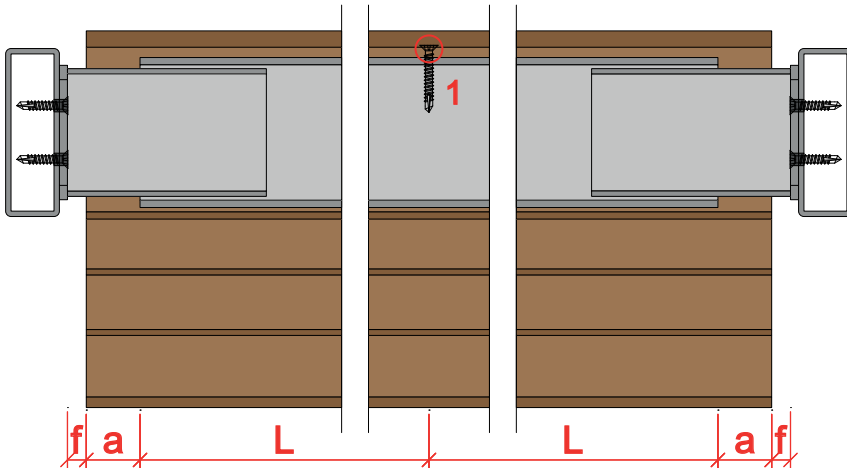

\*brackets available on request

horizontal section

axonometric view

The systems shown are meant as a guide. The drawings show the key points for the design and mounting stages, such as metal reinforcements, fixed point and floating point. All components of the system must be adequately sized and verified by a qualified technician.

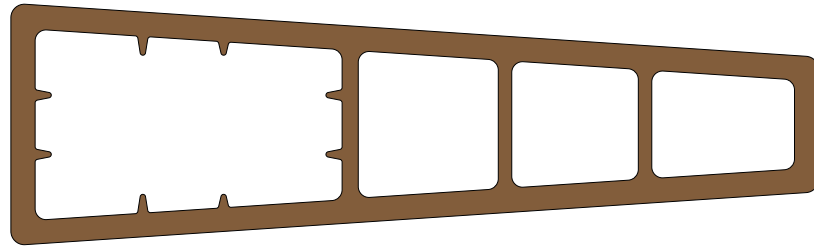

front section

vertical section

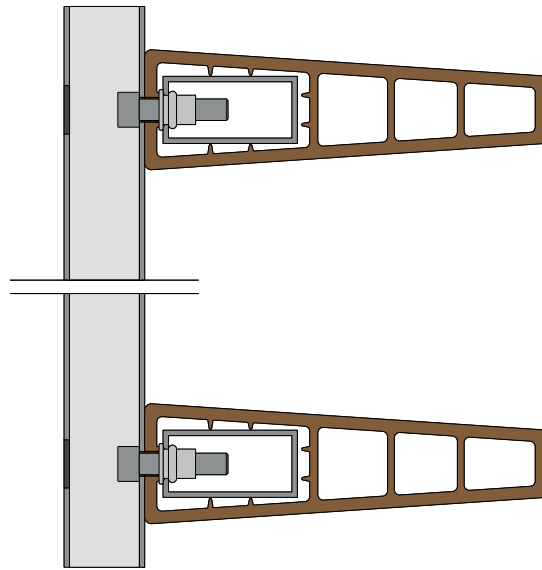
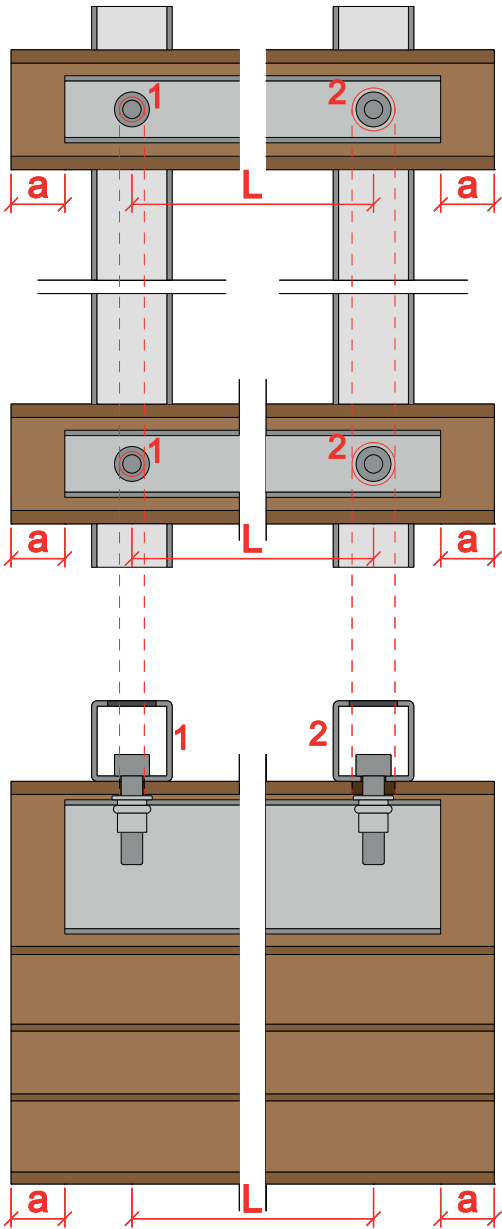



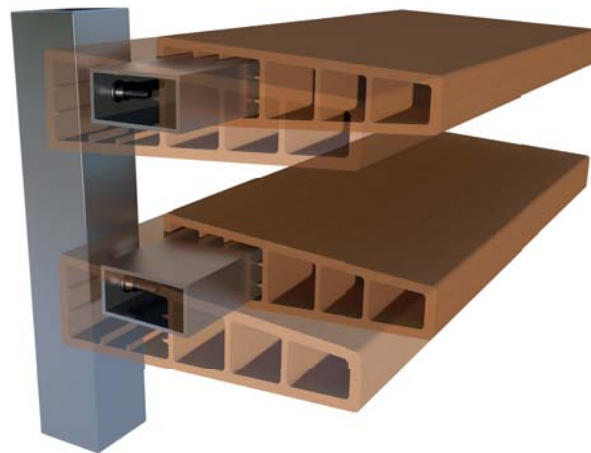









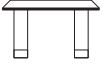
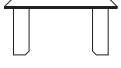
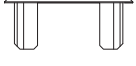

$a = 13/16''$   
 $a = 1''3/4$  in case of installation of the WAJF15045C\_WM cap  
 1= FIXED POINT -  $\varnothing$  hole =  $\varnothing$  screw  
 2= FLOATING POINT -  $\varnothing$  hole =  $2L \times 0.003 + \varnothing$  screw [ft, in]

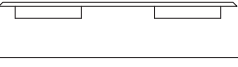





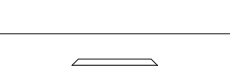

horizontal section

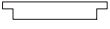
axonometric view

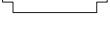
The systems shown are meant as a guide. The drawings show the key points for the design and mounting stages, such as metal reinforcements, fixed point and floating point. All components of the system must be adequately sized and verified by a qualified technician.

accessory code	design	compatible profiles	material	colour
<b>WALG3020C-WM</b>		LG3020	Woodn	All
<b>WAJF4030C-WM</b>		JF4030	Woodn	All
<b>WAJF5026C-WM</b>		JF5026	Woodn	All
<b>WAJF6032C-WM</b>		JF6032	Woodn	All
<b>WAJF7040C-WM</b>		JF7040-25x25 JF7040-30x15 JF7040-50x25	Woodn	All
<b>WATZ9555C-WM</b>		TZ9555 TZ9555-R	Woodn	All
<b>WAJF11020C-WM</b>		JF11020	Woodn	All
<b>WAJF12058C-WM</b>		JF12058	Woodn	All
<b>WAJF18041C-WM</b>		JF18041	Woodn	All
<b>WAJF18041-165C-WM</b>		JF18041-165x30	Woodn	All
<b>WATZ6060C-WM</b>		TZ6060	Woodn	All
<b>WAJF7070C-WM</b>		JF7070	Woodn	All
<b>WATZ113113C-WM</b>		TZ113113	Woodn	All
<b>WATZ180180C-WM</b>		TZ180180	Woodn	All
<b>WAJF15045C-WM</b>		JF15045-25	Woodn	All
<b>WAC50C-WM</b>		C50	Woodn	All

accessory code	design	nominal dimensions [ft, in]	material	colour
<b>ROUND CAP RC20-25</b>		Ø 20 - 25 mm (≈ Ø 13/16" - 1")	Woodn	All
<b>ROUND CAP RC25-30</b>		Ø 25 - 30 mm (≈ Ø 1" - 1 3/16")	Woodn	All
<b>ROUND CAP RC30-35</b>		Ø 30 - 35 mm (≈ Ø 1 3/16" - 1 7/16")	Woodn	All
<b>ROUND CAP RC35-40</b>		Ø 35 - 40 mm (≈ Ø 1 7/16" - 1 9/16")	Woodn	All
<b>ROUND CAP RC40-45</b>		Ø 40 - 45 mm (≈ Ø 1 9/16" - 1 6/8")	Woodn	All
<b>ROUND CAP RC45-50</b>		Ø 45 - 50 mm (≈ Ø 1 6/8" - 2")	Woodn	All

NOTE: Woodn recommends to refer only to the values expressed in mm the US values are to be considered approximate). If end caps of different sizes are needed, they will be evaluated according to project's needs.

## INSTALLATION OF THE END CAPS

### Woodn interlocking caps (WAJF7040C-WM and similar)

All caps made of Woodn are supplied in sanded finish/surface, regardless the surface finish of the Versatilis profile surface. Remove any residual material from the profile due to cutting and with a dry cloth remove any remaining dust. Remove the protective film from the adhesive strips placed under the cap. Insert the cap into the profile, make sure it is centered. Apply light pressure with your hand to ensure the adhesive strips adhere well. If possible, mechanically fasten the caps on both sides of the profile with staples. For a better fixing, we recommend the use of WEISS CHEMIE COSMO SL-660.130 glue.

Follow the reported instructions to install end caps with a structure similar to the ones reported here above. If you have any doubts, please contact Woodn Industries' technical office at [ufficiotecnico@woodn.com](mailto:ufficiotecnico@woodn.com).



# GREENWOOD GREENDECK



#### DISCLAIMER - GENERAL NOTES

Due to conversion from metric sizes and measurements, the US values provided are approximate.

The information provided by WoodN Industries in this document are solely indicative, they are based on the present state of knowledge and must be considered only as a description of our products and their possible application. Such information must not be interpreted as a guarantee of specific features, performances or warranties of the product. Material's colors and finishes represented in this document are the result of printing techniques so they may slightly differ from the original colors. Original samples are available upon request and constitute only a general indication of the dimensions and the aesthetic appearance of Woodn™ profiles. WoodN Industries may change the information included in this document at any time and without further notice. WoodN Industries does not warrant the accuracy and completeness of the information in this document and furthermore their suitability for the purpose which it is consulted for by the other parties. WoodN's customers or third parties must ascertain they have the most recent version of this document, available at [www.woodn.com](http://www.woodn.com). It is advised that customers and third parties have a professional adviser to inform them about the suitability of the products for all desired applications and about applicable laws and regulations. WoodN Industries reserves the right to modify products and concerning features without prior notice. WoodN Industries is not liable for any damage arising from, or related to, the use of this document. Woodn™ material does not have structural characteristics and therefore WoodN Industries declines all responsibilities for improper use of the material. No sections of this publication can be reproduced, stored in database, or transmitted in any form or by any other mean without the explicit approval of WoodN Industries. For more information please contact WoodN Industries.

# MATERIAL'S FEATURES

## Mechanical properties

Flexural elastic modulus	UNI EN ISO 178:2003	3300 Mpa
Flexural strength	UNI EN ISO 178:2003	25 Mpa
Elastic tensile modulus	EN ISO 527:1996	3300 Mpa
Tensile strength	EN ISO 527:1996	12 Mpa
Elongation at break	EN ISO 527:1996	0,78 %
Charpy impact resistance	EN ISO 179-1:2007	5,65 KJ/m <sup>2</sup>
Coefficient of linear thermal expansion longitudinal (from -10 °C to 45 °C)	TMA ASTM E 831/2005	33,3 x10 <sup>-6</sup> m/(m°C)

## Reaction to fire

Reaction to fire (critical flux)	UNI EN 9239-1:2006	2,24 kW/ m <sup>2</sup>
----------------------------------	--------------------	-------------------------

## Chemical and biological features

Mold/mildew resistance	ASTM G21:2009	Fungal growth: no visible growth
------------------------	---------------	----------------------------------

## Surface characteristics

Slip resistance, USRV coefficient	UNI ENV 12633:2006	> 52
Friction coefficient	B.C.R.A. Rep. CEC. 6/81	> 0.4



The values shown are indicative and not binding. Test reports available upon request.  
 The natural aging of the material and temperature variations may cause deviations from the values indicated above.  
 The product is protected by a warranty in line with legal requirements: for more information see the SPECS on [www.woodn.com](http://www.woodn.com)

# GREENDECK - outdoor decking



Woodn recommends to refer only to the values expressed in mm the US values are to be considered approximate).



## PLANKS DIMENSION AND LOGISTIC



Code	TV01
Dimensions of the plank	161 x 22 x 1830 mm (≈ 6"11/32 x 7/8" x 6')
Incidence	1,86 ft/sqft
Weight of a plank	≈ 2,60 lb/ft

The external dimensions listed are nominal values.  
The weights of the planks indicated in the tables are indicative and not binding.  
Length tolerances according UNI EN-ISO 22768: class UNI EN-ISO 22768-vL.

## System height

LAYING ON ALUMINUM JOISTS 2"3/16 x 13/16" (W x H)

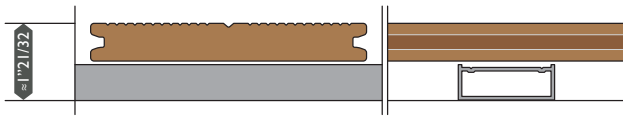

LAYING ON ALUMINUM JOISTS AND CROSSPIECES 2"3/16 x 13/16" (W x H) WITH SUPERIMPOSED FRAME

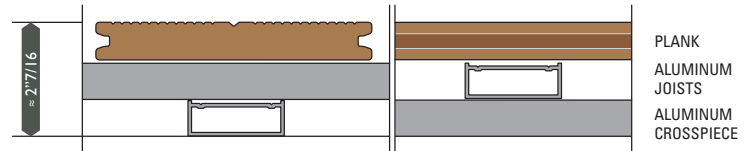

## Size of the joints

Clip model	Joint size [ft]
Stainless steel clip (code ZCLG-AC001)	Approximately 5 mm ( $\approx 3/16"$ ) *

\*IMPORTANT: The dimensions shown are approximate and may vary depending on the accuracy, tolerance and method of installation.

## Laying instructions

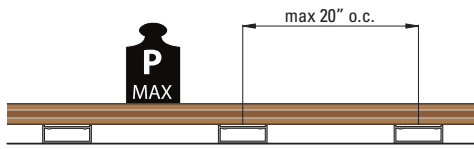

The Greendeck floor is suitable for foot traffic, but not vehicle traffic.

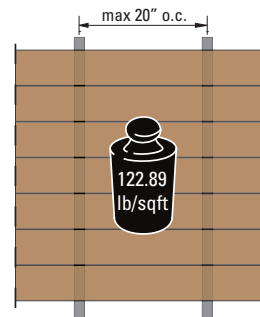

Load distributed over 1 sqft

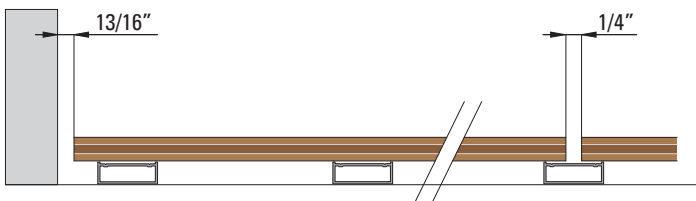

The minimum distance between the ends of the plank and the wall must be at least 20 mm ( $\approx 13/16"$ ).

The minimum distance between the ends of two consecutive planks must be 5-7 mm ( $\approx 1/4"$ ) for planks 6' long.

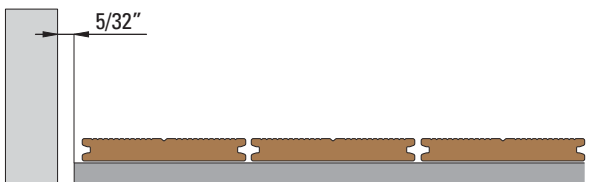

The distance between the joist and the wall must be at least 4 mm ( $\approx 5/32"$ ) regardless of the width of the surface.



Position the joist no more than 30 mm ( $\approx 1 3/16"$ ) from the end of the plank.

WARNING: it has to be noted that the failure to comply strictly with the criteria for a correct installation, causes the deformation of the materials and the misalignment of all the expansion joints.

# GENERAL INSTALLATION INSTRUCTIONS

Key points to be followed before and during the installation process:

- Store the material on a flat surface providing for a stable support on the whole surface, in a dry, clean area, protected from frost and direct sun light.
- Before starting the installation, carefully check the material and notify immediately of any manufacturing issues. Complaints will not be accepted after installation.
- Before starting the installation, check project's drawings (or shop drawings if provided) and the correspondence of the received material against the packing list.
- Acclimate the material in stock to the temperature of the jobsite for at least 48 hours prior to installation.
- The installation temperature must be higher than 32 °F.
- Do not cover the product with sheets made with non-breathable material (nylon, polyethylene and similar materials). For this purpose it is advisable to use breathable material such as painter felt sheets.
- The accumulation of electrostatic charges is a natural phenomenon commonly found in plastic materials, and under exceptional environmental conditions this may also occur in Greenwood products.
- Profiles shall be handled with care in order to prevent damages. It is recommended to lift the profiles on the whole length during displacement and not make them slide on top of each other. Always use clean fabric gloves when handling profiles.
- Prevent the formation of dirt on and between profiles; in particular, make sure that mechanical processes carried out on other materials, near Greenwood products, do not determine the accumulation of chips or dust of any kinds. During the installation/assembly phase do not apply any label or sticker; if already applied, please remove immediately after installation. Immediately remove major stains such as paint, concrete or tar residues.
- For cleaning and maintenance instructions refer to page 115. The WoodN Industries warranty will be rendered null and void in the event of incorrect or improper handling, cleaning and maintenance.

## EXPANSION GAP BETWEEN ADJACENT PROFILES AND WALLS

The composite wood being subject to limited expansion, due to temperature changes and limited water absorption, there must be maintained a lateral distance of around 3/16" between individual boards. This distance is provided automatically by the use of the clip which at the same time carries out the functions of template and spacer during fixing operations.

The heads of the boards must always rest on a substructure. The clips should be positioned in line with the substructure profile to fix both ends of the boards.

Maintain distances of 1"3/16 from the rigid structures present in the vicinity of the decking. In the head joints there must be a distance between the boards of 1/4" (for 6' long pieces). A distance of 7/16" must also be maintained for direction changes.

**WARNING: For correct installation, every piece of board (including those shorter than 20") must always be supported and fixed to the substructure in at least 3 points. This is to ensure durability over time.**

## TOOLS REQUIRED FOR INSTALLATION:

- Impact drill
- Electric screwdriver
- Electric saw
- Rubber mallet
- Various materials for tracing purpose

# LAYING METHOD 1 - SINGLE FRAME

## LAYING ON STABLE GROUND

Installation on aluminum joists involves mechanical fixing them to the ground and is suitable for installation on stable and drillable floors such as: concrete sub-bases, existing stone floors and industrial decking.

In the presence of concrete screeds laid to protect waterproofing membrane, check the actual available thickness to choose the size of the plug to fix the joists, so as not to damage the underlying membrane.

For installation in circumstances and on grounds that differ from the above, contact the Woodn Industries' technical department at the following e-mail address: [ufficiotecnico@woodn.com](mailto:ufficiotecnico@woodn.com)

## LAYING PATTERN - RUNNING BOND

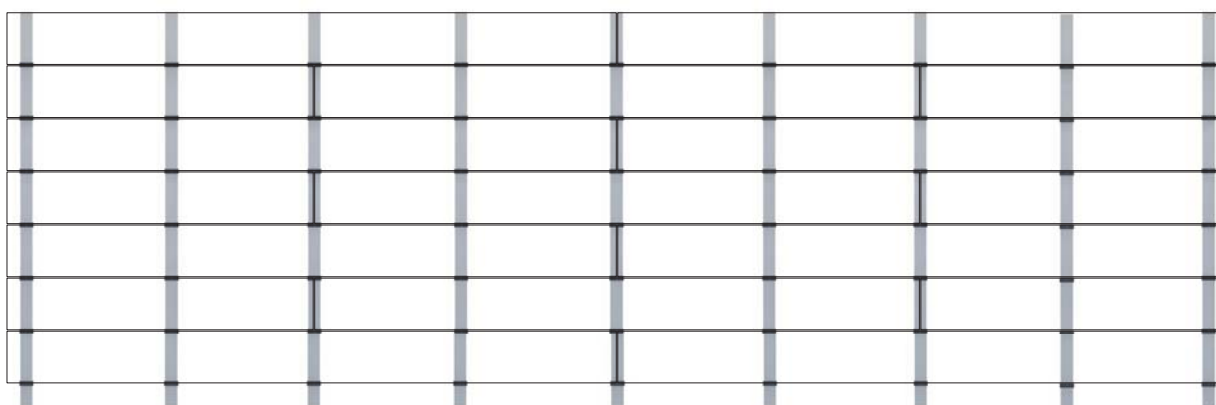

## LAYING AND FIXING OF ALUMINUM JOISTS (standard 2" 3/16 x 13/16")

Arrange the joists on the ground in a position perpendicular to the plank laying direction, with a maximum centre-to-centre distance equal to 500 mm ( $\approx 20''$ ) from each other. The positioning of the joists is closely connected to the laying surface of the planks. We recommend laying out the planks on the ground to locate the exact positions of the joists, their centre-to-centre distance may vary depending on the laying surface and the cut of the floor planks.

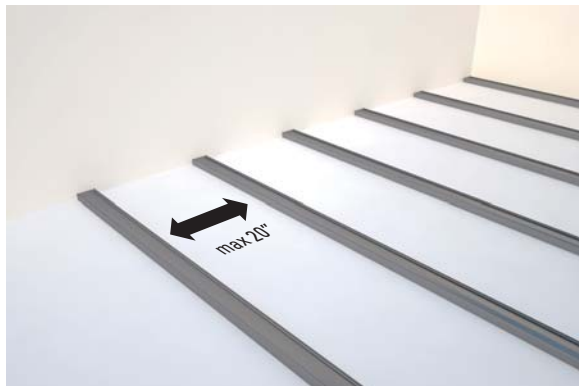

1. Arrange the joists on the ground with a maximum centre-to-centre distance of 500 mm ( $\approx 20''$ ), and take into account the floor laying pattern.



2. Drill a through hole with a diameter 1/16" to 1/8" greater than the diameter of the screw shank and another of a diameter greater than the diameter of the screw head on with the upper surface of the joist.

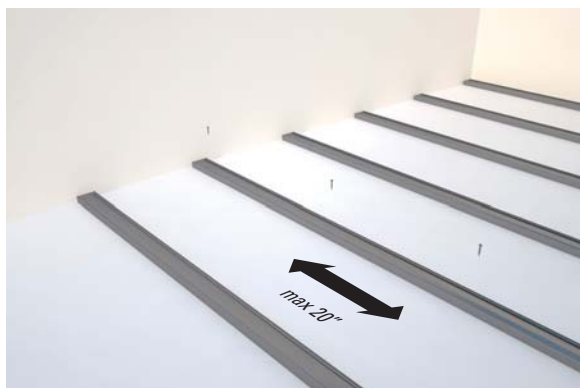

3. Attach the joists to the ground using suitable screw plugs, the centre-to-centre distance of the fixing points must not exceed 500 mm ( $\approx 20''$ ).



4. If the ground is uneven, and shimming is therefore required, ensure support to the aluminium joists at least every 500 mm ( $\approx 20''$ ).

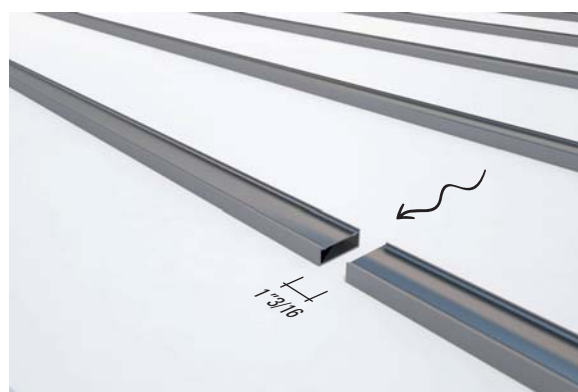
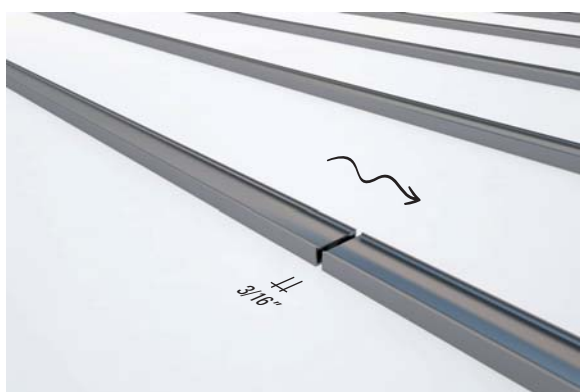

5. The distance between the ends of adjacent joists must be at least 5 mm ( $\approx 3/16''$ ) in the case of installation of the joists along the sloping side of the floor and 30 mm ( $\approx 1 3/16''$ ) in case of installation perpendicular to the slope to allow for the outflow of rainwater.

Woodn recommends to refer only to the values expressed in mm the US values are to be considered approximate).

## INSTALLATION OF THE PLANKS

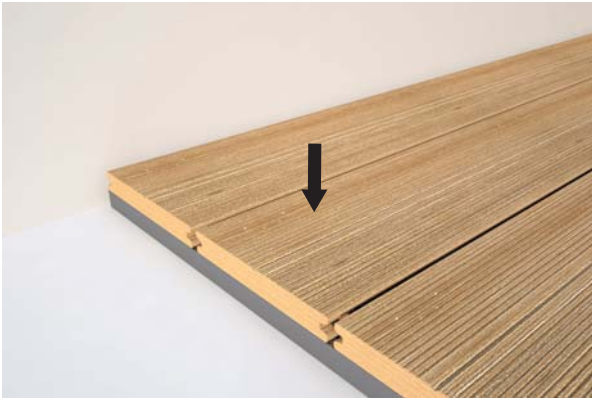

1. The brushed side must be installed facing upwards as it is treated to give it the characteristic aesthetic effect desired.



2. Apply starting clip ZCLG-AC003, by screwing it to the joist and make sure the clips are all aligned.



3. Insert the clip ZCLG-AC001 in the appropriate on the joist and fix it with self-drilling screws 3.5x19 mm.



4. Repeat the above steps until completion of the decking.

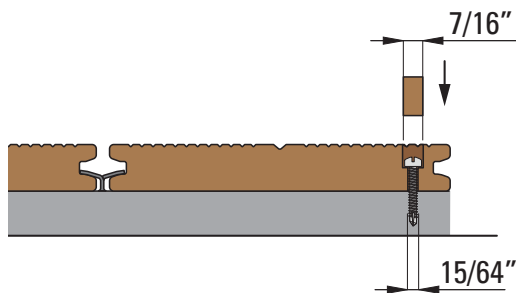

5. Where boards have to be fixed using screws, the fixing can be done with a recessed screw and the special dowel provided.

- Make a  $\varnothing 6$  mm ( $\approx 15/64$ " ) hole on the board in order to create the site for the screw 4.8x25 mm. Increasing the diameter is necessary to allow the natural movement of the board.
- Enlarge the hole in the upper 2/3 of the board to  $\varnothing 11$  mm ( $\approx 7/16$ " ).
- Fix the board to the pilot hole in the aluminium with the screw 4.8x25 mm.
- Plug the hole with the dowel and sand the surface so as to recreate the finish of the board.

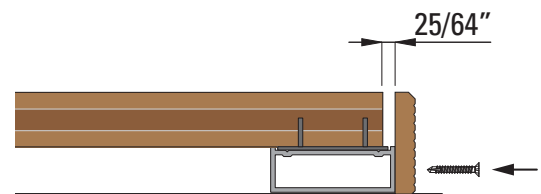

6. The edging is used to close off the ends of the boards. The fixing, with pre-hole, is made on the joist and a gap of 10 mm ( $\approx 25/64$ " ) must be left between the two items. The distance between the screws with which the edging is attached should be about 200 mm ( $\approx 7$ " 7/8 ).

# LAYING METHOD 2 - DOUBLE FRAME

## LAYING ON UNSTABLE OR ELEVATED GROUND

The laying system involves the creation of a frame consisting of aluminum joists and crosspieces and does not require fixing to the ground; it is suitable for laying on unstable or not drillable grounds such as: soil with vegetation, stabilized gravel, sand, waterproofed floors with a sheath or in general for raised floors.

For installation in circumstances and on grounds that differ from the above, contact the Woodn Industries' technical department at the following e-mail address: [ufficiotecnico@woodn.com](mailto:ufficiotecnico@woodn.com)

## LAYING PATTERN - RUNNING BOND

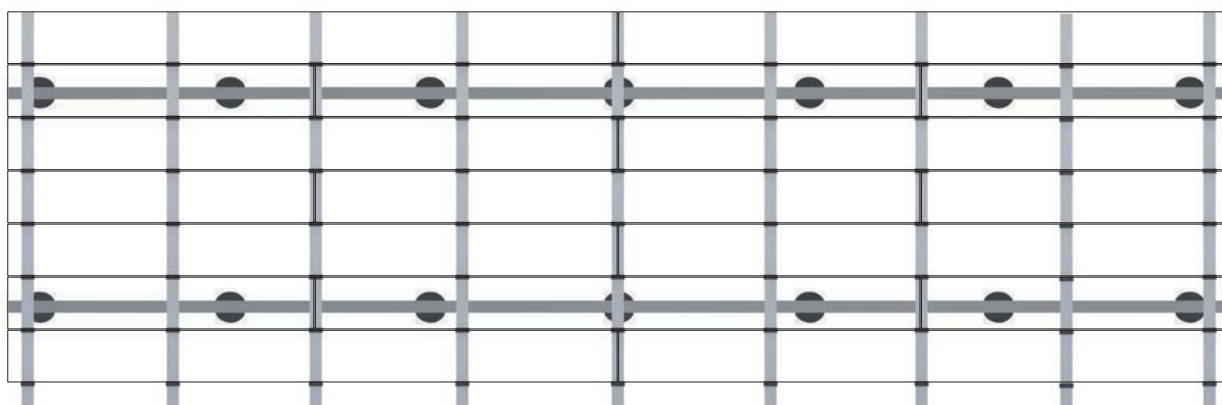

## CREATING THE ALUMINIUM FRAME and LAYING OF RAISING SUPPORTS (standard 2" 3/16 x 13/16")

Place on crosspieces and joists in accordance with the chosen laying pattern, maintaining a maximum centre-to-centre distance of 500 mm ( $\approx 20''$ ) between the joists and 500 mm ( $\approx 20''$ ) between the crosspieces. In the case of raised floors, place the supports in accordance with the laying pattern. In any case, the distance between the supports must be maximum 500 mm ( $\approx 20''$ ) in the direction parallel to the length of the planks and 500 mm ( $\approx 20''$ ) in the direction perpendicular to the length of the planks.



1. Place crosspieces and joists as shown in the figure. The joists must be firmly fixed to the crosspieces.



2. In the case of a superimposed frame, drill through holes with a  $\varnothing 5$  mm ( $\approx 3/16''$ ) on the joist and widen them to  $\varnothing 12$  mm ( $\approx 15/32''$ ) on the upper surface. Then, fix it with the self-drilling screw.



3. In the case of a coplanar frame, for a proper system rigidity the stringers should be fitted whole, interrupting the spars instead at the intersections. Common L-brackets, which can be found in any hardware store, can be used for fixing.



4. In the case of raised floors, place the supports as shown in the figure.



5. Then create the frame as indicated in the following paragraph. Mechanically fix crosspieces and joists to the supports.

Woodn recommends to refer only to the values expressed in mm the US values are to be considered approximate).

## ALUMINIUM CAPACITY (centre-to-centre distance crosspieces)

Joists	$l_{max}$
2" 3/16 x 13/16" (W x H)	500 mm (≈ 20")
2" 3/16 x 1" 3/16 (W x H)	650 mm (≈ 26")
2" 3/16 x 1" 5/8 (W x H)	800 mm (≈ 31")

## INSTALLATION OF THE PLANKS

Proceed with the installation of the planks as described in paragraph "Laying method 2".

## HEIGHT OF THE ELEVATED SYSTEM

The total height of the decking system is obtained by adding the overall size of the joist, crosspiece, plank and support. Here are the possible combinations:

Woodn™ Greendeck

Support code	Support height	Height of the finished surface*	Frame configuration
ZPSC-AC010#2235	≈ 7/8" - 1"3/8	≈ 3"5/16 - 3"13/16	Overlapped
ZPSC-AC010#3555	≈ 1"7/16 - 2"3/16	≈ 3"13/16 - 4"19/32	Overlapped
ZPSC-AC010#5595	≈ 2"3/16 - 3"3/4	≈ 4"19/32 - 6"3/16	Overlapped
ZPSC-AC010#95165	≈ 3"3/4 - 6"1/2	≈ 6"3/16 - 8"15/16	Overlapped
ZPSC-AC010#165235	≈ 6"1/2 - 9"5/16	≈ 8"15/16 - 11"11/16	Overlapped

The heights reported above are calculated considering aluminum joists and crosspieces 2" 3/16 x 13/16" (W x H)

To the ZPSC-AC010#95165 and ZPSC-AC010#165235 supports (and only to them) the extension code ZPSC-AC010#PROL can be applied, up to a maximum of 3 extensions. Each extension applied increases the height of the system by 3"15/16.











For example:

System composed of: ZPSC-AC010#95165 overlapped frame + 2 extensions finished floor height = (6"3/16 - 8"15/16) + (2 x 3"15/16) = 14"3/64 - 16"13/16 (14"3/64 minimum height, 16"13/16 maximum height).

## THEORETICAL SUPPORT INCIDENCES FOR RAISED DECKING

	stacked bond	running bond
Woodn™ Greendeck	0,46 pcs/sqft	0,46 pcs/sqft

# ACCESSORIES

accessory code	design
<p><b>Aluminum Joist</b>  <b>ZPCM-55X20-6060-T6</b>                      55 x 20 mm (W x H)                      (≈ 2"3/16 x 13/16")</p>	
<p><b>Aluminum Joist</b>  <b>ZPCM-55X30-6060-T6</b>                      55 x 30 mm (W x H)                      (≈ 2"3/16 x 1"3/16)</p>	
<p><b>Aluminum Joist</b>  <b>ZPCM-55X40-6060-T6</b>                      55 x 40 mm (W x H)                      (≈ 2"3/16 x 1"5/8)</p>	
<p><b>Stainless steel clip</b>  <b>ZCLG-AC001</b></p>	
<p><b>Stainless steel clip (starting clip)</b>  <b>ZCLG-AC003</b></p>	
<p><b>Jolly plastic clip</b>  <b>ZCLG-AC002</b></p>	
<p><b>Screw hole dowel</b>  <b>AC008</b></p>	
<p><b>Edging</b>  <b>GW007</b></p>	
<p><b>Smooth board for bullnose</b>  <b>GW001</b></p>	
<p><b>Raised floor supports</b>  <b>ZPSC-AC010#SPESS / ZPSC-AC010#H15</b>  <b>ZPSC-AC010#2235 / ZPSC-AC010#3555</b>  <b>ZPSC-AC010#5595 / ZPSC-AC010#95165</b>  <b>ZPSC-AC010#165235 / ZPSC-AC010#PROL</b></p>	

Woodn recommends to refer only to the values expressed in mm the US values are to be considered approximate).



# WOODN MODULATUS



#### DISCLAIMER - GENERAL NOTES

Due to conversion from metric sizes and measurements, the US values provided are approximate.

The information provided by WoodN Industries in this document are solely indicative, they are based on the present state of knowledge and must be considered only as a description of our products and their possible application. Such information must not be interpreted as a guarantee of specific features, performances or warranties of the product. Material's colors and finishes represented in this document are the result of printing techniques so they may slightly differ from the original colors. Original samples are available upon request and constitute only a general indication of the dimensions and the aesthetic appearance of Woodn™ profiles. WoodN Industries may change the information included in this document at any time and without further notice. WoodN Industries does not warrant the accuracy and completeness of the information in this document and furthermore their suitability for the purpose which it is consulted for by the other parties. WoodN's customers or third parties must ascertain they have the most recent version of this document, available at [www.woodn.com](http://www.woodn.com). It is advised that customers and third parties have a professional adviser to inform them about the suitability of the products for all desired applications and about applicable laws and regulations. WoodN Industries reserves the right to modify products and concerning features without prior notice. WoodN Industries is not liable for any damage arising from, or related to, the use of this document. Woodn™ material does not have structural characteristics and therefore WoodN Industries declines all responsibilities for improper use of the material. No sections of this publication can be reproduced, stored in database, or transmitted in any form or by any other mean without the explicit approval of WoodN Industries. For more information please contact WoodN Industries.

# MATERIAL'S FEATURES

## Mechanical properties

Elasticity (bending)	UNI EN ISO 178	@73 °F @149 °F
Yield strenght (flexural)	UNI EN ISO 178	@73 °F @149 °F
Water absorbption and humidity	ASTM D1037	absorption 0,07%
Dynamic- Mechanical analysis of transition temperature	ASTM D4065/95	173.8 °F
Linear thermal expansion coefficient (from 14 °F to 158 °F)	TMA ASTM E 831/2006	longitudinal $46,9 \times 10^{-6} \text{ m}/(\text{m}^{\circ}\text{C})$ trasversal $48 \times 10^{-6} \text{ m}/(\text{m}^{\circ}\text{C})$
Tensile strenght and tensile strenght after accelerated weathering (exposure to xenon lights)	ASTM D638-10 (tensile test) ASTM G155-050	difference after 2 months of exposure ~5,21% difference after 3 months of exposure ~6,9% (meet the requirements to comply with Miami Dade and Florida Building Code 2014)

## Reaction to fire

Flammability	UL94 AS 3959-2009	V-0 Class BAL-29
Flame spread index Smoke developed index	ASTM E84	Class A
Ignition temperature	ASTM D1929	890 °F
Average critical radiant flux of floor	AS ISO 9239 ASTM E648	$\geq 11 \text{ kW}/\text{m}^2$ $> 1,03 \text{ W}/\text{cm}^2$ (class I as per NFPA 101)
Ignitability, flame propagation, heat release and smoke release	AS/NZS 1530.3:1999	Ignitability (0-20) = 8 Spread of Flame (0-10) = 0 Heat Evolved (0-10) = 0 Smoke Developed (0-10) = 7

## Chemical and biological features

Evaluation of the action of microorganisms (scale from 0 to 5)	EN ISO 846:97	Test result: 1
Heavy metal content (Pb, Ge, Cr, Hg)	GB18584-2001 GB18580-2001	< 0,5 ppm
Formaldehyde emission	EN 717-2:1994	0,1 mg HCHO/(m <sup>2</sup> h)



The values shown are indicative and not binding. Test reports available upon request.  
The natural aging of the material and temperature variations may cause deviations from the values indicated above.  
The product is protected by a warranty in line with legal requirements: for more information see the SPECS on [www.woodn.com](http://www.woodn.com)

# GENERAL INSTALLATION INSTRUCTIONS

Key points to be followed before and during the installation process:

- Store the material on a flat surface providing for a stable support on the whole surface, in a dry, clean area, protected from frost and direct sun light.
- Before starting the installation, carefully check the material and notify immediately of any manufacturing issues. Complaints will not be accepted after installation.
- Before starting the installation, check project's drawings (or shop drawings if provided) and the correspondence of the received material against the packing list.
- Acclimate the material in stock to the temperature of the jobsite for at least 48 hours prior to installation.
- The installation temperature must be higher than 32 °F.
- Do not cover the product with sheets made with non-breathable material (nylon, polyethylene and similar materials). For this purpose it is advisable to use breathable material such as painter felt sheets.
- The accumulation of electrostatic charges is a natural phenomenon commonly found in plastic materials, and under exceptional environmental conditions this may also occur in Woodn™'s products.
- Profiles shall be handled with care in order to prevent damages. It is recommended to lift the profiles on the whole length during displacement and not make them slide on top of each other. Always use clean fabric gloves when handling profiles.
- Prevent the formation of dirt on and between profiles; in particular, make sure that mechanical processes carried out on other materials, near Woodn products, do not determine the accumulation of chips or dust of any kinds. During the installation/assembly phase do not apply any label or sticker; if already applied, please remove immediately after installation. Immediately remove major stains such as paint, concrete or tar residues.
- For cleaning and maintenance instructions refer to page 115. The WoodN warranty will be rendered null and void in the event of incorrect or improper handling, cleaning and maintenance.

## EXPANSION GAP BETWEEN ADJACENT PROFILES AND WALLS

WoodN, due to material's composition's features and extrusion technology, undergoes after the first exposure an initial dimensional shrinkage less than 0.4% of the profile length (max value established according to EN 479: 1995) and presents a linear contraction / dilatation due to temperature variations. In outdoor applications, leave a gap at the end of the profile according to the relative size in the table below:

Laying temperature	Expansion gap [in/ft]
< 68 °F	1/40" (2 mm/m)
> 68 °F	1/80" (1 mm/m)

For example:

*For laying conditions with a temperature around 86 °F and a plank length of 6', it should be left gaps measuring 6' x 1/80" in/ft = 5/64".*

**WARNING: it has to be noted that the failure to comply strictly with the criteria for the application of fixed points and floating points, causes the deformation of the materials and the misalignment of all the expansion joints.**

Woodn recommends to refer only to the values expressed in mm the US values are to be considered approximate).

## FIXED POINT

To make sure that the expansion gap will remain over time, in outdoor applications a FIXED POINT should be made on each plank. We also recommend strictly adhering to the positioning pattern of the fixed point.

## LAYING PATTERN - RUNNING BOND

● = fixed point for expansion

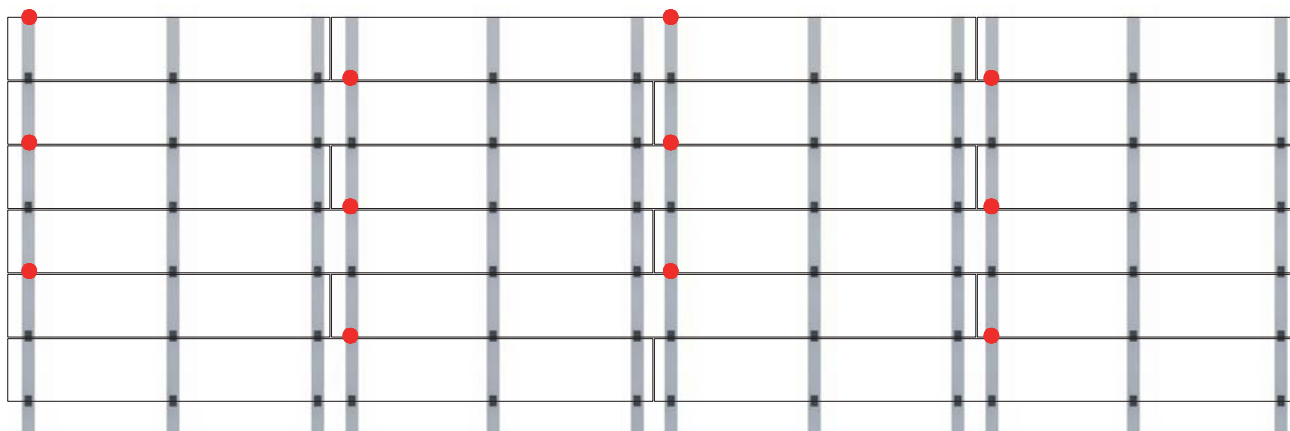

## ALIGNMENTS











We recommend to align and plumb the substructure before you starting the installation. We recommend leaving an expansion joint between the heads of the substructure profiles in correspondence with the floors slabs for possible settling of the building.



In correspondence of the heads of two consecutive planks, the aluminum joists must be doubled as shown in the photo.

# PROFILES SECTION

## outdoor cladding

profile	cross-section	nominal dimensions [ft, in]	weight of the plank [lb/ft]
<b>Q9510</b> 		section 95 x 10 mm (≈ 3"3/4 x 7/16") standard length 1830 mm (≈ 6')	0.40
<b>Q13010HD</b> 		section 130 x 10 mm (≈ 5"1/8 x 7/16") standard length 1830 mm (≈ 6')	0.79
<b>Q20410</b> 		section 204 x 10 mm (≈ 8"1/16 x 7/16") standard length 1830 mm (≈ 6')	1.56
<b>TH14830HD-4</b> 		section 148 x 30 mm (≈ 5"13/16 x 1"3/16) standard length 1830 mm (≈ 6')	0.69
<b>TH6050HD</b> 		section 54 x 60 mm (≈ 2"3/16 x 2"3/8) standard length 1830 mm (≈ 6')	0.54

Woodn recommends to refer only to the values expressed in mm the US values are to be considered approximate).

The external dimensions listed are nominal values.  
 The weights of the planks indicated in the tables are indicative and not binding.  
 Length tolerances according UNI EN-ISO 22768: class UNI EN-ISO 22768-vL.

# Q9510 - outdoor cladding

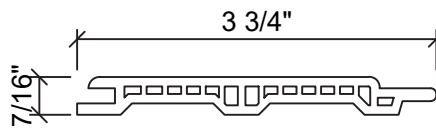

Woodn recommends to refer only to the values expressed in mm the US values are to be considered approximate).



## MOUNTING SYSTEM

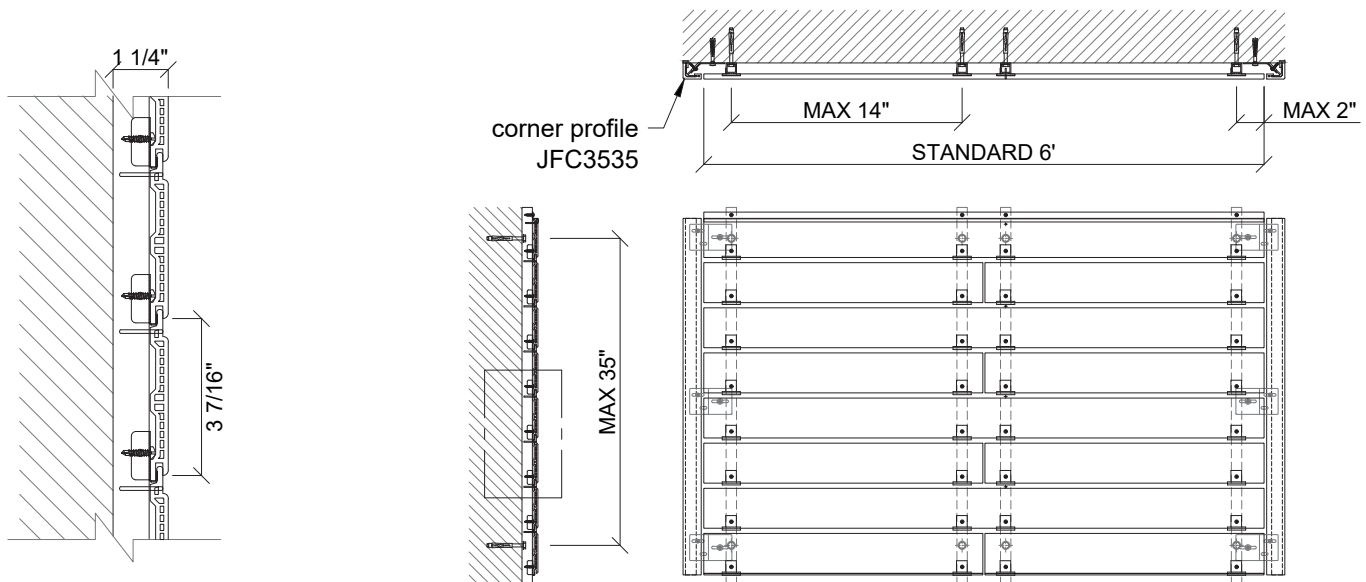

WEIGHT OF THE SYSTEM  $\approx$  1.74 lb/sqft  
 WEIGHT OF THE SYSTEM (without substructure)  $\approx$  1.46 lb/sqft  
 • Dimensions considering a standard wind load of 24.59 pound/sqft

# ASSEMBLY INSTRUCTIONS



1. Screw the aluminum joist profiles to support with suitable screws and wall plugs (\*).



2. Apply the first row of ZCLW-KK2826 clips at the bottom with self-drilling screws.



3. Fit the plank in the respective clip slot.



4. Insert the second row of clips to lock the plank.

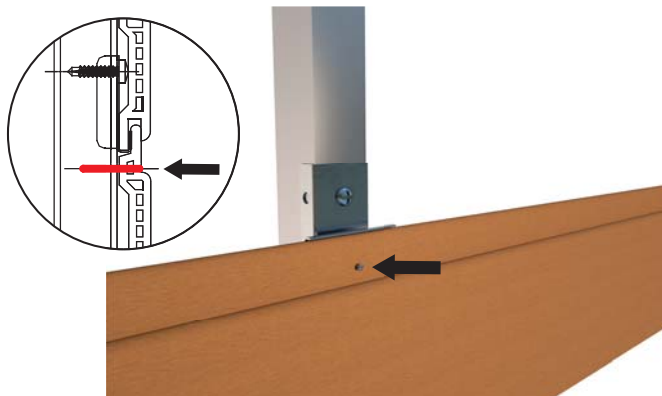

5. Install a cylindrical pin ZCPW-D2X24-A2 for the fixed point (make a pre-hole  $\varnothing \approx 1/16''$ ).



6. Repeat as described from step 3 up to the top to complete the cladding.

\*Screws and wall plugs must be chosen according to the type of wall support

# DETAILS FOR CORNERS



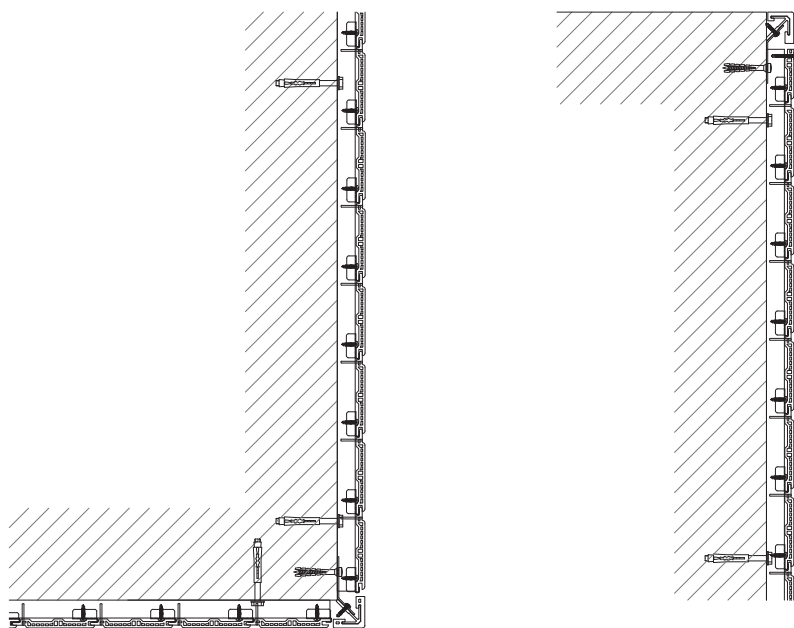

## VERTICAL PLANKS

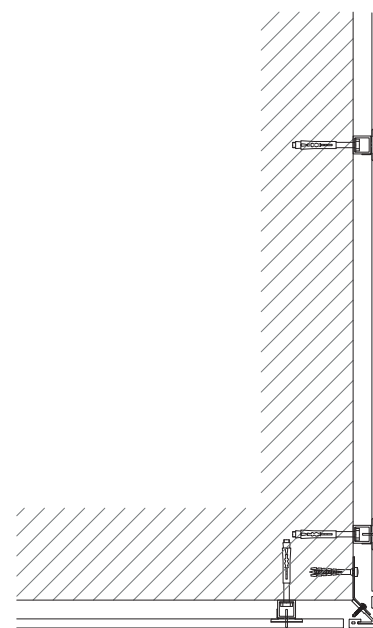



## HORIZONTAL PLANKS



## SYSTEM COMPONENTS

Profile <b>Q9510</b>		3.51 ft/sqft	Substructure profile <b>ZTQM-20X20X2-6060-T6</b>		1.04 ft/sqft (stacked bond) 1.19 ft/sqft (running bond)
Fixing clip <b>ZCLW-KK2826</b>		3.72 pcs/sqft (stacked bond) 4.18 pcs/sqft (running bond)	Screw <b>ZRHW-3.5X16-A2-7504N</b>		3.72 pcs/sqft (stacked bond) 4.18 pcs/sqft (running bond)
Dowel pin <b>ZCPW-D2X24-A2</b>		0.55 pcs/sqft			

## CORNERS COMPONENTS

Profile <b>JFC3535</b>		Fixing bracket <b>ZCLW-WAJFC3535_6050</b>		Screw <b>ZRHW-3.5X16-A2-7504N</b>	
---------------------------	---	--	--	--------------------------------------	---

**WARNING:** the incidences of accessory material indicated refer to application according to the European standards, which provides for planks 6' long and slats/substructure with maximum distance o.c. up to 14". For any installation that differs from the standard a cutting plan must be designed; it shall calculate precisely the number of points of intersection between the planks and the substructure, allowing the correct identification of the number of clips and screws required for each type of application.

# Q13010HD - outdoor cladding

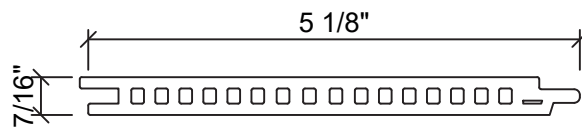

Woodn recommends to refer only to the values expressed in mm (the US values are to be considered approximate).



## MOUNTING SYSTEM

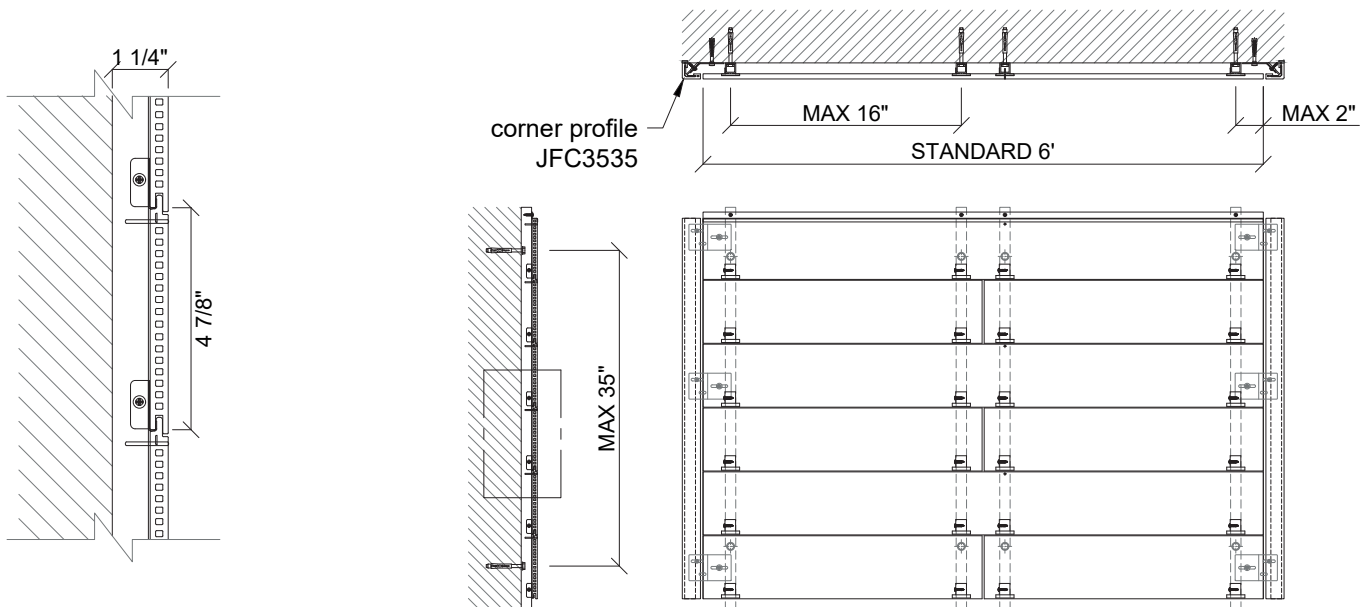

WEIGHT OF THE SYSTEM ≈ 2.25 lb/sqft  
 WEIGHT OF THE SYSTEM (without substructure) ≈ 2.01 lb/sqft  
 • Dimensions considering a standard wind load of 24.59 pound/sqft

# ASSEMBLY INSTRUCTIONS



1. Screw the aluminum joist profiles to support with suitable screws and wall plugs (\*).



2. Apply the first row of ZCLW-KK2826 clips at the bottom with self-drilling screws.

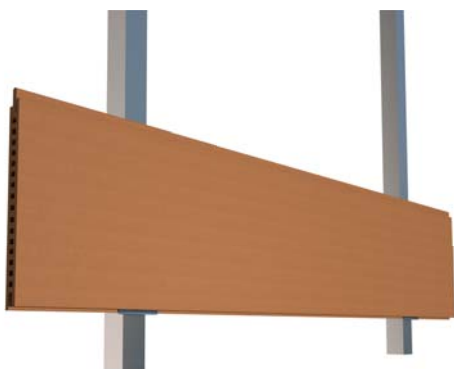

3. Fit the plank in the respective clip slot.



4. Insert the second row of clips to lock the plank.

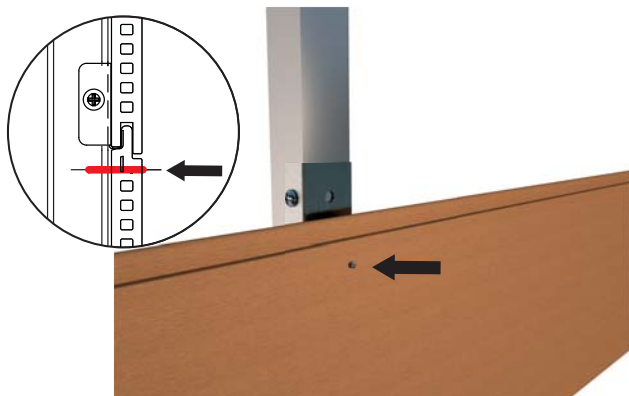

5. Install a cylindrical pin ZCPW-D2X24-A2 for the fixed point (make a pre-hole  $\varnothing \approx 1/16''$ ).



6. Repeat as described from step 3 up to the top to complete the cladding.

\*Screws and wall plugs must be chosen according to the type of wall support

# DETAILS FOR CORNERS



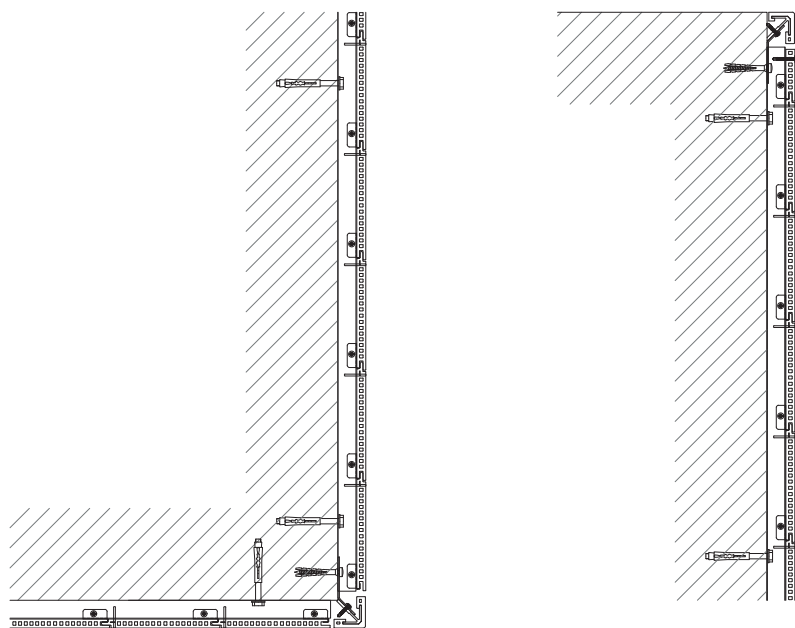

## VERTICAL PLANKS

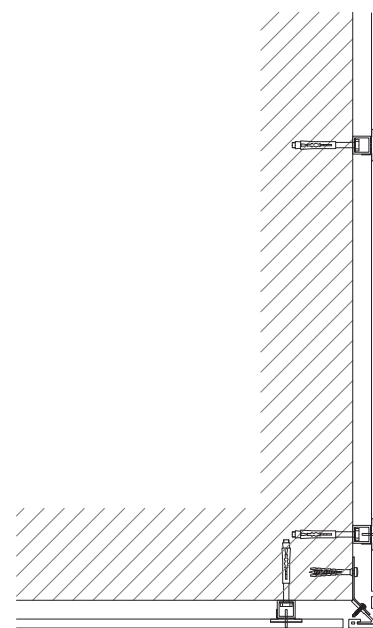



## HORIZONTAL PLANKS



## SYSTEM COMPONENTS

Profile <b>Q13010HD</b>		2.50 ft/sqft	Substructure profile <b>ZTQM-20X20X2-6060-T6</b>		0.92 ft/sqft (stacked bond) 1.07 ft/sqft (running bond)
Fixing clip <b>ZCLW-KK2826</b>		2.32 pcs/sqft (stacked bond) 2.69 pcs/sqft (running bond)	Screw <b>ZRHW-3.5X16-A2-7504N</b>		2.32 pcs/sqft (stacked bond) 2.69 pcs/sqft (running bond)
Dowel pin <b>ZCPW-D2X24-A2</b>		0.46 pcs/sqft			

## CORNERS COMPONENTS

Profile <b>JFC3535</b>		Fixing bracket <b>ZCLW-WAJFC3535_6050</b>		Screw <b>ZRHW-3.5X16-A2-7504N</b>	
---------------------------	---	--	--	--------------------------------------	---

**WARNING:** the incidences of accessory material indicated refer to application according to the European standards, which provides for planks 6' long and slats/substructure with maximum distance o.c. up to 16". For any installation that differs from the standard a cutting plan must be designed; it shall calculate precisely the number of points of intersection between the planks and the substructure, allowing the correct identification of the number of clips and screws required for each type of application.

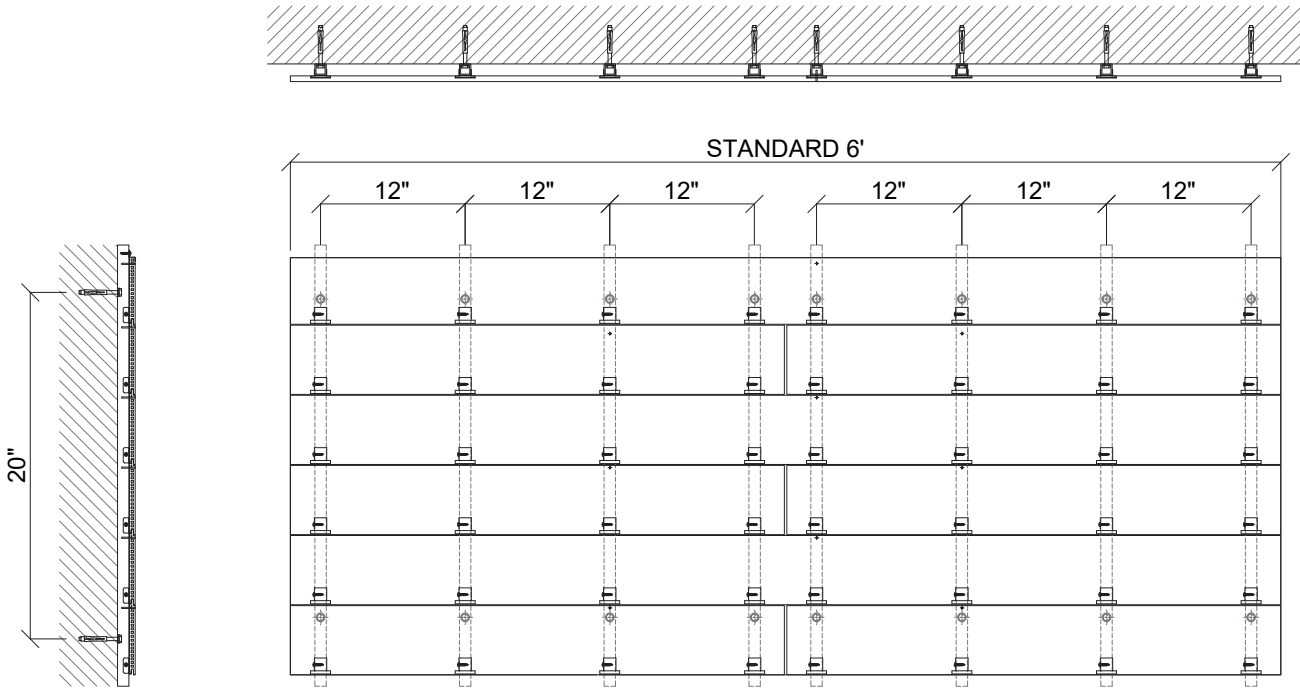

7341 Westport Pl Suite 1A, West Palm Beach, FL 33413  
 Phone: 561-506-2390 E-mail: Eng@p@blackwater-testing.com  
 REPORT NO: BT-FCS-16-003 MIAMI-DADE CERTIFICATION #15-1026-02  
 Test Dates: 07/07/2016 to 07/08/2016

**TESTING FOR UNIFORM STATIC AIR PRESSURE  
 TAS 202-94 POSITIVE AND NEGATIVE CYCLIC  
 LOADS TAS 203-94 OF "Q13010HD WOODN PANEL"**

**Client:**  
**WOODN INDUSTRIES SRL.**  
 Via Ippolito Caffi, 17  
 32 00 Belluno (BL), Italy  
 Office Phone: (+39) 049 89 60.706

**Product Description of Unit:** Sp. 1-2-3 Q.13010HD WOODN PROFILE with Aluminum Hat Channel Backing  
 Sp. 4-5-6 Q.13010HD WOODN PROFILE with Aluminum Tube Backing

**Overall Size:** Sp 1-2-3 41 1/2"X44"-T2  
 Sp 4-5-6 42 3/4"X44 1/2"

**Test Buck Size:** Sp 1-2-3 41-1/2"X44"  
 Sp 4-5-6 42-3/4"X44 1/2"

**Test Protocol:** Sp 1-2-3 TAS 202-94@+/-150psfDP---TAS 203-94@+/-150psfDP  
 Sp 4-5-6 TAS 202-94@+/-150psfDP---TAS 203-94@+/-150psfDP

**Disclaimer:**  
 This is a general statement and does not supersede the specific product descriptions in this report. The specimens are in conformance with attached Drawings. These drawings have been marked to indicate the appropriate portions descriptive of this test series. Blackwater Testing Inc. does not take responsibility of product performance and whose only purpose is to test and gather pertinent data under test report format for the client.

**Witness to Testing:**  
 Dennis Duffy, BT CED  
 Erik Coppola, BT Lab Technician  
 Constantin Bortes, PE, Test Engineer

7-13-2016

Reports pertaining to the samples tested only and may not be reproduced without permission. Copyright 2016  
 BT-FCS-16-003 7/15/2016 Page 1

# Q20410 - outdoor cladding

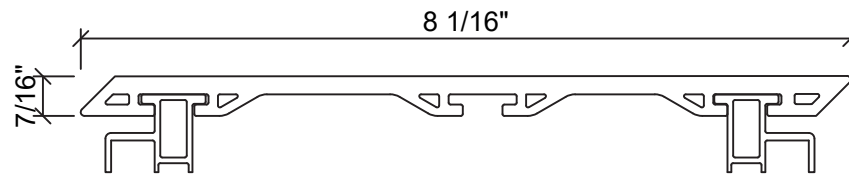

Woodn recommends to refer only to the values expressed in mm the US values are to be considered approximate).



## MOUNTING SYSTEM

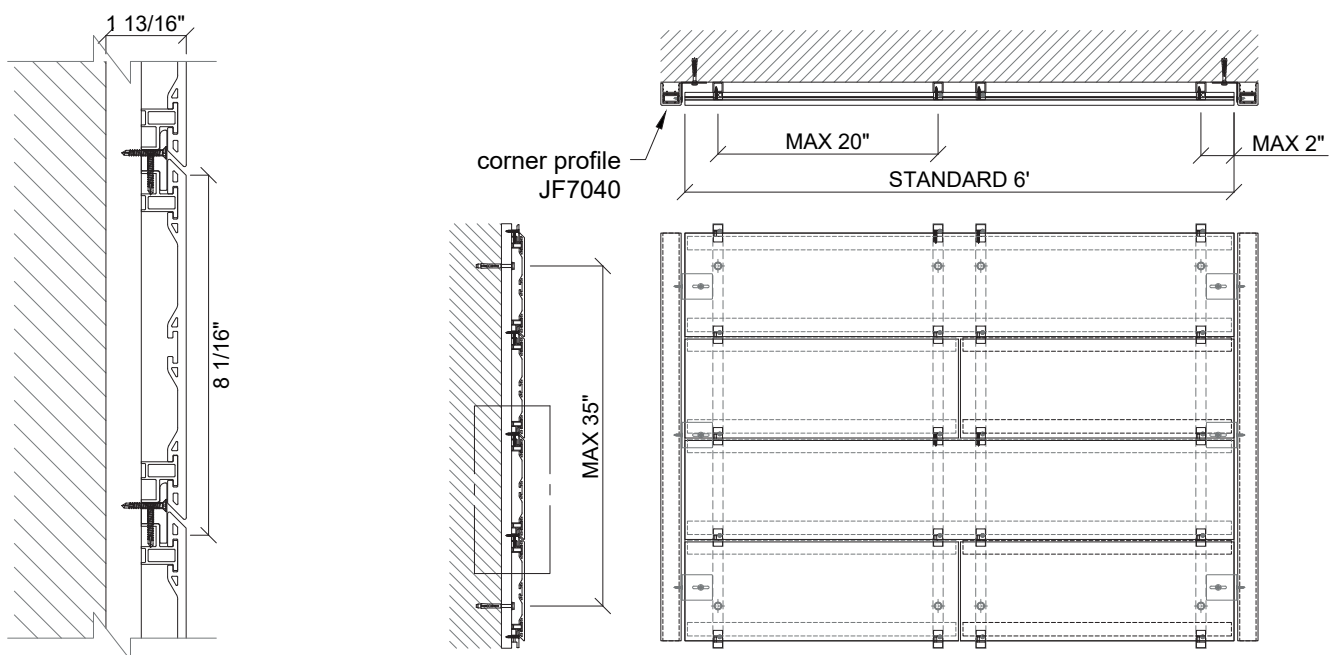

WEIGHT OF THE SYSTEM  $\approx 3.40$  lb/sqft  
 WEIGHT OF THE SYSTEM (without substructure)  $\approx 3.20$  lb/sqft  
 • Dimensions considering a standard wind load of 24.59 pound/sqft

# ASSEMBLY INSTRUCTIONS



1. Screw the aluminum joist profiles to support with suitable screws and wall plugs (\*).



2. Apply the first row of ZCLW-KK3418 clips at the bottom with self-drilling screws.

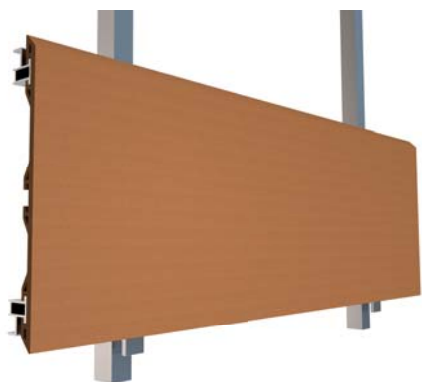

3. Insert the first plank into the respective clip slot matching the aluminium reinforcements at the back.



4. Insert the second row of clips to lock the plank.

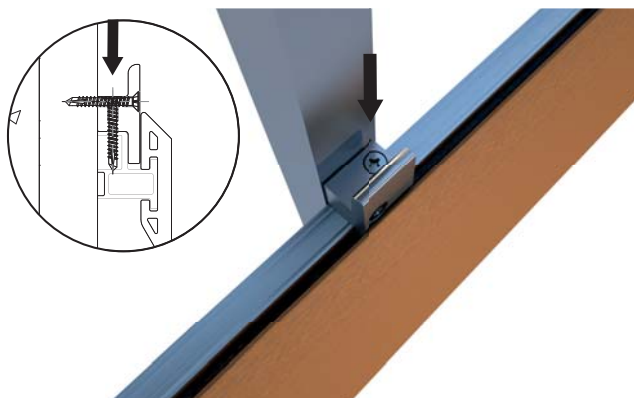

5. Install the screw to form the fixed point (make a pilot hole to make the step easier). Only apply 1 fixed point for each plank.



6. Repeat as described from step 3 up to the top to complete the cladding.

\*Screws and wall plugs must be chosen according to the type of wall support.

## ALTRNATIVE - STARTING WITH "Z" PROFILE



1. Screw the aluminum joist profiles to support with suitable screws and wall plugs (\*).

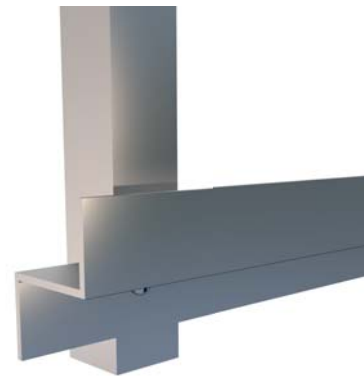

2. Install the Z starting profile in the lower part using self drilling screws. Continue with points 3 to 6 of the previous page.

## CUTTING THE PROFILES



1. Remove the screws from the fixed points.

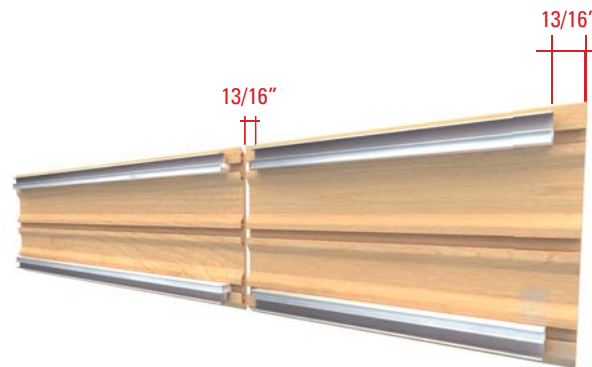

2. Cut the profiles to the required length. The aluminum profiles must be cut 40 mm ( $\approx 1\frac{9}{16}$ ) shorter than the Woodn profile.



3. Insert the screws into the fixed points (ZRHW-3.5X13-A2-7504N).

NOTE: on each profile Q20410-WA 2 fixed point screws must be applied.

# DETAILS FOR CORNERS



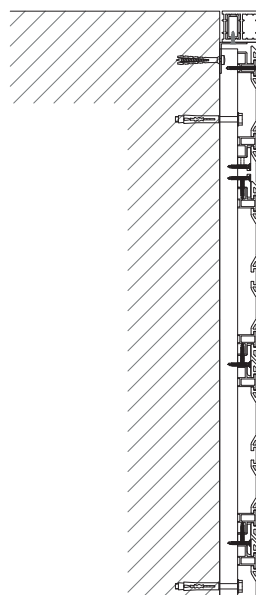
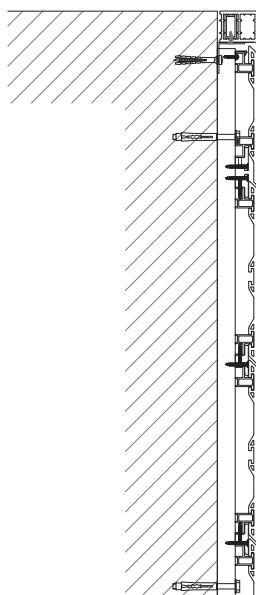
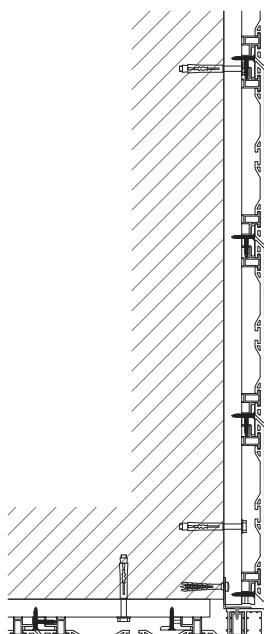

## VERTICAL PLANKS

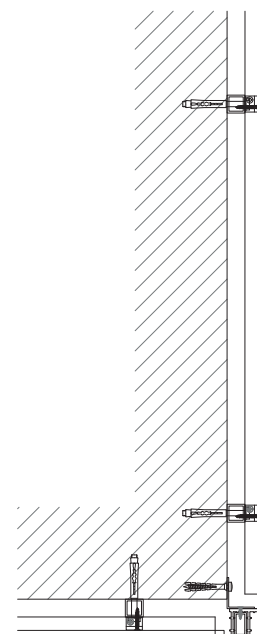

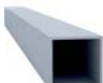

## HORIZONTAL PLANKS



## SYSTEM COMPONENTS

Profile <b>Q20410</b>		1.52 ft/sqft	Substructure profile <b>ZTQM-20X20X2-6060-T6</b>		0.76 ft/sqft (stacked bond) 0.91 ft/sqft (running bond)
Fixing clip <b>ZCLW-KK3418</b> (Alloy ZAMAK 3)		1.20 pcs/sqft (stacked bond) 1.40 pcs/sqft (running bond)	Screw <b>ZFHC-3.5X25-A2-7504P</b>		1.48 pcs/sqft (stacked bond) 1.68 pcs/sqft (running bond)
Fixing clip <b>ZCLW-KK1515</b>		available upon request	Z starting profile <b>ZTQW-10X10X13X1.5-6060-T6</b>		available upon request

## CORNERS COMPONENTS

Profile <b>JF7040-30x15</b>		Fixing bracket <b>ZCLW-WAQ20410_6040</b>		Screw <b>ZRHW-3.5X16-A2-7504N</b>	
--------------------------------	---	---	--	--------------------------------------	---

WARNING: the incidences of accessory material indicated refer to application according to the European standards, which provides for planks 6' long and slats/substructure with maximum distance o.c. up to 20". For any installation that differs from the standard a cutting plan must be designed; it shall calculate precisely the number of points of intersection between the planks and the substructure, allowing the correct identification of the number of clips and screws required for each type of application.



# Q20410 - NFPA 285

## FIREBREAK PROFILE

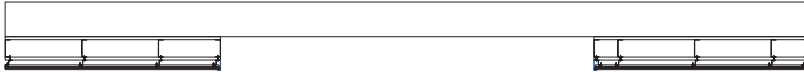
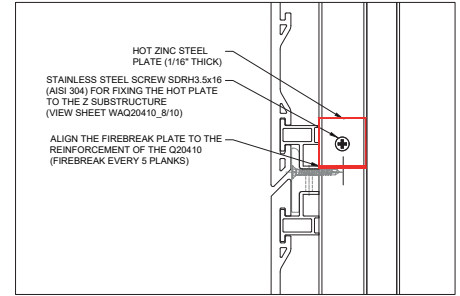
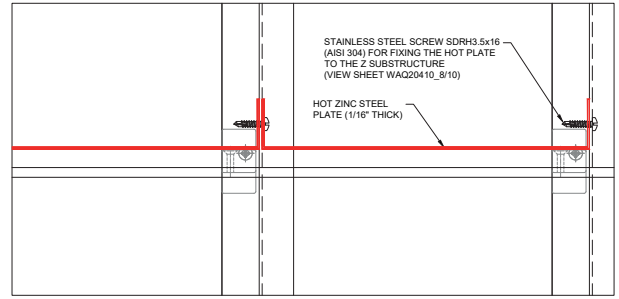

HORIZONTAL SECTION D  
Scale 1:10

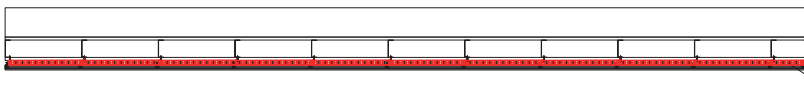

HORIZONTAL SECTION C  
Scale 1:10

INTERNAL CLADDING: AMERICAN GYPSUM TYPE X GYPSUM BOARD  
20GA STEEL GAUGE @16"  
EXTERNAL CLADDING: DENSGLASS GOLD EXTERIOR SHEATHING (GEORGIA PACIFIC)  
HOT ZINC STEEL PLATE (1/16" THICK)

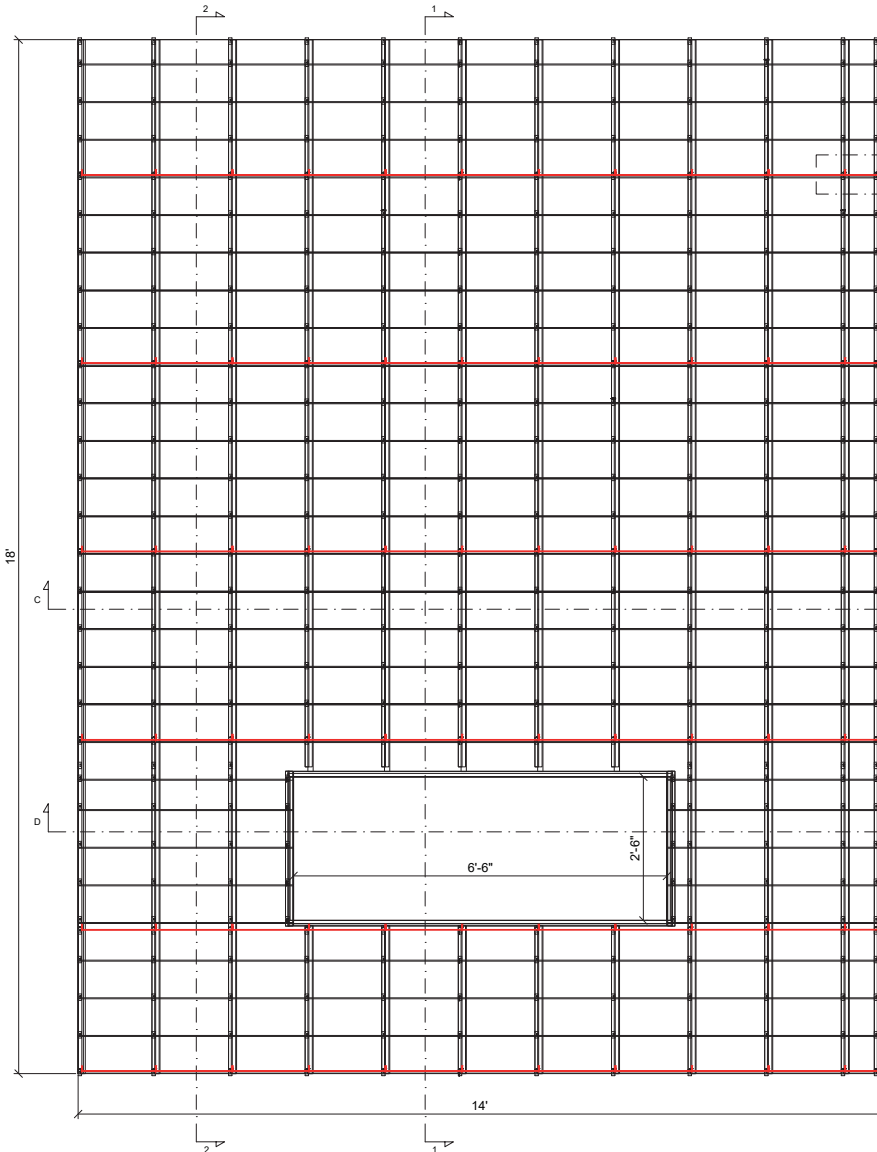

VERTICAL SECTION 1  
Scale 1:10

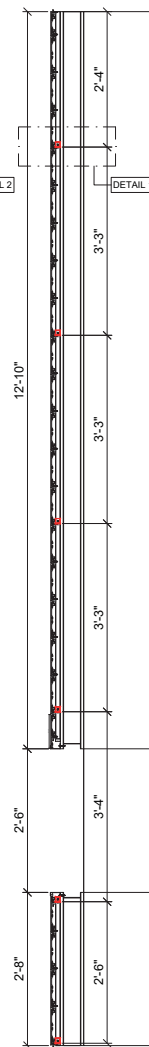

VERTICAL SECTION 2  
Scale 1:10

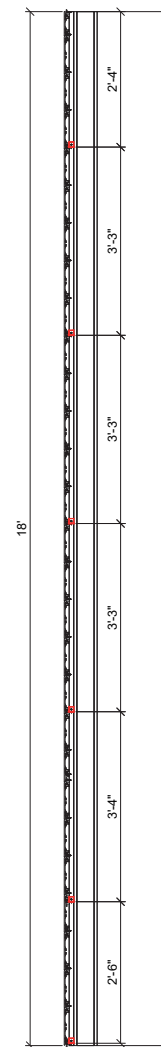

# Q20410 - WOODN NOA #17-1016.30

**MIAMI-DADE COUNTY  
APPROVED**

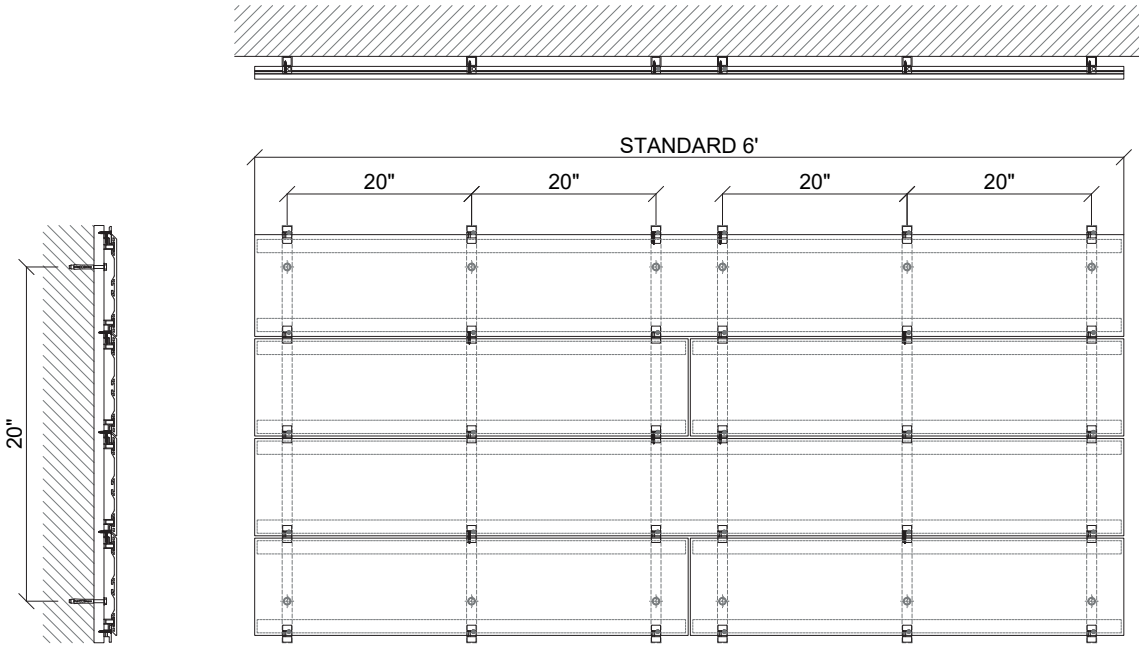

**TESTING FOR UNIFORM STATIC AIR PRESSURE  
TAS 202-94 POSITIVE AND NEGATIVE CYCLIC  
LOADS TAS 203-94 OF "Q20410 WOODN PROFILE"**

**WOOD INDUSTRIES SRL**  
Via Spicchi Carr. 17  
32100 Belluno (BL), Italy  
Office Phone: (+39) 043 85 80 705

Specimen 1-2-3    Specimen 4-5-6

**Product Description of Unit:** Sp 1-2-3 Q20410 WOODN PROFILE with Aluminum Hat Channel Backing  
Sp 4-5-6 Q20410 WOODN PROFILE with Aluminum Tube Backing

**Overall Size:** Sp 1-2-3 48 1/2" x 20"  
Sp 4-5-6 48 1/2" x 20 3/4"

**Test Back Size:** Sp 1-2-3 48 1/2" x 12"  
Sp 4-5-6 48 1/2" x 12"

**Test Protocol:** Sp 1-2-3 TAS 202-94(+)10qwDP - TAS 203-94(+)10qwDP  
Sp 4-5-6 TAS 202-94(-)10qwDP - TAS 203-94(-)10qwDP

**Disclaimer:** This is a general statement and does not represent the specific product description in this report. The specimens are in conformance with attached Drawings. These drawings have been reviewed to indicate the appropriate portions description of the test setup. Specimen Testing Inc. does not take responsibility of product performance and whose only purpose is to test and gather pertinent data under test report format for the client.

**Witness to Testing:**  
Dennis Duffy, BT CEO  
Eva Corvino, BT Lab Technician  
Yehid G. Kur, P.E. Test Engineer

APR 12 2018

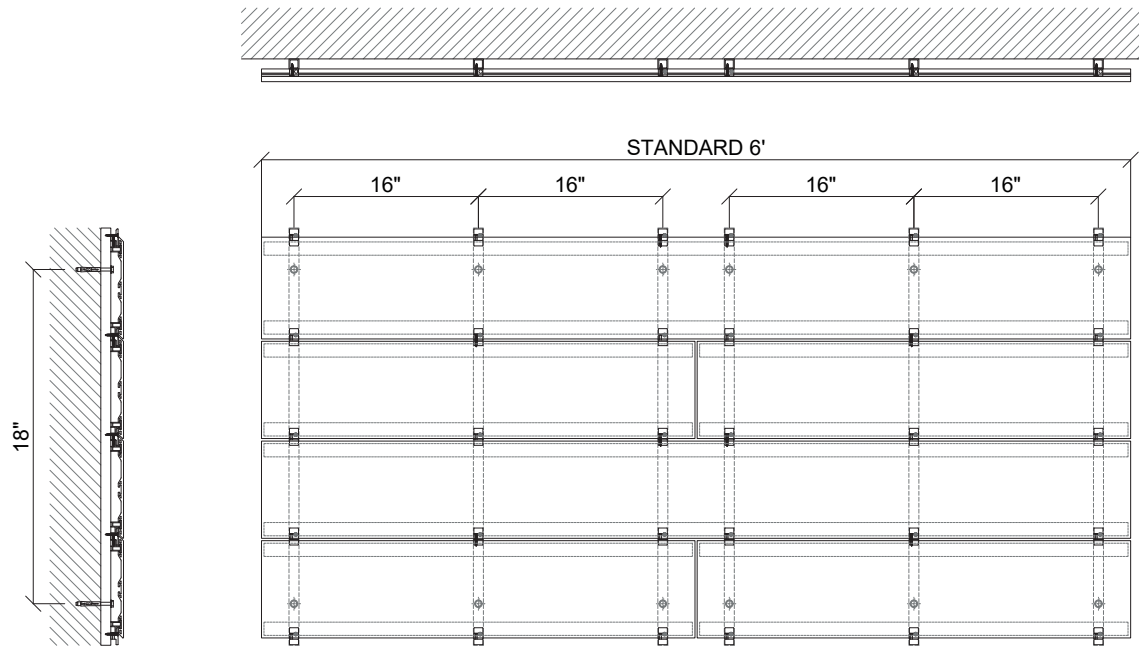

**TESTING FOR UNIFORM STATIC AIR PRESSURE  
TAS 202-94 POSITIVE AND NEGATIVE CYCLIC  
LOADS TAS 203-94 OF "Q20410 WOODN PROFILE"**

**WOOD INDUSTRIES SRL**  
Via Spicchi Carr. 17  
32100 Belluno (BL), Italy  
Office Phone: (+39) 043 85 80 705

Specimen 1-2-3    Specimen 4-5-6

**Product Description of Unit:** Sp 1-2-3 Q20410 WOODN PROFILE with Aluminum Hat Channel Backing  
Sp 4-5-6 Q20410 WOODN PROFILE with Aluminum Tube Backing

**Overall Size:** Sp 1-2-3 51 1/2" x 16"  
Sp 4-5-6 48 3/4" x 16"

**Test Back Size:** Sp 1-2-3 51 1/2" x 8"  
Sp 4-5-6 48 3/4" x 8"

**Test Protocol:** Sp 1-2-3 TAS 202-94(+)10qwDP - TAS 203-94(+)10qwDP  
Sp 4-5-6 TAS 202-94(-)10qwDP - TAS 203-94(-)10qwDP

**Disclaimer:** This is a general statement and does not represent the specific product description in this report. The specimens are in conformance with attached Drawings. These drawings have been reviewed to indicate the appropriate portions description of the test setup. Specimen Testing Inc. does not take responsibility of product performance and whose only purpose is to test and gather pertinent data under test report format for the client.

**Witness to Testing:**  
Dennis Duffy, BT CEO  
Eva Corvino, BT Lab Technician  
Yehid G. Kur, P.E. Test Engineer

APR 12 2018

# TH14830HD-4 - outdoor cladding

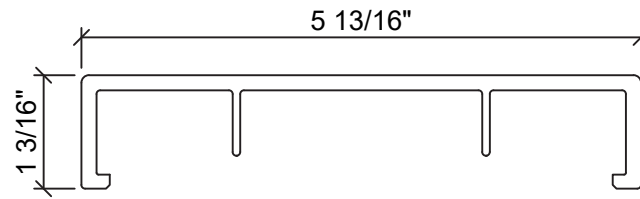

Woodn recommends to refer only to the values expressed in mm the US values are to be considered approximate).



## MOUNTING SYSTEM

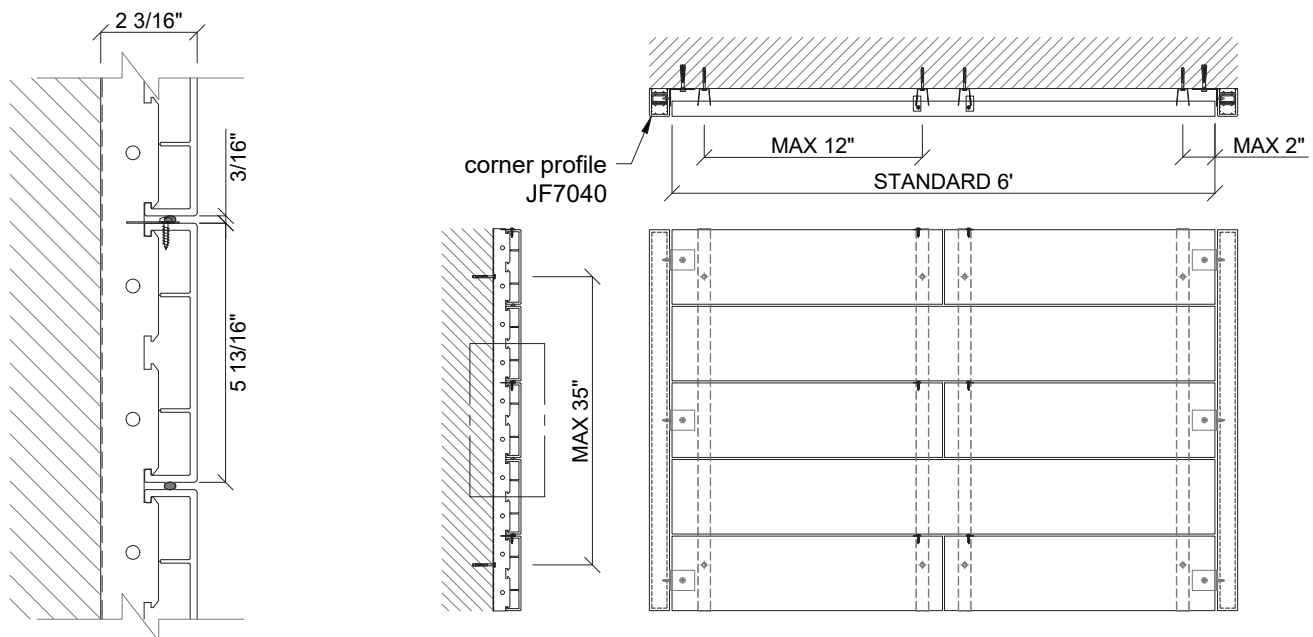

WEIGHT OF THE SYSTEM ≈ 1.97 lb/sqft  
 • Dimensions considering a standard wind load of 24.59 pound/sqft

# ASSEMBLY INSTRUCTIONS



1. Screw the ZSSW-LG3326V profiles to support with suitable screws and wall plugs (\*).



2. Install the first TH14830HD-4 profile.



3. Apply the clip for the FIXED POINT with self-drilling screws to the profile.

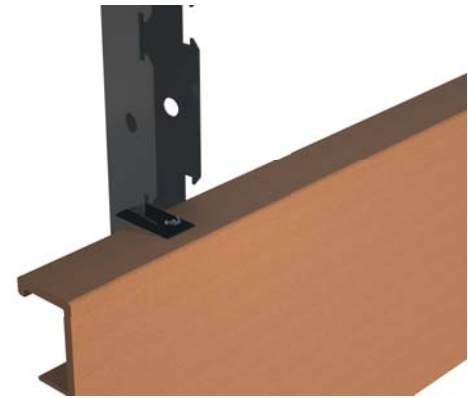

4. NOTE: the clip has to slot in the substructure.



5. Repeat as described from step 2 up to the top to complete the cladding.

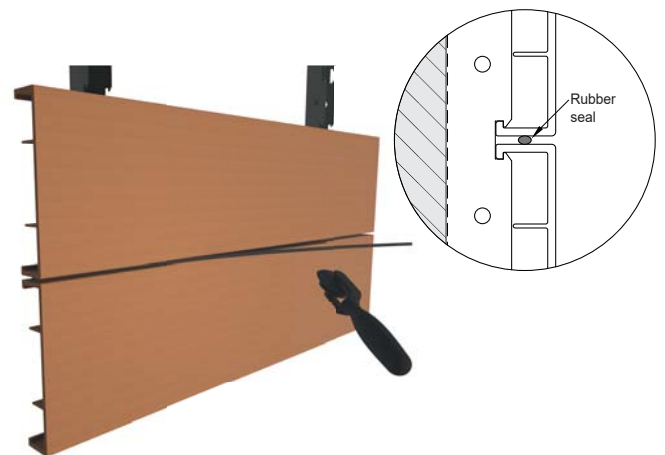

6. Insert the rubber seal into the joint using the supplied tool.

\*Screws and wall plugs must be chosen according to the type of wall support.





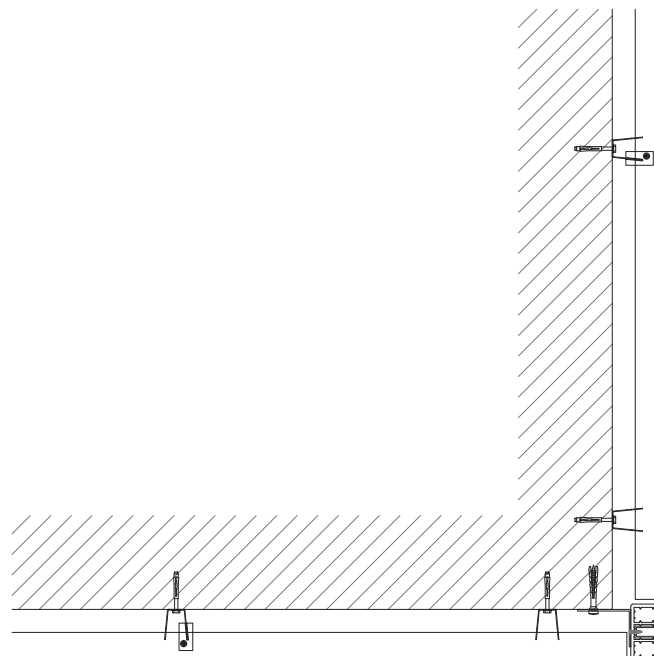
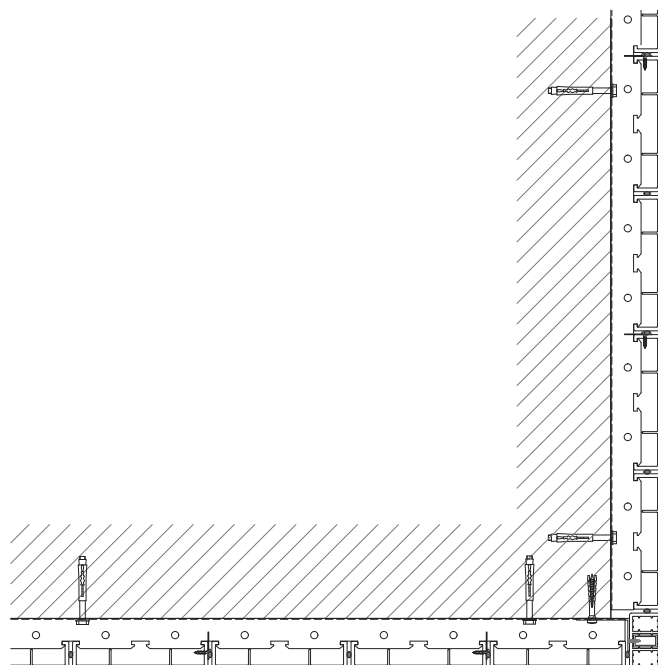

# DETAILS FOR CORNERS

## VERTICAL PLANKS

## HORIZONTAL PLANKS



## SYSTEM COMPONENTS

Profile <b>TH14830HD-4</b>		2.01 ft/sqft	Substructure profile <b>ZSSW-LG3326V</b> joint 4 mm		1.52 ft/sqft (stacked bond) 1.74 ft/sqft (running bond)
Clip for fixed point <b>ZCLW-KK3015</b>		0.37 pcs/sqft	Screw <b>ZRHW-3.5X16-</b> <b>A2-7504N</b>		0.37 pcs/sqft
Rubber seal <b>ZAMW-RS-TH14830</b>		2.01 ft/sqft	Insertion tool <b>ZAMW-IT-TH14830</b>		1.00 pcs

## CORNERS COMPONENTS

Profile <b>JF7040-30x15</b>	
--------------------------------	---

**WARNING:** the incidences of accessory material indicated refer to application according to the European standards, which provides for planks 6' long and slats/substructure with maximum distance o.c. up to 12". For any installation that differs from the standard a cutting plan must be designed; it shall calculate precisely the number of points of intersection between the planks and the substructure, allowing the correct identification of the number of clips and screws required for each type of application.

# TH6050HD - outdoor cladding

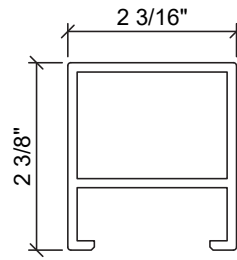

Woodn recommends to refer only to the values expressed in mm the US values are to be considered approximate).



## MOUNTING SYSTEM

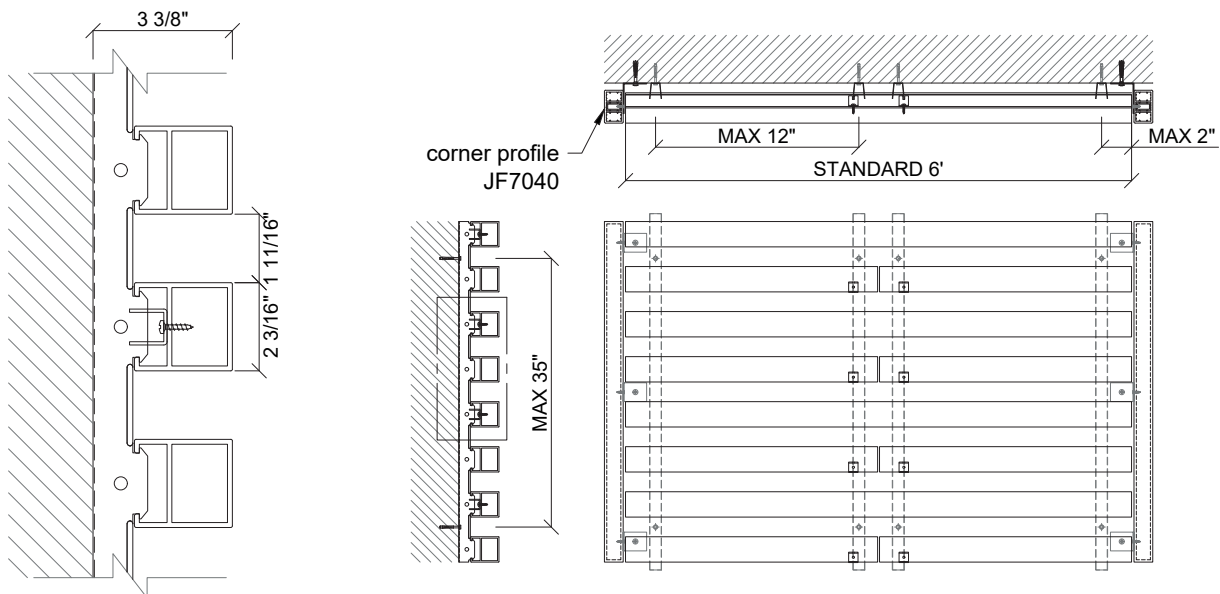

WEIGHT OF THE SYSTEM ≈ 2.93 lb/sqft  
 • Dimensions considering a standard wind load of 24.59 pound/sqft

# ASSEMBLY INSTRUCTIONS



1. Screw the ZSSW-LG9637V profiles to support with suitable screws and wall plugs (\*).

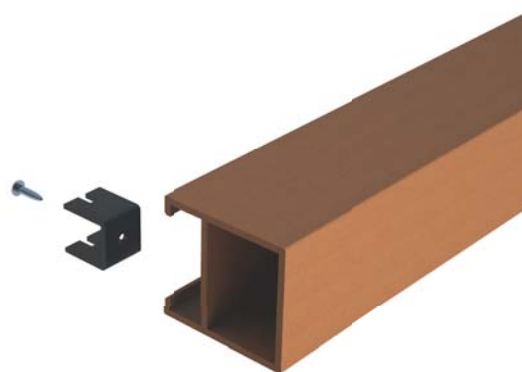

2. Apply the clip for the FIXED POINT with self-drilling screws to the profile.



3. Install the first TH6050HD profile.

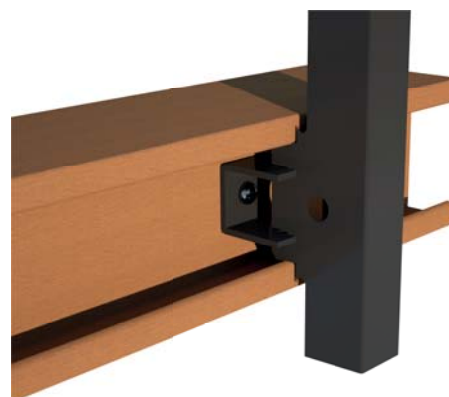

4. NOTE: the clip has to slot in the substructure.



5. Install, if expected, the accessory THZ5004HD profile.



6. Repeat as described from step 2 up to the top to complete the cladding.

\*Screws and wall plugs must be chosen according to the type of wall support.

# DETAILS FOR CORNERS



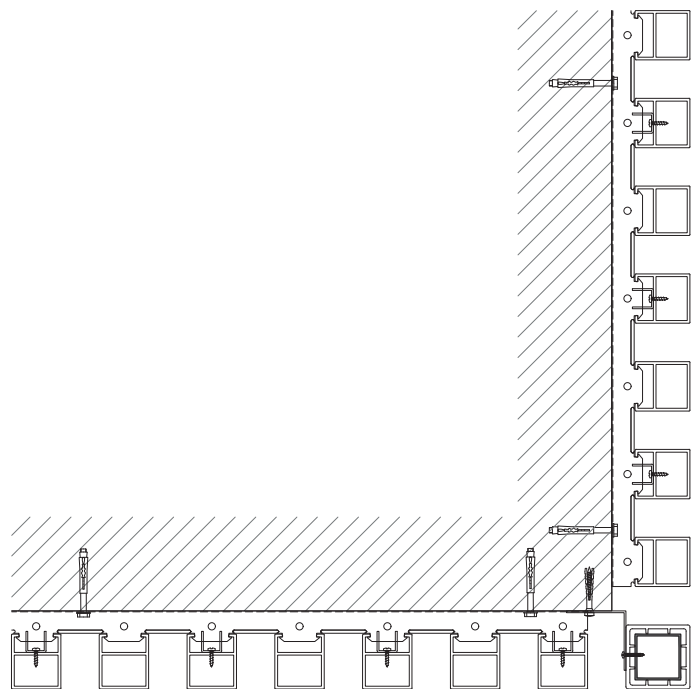

## VERTICAL PLANKS

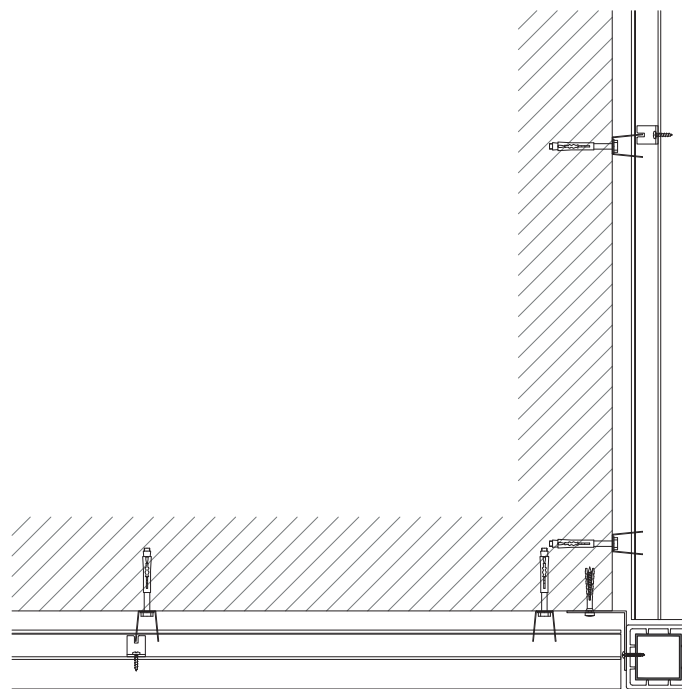



## HORIZONTAL PLANKS



## SYSTEM COMPONENTS

Profile <b>TH6050HD</b>		3.20 ft/sqft	Substructure profile <b>ZSSW-LG9637V</b>		1.52 ft/sqft (stacked bond) 1.74 ft/sqft (running bond)
Clip for fixed point <b>ZCLW-KK2722</b>		0.56 pcs/sqft	Screw <b>ZRHW-3.5X16-A2-7504N</b>		0.56 pcs/sqft
Accessory closing piece <b>THZ5004HD</b>		3.20 ft/sqft			









## CORNERS COMPONENTS

Profile <b>JF7040-30x15</b>		Profile <b>JF7070</b>	
--------------------------------	---	--------------------------	--

**WARNING:** the incidences of accessory material indicated refer to application according to the European standards, which provides for planks 6' long and slats/substructure with maximum distance o.c up to 12". For any installation that differs from the standard a cutting plan must be designed; it shall calculate precisely the number of points of intersection between the planks and the substructure, allowing the correct identification of the number of clips and screws required for each type of application.

# PROFILES SECTION

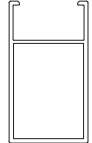
indoor ceiling/outdoor soffit

profile	cross-section	nominal dimensions [ft, in]	weight of the plank [lb/ft]
<b>TH5025HD</b> 		section 25 x 50 mm (≈ 1" x 2") standard length 1830 mm (≈ 6')	0.24
<b>TH3050HD</b> 		section 50 x 30 mm (≈ 2" x 1"3/16) standard length 1830 mm (≈ 6')	0.31
<b>TH6050HD</b> 		section 54 x 60 mm (≈ 2"3/16 x 2"3/8) standard length 1830 mm (≈ 6')	0.54
<b>TH9050HD</b> 		section 50 x 90 mm (≈ 2" x 3"9/16) standard length 1830 mm (≈ 6')	0.56
<b>TH14830HD-4</b> 		section 148 x 30 mm (≈ 5"13/16 x 1"3/16) standard length 1830 mm (≈ 6')	0.69

Woodn recommends to refer only to the values expressed in mm the US values are to be considered approximate).

The external dimensions listed are nominal values.  
 The weights of the planks indicated in the tables are indicative and not binding.  
 Length tolerances according UNI EN-ISO 22768: class UNI EN-ISO 22768-vL.

# TH5025HD - indoor ceiling/outdoor soffit

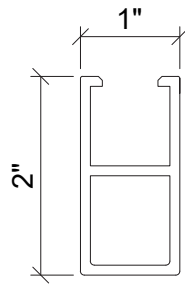

Woodn recommends to refer only to the values expressed in mm the US values are to be considered approximate).



## MOUNTING SYSTEM

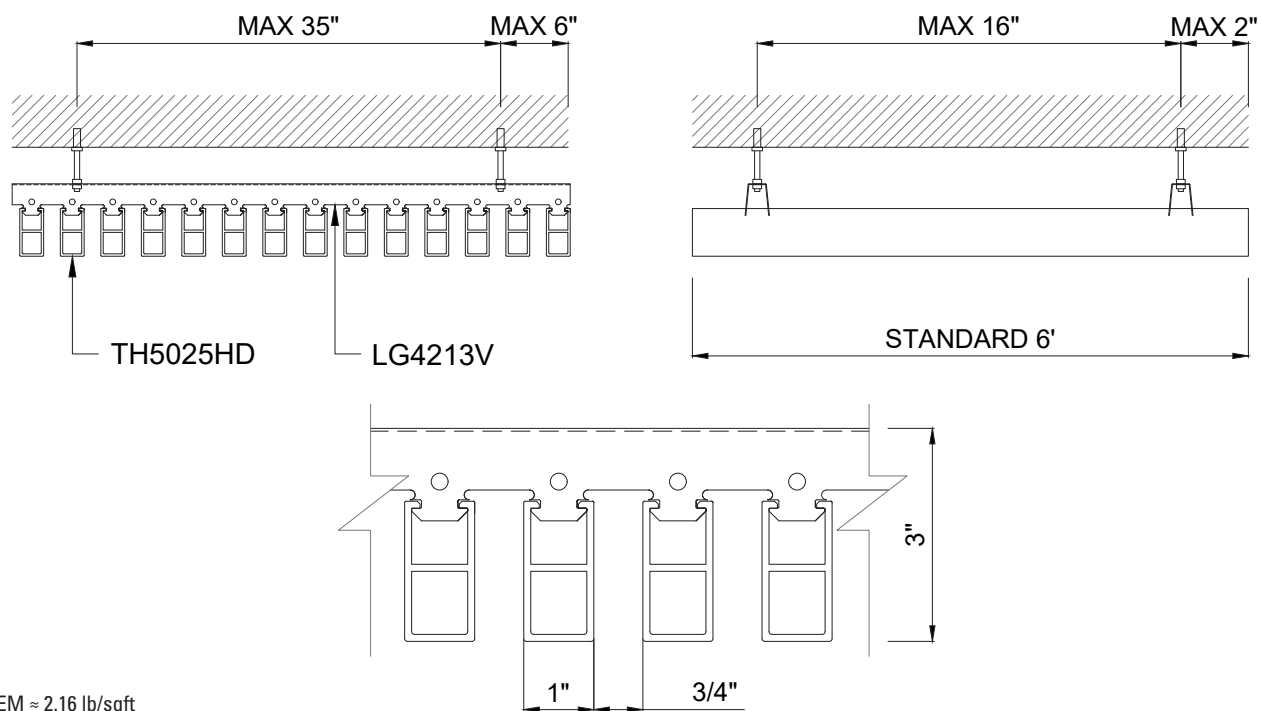

WEIGHT OF THE SYSTEM ≈ 2.16 lb/sqft

# ASSEMBLY INSTRUCTIONS

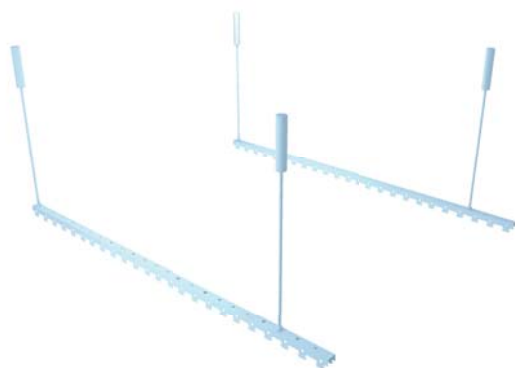

1. Fix the ZSSW-LG4213V bars directly to the ceiling using screws and wall plugs suitable for the type of support, or lower the structure with suitable hangers.

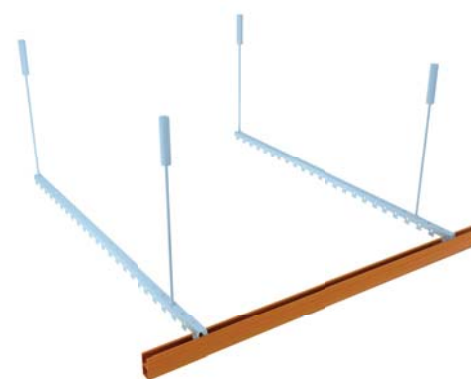

2. Install the first TH5025HD profile.



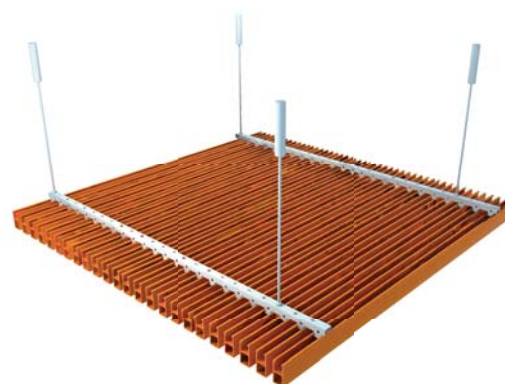

3. Attach the plank to the substructure.



4. Complete the work by repeating the steps described in 2 and 3.

NOTE: Hangers, screws and wall plugs not included. For outdoor installation, the perimeter of the ceiling must be closed on all sides.

## SYSTEM COMPONENTS

Profile <b>TH5025HD</b>		7.11 ft/sqft	Substructure profile <b>ZSSW-LG4213V</b>		1.19 ft/sqft (stacked bond) 1.40 ft/sqft (running bond)
----------------------------	---	--------------	---	---	--

WARNING: the incidences of accessory material indicated refer to application according to the European standards, which provides for planks 6' long and slats/substructure with maximum distance o.c. up to 16". For any installation that differs from the standard a cutting plan must be designed; it shall calculate precisely the number of points of intersection between the planks and the substructure, allowing the correct identification of the number of clips and screws required for each type of application.

# TH3050HD - indoor ceiling/outdoor soffit

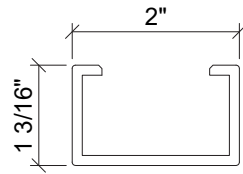

Woodn recommends to refer only to the values expressed in mm the US values are to be considered approximate).

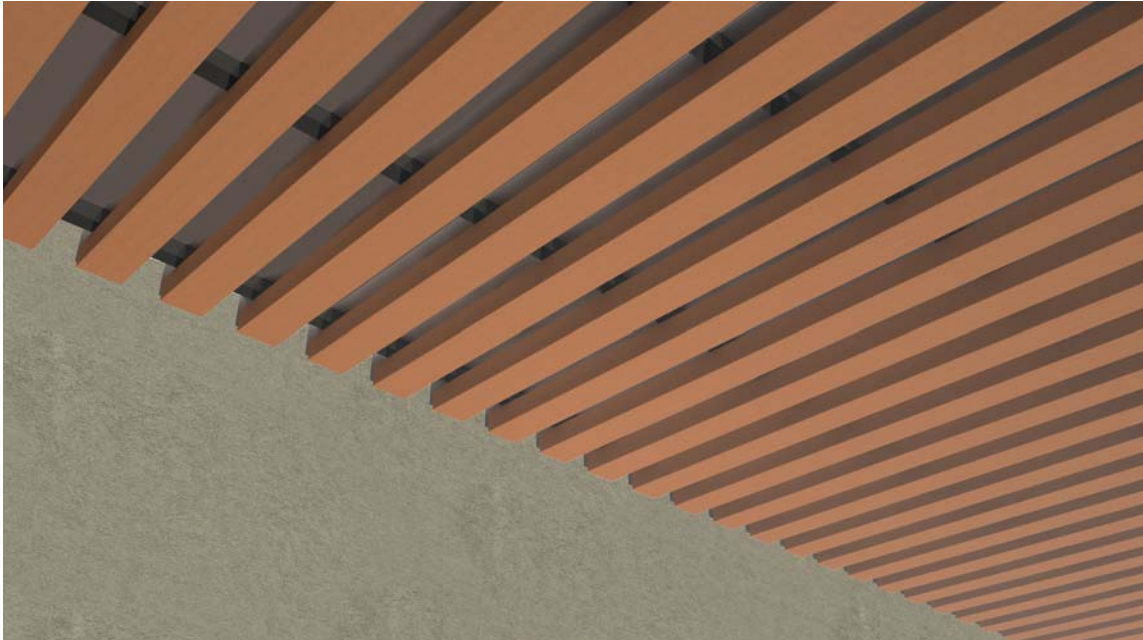

## MOUNTING SYSTEM

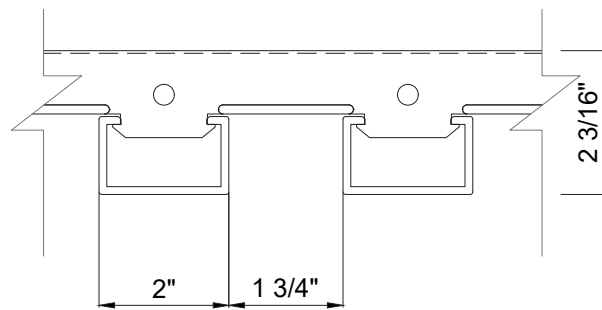
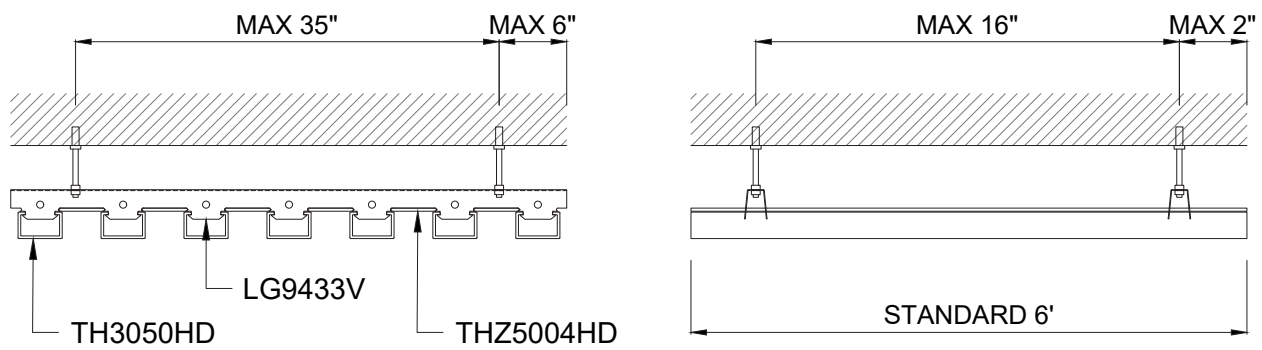

WEIGHT OF THE SYSTEM (without THZ5004HD)  $\approx$  1.43 lb/sqft  
WEIGHT OF THE SYSTEM (with THZ5004HD)  $\approx$  2.03 lb/sqft

# ASSEMBLY INSTRUCTIONS

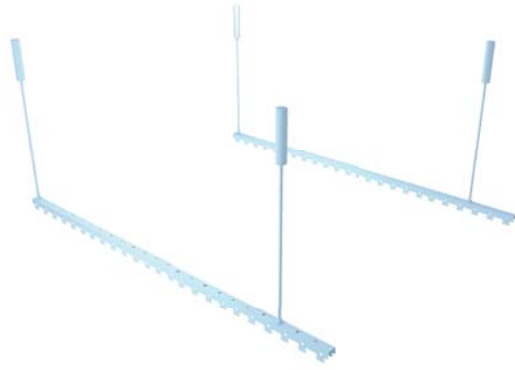

1. Fix the ZSSW-LG9433V bars directly to the ceiling using screws and wall plugs suitable for the type of support, or lower the structure with suitable hangers.

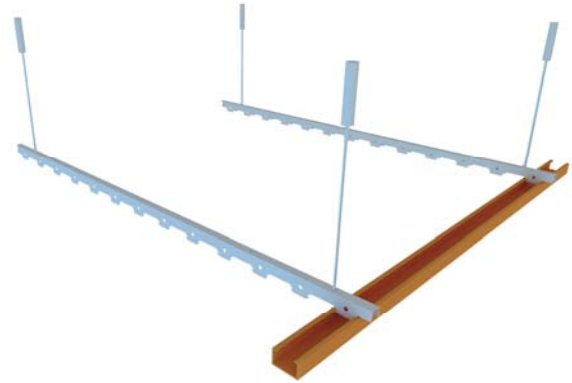

2. Install the first TH3050HD profile to the substructure.

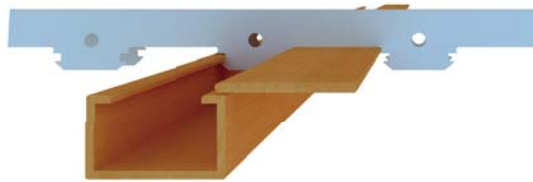

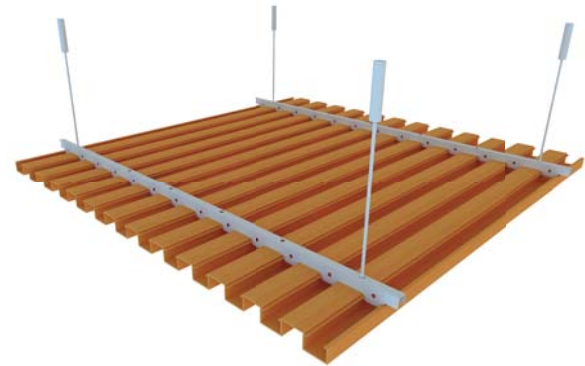

3. Install, if provided, the accessory profile THZ5004HD.



4. Complete the work by repeating the steps described in 2 and 3.

NOTE: Hangers, screws and wall plugs not included. For outdoor installation, the perimeter of the ceiling must be closed on all sides.

## SYSTEM COMPONENTS

Profile <b>TH3050HD</b>		3.20 ft/sqft	Substructure profile <b>ZSSW-LG9433V</b>		1.19 ft/sqft (stacked bond) 1.40 ft/sqft (running bond)
Accessory closing piece <b>THZ5004HD</b>		3.20 ft/sqft optional element for closing the false ceiling			

WARNING: the incidences of accessory material indicated refer to application according to the European standards, which provides for planks 6' long and slats/substructure with maximum distance o.c. up to 16". For any installation that differs from the standard a cutting plan must be designed; it shall calculate precisely the number of points of intersection between the planks and the substructure, allowing the correct identification of the number of clips and screws required for each type of application.

# TH6050HD - indoor ceiling/outdoor soffit

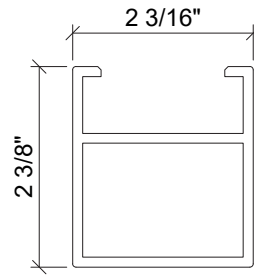

Woodn recommends to refer only to the values expressed in mm the US values are to be considered approximate).



## MOUNTING SYSTEM

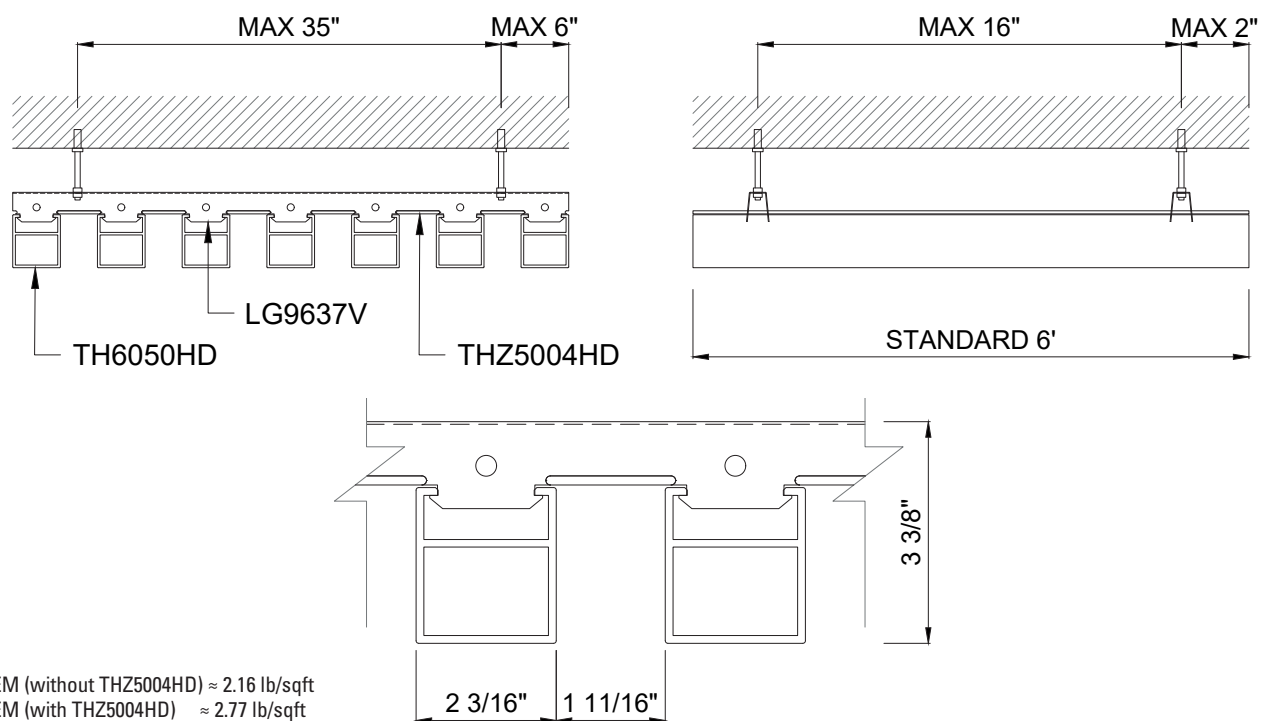

WEIGHT OF THE SYSTEM (without THZ5004HD)  $\approx$  2.16 lb/sqft  
 WEIGHT OF THE SYSTEM (with THZ5004HD)  $\approx$  2.77 lb/sqft

# ASSEMBLY INSTRUCTIONS

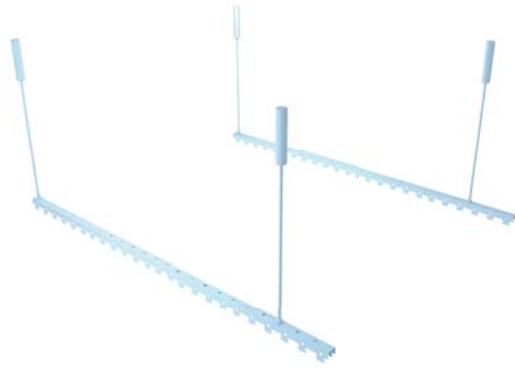

1. Fix the ZSSW-LG9637V bars directly to the ceiling using screws and wall plugs suitable for the type of support, or lower the structure with suitable hangers.



2. Install the first TH6050HD profile to the substructure.



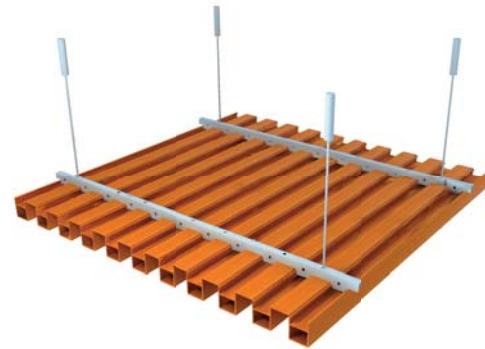

3. Install, if provided, the accessory profile THZ5004HD.



4. Complete the work by repeating the steps described in 2 and 3.

NOTE: Hangers, screws and wall plugs not included. For outdoor installation, the perimeter of the ceiling must be closed on all sides.

## SYSTEM COMPONENTS

Profile <b>TH6050HD</b>		3.20 ft/sqft	Substructure profile <b>ZSSW-LG9637V</b>		1.19 ft/sqft (stacked bond) 1.40 ft/sqft (running bond)
Accessory closing piece <b>THZ5004HD</b>		3.20 ft/sqft optional element for closing the false ceiling			

WARNING: the incidences of accessory material indicated refer to application according to the European standards, which provides for planks 6' long and slats/substructure with maximum distance o.c. up to 16". For any installation that differs from the standard a cutting plan must be designed; it shall calculate precisely the number of points of intersection between the planks and the substructure, allowing the correct identification of the number of clips and screws required for each type of application.

# TH9050HD - indoor ceiling/outdoor soffit

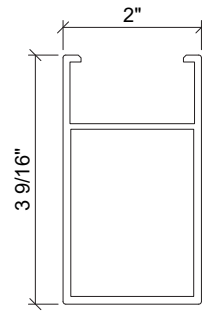

Woodn recommends to refer only to the values expressed in mm the US values are to be considered approximate).



## MOUNTING SYSTEM

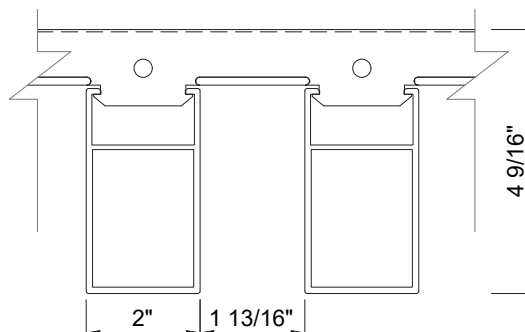
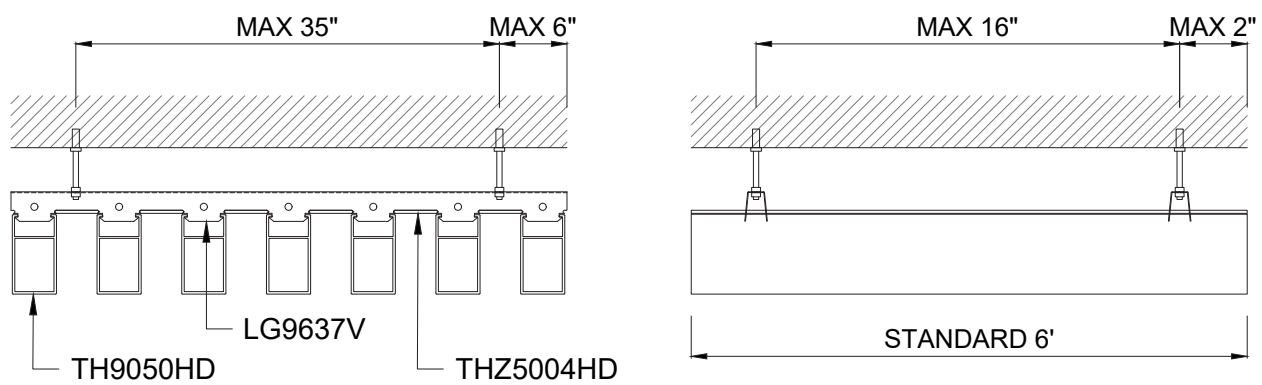

WEIGHT OF THE SYSTEM (without THZ5004HD)  $\approx$  2.23 lb/sqft  
WEIGHT OF THE SYSTEM (with THZ5004HD)  $\approx$  2.83 lb/sqft

# ASSEMBLY INSTRUCTIONS

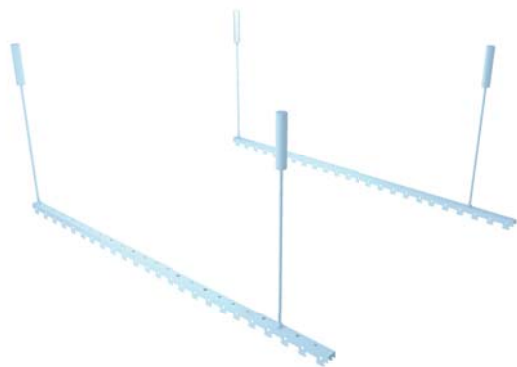

1. Fix the ZSSW-LG9637V bars directly to the ceiling using screws and wall plugs suitable for the type of support, or lower the structure with suitable hangers.



2. Install the first TH9050HD profile to the substructure.



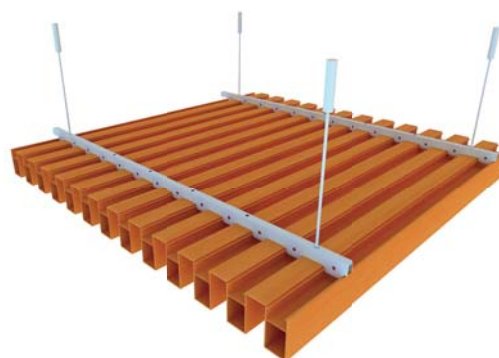

3. Install, if provided, the accessory profile THZ5004HD.



4. Complete the work by repeating the steps described in 2 and 3.

NOTE: Hangers, screws and wall plugs not included. For outdoor installation, the perimeter of the ceiling must be closed on all sides.

## SYSTEM COMPONENTS

Profile <b>TH9050HD</b>		3.20 ft/sqft	Substructure profile <b>ZSSW-LG9637V</b>		1.19 ft/sqft (stacked bond) 1.40 ft/sqft (running bond)
Accessory closing piece <b>THZ5004HD</b>		3.20 ft/sqft optional element for closing the false ceiling			

WARNING: the incidences of accessory material indicated refer to application according to the European standards, which provides for planks 6' long and slats/substructure with maximum distance o.c. up to 16". For any installation that differs from the standard a cutting plan must be designed; it shall calculate precisely the number of points of intersection between the planks and the substructure, allowing the correct identification of the number of clips and screws required for each type of application.

# TH14830HD-4 - indoor ceiling/outdoor soffit

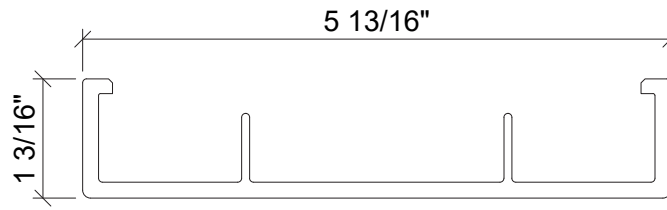

Woodn recommends to refer only to the values expressed in mm the US values are to be considered approximate).



## MOUNTING SYSTEM

JOINT 40 mm (≈ 1"9/16")

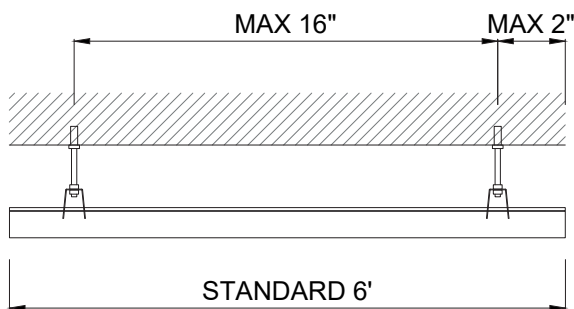
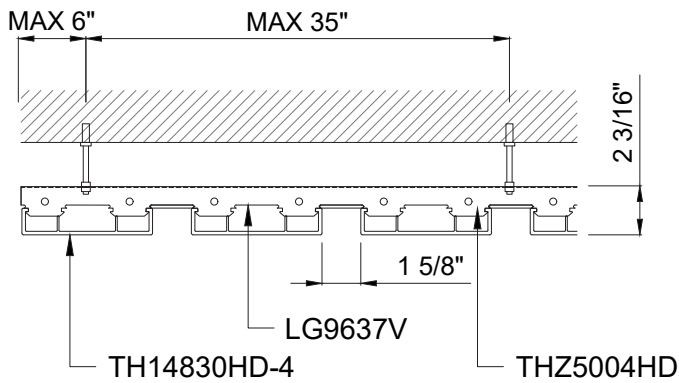

WEIGHT OF THE SYSTEM (without THZ5004HD) ≈ 1.58 lb/sqft  
 WEIGHT OF THE SYSTEM (with THZ5004HD) ≈ 1.90 lb/sqft

REV.00-2020

JOINT 4 mm (≈ 5/32")

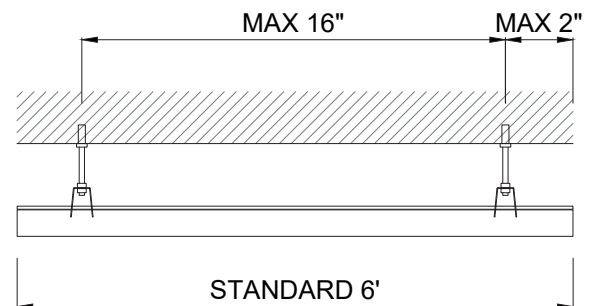
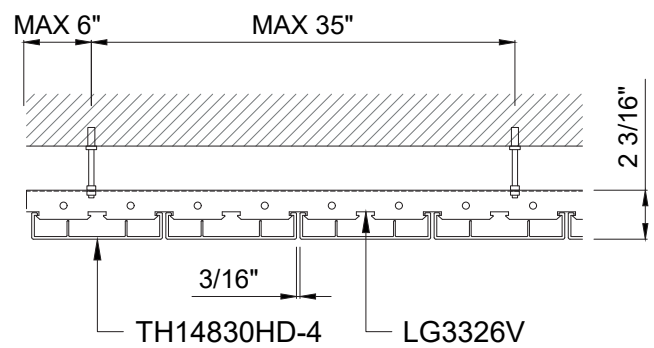

WEIGHT OF THE SYSTEM (joint 5/32") ≈ 1.84 lb/sqft

pag. 96

# ASSEMBLY INSTRUCTIONS

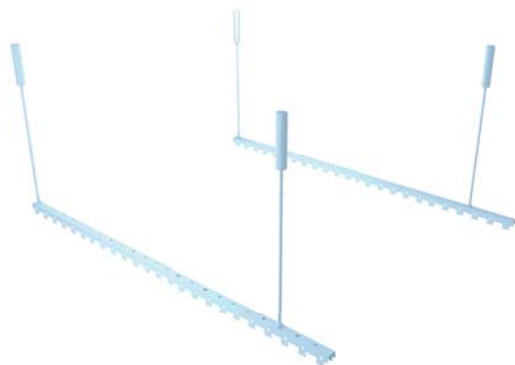

1. Fix the ZSSW-LG9637V or ZSSW-LG3326V bars directly to the ceiling using screws and wall plugs suitable for the type of support, or lower the structure with suitable hangers.

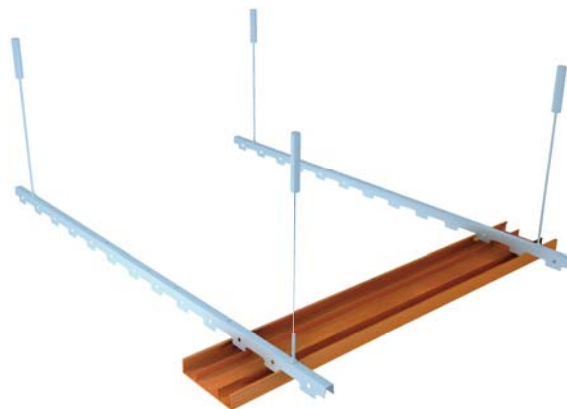



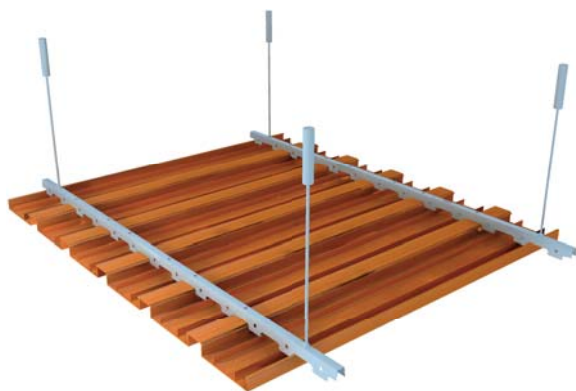

2. Install the first TH14830HD-4 profile, fitting the planks to the substructure, alternating them with the THZ5004HD profiles if applicable.



3. Complete the work by repeating the steps described in 2.

NOTE: Hangers, screws and wall plugs not included. For outdoor installation, the perimeter of the ceiling must be closed on all sides.

## SYSTEM COMPONENTS

Profile <b>TH14830HD-4</b>		1.65 ft/sqft (joint 1"9/16) 2.01 ft/sqft (joint 5/32")	Substructure profile <b>ZSSW-LG9637V</b> joint 1"9/16		1.19 ft/sqft (stacked bond) 1.40 ft/sqft (running bond)
Accessory closing piece piece <b>THZ5004HD</b>		1.65 ft/sqft (joint 1"9/16)	Substructure profile <b>ZSSW-LG3326V</b> joint 5/32"		1.19 ft/sqft (stacked bond) 1.40 ft/sqft (running bond)

WARNING: the incidences of accessory material indicated refer to application according to the European standards, which provides for planks 6' long and slats/substructure with maximum distance o.c. up to 16". For any installation that differs from the standard a cutting plan must be designed; it shall calculate precisely the number of points of intersection between the planks and the substructure, allowing the correct identification of the number of clips and screws required for each type of application.

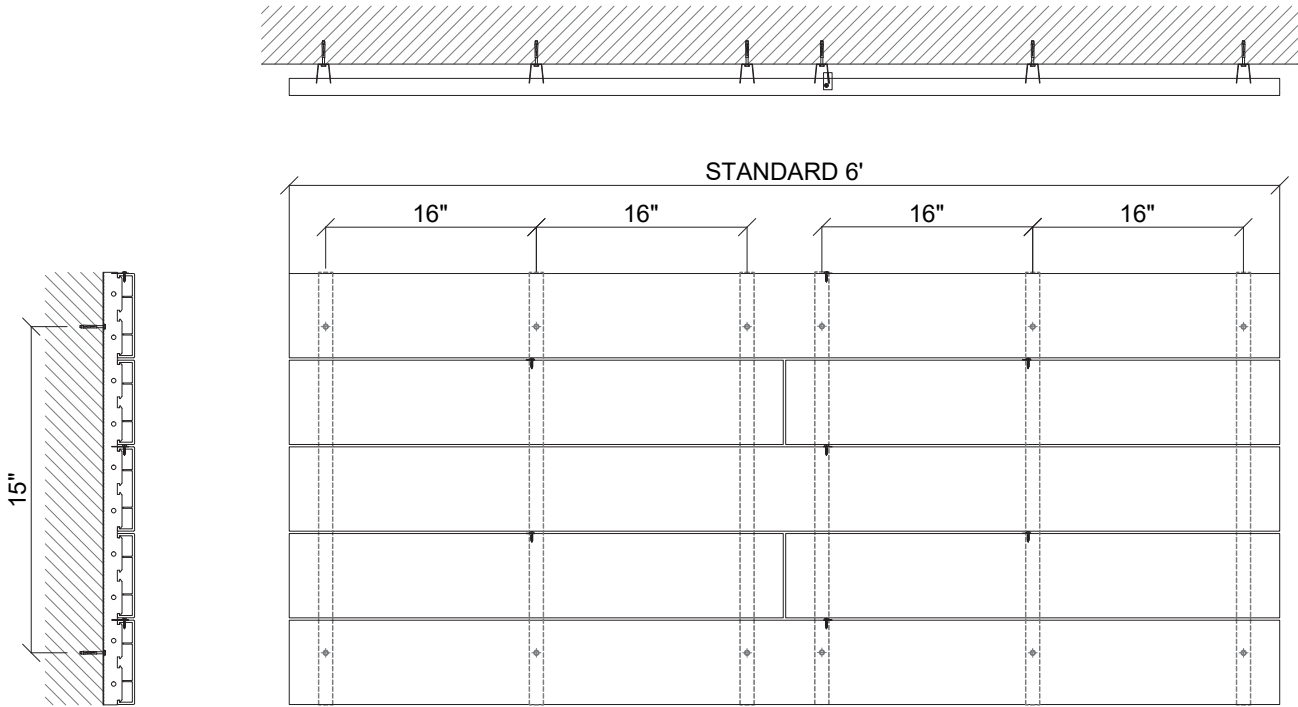

7341 Westport Pl Suite 1A, West Palm Beach, FL 33413  
 Phone: 561-508-2830 E-mail: Eng@bw@blackwaterinc.com  
 REPORT NO: BT-FLS-16-002A1 MIAMI-DADE CERTIFICATION #14-0911.04 03/14/2016  
 Test Dates: 03/11/2016 to 03/14/2016

**TESTING FOR UNIFORM STATIC AIR PRESSURE TAS 202-94 AND CYCLIC LOADS TAS 203-94 OF "TH14830HB 16" O.C. WOODN CEILING"**

**Client:**  
**WOODN INDUSTRIES SRL.**  
 Via Ippolito Caffi, 17  
 32100 Belluno (BL), Italy  
 Office Phone: (+39) 049 89.60.706

Specimen 1-2-3

**Product Description of Unit:** TH14830HB 16" O.C. Woodn Ceiling  
**Overall Size:** Sp 1-2-3 49"X35-1/8"  
**Test Buck Size:** Sp 1-2-3 49-1/2"X35-5/8"  
**Test Protocol:** Sp 1-2-3 TAS 202-94@+/-150psiDP---TAS 203-94@+/-150psiDP

**Disclaimer:**  
 This is a general statement and does not supersede the specific product descriptions in this report. The specimens are in conformance with attached Drawings. These drawings have been marked to indicate the appropriate portions descriptive of this test series. Blackwater Testing Inc. does not take responsibility of product performance and whose only purpose is to test and gather pertinent data under test report format for the client.

**Witness to Testing:**  
 Dennis Duffy, BT CEO  
 Erik Coppola, BT Lab Technician  
 Yamil G. Kuri, P.E. Test Engineer

Reports pertaining to the samples tested only and may not be reproduced without permission.  
 BT-FLS-16-002A1 03/14/2016 Page 1  
 MAR 3 1 2016



# Ceiling/soffit substructures

(lengths and details of the supplied items)

LG9637V for TH6050HD, TH9050HD, TH14830HD-4 (joint 1" 9/16)

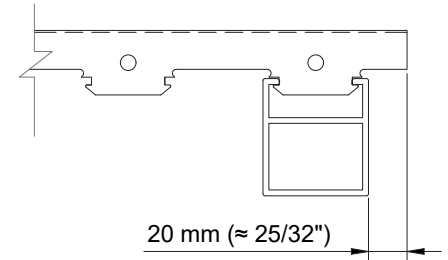
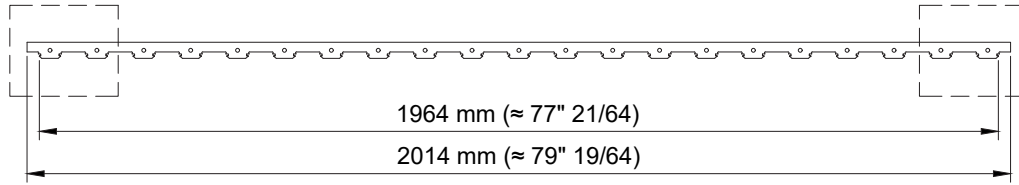

LG9433V for TH3050HD

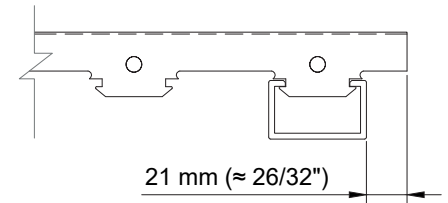
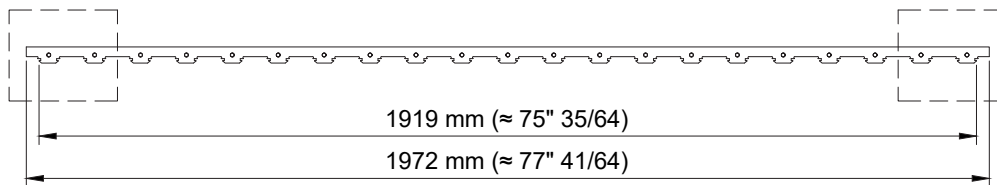

LG4213V for TH5025HD

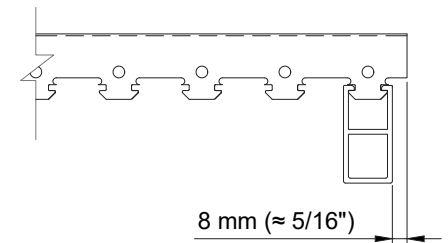
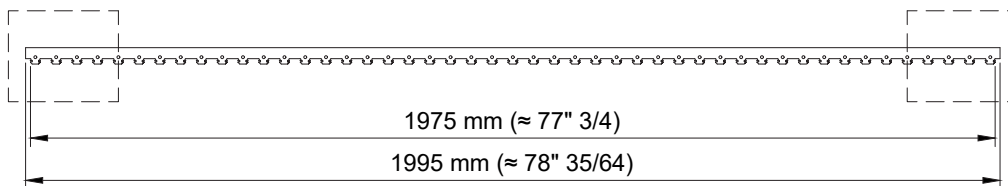

LG3326V for TH14830HD-4 (joint 5/32")

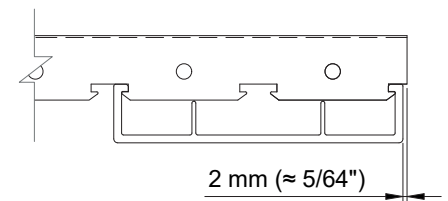
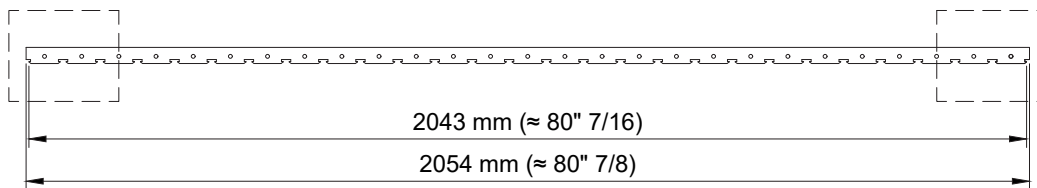

The dimensions listed are nominal values.  
Length tolerances according UNI EN-ISO 22768: class UNI EN-ISO 22768-vL.

# Solutions for the ceiling/soffit closure

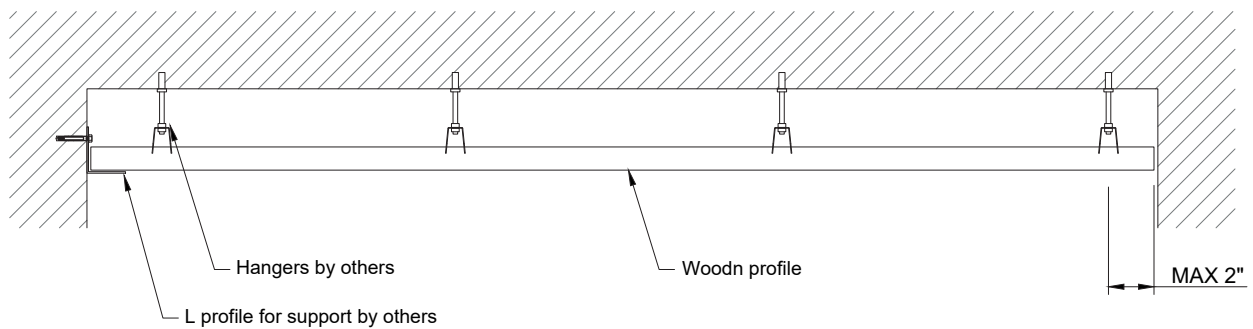
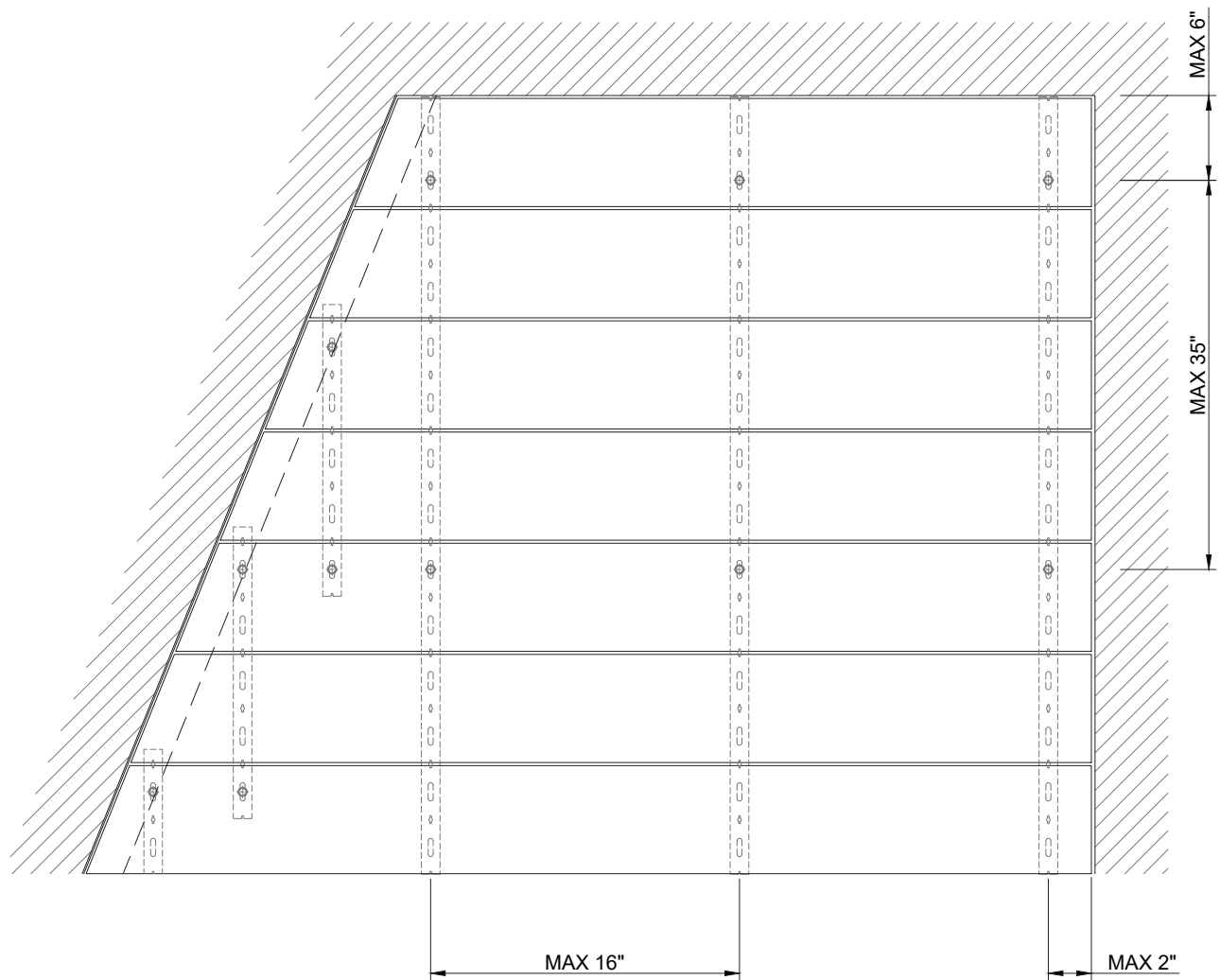

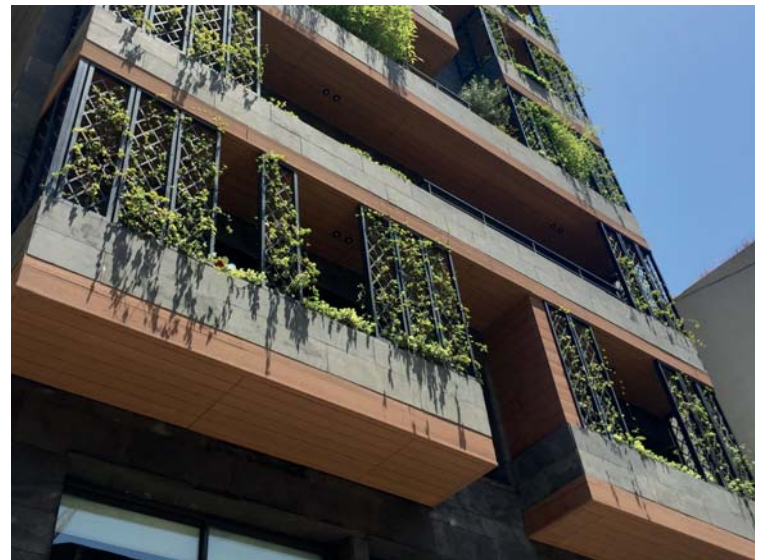
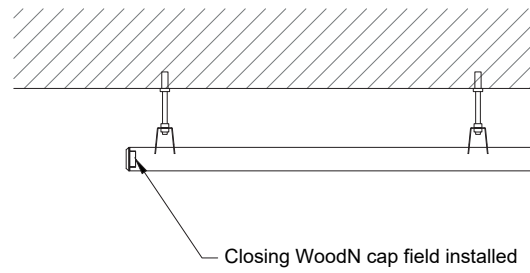
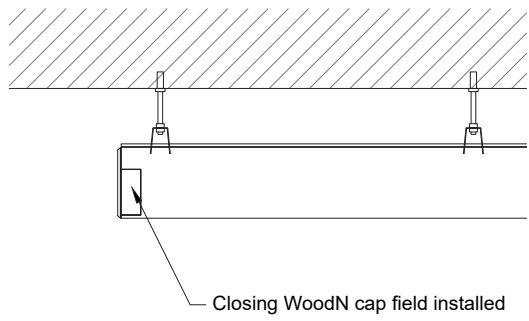
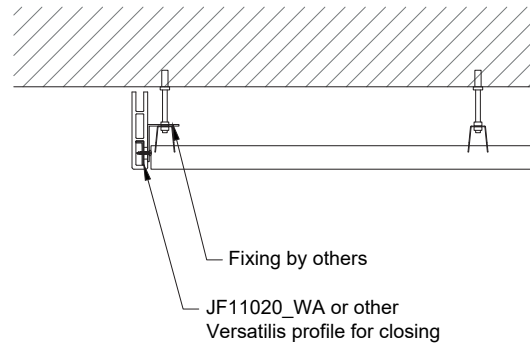
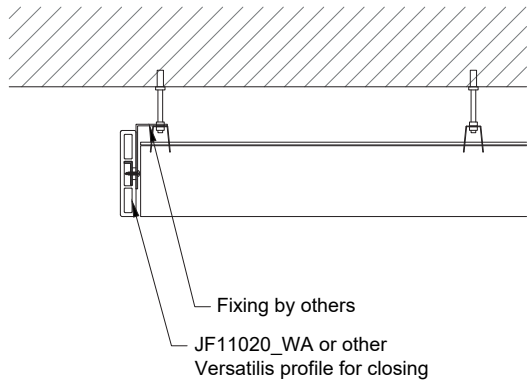

# Drill to position lights and other recessed elements

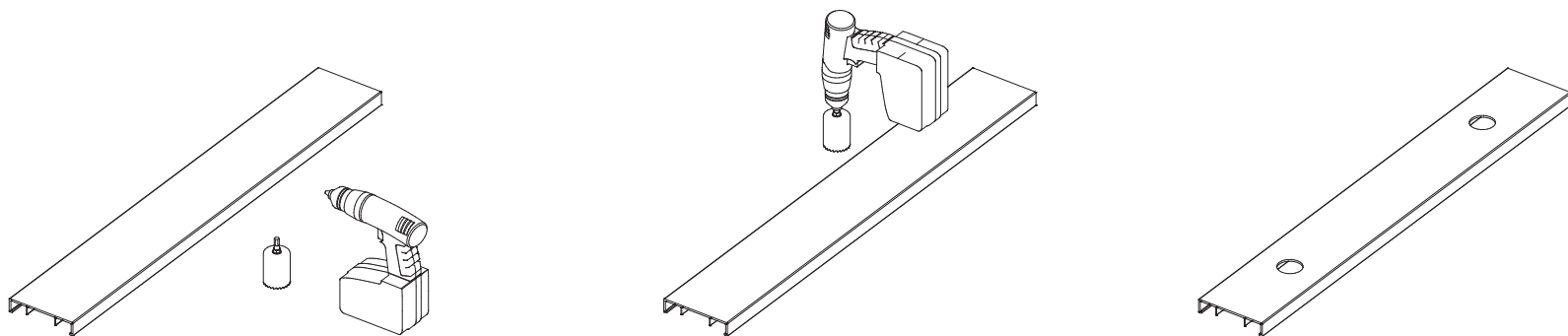

**WARNING: any lights and other recessed elements must be fixed to a support structure and not directly on the plank.**



# WOODN ORNANS

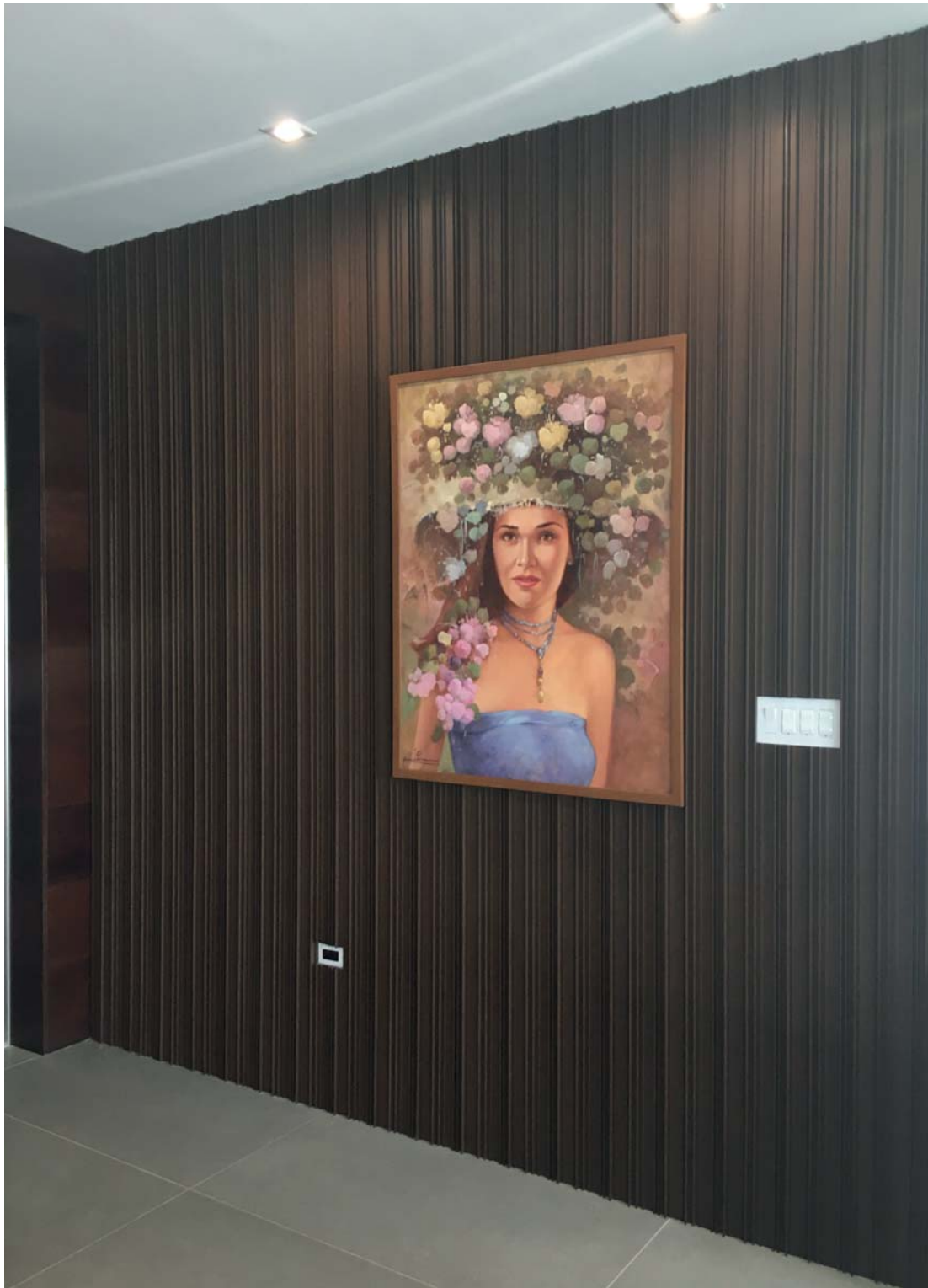

#### DISCLAIMER - GENERAL NOTES

Due to conversion from metric sizes and measurements, the US values provided are approximate.

The information provided by WoodN Industries in this document are solely indicative, they are based on the present state of knowledge and must be considered only as a description of our products and their possible application. Such information must not be interpreted as a guarantee of specific features, performances or warranties of the product. Material's colors and finishes represented in this document are the result of printing techniques so they may slightly differ from the original colors. Original samples are available upon request and constitute only a general indication of the dimensions and the aesthetic appearance of Woodn™ profiles. WoodN Industries may change the information included in this document at any time and without further notice. WoodN Industries does not warrant the accuracy and completeness of the information in this document and furthermore their suitability for the purpose which it is consulted for by the other parties. WoodN's customers or third parties must ascertain they have the most recent version of this document, available at [www.woodn.com](http://www.woodn.com). It is advised that customers and third parties have a professional adviser to inform them about the suitability of the products for all desired applications and about applicable laws and regulations. WoodN Industries reserves the right to modify products and concerning features without prior notice. WoodN Industries is not liable for any damage arising from, or related to, the use of this document. Woodn™ material does not have structural characteristics and therefore WoodN Industries declines all responsibilities for improper use of the material. No sections of this publication can be reproduced, stored in database, or transmitted in any form or by any other mean without the explicit approval of WoodN Industries. For more information please contact WoodN Industries.

# MATERIAL'S FEATURES

## Mechanical properties

Elasticity (bending)	UNI EN ISO 178	@73 °F @149 °F
Yield strenght (flexural)	UNI EN ISO 178	@73 °F @149 °F
Water absorbption and humidity	ASTM D1037	absorption 0,07%
Dynamic- Mechanical analysis of transition temperature	ASTM D4065/95	173.8 °F
Linear thermal expansion coefficient (from 14 °F to 158 °F)	TMA ASTM E 831/2006	longitudinal $46,9 \times 10^{-6} \text{ m}/(\text{m}^{\circ}\text{C})$ trasversal $48 \times 10^{-6} \text{ m}/(\text{m}^{\circ}\text{C})$
Tensile strenght and tensile strenght after accelerated weathering (exposure to xenon lights)	ASTM D638-10 (tensile test) ASTM G155-050	difference after 2 months of exposure ~5,21% difference after 3 months of exposure ~6,9% (meet the requirements to comply with Miami Dade and Florida Building Code 2014)

## Reaction to fire

Flammability	UL94 AS 3959-2009	V-0 Class BAL-29
Flame spread index Smoke developed index	ASTM E84	Class A
Ignition temperature	ASTM D1929	890 °F
Average critical radiant flux of floor	AS ISO 9239 ASTM E648	$\geq 11 \text{ kW}/\text{m}^2$ $> 1,03 \text{ W}/\text{cm}^2$ (class I as per NFPA 101)
Ignitability, flame propagation, heat release and smoke release	AS/NZS 1530.3:1999	Ignitability (0-20) = 8 Spread of Flame (0-10) = 0 Heat Evolved (0-10) = 0 Smoke Developed (0-10) = 7

## Chemical and biological features





Evaluation of the action of microorganisms (scale from 0 to 5)	EN ISO 846:97	Test result: 1
Heavy metal content (Pb, Ge, Cr, Hg)	GB18584-2001 GB18580-2001	< 0,5 ppm
Formaldehyde emission	EN 717-2:1994	0,1 mg HCHO/(m <sup>2</sup> h)

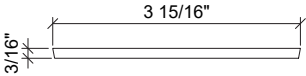

The values shown are indicative and not binding. Test reports available upon request.  
The natural aging of the material and temperature variations may cause deviations from the values indicated above.  
The product is protected by a warranty in line with legal requirements: for more information see the SPECS on [www.woodn.com](http://www.woodn.com)

# PROFILES SECTION

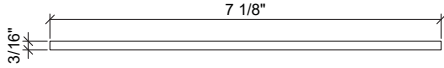
Woodn recommends to refer only to the values expressed in mm the US values are to be considered approximate).

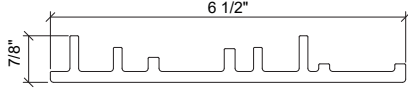
profile	cross-section	nominal dimensions [ft,in]	weight of the plank [lb]	number of planks per sqft
<b>WIT10004R</b> 		section 100 x 4 mm (≈ 3"15/16 x 3/16") standard length 1830 mm (≈ 6')	≈ 1.92	0.46
<b>WIT18004R</b> 		section 180 x 4 mm (≈ 7"1/8 x 3/16") standard length 1830 mm (≈ 6')	≈ 3.78	0.26
<b>Q16422</b> 		section 164 x 22 mm (≈ 6"1/2 x 7/8") standard length 1830 mm (≈ 6')	≈ 5.88	0.28

The Woodn Ormans cladding is brushed on the backside to allow a proper fixing with the adhesive.

## CORNERS COMPONENTS

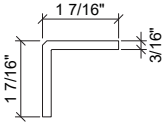
Profile <b>WITK3535A</b>			section 35 x 35 mm (≈ 1"7/16 x 1 7/16") standard length 1830 mm (≈ 6')	inner and outer corner
-----------------------------	---	--	--	------------------------

The external dimensions listed are nominal values.  
 The weights of the planks indicated in the tables are indicative and not binding.  
 Length tolerances according UNI EN-ISO 22768: class UNI EN-ISO 22768-vL.

# GENERAL INSTALLATION INSTRUCTIONS

Key points to be followed before and during the installation process:

- Store the material on a flat surface providing for a stable support on the whole surface, in a dry, clean area, protected from frost and direct sun light.
- Before starting the installation, carefully check the material and notify immediately of any manufacturing issues. Complaints will not be accepted after installation.
- Before starting the installation, check project's drawings (or shop drawings if provided) and the correspondence of the received material against the packing list.
- Acclimate the material in stock to the temperature of the jobsite for at least 48 hours prior to installation.
- The installation temperature must be higher than 32 °F.
- Do not cover the product with sheets made with non-breathable material (nylon, polyethylene and similar materials). For this purpose it is advisable to use breathable material such as painter felt sheets.
- The accumulation of electrostatic charges is a natural phenomenon commonly found in plastic materials, and under exceptional environmental conditions this may also occur in Woodn™'s products.
- Profiles shall be handled with care in order to prevent damages. It is recommended to lift the profiles on the whole length during displacement and not make them slide on top of each other. Always use clean fabric gloves when handling profiles.
- Prevent the formation of dirt on and between profiles; in particular, make sure that mechanical processes carried out on other materials, near Woodn products, do not determine the accumulation of chips or dust of any kinds. During the installation/assembly phase do not apply any label or sticker; if already applied, please remove immediately after installation. Immediately remove major stains such as paint, concrete or tar residues.
- For cleaning and maintenance instructions refer to page 115. The WoodN warranty will be rendered null and void in the event of incorrect or improper handling, cleaning and maintenance.

## PREPARATION OF THE BASE

Check the stability of the support on which the installation will be carried out: a surface subject to expansion and movements of any kind can compromise the success of the installation. For an easy, fast and safe installation of Woodn™ Ormans, a properly levelled substrate is required. Any irregularities of the floor and wall will affect the surface of the cladding.

Before applying the adhesive to the substrate, check the following:

- cleanliness (namely: the absence of oily or greasy substances in general, which may jeopardise the adhesion of the adhesive to the substrate; absence of debris, which may seriously compromise the aesthetic result of the installation);
- absence of surface and rising moisture.

## ADHESIVE

Installation may be carried out correctly using different types of adhesive among those available on the market. We recommend using the following products depending on the substrate on which you perform the application.

**WoodN Industries does not take responsibility for the bonding and laying methods.**

The amount of adhesive to be prepared depends on the experience and skill of the installer, on the "open time" of the adhesive (catalysis rate) and on the ambient temperature (heat accelerates the catalysis while a low temperature can slow down the process): we recommend carefully reading the instructions for use.

To apply the adhesive properly, **use a trowel with triangular teeth (5/64" is ideal)**. Then prepare a **uniform base** of adhesive on an appropriate portion of the surface you need to cover (size varies depending on the dexterity of the installer).

It may happen that for every 215 sqft to 323 sqft of laying, the teeth of the trowel become worn to the point of not allowing for an ideal application. In this case, we recommend promptly replacing the trowel.

products	cured and consolidated plaster*	dusty plaster*	plaster*	plasterboard*	cured and consolidated screed	dusty screed*	plastics**	metals**	ceramics**	cured and consolidated screed***
<b>MAPEI KERALASTIC</b> two-component polyurethane					•		•	•	•	•
<b>MAPEI KERALASTIC T</b> two-component polyurethane	•	•	•	•	•	•	•	•	•	•
<b>SLC-KERAKOLL SLCPU31 PRIMER</b> polyurethane single-component solvent (to use before the adhesive)		•				•				
<b>SLC-KERAKOLL SLCEP21 PRIMER</b> epoxy single-component (to use before the adhesive)		•				•				
<b>SLC-KERAKOLL L34</b> two-component epoxy-polyurethane	•	•	•	•	•	•				
<b>TOVER PRIMERFIX</b> (to use before the adhesive)		•				•				
<b>TOVER TOVCOL PU 2C</b> two-component polyurethane	•	•	•	•	•	•	•	•	•	•
<b>TOVER TOVCOL T91</b> two-component epoxy-polyurethane					•	•	•	•	•	•
<b>TOVER TOVCOL T91-V</b> two-component epoxy-polyurethane	•	•	•	•	•	•	•	•	•	•

\* Absorbent floors (indoors) \*\* Non-absorbent floors \*\*\* Outdoor applications

## WALL APPLICATION

A smooth wall free from surface irregularities is required for the laying stage, as described above. For application on a wall, we recommend proceeding from the bottom up. It is important to gradually check the correct positioning of the planks so you can correct any irregularities before the adhesive catalyses. Apply an even layer of adhesive on the portion of surface you need to cover and then apply the planks; until you complete the cladding. To prevent downwards slippage of the planks, fix them using pins or small nails that can later be removed once the adhesive catalyses.

For outdoor applications, the surface must be made with a hydraulic binder, have high mechanical strength and be compact and cured at the time of installation. We also recommend using planks less than or equal to 500 mm length ( $\approx 20''$ ).

## FLOOR APPLICATION

The Woodn™ Ornans planks can also be applied on the floor: for example, in bathrooms or rooms of private homes, shop windows and in general areas with foot traffic (equivalent to class 21 according to EN 685:2007). Installation on the floor must be carried out without stepping on freshly-laid planks, therefore it must be done by moving backwards across the room towards the exit. Do not walk on the floor for at least 24 hours after completing the installation.

Once the installation is done, to limit surface abrasions and scratches on the planks we recommend creating a 'buffer zone', using loose-laid mats according to standard EN14041. Please make sure that the mechanical properties of the product (see p.113) are compatible with the intended use of the floored premises.

Woodn recommends to refer only to the values expressed in mm the US values are to be considered approximate).

## TIPS FOR LAYING

The plank should be laid with a movement perpendicular to the application surface, make sure you do not slide it parallel to the substrate. Every 32 sqft to 43 sqft laid, apply pressure on the widest possible surface to make the planks adhere evenly to the substrate, using square trowels with a rubber base. For this step, we do not recommend using your fingers or the palm of your hand. Any excess adhesive should be eliminated as you go, to keep the adhesive from adhering to the visible surfaces. The adhesive may harden long after the laying itself (for instance, when the laying is done in low temperature environments). In these cases we recommend passing the square trowel a second time, if necessary. We recommend until the hardening is completed, using adhesive tape from a body shop (made of paper and with low adhesiveness) to hold the planks together, in order to avoid cracks forming between them.

## ROUTINE MAINTENANCE

The material is water resistant and can be washed with traditional liquids such as water, neutral soap, alcohol, etc. Carefully avoid using solvents (especially acetone) that could damage the surface of the planks. For example, the cladding can be washed with neutral soap and/or a capful of ammonia per each 5 L bucket of water. To remove dust, we recommended avoiding the use of abrasive tools, such as sorghum brooms. We recommend checking the level of wear of the brushes in your vacuum cleaner, in order to avoid scratches.



For special applications please contact our Woodn Industries' technical department. As part of a normal technological evolution, there may be changes in colour/appearance of the product; we recommend requesting recently-made samples when you order. We will not accept claims involving differences in colour or appearance outside commercial tolerances, if choices have been made based on old samples. We reserve the right to terminate, update, make technical changes to improve the quality and appearance of the material, without prior notice.



# HANDLING, CLEANING AND MAINTENANCE NOTES



#### DISCLAIMER - GENERAL NOTES

Due to conversion from metric sizes and measurements, the US values provided are approximate.

The information provided by WoodN Industries in this document are solely indicative, they are based on the present state of knowledge and must be considered only as a description of our products and their possible application. Such information must not be interpreted as a guarantee of specific features, performances or warranties of the product. Material's colors and finishes represented in this document are the result of printing techniques so they may slightly differ from the original colors. Original samples are available upon request and constitute only a general indication of the dimensions and the aesthetic appearance of Woodn™ profiles. WoodN Industries may change the information included in this document at any time and without further notice. WoodN Industries does not warrant the accuracy and completeness of the information in this document and furthermore their suitability for the purpose which it is consulted for by the other parties. WoodN's customers or third parties must ascertain they have the most recent version of this document, available at [www.woodn.com](http://www.woodn.com). It is advised that customers and third parties have a professional adviser to inform them about the suitability of the products for all desired applications and about applicable laws and regulations. WoodN Industries reserves the right to modify products and concerning features without prior notice. WoodN Industries is not liable for any damage arising from, or related to, the use of this document. Woodn™ material does not have structural characteristics and therefore WoodN Industries declines all responsibilities for improper use of the material. No sections of this publication can be reproduced, stored in database, or transmitted in any form or by any other mean without the explicit approval of WoodN Industries. For more information please contact WoodN Industries.

# HANDLING, CLEANING AND MAINTENANCE

This document is intended to provide general recommendations only.

## HANDLING AND STORAGE

Key points to be followed before and during the installation process:

- Store the material on a flat surface providing for a stable support on the whole surface, in a dry, clean area, protected from frost and direct sun light.
- Before starting the installation, carefully check the material and notify immediately of any manufacturing issues. Complaints will not be accepted after installation.
- Before starting the installation, check project's drawings (or shop drawings if provided) and the correspondence of the received material against the packing list.
- Acclimate the material in stock to the temperature of the jobsite for at least 48 hours prior to installation.
- The installation temperature must be higher than 32 °F.
- Do not cover the product with sheets made with non-breathable material (nylon, polyethylene and similar materials). For this purpose it is advisable to use breathable material such as painter felt sheets.
- The accumulation of electrostatic charges is a natural phenomenon commonly found in plastic materials, and under exceptional environmental conditions this may also occur in Woodn™'s products.
- Profiles shall be handled with care in order to prevent damages. It is recommended to lift the profiles on the whole length during displacement and not make them slide on top of each other. Always use clean fabric gloves when handling profiles.
- Prevent the formation of dirt on and between profiles; in particular, make sure that mechanical processes carried out on other materials, near Woodn products, do not determine the accumulation of chips or dust of any kinds. During the installation/assembly phase do not apply any label or sticker; if already applied, please remove immediately after installation. Immediately remove major stains such as paint, concrete or tar residues.

## CLEANING AND MAINTENANCE

Although WoodN requires minimum maintenance, as all the exterior building materials it's recommended to clean the material upon completion of installation, then regularly under normal conditions of use. As ordinary maintenance it is advised to carry out periodical cleaning, as needed, **using pressure water and, possibly, neutral detergent** (upon completion, it is advised to remove excess water). The frequency may vary depending on the area, type of application and the care taken with processing and assembly. The appearance and the consequent effect of dirt on WoodN material vary depending on the cause.

For examples, rain or moisture drops flowing on a surface may concentrate a more visible deposit of dust and dirt. Such residues shall be quickly removed, as they may cause non-homogeneous discoloration of the material.

In outdoor applications, brushed products may present surface rings after being exposed to rainfall and humidity.

This phenomenon, caused by a rising on the surface of tannin, a natural component of any wood fibre, is to be considered normal and will disappear after a few washes with water or after rain. In case of staining, it is advised to remove the stain as soon as possible using water and a neutral detergent (absolutely avoid using abrasive products or solvents, especially acetone).

**Do not use cleaning agents with abrasive or polishing components.** Only use sponges, nylon brushes or cloths. If there is a more serious cleaning issue, it is important to identify the problem before trying to solve it.

After cleaning, rinse very well the residues of any detergent used; the residues may cause an uneven discoloration of the surface.

**WoodN's warranty do not apply in case of improper or incorrect cleaning or handling.**

### Dirt cleaning

Dirt can easily be removed with pressure water. Apply neutral detergent and brush the interested area using a soft nylon brush (or cloth). Rinse plentifully with water paying attention to remove all the residues of detergent from the surface.



# COLOR'S ACCELERATED AGING TEST



#### DISCLAIMER - GENERAL NOTES

Due to conversion from metric sizes and measurements, the US values provided are approximate.

The information provided by WoodN Industries in this document are solely indicative, they are based on the present state of knowledge and must be considered only as a description of our products and their possible application. Such information must not be interpreted as a guarantee of specific features, performances or warranties of the product. Material's colors and finishes represented in this document are the result of printing techniques so they may slightly differ from the original colors. Original samples are available upon request and constitute only a general indication of the dimensions and the aesthetic appearance of Woodn™ profiles. WoodN Industries may change the information included in this document at any time and without further notice. WoodN Industries does not warrant the accuracy and completeness of the information in this document and furthermore their suitability for the purpose which it is consulted for by the other parties. WoodN's customers or third parties must ascertain they have the most recent version of this document, available at [www.woodn.com](http://www.woodn.com). It is advised that customers and third parties have a professional adviser to inform them about the suitability of the products for all desired applications and about applicable laws and regulations. WoodN Industries reserves the right to modify products and concerning features without prior notice. WoodN Industries is not liable for any damage arising from, or related to, the use of this document. Woodn™ material does not have structural characteristics and therefore WoodN Industries declines all responsibilities for improper use of the material. No sections of this publication can be reproduced, stored in database, or transmitted in any form or by any other mean without the explicit approval of WoodN Industries. For more information please contact WoodN Industries.

# ACCELERATED AGING RESISTANCE TEST

## COLOUR STABILITY

Colour stability has been tested in compliance with accelerated weathering tests (UNI EN ISO 4892-2:2009 and UNI EN ISO 2105-A02:1996); the result of the test is expressed by assigning a numerical value to colour variation according to the international greyscale, which is a useful method to measure colors differences.

## PURPOSE OF THE TEST

Resistance to accelerated aging on Woodn profiles according to UNI norms EN ISO 4892-2:2009 and EN 20105-A02:1996.

## TEST METHOD

The equipment used is fitted with a 6500 watt water-cooled Xenon lamp.

The equipment is set according to the following parameters:

- exposure to continuous light
- light source on the samples: 0.05 W/sqft at 340 nm, corresponding to 53.9 W/sqft
- total power exposed to the sample: 0.23 GJ/sqft and 0.70 GJ/sqft
- exposure program: 102 min. of light exposure and 18 min. of light exposure + sprayed deionized water.

sample	color	Greyscale degree* after 3600h of exposure against original samples	Greyscale degree** after 3600h of exposure compared to samples aged for 1200 h
1	Bianco Carrara	3	4/5
2	Lagorai	3	4/5
6	Marrakech	3/4	4/5
9	Cuba	3/4	4/5
10	Caffè Bogotà	4	4
12	Segovia	3	4/5
13	Myanmar	4	4
14	Grigio Silverstone	4	4/5
27	Grigio Lavaredo	2/3	4/5
28	Grigio Londra	3	4/5
33	Beige Sahara	3/4	5

(\*) The international greyscale goes from Grade 1 (maximum colour difference) to Grade 5 (minimum colour difference).

# FINISHES AND COLORS WOODN LINE

## Brushed (for Indoor and Outdoor applications)

01 Bianco Carrara



01-PW Avorio



02 Lagorai



28 Grigio Londra



14 Grigio Silverstone



48 Black



99 Cuba



13 Myanmar



10 Caffè Bogotà



33 Beige Sahara



77 CocoWalk



73 Sinai



80 Terracotta



## Smooth (only for Indoor applications)

01 Bianco Carrara



01-PW Avorio



02 Lagorai

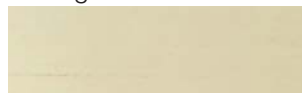

28 Grigio Londra



14 Grigio Silverstone



48 Black



99 Cuba



13 Myanmar



10 Caffè Bogotà

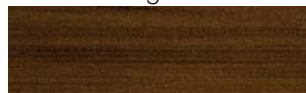

33 Beige Sahara



77 CocoWalk



73 Sinai



80 Terracotta



Colors and textures shown are purely indicative. Check every time a real sample for approval.  
Considering the presence of natural wood fibers, colors may vary from batch to batch.

# FINISHES AND COLORS GREENWOOD LINE

## Solarium (for Indoor and Outdoor applications)

14S Bianco



12S Miele



21S Tabacco



23S Terra di Siena



31S Ebano



32S Wengè

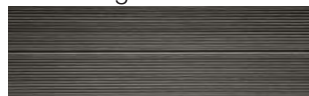

16S Taupe



33S Aubergine



10S Caffè Bogotà

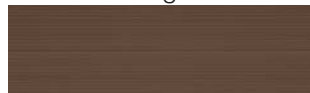

13S Myanmar



## Loft (for Indoor and Outdoor applications)

14L Bianco



12L Miele



21L Tabacco



23L Terra di Siena



31L Ebano



32L Wengè



16L Taupe



33L Aubergine



10L Caffè Bogotà



13L Myanmar



Colors and textures shown are purely indicative. Check every time a real sample for approval.  
Considering the presence of natural wood fibers, colors may vary from batch to batch.



SPECIES UNICA



BORN IN VENICE

SPECIES UNICA



BORN IN VENICE

Headquarter:

Woodn Industries, Via Ippolito Caffi, 17 - 32100 Belluno, ITALY

tel: +39 049 89.60.706

info@woodn.com

Production site:

Woodn Italy, Via delle Industrie, 11 - 30030 Salzano (VE), ITALY

[www.woodn.com](http://www.woodn.com)