



CASAMANIA
HORM

Complementi, Lampade e Outdoor

Awards



2008 / Stand Salone 2005
2004 / Ripples
1998 / Istruzioni di montaggio



2016 / Autoreggente
2011 / Bek
2008 / Tide

2001 / Sottiletto
1998 / Wow! Plus
1998 / Take

1994 / Tola



2014 / Autoreggente
2013 / Infinity
2011 / RememberMe

2008 / N7



2014 / Toshi
2013 / Lepel
2013 / Chariot



2016 / QuaDror™ 03



2012 / Maritime



2016 / Tout le Jour



2016 / Torii



2010 / Lieve
2007 / A/R



2016 / Torii
2015 / Autoreggente
2013 / Chariot
2011 / Sinapsi

2008 / Bek
2008 / A/R
2007 / Blend
2007 / Tide

2006 / Stand Salone 2005
2004 / Ripples
1999 / Sottiletto

Home & Contract

Gli opposti si attraggono. HORM e CASAMANIA hanno da sempre due anime distinte, intrise di pura passione per la ricerca, la qualità, il design. Questo Catalogo rappresenta l'inizio di un progetto: far dialogare questi pluridecennali campioni del Made in Italy, nel solco della loro identità. Horm è lo stile più rigoroso, formale, elegante, caratterizzato dal sapiente uso delle materie pure come il legno, la pietra, il marmo, il vetro. Casamania gioca da sempre con l'ironia, l'irriverenza formale, la voglia di rompere gli schemi nel segno della funzionalità e della ricerca. La prima è sempre stata e continuerà ad essere un'icona di stile e di raffinata eleganza in ambito HOME; la seconda è un modello per il mercato CONTRACT. Tuttavia gli opposti si attraggono, si fondono e si moltiplicano, offrendo infinite soluzioni di stile, di utilizzo, di collocazione. Due identità che unite vogliono rompere le rigide barriere del mercato, ponendo al centro del progetto l'Uomo nelle sue molteplici attività: pensare, sedersi, riposare, mangiare, lavorare, studiare, giocare, dormire, amare, sognare, conversare. Horm e Casamania: Home & Contract.

Vol. 01
Sedute, Tavoli e Tavolini

Vol. 02
Contenitori, Mensole e Librerie

Vol. 03
Complementi, Illuminazione e Outdoor

Vol. 04
Letti, Divani Letto e Isole Figi

Vol. 05
Divani

Opposites attract. HORM and CASAMANIA have always had two different souls, imbued with a pure passion for research, quality and design. This catalogue represents the starting point of a new project: to make these historical champions of the Made in Italy production talk to each other, in the wake of their identity. Horm is the most rigorous, formal, elegant style, characterised by the skilful use of pure materials, such as wood, stone, marble and glass. Casamania has always played with irony, formal irreverence, the desire to break the mould in the name of functionality and research. The first has always been and will continue being an icon of style and refined elegance in the HOME, the second a model for the CONTRACT market. However, opposites attract, merge and multiply, offering infinite solutions of style, use and arrangement. Two identities that together want to break the rigid barriers of the market, placing People in its many activities at the heart of the project: thinking, sitting, resting, eating, working, studying, playing, sleeping, loving, dreaming, talking. Horm and Casamania: Home & Contract.

Vol. 01
Chairs, Tables, and Low Tables

Vol. 02
Storage and Shelving Solutions

Vol. 03
Furnishing Accessories,
Lighting, and Outdoor

Vol. 04
Beds, Sofa Beds, and Figi Islands

Vol. 05
Sofas and Armchairs

Les opposés s'attirent. HORM et CASAMANIA ont toujours eu deux âmes distinctes, imprégnées d'une pure passion pour la recherche, la qualité et le design. Ce catalogue représente le début d'un projet: faire dialoguer ces pluridécennales champions du Made in Italy, dans la lignée de leur identité. Horm représente un style plus rigoureux, formel, élégant, caractérisé par une utilisation habile des matériaux purs comme le bois, la pierre, le marbre et le verre. Casamania a toujours joué avec l'ironie, l'irrévérence formelle, le désir de briser les schémas sous le signe de la fonctionnalité et de la recherche. La première a toujours été et continuera à être une icône de style et d'élégance raffinée dans le domaine HOME, la seconde est un modèle pour le marché CONTRACT. Cependant, les opposés s'attirent, fusionnent et se multiplient, en offrant des solutions infinies de style, d'utilisation et d'emplacement. Deux identités qui, ensemble, veulent briser les rigides barrières du marché, en plaçant l'Homme dans ses nombreuses activités au centre du projet: penser, s'asseoir, se reposer, manger, travailler, étudier, jouer, dormir, aimer, rêver, converser. Horm et Casamania: Home & Contract.

Vol. 01
Chaises, Tables et Tables Basses

Vol. 02
Meubles de rangement, Etagères et Bibliothèques

Vol. 03
Compléments d'ameublement,
Luminaire et Outdoor

Vol. 04
Lits, Canapés-lits et Îles Figi

Vol. 05
Canapés et Fauteuils

Gegensätze ziehen sich an. HORM und CASAMANIA hatten schon immer zwei verschiedene Seelen, durchdrungen von einer reinen Leidenschaft für Forschung, Qualität und Design. Dieser Katalog stellt den Beginn eines Projekts dar: diese jahrzehntelangen Meister des Made in Italy im Zuge ihrer Identität miteinander in Dialog zu bringen. Horm ist der rigoroseste, formalste und eleganteste Stil, der sich durch den geschickten Einsatz von reinen Materialien wie Holz, Stein, Marmor und Glas auszeichnet. Casamania setzte schon immer auf Ironie, formale Respektlosigkeit und den Wunsch, diese Klischees im Namen der Funktionalität und Forschung durchzubrechen. Die erste war und ist eine Ikone des Stils und der raffinierten Eleganz im Bereich HOME, die zweite ein Modell für den CONTRACT-Markt. Gegensätze ziehen sich jedoch an, verschmelzen und multiplizieren sich und bieten unendliche Lösungen für Stil, Nutzung und Anordnung. Zwei Identitäten, die gemeinsam die starren Barrieren des Marktes überwinden wollen, indem sie den Menschen in den Mittelpunkt des Projekts stellen: Denken, Sitzen, Ausruhen, Essen, Arbeiten, Studieren, Spielen, Schlafen, Lieben, Träumen, Sprechen. Horm und Casamania: Home & Contract.

Vol. 01
Stühle, Tische, Couch- und Beistelltische

Vol. 02
Sideboards, Wandregale und Bücherregale

Vol. 03
Kleinformel, Accessoires,
Lampen und Outdoor

Vol. 04
Betten, Bettsofas und Figi-Inseln

Vol. 05
Sofas und Sessel

Los opuestos se atraen. HORM y CASAMANIA siempre han tenido dos almas distintas, imbuidas de pura pasión por la investigación, la calidad y el diseño. Este catálogo representa el comienzo de un proyecto: un diálogo entre estos campeones del Made in Italy, partiendo de la identidad de cada uno de ellos. Horm es el estilo más riguroso, formal y elegante, caracterizado por un uso hábil de materiales puros como la madera, la piedra, el mármol y el vidrio. Casamania siempre ha jugado con la ironía, la irreverencia formal, el deseo de romper moldes en aras de la funcionalidad y la investigación. La primera ha sido siempre y lo seguirá siendo un icono de estilo y refinada elegancia en el ámbito HOME, la segunda es un referente del mercado CONTRACT. Sin embargo, los opuestos se atraen, se fusionan y se multiplican, aportando infinitas soluciones de estilo, uso y ubicación. Dos identidades que quieren romper juntas las rígidas barreras del mercado, colocando en el centro del proyecto al Ser Humano en sus múltiples actividades: pensar, sentarse, descansar, comer, trabajar, estudiar, jugar, dormir, amar, soñar, conversar. Horm y Casamania: Home & Contract.

Vol. 01
Sillas, Mesas y Mesitas

Vol. 02
Aparadores, Estanterías y Librerías

Vol. 03
Complementos de decoración,
Iluminación y Outdoor

Vol. 04
Camas, Sofás Cama e Islas Figi

Vol. 05
Sofás y Sillones

Designers



Baldanzi
& Novelli



Claudio
Bellini



Mario
Bellini



Patrizia
Bertolini



Mario
Botta



Burtcher
& Bertolini



Enrico
Cesana



Claesson
Koivisto
Rune



Carlo
Cumini



Maarten
De Ceulaer



Joe
Doucet



Dror



D'Urbino
Lomazzi



Sebastian
Errazuriz



Fabrica

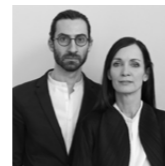

GamFratesi



Daniele
Gaspardo



Jean Francois
Gornée



Grafite
Design



Harry
& Camila



Steven
Holl



Benjamin
Hubert



Giulio
Iacchetti



Salvatore
Indriolo



Toyo
Ito

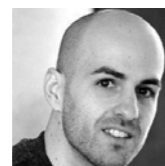

Tobias
Jurczek



LucidiPevere



Giulio
Manzoni



Ilaria
Marelli



Menguzzato
& Nascimben



Neuland,
Paster &
Geldmacher



Luca
Nichetto



Fabio
Novembre



Orlandini
Design



Josh
Owen



Palomba
Serafini
Associati



Pastorino
& Suarez



Jake
Phipps



Marcello
Pozzi



Meneghello
Paoletti
Associati



Pudelskern



Karim
Rashid



Carlo
Stefanut



Stokkeastad



Studio 63



Studio
Balutto



Studio
Habits



Marta
Szymkowiak



Marc
Thorpe



Matteo Thun
& Antonio
Rodriguez



Esa
Vesmanen



Samuel
Wilkinson



Wis
Design



Sean
Yoo



Renato
Zamberlan



StH
Orizzonti
Design
Center

Index

| | | | |
|---------------|---------------------------------|----------|------------------------------|
| 014 | Alberto Appendiabiti | 100 | Vad Impilabile Polipropilene |
| 046 | Alberto Stendibiancheria | 044 | Woodclock |
| 080»086 | Alieno | 022 | Xx |
| 084»088 | Alieno High | 034 | Yume |
| 090, 130 | Alieno Peacock | 036 | Yume Black |
| 024 | Backstage | 014, 042 | Zontik |
| 082 | Bek | | |
| 038 | Cobra | | |
| 112 | Elfo Outdoor | | |
| 032 | Gill | | |
| 066 | Granny | | |
| 016, 030 | Hcb | | |
| 090, 110, 112 | Hexagon | | |
| 092, 094 | Him & Her Opaca | | |
| 018 | Hoo | | |
| 108 | Kant | | |
| 040 | Korzina | | |
| 026 | Mamanonmama | | |
| 048, 118 | Maria | | |
| 104, 128, 132 | Meduse Tavolino | | |
| 122, 124 | Morfino & Morfino Pouf | | |
| 068 | Numero 3 | | |
| 120, 122 | Opus Incertum | | |
| 070 | Plywood Chandelier | | |
| 132, 134 | Pollon | | |
| 060, 062 | Quadror™ Sculpture | | |
| 104 | Raphia Alluminio | | |
| 102 | Raphia Rattan | | |
| 054, 056 | Riddled Buffet | | |
| 058 | Riddled Totem | | |
| 086, 114, 116 | Ripples Outdoor | | |
| 050, 052 | Robox | | |
| 106 | Sin | | |
| 096 | Stereo Impilabile Polipropilene | | |
| 078, 098 | Stereo Metal Polipropilene | | |
| 078»082, 094 | T1 Outdoor | | |
| 072, 074 | Twee T. | | |
| 020 | Twist | | |
| 126»130 | Urban | | |
| 030 | Ute Millerighe | | |
| 028 | Ute Minimal | | |

137 Finiture e materiali
Finishes and materials

154 Legenda dei simboli
Key to symbols

153 Schede tecniche
Technical sheets

Appendiabiti
Coat stands
Porte-manteaux
Garderobenständer
Percheros



Alberto Appendiabiti
014



Hcb
016, 030



Hoo
018



Twist
020



Xx
022

Specchi
Mirrors
Miroirs
Spiegel
Espejos



Backstage
024



Gill
032



Mamanonmama
026



Ute Millerighe
030



Ute Minimal
028



Yume
034



Yume Black
036

Porta TV
TV stands
Meubles TV
TV-Möbel
Muebles TV



Cobra
038

Gettacarte
Waste paper baskets
Corbeilles à papier
Papierkörbe
Papeleras



Korzina
040

Portaombrelli
Umbrella stands
Porte-parapluies
Schirmständer
Paragüeros



Zontik
014, 042

Orologi da muro
Wall clocks
Horloges murales
Wanduhren
Relojes de pared



Woodclock
044

Stendibiancheria
Clothesline
Etendoirs à linge
Wäscheständer
Tendederos



Alberto Stendibiancheria
046

Oggetti decorativi
Decorative objects
Objets décoratifs
Dekorative Objekte
Objetos decorativos



Maria
048, 118

Sculture domestiche
Domestic sculptures
Sculptures pour l'habitat
Wohnskulpturen
Esculturas domésticas

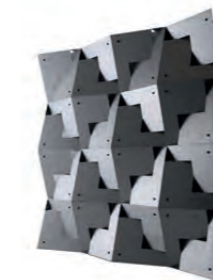

QuaDror™ Sculpture
060, 062

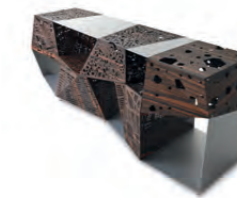

Riddled Buffet
054, 056



Riddled Totem
058



Robox
050, 052

Illuminazione
 Lighting
 Luminaire
 Lampen
 Iluminación



Granny
066



Numero 3
068



Plywood Chandelier
070



Twee T.
072, 074



Alberto Stendibiancheria
046



Alieno, Alieno High & Alieno Peacock
080, 084, 086, 088, 090, 130

Outdoor



Bek
082



Elfo Outdoor
112



Hexagon
90, 110, 112



Him & Her Opaca
092, 094



Kant
108



Maria
048, 118



Meduse Tavolino
104, 128, 132



Morfino & Morfino Pouf
122, 124

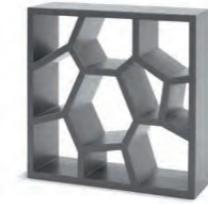

Opus Incertum
120, 122



Pollon
132, 134



Raphia Alluminio
104



Raphia Rattan
102



Ripples Outdoor
086, 114, 116



Sin
106



Stereo Impilabile Polipropilene
096



Stereo Metal Polipropilene
078, 098



T1 Outdoor
078, 080, 082, 094



Urban
126, 128, 130



Vad Impilabile Polipropilene
100



Zontik & Korzina
014, 040, 042

Complementi d'arredo
Furnishing Accessories
Compléments d'ameublement
Kleinformel und Accessoires
Complementos de decoración

Alberto Appendiabiti

appendiabiti / coat stand
 CASAMANIA / Fabrica, 2005
 » technical info p. 155



Zontik

portaombrelli / umbrella stand
 CASAMANIA / Karim Rashid, 2006
 » technical info p. 183



J-Table
 scrivania / desk
 vol. 01

Hcb

appendiabiti / coat stand
 HORM / Patrizia Bertolini, 2006
 » [technical info p. 161](#)



Bahamas Alto Legno
 letto / bed
 vol. 04

Hoo

appendiabiti / coat stand
CASAMANIA / Pastorino & Suarez, 2005
» [technical info p. 163](#)

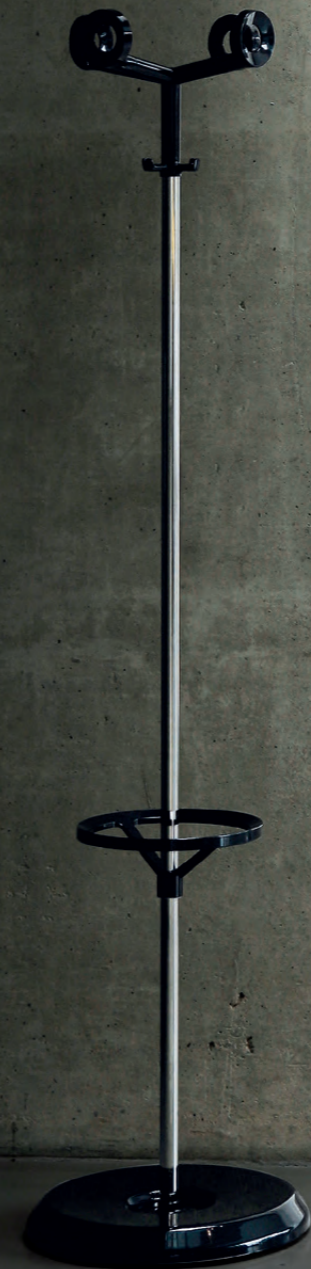

Twist

appendiabiti / coat stand
HORM / Burtcher & Bertolini, 1997
» [technical info p. 176](#)



Twine Tavolino
tavolino / side table
vol. 01

Xx

appendiabiti / coat stand
CASAMANIA / Josh Owen, 2006
» technical info p. 181



Backstage

specchio e contenitore multiuso / mirror and multiuse shelf organizer
HORM / Salvatore Indriolo, 2010
» [technical info p. 157](#)



Mamanonmama

specchio / mirror
HORM / Mario Botta, 2004
» technical info p. 164



Blend
armadio / wardrobe
vol. 02

lo & Te
comodino / night stand
vol. 01

Ute Minimal

specchio / mirror
HORM / SH, 1999
» [technical info p. 179](#)



Ute Millerighe

specchio / mirror
HORM / SH, 1999
» [technical info p. 178](#)



Hcb

appendiabiti / coat stand
HORM / Patrizia Bertolini, 2006
» [technical info p. 161](#)



Gill

specchio / mirror
 HORM / Daniele Gaspardo & SH, 2003
 » technical info p. 160



Anish Cassettiera
 cassettiera / chest of drawers
 vol. 02

Yume

specchio / mirror
HORM / SH, 2011
» [technical info p. 182](#)



Yume Black

specchio / mirror
 HORM / SH, 2011
 » technical info p. 182



Bifronte
 tavolino / side table
 vol. 01

Cobra

porta TV / TV stand
HORM / Mario Bellini, 2006
» [technical info p. 159](#)



Korzina

gettacarte / wastepaper basket
 CASAMANIA / Karim Rashid, 2006
 » [technical info p. 164](#)



Vad Girevole Imbottita
 sedia con braccioli / chair with armrests
 vol. 01

Zontik

portaombrelli / umbrella stand
CASAMANIA / Karim Rashid, 2006
» [technical info p. 183](#)



Woodclock

orologio a parete / wall-mounted clock
HORM / Carlo Stefanut, 2013
» [technical info p. 181](#)



Bahamas Alto Legno
letto / bed
vol. 04

Alberto Stendibiancheria

stendibiancheria / clothesline
CASAMANIA / Fabrica, 2005
» [technical info p. 155](#)



Alberto Stendibiancheria



Maria

oggetto decorativo / decorative object
CASAMANIA / Luca Nichetto, 2007
» [technical info p. 165](#)



Maria



Robox

scultura domestica / domestic sculpture
CASAMANIA / Fabio Novembre, 2011
» [technical info p. 172](#)



Robox

scultura domestica / domestic sculpture
CASAMANIA / Fabio Novembre, 2011
» technical info p. 172



Riddled Buffet

scultura domestica / domestic sculpture
HORM / Steven Holl, 2006
» [technical info p. 170](#)



Riddled Buffet

scultura domestica / domestic sculpture

HORM / Steven Holl, 2006

» [technical info p. 170](#)

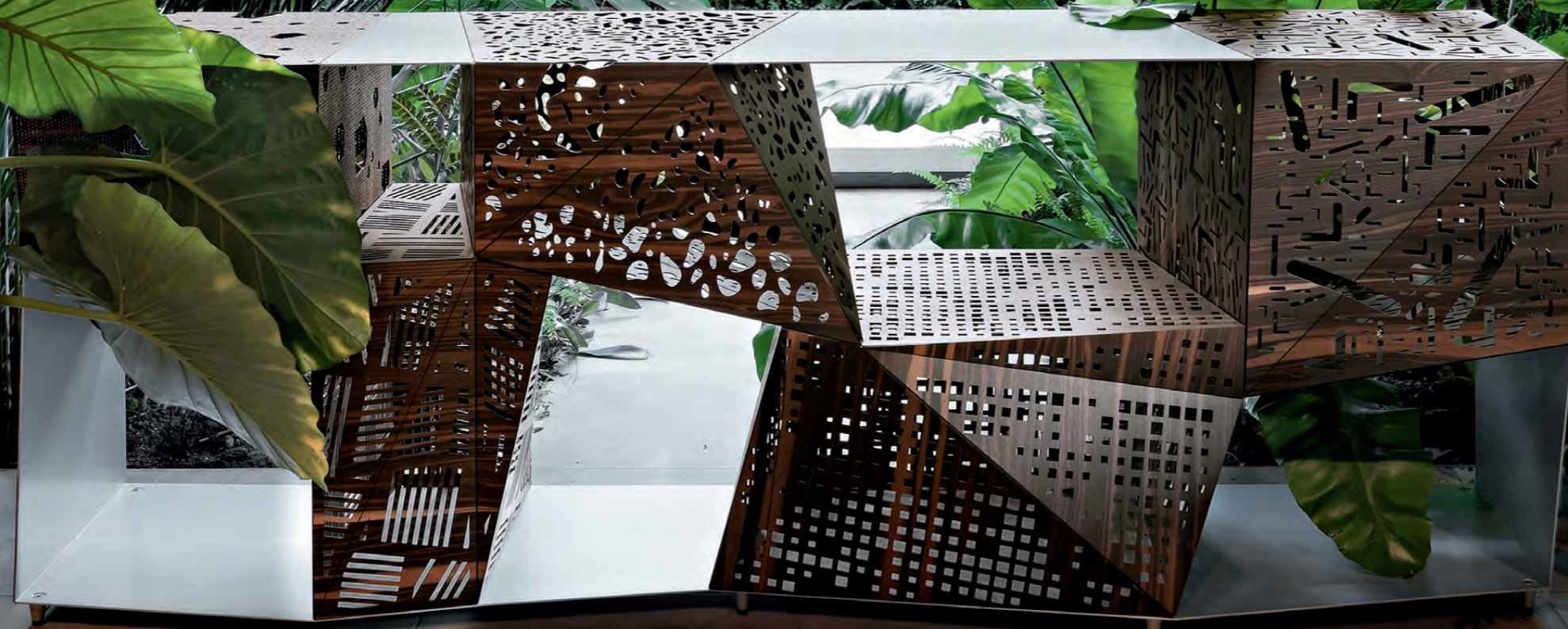

Riddled Totem

scultura domestica / domestic sculpture

HORM / Steven Holl, 2006

» [technical info p. 171](#)



QuaDror™ Sculpture

scultura domestica / domestic sculpture
HORM / Dror, 2015
» technical info p. 168



QuaDror™ Sculpture

scultura domestica / domestic sculpture

HORM / Dror, 2015

» technical info p. 168

Torii
tavolino / coffee table
vol. 01

Tout le Jour Lounge
lounge / lounge chair
vol. 01

Iluminazione

Lighting

Luminaire

Lampen

Iluminación

Granny

lampadario / suspension lamp
CASAMANIA / Pudelskern, 2010 – 2012
» technical info p. 161



Alieno High
sedia / chair
vol. 01

Alieno Peacock
lounge / lounge chair
vol. 01

Numero 3

lampada da terra / floor lamp
HORM / Patrizia Bertolini, 2013
» technical info p. 166



Figi Isolotto
divano letto / sofa bed
vol. 04



Plywood Chandelier

lampadario / suspension lamp
HORM / Steven Holl, 2011
» [technical info p. 167](#)



Twee T.

lampadario / suspension lamp
CASAMANIA / Jake Phipps, 2014
» [technical info p. 176](#)



Twee T.

lampadario / suspension lamp
 CASAMANIA / Jake Phipps, 2014
 » technical info p. 176



Soho
 poltrona / armchair
 vol. 01

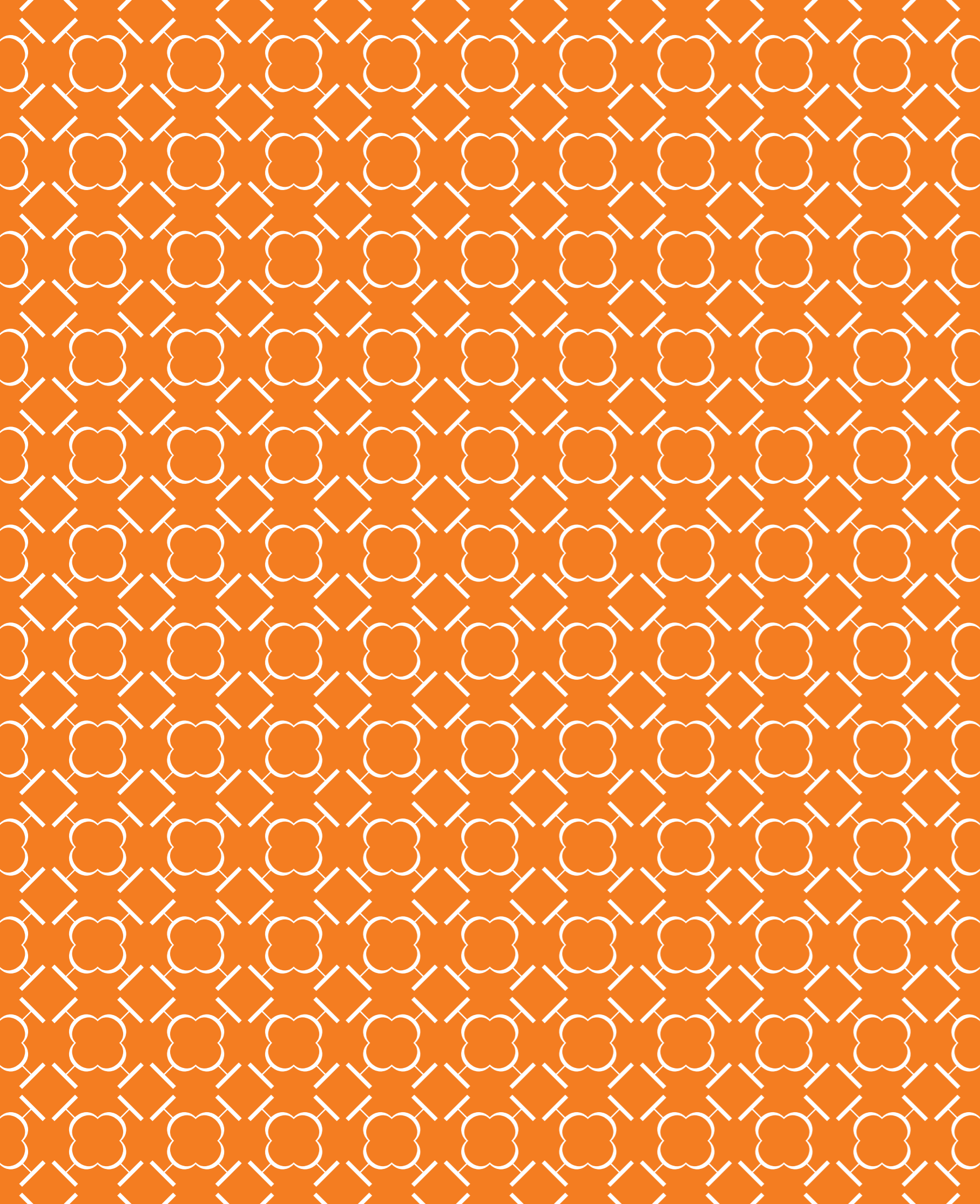

Outdoor

T1 Outdoor

tavolino da bistrot / cafe bar table
 CASAMANIA / STH, 2010 – 2015
 » [technical info p. 175](#)



T1
 acciaio 316 / steel 316



T1
 acciaio 304 / steel 304



Stereo Metal



Stereo Metal Polipropilene

sedia / chair
 CASAMANIA / Luca Nichetto, 2015
 » [technical info p. 175](#)



Alieno

sedia / chair
CASAMANIA / GamFratesi, 2009 – 2015
» [technical info p. 156](#)

T1 Outdoor

tavolino da bistrot / cafe bar table
CASAMANIA / S1H, 2010 – 2015
» [technical info p. 175](#)



T1
acciaio 316 / steel 316



T1
acciaio 304 / steel 304



Alieno



Bek

sedia pieghevole / folding chair
 CASAMANIA / Giulio Iacchetti, 2007
 » [technical info p. 158](#)



Bek



T1
 acciaio 316 / steel 316



T1
 acciaio 304 / steel 304



T1 Outdoor

tavolino da bistrot / cafe bar table
 CASAMANIA / SIH, 2010 – 2015
 » [technical info p. 175](#)



Alieno & Alieno High

sedia / chair
CASAMANIA / GamFratesi, 2009 – 2015
» technical info p. 156



Alieno



Alieno

sedia / chair
CASAMANIA / GamFratesi, 2009 – 2015
» technical info p. 156



Alieno & Alieno High

sedia / chair
CASAMANIA / GamFratesi, 2009 – 2015
» [technical info p. 156](#)

Ripples Outdoor

panca / bench
HORM / SH – homage to Toyo Ito, 2011
» [technical info p. 170](#)



Alieno

Ripples Outdoor



Alieno High

sedia / chair
CASAMANIA / GamFratesi, 2009 – 2015
» [technical info p. 156](#)



Alieno



Alieno Peacock

lounge / lounge chair
CASAMANIA / GamFratesi, 2009 – 2015
» technical info p. 156



Alieno



Hexagon



Hexagon

tavolino / side table
HORM / Steven Holl, 2011
» technical info p. 162



Him & Her *Opaca*

sedia / chair
CASAMANIA / Fabio Novembre, 2008
» [technical info p. 162](#)



Him & Her



T1 Outdoor

tavolino da bistrot / cafe bar table
CASAMANIA / SHH, 2010 - 2015
» [technical info p. 175](#)

Him & Her Opaca

sedia / chair
CASAMANIA / Fabio Novembre, 2008
» [technical info p. 162](#)



T1
acciaio 316 / steel 316



T1
acciaio 304 / steel 304



Him & Her



Stereo Impilabile *Polipropilene*

sedia / chair
CASAMANIA / Luca Nichetto, 2008
» [technical info p. 174](#)



Stereo Impilabile
gambe verniciate / varnished legs



Stereo Impilabile
gambe cromate / chromed legs



Stereo Metal *Polipropilene*

sedia / chair
CASAMANIA / Luca Nichetto, 2015
» [technical info p. 175](#)



Stereo Metal



Meduse Tavolo
tavolo / table
vol. 01

Vad Impilabile Polipropilene

sedia / chair
CASAMANIA / Luca Nichetto, 2009
» [technical info p. 180](#)



Vad Impilabile
gambe verniciate / varnished legs



Vad Impilabile
gambe cromate / chromed legs



Raphia Rattan

sedia con braccioli / chair with armrests
 CASAMANIA / LucidiPevere, 2013
 » [technical info p. 169](#)



Raphia Rattan



Raphia Alluminio

sedia con braccioli / chair with armrests
CASAMANIA / LucidiPevere, 2018
» [technical info p. 169](#)



Raphia Alluminio



Meduse Tavolino

tavolino / side table
CASAMANIA / GamFratesi, 2009
» [technical info p. 165](#)



Meduse Tavolino



Sin

sedia / chair
HORM / SH, 1995
» technical info p. 173



Sin



Kant

sgabello / stool
CASAMANIA / Karim Rashid, 2006
» [technical info p. 163](#)



Kant



Hexagon

sgabello / stool
HORM / Steven Holl, 2011
» [technical info p. 162](#)



Hexagon

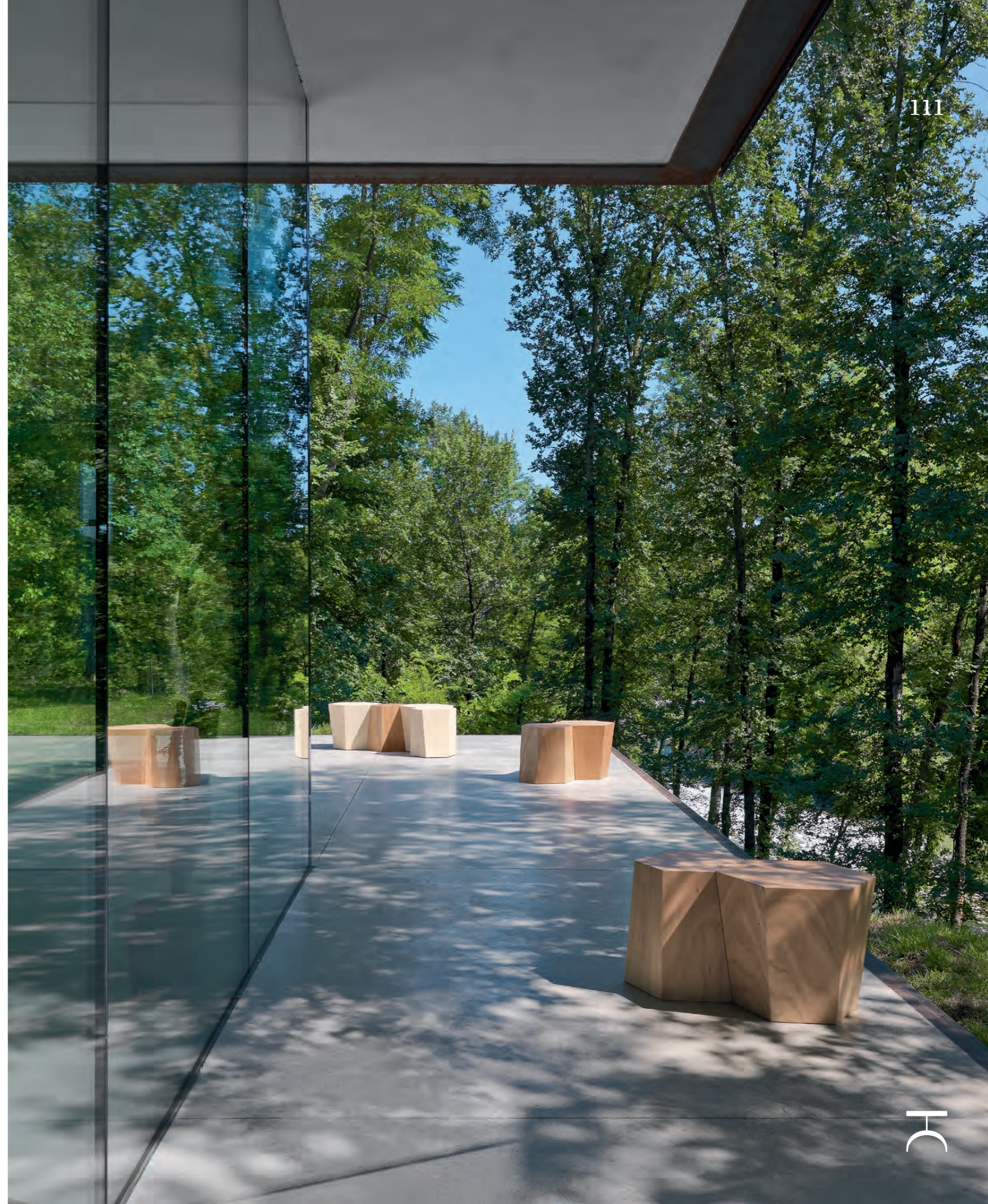

Elfo Outdoor

bean bag / bean bag
HORM / Ilaria Marelli, 2012
» [technical info p. 159](#)



Elfo



Hexagon



Hexagon

sgabello o tavolino / stool or side table
HORM / Steven Holl, 2011
» [technical info p. 162](#)



Ripples Outdoor

panca / bench
HORM / SHH - homage to Toyo Ito, 2011
» [technical info p. 170](#)



Ripples Outdoor



Ripples Outdoor

panca / bench
HORM / SHH – homage to Toyo Ito, 2011
» [technical info p. 170](#)



Ripples Outdoor



Maria

oggetto decorativo / decorative object
 CASAMANIA / Luca Nichetto, 2007
 » [technical info p. 165](#)



Maria



Opus Incertum

contenitore multiuso / multiuse shelf organizer

CASAMANIA / Sean Yoo, 2005

» [technical info p. 167](#)

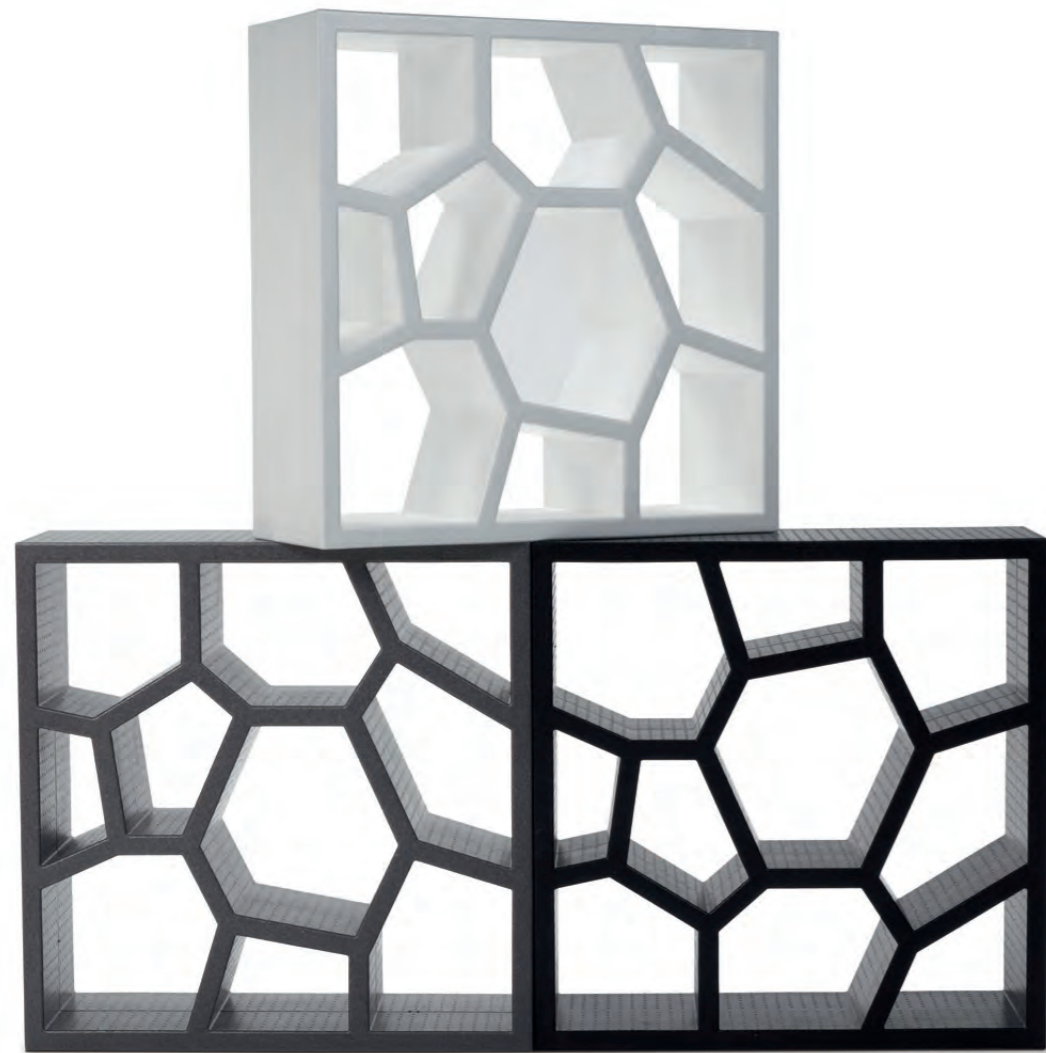

Opus Incertum



Morfino & Morfino Pouf

bean bag e pouf / bean bag and ottoman
CASAMANIA / SIH, 2005
» technical info p. 166



Morfino & Morfino Pouf



Opus Incertum



Opus Incertum

contenitore multiuso / multiuse shelf organizer
CASAMANIA / Sean Yoo, 2005
» technical info p. 167

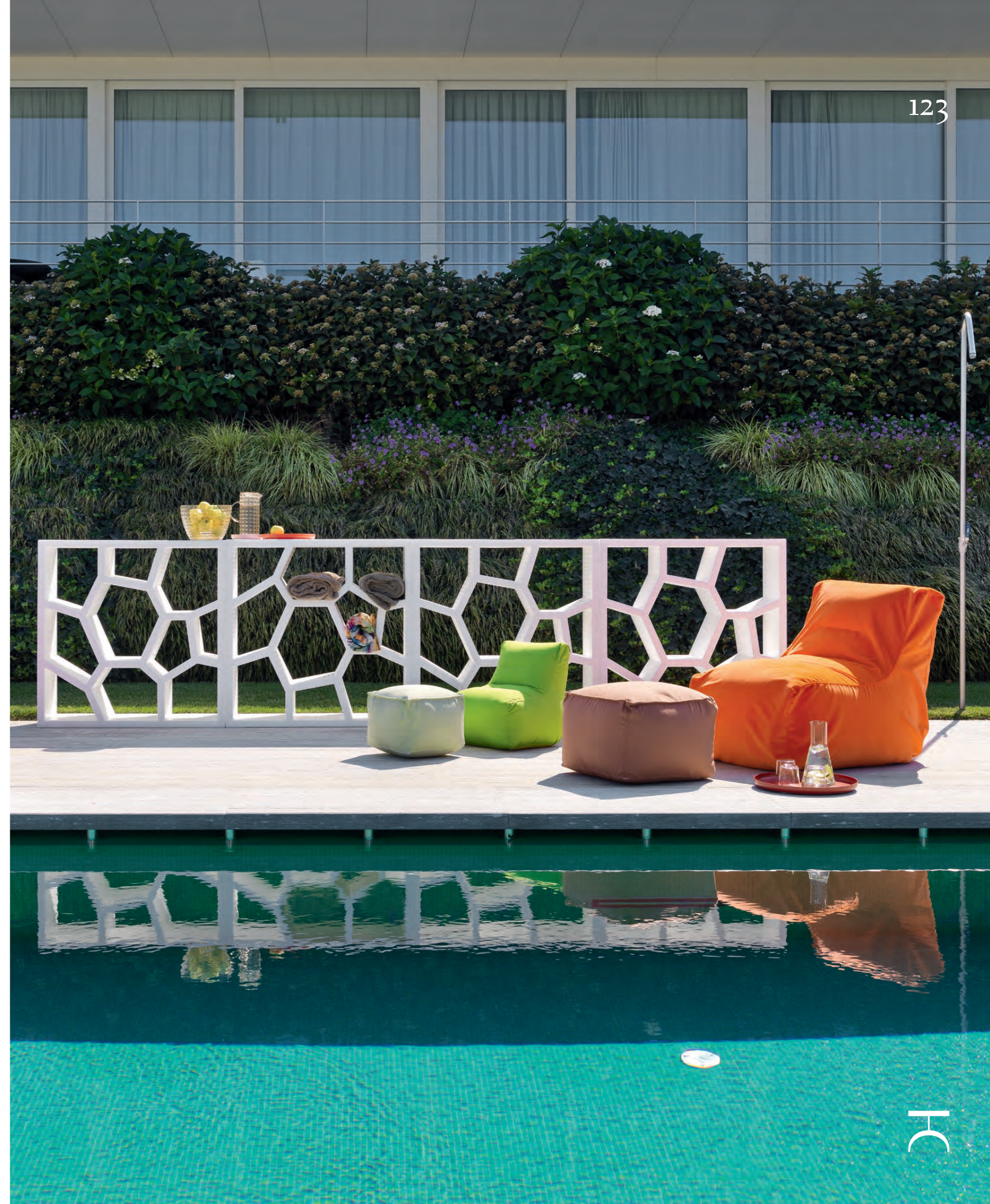

Morfino & Morfino Pouf

bean bag e pouf / bean bag and ottoman
CASAMANIA / SH, 2005
» [technical info p. 166](#)



Urban

contenitore multiuso / multiuse shelf organizer

CASAMANIA / Claudio Bellini, 2009

» [technical info p. 177](#)



Urban



Meduse Tavolino

tavolino / side table
CASAMANIA / GamFratesi, 2009
» [technical info p. 165](#)



Meduse Tavolino



Urban

panca / bench
CASAMANIA / Claudio Bellini, 2009
» [technical info p. 177](#)



Urban



Urban

contenitore multiuso / multiuse shelf organizer
 CASAMANIA / Claudio Bellini, 2009
 » [technical info p. 177](#)

Alieno Peacock

lounge / lounge chair
 CASAMANIA / GamFratesi, 2009 – 2015
 » [technical info p. 156](#)

Urban



Alieno



Pollon

pouf / ottoman
CASAMANIA / STH, 2005
» technical info p. 168



Pollon



Meduse Tavolino

tavolino / side table
CASAMANIA / GamFratesi, 2009
» technical info p. 165



Meduse Tavolino



Pollon

pouf / ottoman
CASAMANIA / SIH, 2005
» technical info p. 168



Pollon



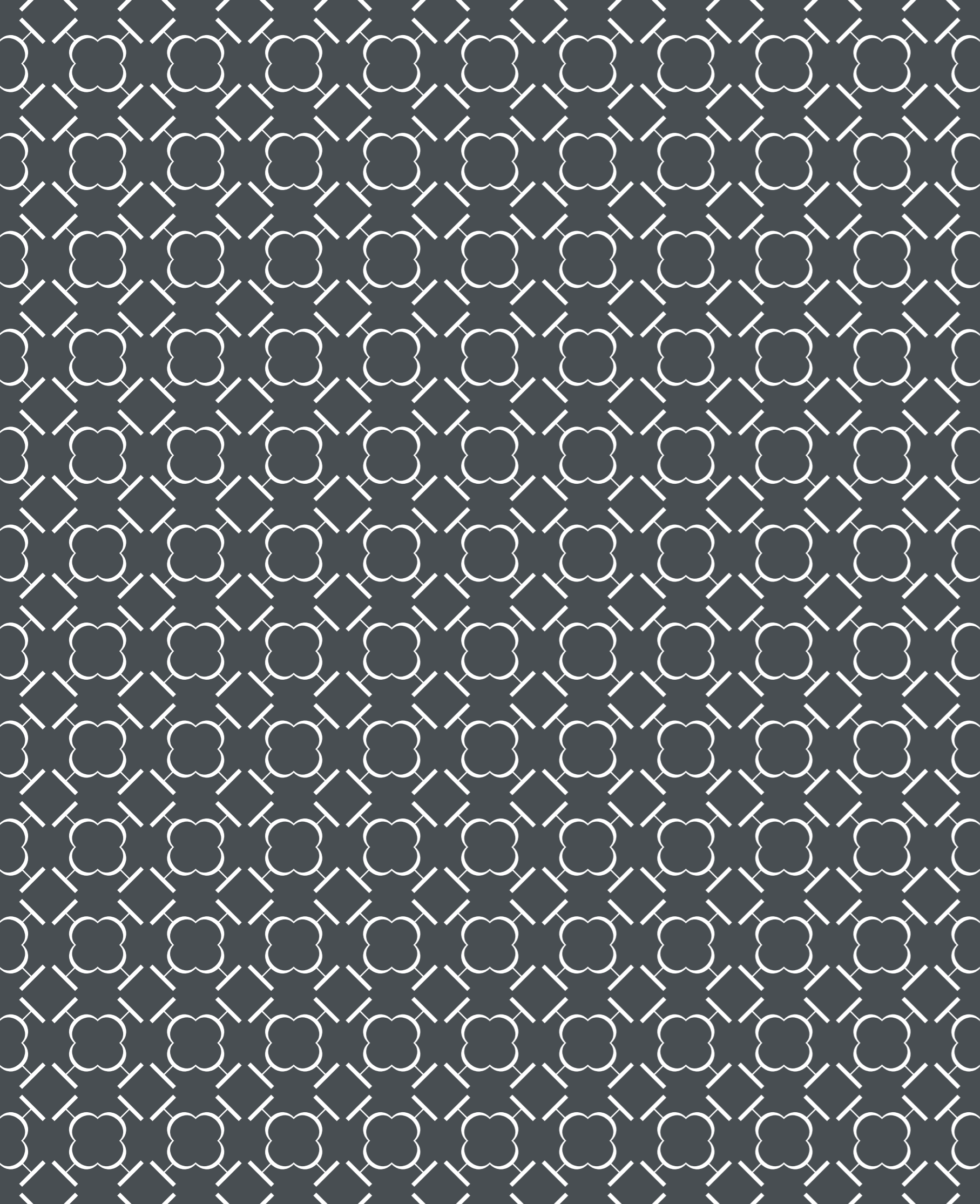

Finiture e materiali
Finishes and materials
Finitions et matériaux
Ausführungen und Materialien
Acabados y materiales

faggio imbiancato
whitened beech
hêtre blanchi
Buche geweißt
haya blanqueada



Cherish / Hcb /
Leon Wood / Ray Sedia /
Spectro / Twist

faggio naturale
natural beech
hêtre naturel
Buche Natur
haya natural



Cherish / Twist

faggio bois blond
bois blond beech
hêtre bois blond
Buche Bois Blond
haya bois blond



Hcb / Leon Wood /
Spectro / Twist

faggio mocha
mocha beech
hêtre moka
Buche Mokka
haya mocha



Anish / Carlos / Cherish /
Hcb / Leon Wood / Pressious /
Ray Sedia / Spectro / Twist

frassino nero
black ash
frêne noir
Esche Schwarz
fresno negro



Carnaby / Ki / Milady /
Pablita / Sienna / Soho /
Velasca

rovere bianco
white oak
chêne blanc
Eiche Weiß
roble blanco



Andaman / Chariot /
Meduse Tavolo / Moheli / Xx

rovere naturale
natural oak
chêne naturel
Eiche Natur
roble natural

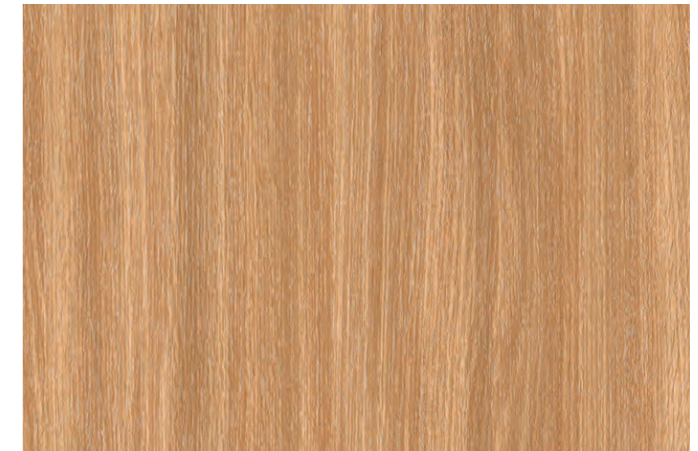

Alberto Appendiabiti / Albino Family / Autoreggente Tavolo /
Bolero / Capriata / Chariot / Cobra / Giro Tavolino /
J – Table / Leon Decor / Lily / Maritime / Meduse Tavolo /
Ray Poltroncina & Sedia / Solaio Armadio & Libreria / Sottiletto /
Stereo Wood / Tango / Twine / Twine Tavolino / Vad Wood /
Woodclock / Wow! Plus / Xx

frassino bianco
white ash
frêne blanc
Esche Weiß
fresno blanco



Ki

frassino tinto rovere
oak-stained ash
frêne teinté chêne
eichefarbig gebeizt Esche
fresno teñido roble



La Dina / Milady /
Velasca

frassino beige
beige grey ash
frêne gris beige
Esche Beigegrau
fresno gris beige



Carnaby / La Dina /
Milady / Velasca

frassino mocha
mocha ash
frêne moka
Esche Mokka
fresno mocha



La Dina / Ma.Re /
QuaDror 01 / QuaDror 03 /
QuaDror 04

rovere beige
beige grey oak
chêne gris beige
Eiche Beigegrau
roble gris beige



Maritime

rovere mocha
mocha oak
chêne moka
Eiche Mokka
roble mocha



Andaman / Barbara /
Capriata / Chariot / Cobra /
Maritime / Meduse Tavolo /
Moheli / Solaio Armadio &
Libreria / Sottiletto /
Twine Tavolino / Xx

noce canaletto
walnut
noyer
Nussbaum
nogal

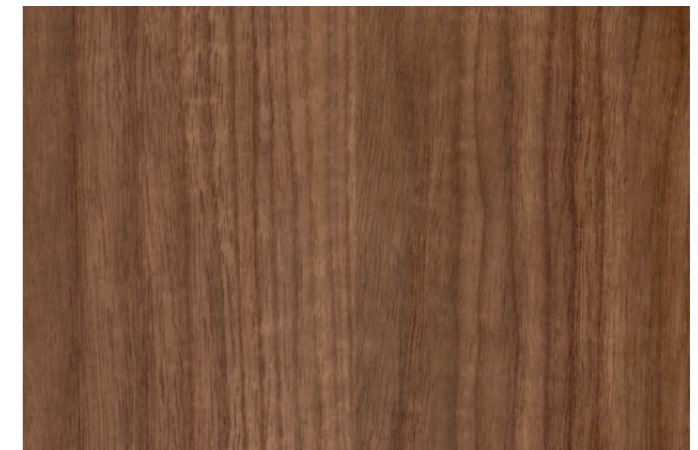

93 – 08 / Albino Family / Albino Torcia / Anish /
Autoreggente / Barbara / Bifronte / Bolero / Bureau / Cobra /
Flower / Ginevra / Io e Te / J – Table / Ki / Leon Decor /
Lily / Meduse Tavolo / Numero 3 / Ray Poltroncina & Sedia /
Singles / Sottiletto / Stereo Wood / Tango / Tribeca / Tutù /
Twine / Twine Tavolino / Vad Wood / Wow! Plus / Woodclock

okumé
okoume
okumé
Okume
ocume

ontano + noce canaletto
alder + walnut
aulne + noyer
Erle + Nussbaum
aliso + nogal

nero-bianco
black-white
noir-blanc
Schwarz-Weiß
negro-blanco

salice nero
black willow
saule noir
Weide Schwarz
sauce negro



Hexagon / Ripples Outdoor



Sendai / Sendai Crystal



Sudoku



Mamanonmama

legno origami in noce canaletto — brevetto HORM
origami wood in walnut — HORM patent
bois origami en noyer — brevet HORM
Origami-Nussbaum — HORM-Patent
madera origami de nogal — patente HORM

legno origami in ebano — brevetto HORM
origami wood in ebony — HORM patent
bois origami en ébène — brevet HORM
Origami-Ebenholz — HORM-Patent
madera origami de ébano — patente HORM



Not Riddled / Plywood Chandelier / Riddled Front / Riddled Table / Riddled Totem

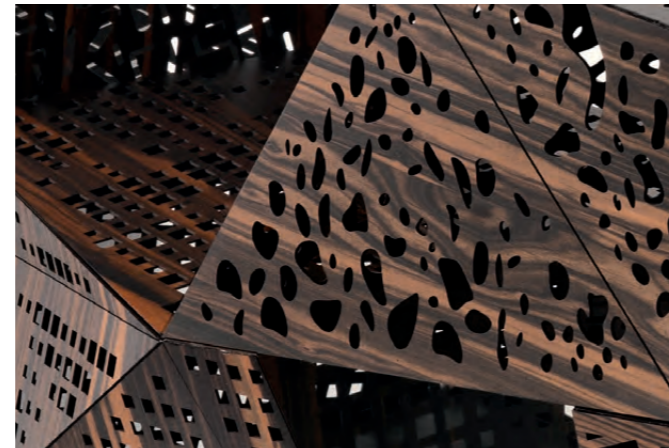

Riddled Buffet

rovere termotrattato + HPL bianco
thermo-treated oak + white HPL
chêne thermotraité + HPL blanc
wärmebehandelte Eiche + HPL Weiß
roble termotrattado + HPL blanco

noce canaletto / mogano / ciliegio / rovere / frassino
walnut / mahogany / cherry / oak / ash
noyer / acajou / cerisier / chêne / frêne
Nussbaum / Mahagoni / Kirsche / Eiche / Esche
nogal / caoba / cerezo / roble / fresno

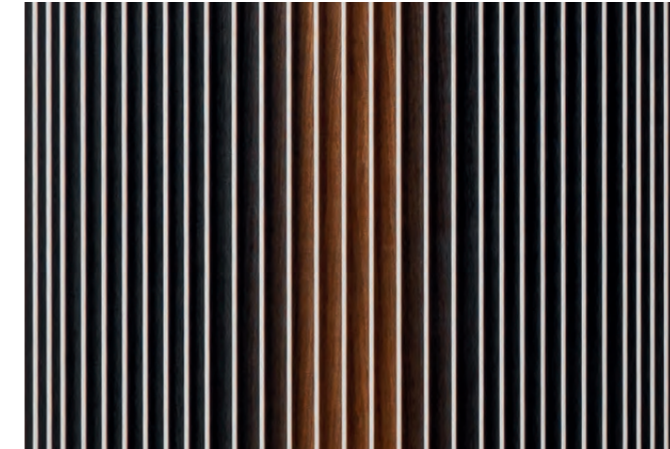

Carlos



Bifronte / ComRi / Ripples / Ripples — Like a River / Ripples Sgabello / Ripples Tavolo

faggio imbiancato / faggio moca / faggio naturale
whitened beech / mocha beech / natural beech
hêtre blanchi / hêtre moka / hêtre naturel
Buche geweißt / Buche Mokka / Buche Natur
haya blanqueada / haya moca / haya natural

faggio imbiancato / faggio bois blond / arancio / giallo
whitened beech / bois blond beech / orange / yellow
hêtre blanchi / hêtre bois blond / orange / jaune
Buche geweißt / Buche Bois Blond / Orange / Gelb
haya blanqueada / haya bois blond / naranja / amarillo

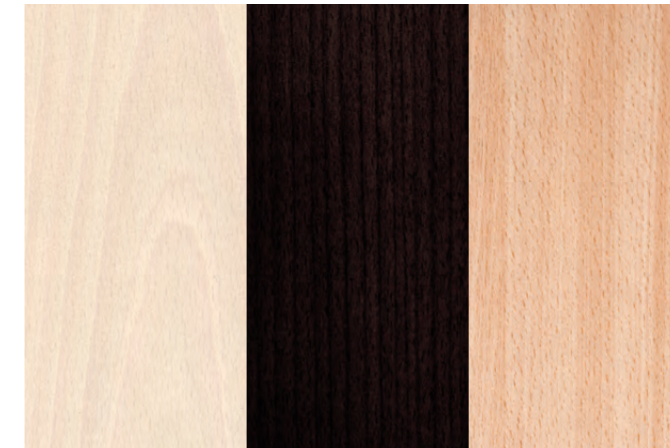

Twist Tricolor



Twist Multicolor

Colori RAL per laccati opachi, metalli e plastiche^(*) / RAL Colors for matt lacquers, metals and plastic^(*)

nero
black
noir
Schwarz
negro



Vedi schede tecniche
See technical sheets
Voir les fiches techniques
Siehe technische Datenblätter
Ver fichas técnicas

bianco
white
blanc
Weiß
blanco

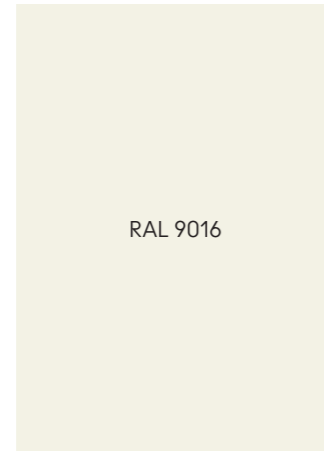

Vedi schede tecniche
See technical sheets
Voir les fiches techniques
Siehe technische Datenblätter
Ver fichas técnicas

polvere
dusty grey
gris poussière
Staubgrau
gris polvo



Vedi schede tecniche
See technical sheets
Voir les fiches techniques
Siehe technische Datenblätter
Ver fichas técnicas

beige
beige grey
gris beige
Beigegrau
gris beige



Vedi schede tecniche
See technical sheets
Voir les fiches techniques
Siehe technische Datenblätter
Ver fichas técnicas

rosso vino
wine red
rouge vin
Weinrot
rojo vino



Vedi schede tecniche
See technical sheets
Voir les fiches techniques
Siehe technische Datenblätter
Ver fichas técnicas

bruno
brown grey
gris brun
Braungrau
gris parduzco



Vedi schede tecniche
See technical sheets
Voir les fiches techniques
Siehe technische Datenblätter
Ver fichas técnicas

grafite
graphite
graphite
Graphit
grafito

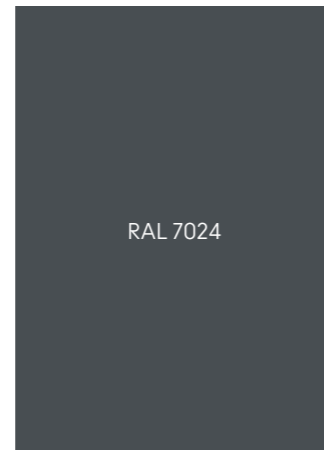

Vedi schede tecniche
See technical sheets
Voir les fiches techniques
Siehe technische Datenblätter
Ver fichas técnicas

rosso chiaro brillante
luminous bright red
rouge clair brillant
Leuchthellrot
rojo claro brillante



Chariot

Laccati lucidi / Glossy lacquers

nero
black
noir
Schwarz
negro



Vedi schede tecniche
See technical sheets
Voir les fiches techniques
Siehe technische Datenblätter
Ver fichas técnicas

bianco
white
blanc
Weiß
blanco

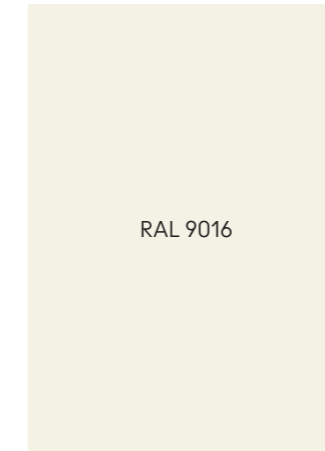

Vedi schede tecniche
See technical sheets
Voir les fiches techniques
Siehe technische Datenblätter
Ver fichas técnicas

polvere
dusty grey
gris poussière
Staubgrau
gris polvo



Vedi schede tecniche
See technical sheets
Voir les fiches techniques
Siehe technische Datenblätter
Ver fichas técnicas

beige
beige grey
gris beige
Beigegrau
gris beige

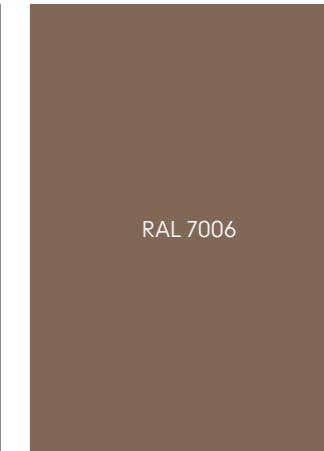

Vedi schede tecniche
See technical sheets
Voir les fiches techniques
Siehe technische Datenblätter
Ver fichas técnicas

rosso vino
wine red
rouge vin
Weinrot
rojo vino



Vedi schede tecniche
See technical sheets
Voir les fiches techniques
Siehe technische Datenblätter
Ver fichas técnicas

bruno
brown grey
gris brun
Braungrau
gris parduzco



Vedi schede tecniche
See technical sheets
Voir les fiches techniques
Siehe technische Datenblätter
Ver fichas técnicas

grafite
graphite
graphite
Graphit
grafito

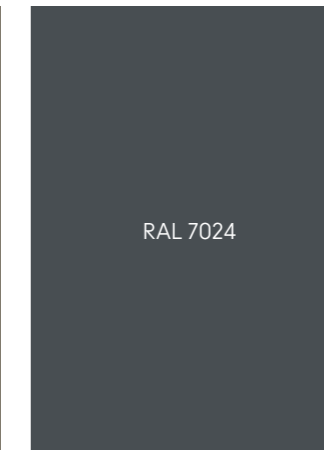

Vedi schede tecniche
See technical sheets
Voir les fiches techniques
Siehe technische Datenblätter
Ver fichas técnicas

(*)

Polypropylene / Polyethylene / Polyamide

brunito
burnished
bruni
Brüniert
bruñido



Basamento Mid-Century
Modern

crudo
crude
cru
Roh
crudo

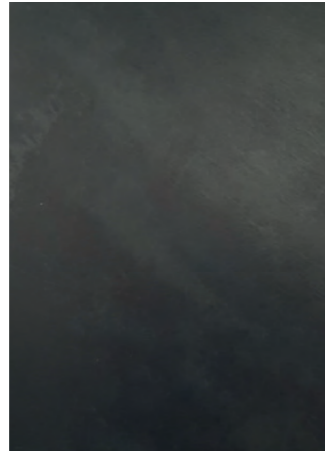

QuaDror 01 / QuaDror 02 /
Torii

verniciato bronzo antico
antique bronze painted
verni bronze antique
Vintage Bronze beschichtet
pintado de bronce antiguo



Meduse Tavolo / Network

verniciato oro
gold painted
verni or
Gold beschichtet
pintado de oro



Chariot

cromato
chromed
chromé
Chrom
cromado



Bar / Sin / Stereo Impilabile /
T2 / Vad Girevole /
Vad Impilabile

cromo nero
black chrome
chrome noir
Schwarz Chrom
cromo negro



Albino Family

marmo Carrara
Carrara marble
marbre Carrara
Carrara Marmor
mármol Carrara



Albino Family / Flower /
Lily / Meduse Tavolo

marmo Emperador
Emperador marble
marbre Emperador
Emperador Marmor
mármol Emperador

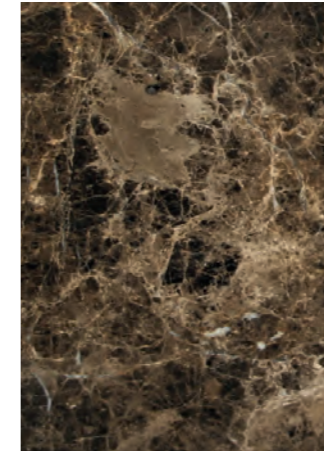

Albino Family / Barbara /
Lily / Meduse Tavolo /
Tout le Jour Tavolino

marmo Marquina
Marquina marble
marbre Marquina
Marquina Marmor
mármol Marquina

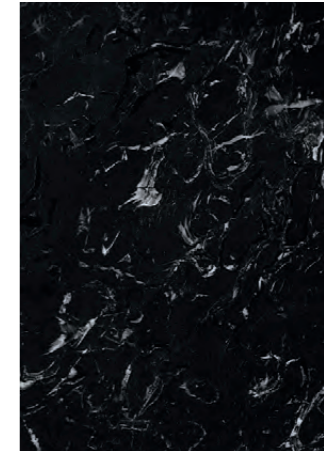

Albino Family / Barbara /
Flower / Lily / Meduse
Tavolo / Tout le Jour Tavolino

pietra leccese
Lecce limestone
pierre de Lecce
Lecce-Stein
piedra de Lecce



Hexagon

ceramica grigia
grey ceramic
céramique gris
graue Keramik
cerámica gris



Ma.Re / Torii

cemento
concrete
béton
Beton
hormigón



Barbara

bianco
white
blanc
Weiß
blanco



Maria

bordeaux
bordeaux
bordeaux
bordeaux

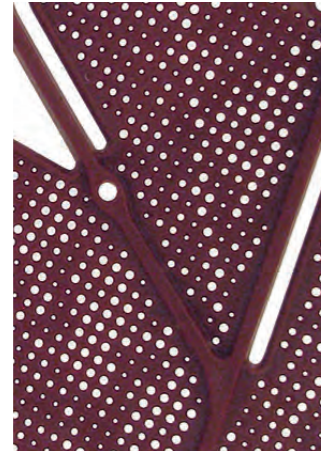

Maria

verde scuro
dark green
vert foncé
Dunkelgrün
verde oscuro

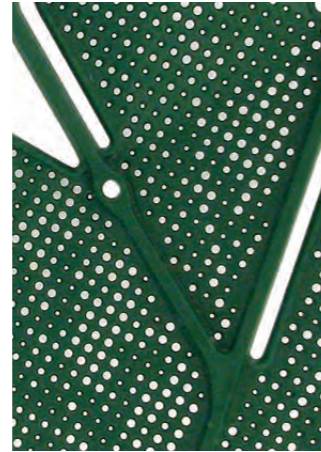

Maria

verde chiaro
light green
vert clair
Lichtgrün
verde claro



Maria

p. espanso nero
expanded p. black
p. expansé noir
expandiertes P. Schwarz
p. expandido negro

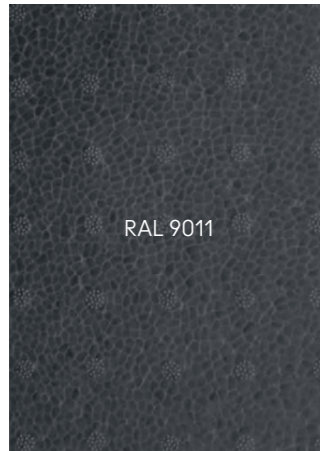

Opus Incertum

p. espanso bianco
expanded p. white
p. expansé blanc
expandiertes P. Weiß
p. expandido blanco



Opus Incertum

p. espanso polvere
expanded p. dusty grey
p. expansé gris poussière
expandiertes P. Staubgrau
p. expandido gris polvo



Opus Incertum

p. espanso beige
expanded p. beige grey
p. expansé gris beige
expandiertes P. Beigegräu
p. expandido gris beige



Opus Incertum

nero
black
noir
Schwarz
negro



RAL 9011

Him & Her Lucida /
Korzina / Zontik

bianco
white
blanc
Weiß
blanco

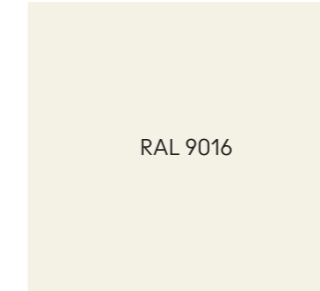

RAL 9016

Him & Her Lucida

polvere
dusty grey
gris poussière
Staubgrau
gris polvo



RAL 7037

Him & Her Lucida /
Korzina / Zontik

beige
beige grey
gris beige
Beigegräu
gris beige



RAL 7006

Him & Her Lucida /
Korzina / Zontik

rosso vino
wine red
rouge vin
Weinrot
rojo vino



RAL 3005

Him & Her Lucida /
Korzina / Zontik

grafite
graphite
graphite
Graphit
grafito

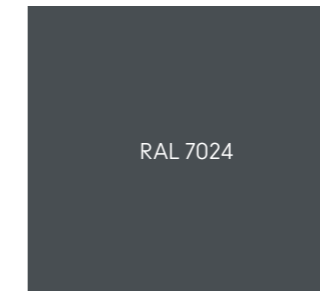

RAL 7024

Him & Her Lucida

oro perlato
pearl gold
or nacré
Perlgold
oro perlado



RAL 1036

Him & Her Lucida

rosso arancio chiaro
bright red orange
orangé rouge clair
Hellrotorange
rojo claro aranjado



RAL 2008

Him & Her Lucida

violetto perlato
pearl violet
violet nacré
Perlviolett
violeta perlado



RAL 4011

Him & Her Lucida

blu oltremare
ultramarine blu
bleu outremer
Ultramarinblau
azul ultramar



RAL 5002

Him & Her Lucida

blu acqua
water blue
bleu d'eau
Wasserblau
azul agua

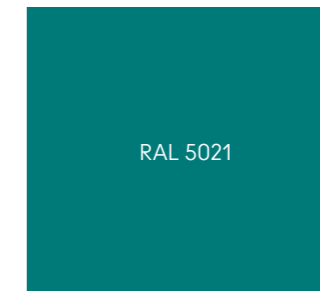

RAL 5021

Him & Her Lucida

blu notte perlato
pearl night blue
bleu nuit nacré
Perlnachtblau
azul noche perlado



RAL 5026

Him & Her Lucida

Fenix, Rattan e Midollino

/ Fenix, Rattan and Natural Wicker

Fenix NTM® nero ingo 0720
RAL Design 000 25 00
Pantone P 179-16 C
Ncs S 8500-N

Fenix NTM® bianco kos 0032
RAL 9016
Pantone P 1-9 C
Ncs S 0500-N

Fenix NTA® Acciaio Hamilton
Fenix NTA® Hamilton Steel
Fenix NTA® Acier Hamilton
Fenix NTA® Hamilton Stahl
Fenix NTA® Acero Hamilton



Bolero / Flower /
Lazy Susan / Tango

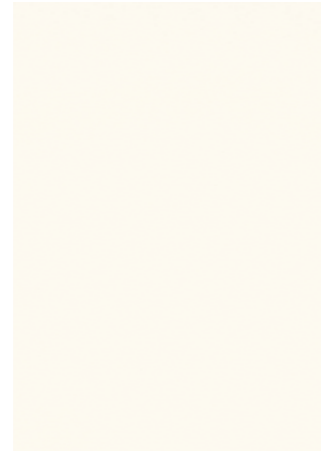

Bolero / Flower / Tango

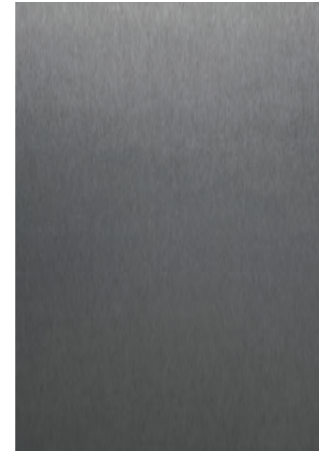

Bolero / Tango

midollino naturale
natural wicker
osier naturel
Peddigrohr natur
mimbre natural



Bar / Charlotte / Sin

rattan
rattan
rotin
Rattan
ratán



Raphia Rattan / Raphia Rocking

Cuoio Pieno Fiore ed Ecopelle

/ Hard Leather Grade 1 and Faux Leather

cuoio pieno fiore naturale
hard leather grade 1 natural
cuir pleine fleur naturel
Kernleder Natur
cuero natural



Pablita / Tout le Jour

cuoio pieno fiore nero
hard leather grade 1 black
cuir pleine fleur noir
Kernleder Schwarz
cuero negro

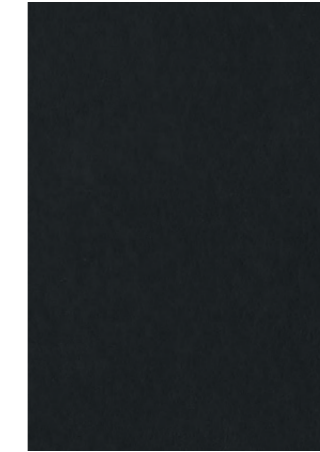

Pablita / Tout le Jour

cuoio pieno fiore grigio talpa
hard leather grade 1 taupe
cuir pleine fleur taupe
Kernleder Taupe
cuero gris raton



Pablita / Tout le Jour

cuoio pieno fiore testa di moro
hard leather grade 1 brown
cuir pleine fleur brun foncé
Kernleder Dunkelbrown
cuero testa di moro



Pablita / Tout le Jour

Ecopelle
Faux Leather
Similcuir
Kunstleder
Ecopiel



Network

Ecopelle
Faux Leather
Similcuir
Kunstleder
Ecopiel

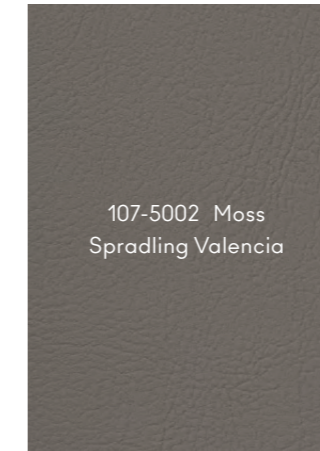

Network

Ecopelle
Faux Leather
Similcuir
Kunstleder
Ecopiel



Network

Ecopelle
Faux Leather
Similcuir
Kunstleder
Ecopiel

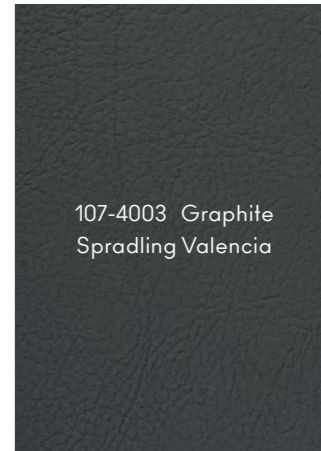

Network

nero
black
noir
Schwarz
negro



Lepel

bianco
white
blanc
Weiß
blanco

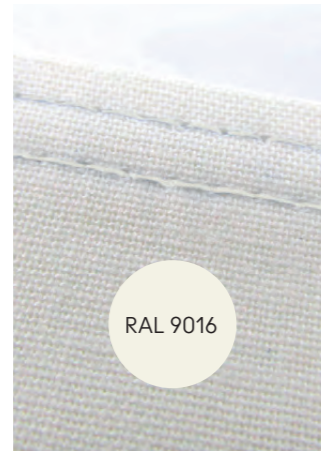

Lepel

polvere
dusty grey
gris poussière
Staubgrau
gris polvo



Lepel

giallo navone
colza yellow
jaune colza
Rapsgelb
amarillo colza



Lepel

rosso arancio chiaro
bright red orange
orangé rouge clair
Hellrotorange
rojo claro anaranjado



Lepel

rosso rubino
ruby red
rouge rubis
Rubinrot
rojo rubí



Lepel

rosa chiaro
light pink
rose clair
Hellrosa
rosa claro



Lepel

marrone noce
nut brown
brun noisette
Nussbraun
pardo nuez



Lepel

blu cobalto
cobalt blue
bleu cobalt
Kobaltblau
azul cobalto



Lepel

blu traffico
traffic blue
bleu signalisation
Verkehrsblau
azul tráfico



Lepel

verde brillante
luminous green
vert brillant
Leuchtgrün
verde brillante



Lepel

verde canna
reed green
vert jonc
Schilfgrün
verde caña



Lepel

lana lampone
raspberry red wool
laine rouge framboise
Himbeerrot Wolle
lana rojo frambuesa

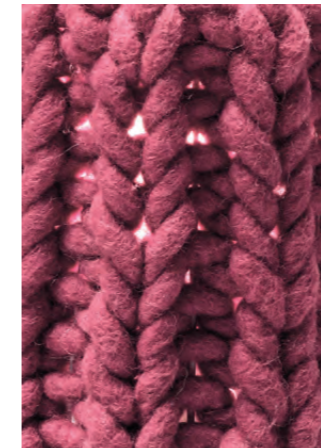

Granny

lana bianco ecrù
pure white wool
laine blanc pur
Reinweiß Wolle
lana blanco puro



Granny

lana grigio chiaro
light grey wool
laine gris clair
Lichtgrau Wolle
lana gris luminoso



Granny

Schede tecniche
Technical sheets
Fiches techniques
Technische Datenblätter
Fichas técnicas

**Outdoor protetto**

Prodotto adatto ad ambienti esterni protetti (es. verande coperte). Non adatto ad ambienti con presenza di pioggia, nebbia, rugiada o umidità persistente. È necessario il ricovero in area chiusa durante la notte. I prodotti realizzati con materiali naturali sono comunque soggetti a deterioramento.

Protected outdoor

Protected product suitable for protected outdoor areas (e.g. covered verandas). Not suitable for environments with rain, fog, dew or persistent humidity. Shelter in a closed area is necessary overnight. Products made from natural materials are however subject to deterioration.

Outdoor protégé

Produit adapté aux extérieurs protégés (par ex. vérandas couvertes). Ne convient pas aux environnements avec pluie, brouillard, rosée ou humidité persistante. Il est nécessaire de le rentrer dans une zone fermée pendant la nuit. Les produits fabriqués à partir de matériaux naturels peuvent, quoi qu'il en soit, se détériorer.

Geschützte Außenbereiche

Produkt, geeignet für geschützte Außenbereiche. Nicht geeignet für Umgebungen, die anhaltendem Regen, Nebel, Tau oder Feuchtigkeit ausgesetzt sind. Für die Nacht muss das Produkt in einen geschlossenen Bereich verlegt werden. Natürlichen Materialien unterliegen der Gefahr beschädigt zu werden.

Outdoor protegido

Producto apto para espacios externos protegidos (p. ej., verandas cubiertas). No apto para entornos con lluvia, niebla, rocío o humedad persistentes. Debe conservarse en lugar cerrado durante la noche. En todo caso, los productos realizados con materiales naturales están sujetos a deterioro.

**Pioggia**

Prodotto adatto ad ambienti esterni con precipitazioni atmosferiche normali. In caso di pioggia persistente è necessario il ricovero in area protetta. I prodotti realizzati con materiali naturali sono comunque soggetti a deterioramento.

Rain

Product suitable for outdoor environments with normal atmospheric precipitation. In case of persistent rain, shelter in a protected area is necessary. Products made from natural materials are however subject to deterioration.

Pluie

Produit adapté aux environnements extérieurs avec précipitations atmosphériques normales. En cas de pluie persistante, il est nécessaire de le rentrer dans une zone protégée. Les matériaux naturels peuvent, quoi qu'il en soit, se détériorer.

Regen

Das Produkt ist für Außenbereiche mit normalem Niederschlag geeignet. Bei anhaltendem Regen ist es notwendig, das Produkt in einen geschützten Bereich zu verlegen. Natürlichen Materialien unterliegen der Gefahr beschädigt zu werden.

Lluvia

Producto apto para espacios externos con precipitaciones normales. En caso de lluvia persistente se debe conservar en un área protegida. En todo caso, los productos realizados con materiales naturales están sujetos a deterioro.

**Salsedine**

Prodotto adatto ad aree marittime o con presenza di nebbia salina. Lavare frequentemente.

Seaside

Product suitable for sea areas or with salt spray. Wash frequently.

Bord de mer

Produit adapté aux zones maritimes ou en présence de brouillard salin. Laver fréquemment.

Am Meer

Für die Verwendung in Meernähe oder in Salznebel ausgesetzten Bereiche geeignet. Häufig waschen.

Orilla del mar

Producto apto para áreas marítimas con presencia de nieblas salinas. Lavar con frecuencia.

**Impilabile**

Prodotto realizzato per poter essere impilato.

Stackable

Product designed to be stacked.

Empilable

Produit conçu pour être empilé.

Stapelbar

Das Produkt ist zum Stapeln geeignet.

Apilable

Producto diseñado para ser apilado.

Struttura

› polietilene
bianco
beige

Structure

› polyethylene
white
beige grey

Structure

› polyéthylène
blanc
gris beige

Struktur

› Polyethylen
Weiß
Beigegrau

Estructura

› polietileno
blanco
gris beige

Pomelli

› rovere naturale

Knobs

› natural oak

Poignées

› chêne naturel

Kleiderhaken

› Eiche Natur

Pomos

› roble natural

Base

› metallo in tinta
con la struttura

Base

› metal in matching
colour with the structure

Base

› metal en teint
avec la structure

Basis

› Metall Ton-in-Ton
Farbe wie die Struktur

Base

› metal del mismo color
que la estructura

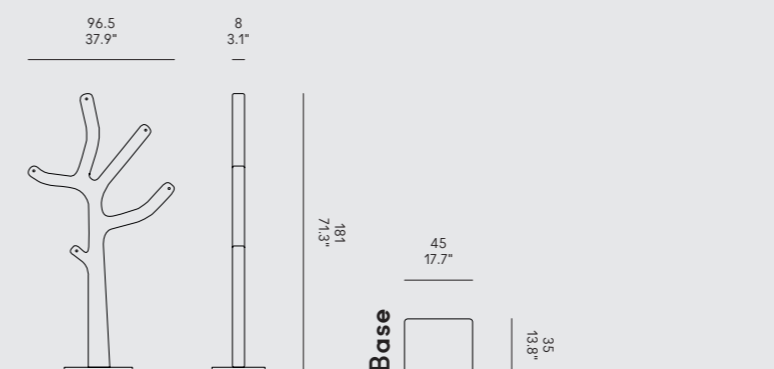

Alberto Stendibiancheria

CASAMANIA / Fabrica, 2005

Struttura

› polietilene
bianco
beige

Structure

› polyethylene
white
beige grey

Structure

› polyéthylène
blanc
gris beige

Struktur

› Polyethylen
Weiß
Beigegrau

Estructura

› polietileno
blanco
gris beige

Base

› acciaio

Base

› steel

Base

› acier

Basis

› Stahl

Base

› acero

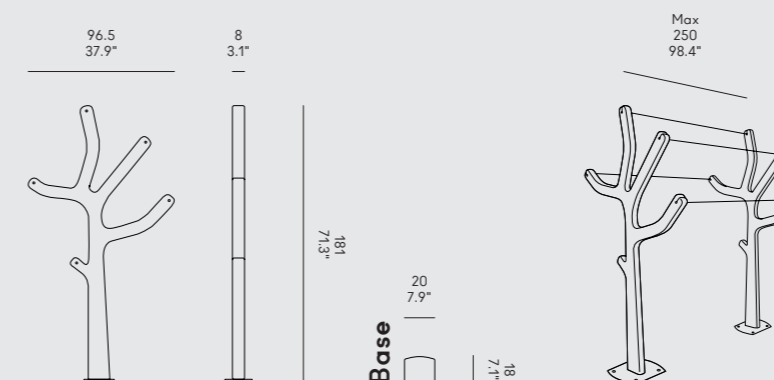

Finitura

> metallo
nero
bianco

Finish

> metal
black
white

Finition

> métal
noir
blanc

Ausführung

> Metall
Schwarz
Weiß

Acabado

> metal
negro
blanco

Optional

> cuscino indoor
> cuscino outdoor

Optional

> indoor cushion
> outdoor cushion

Optionnel

> coussin indoor
> coussin outdoor

Optional

> Indoor-Kissen
> Outdoor-Kissen

Opcional

> cojín indoor
> cojín outdoor

Scocca e ripiani

> metallo nero

Body and shelver

> black metal

Corps et étagères

> métal noir

Korpus und Böden

> schwarzes Metall

Cuerpo y estantes

> metal negro

Cornice

> alluminio anodizzato

Frame

> anodized aluminium

Cadre

> aluminium anodisé

Rahmen

> eloxiertes Aluminium

Marco

> aluminio anodizado

Nota

Montaggio a parete.
Specchio con pellicola anti-infortunistica. Lo specchio è fisso. Un contenitore alle spalle dello specchio scorre esternamente a destra e a sinistra.

Notice

Wall mounting. Mirror with safety film. Mirror is fixed. A container behind the mirror slides externally to the right and left.

Avertissement

Montage mural. Miroir avec film de sécurité. Le miroir est fixe. Un conteneur derrière le miroir glisse vers l'extérieur à droite et à gauche.

Anmerkungen

Wandmontage. Spiegel mit Sicherheitsfolie. Der Spiegel ist fixiert. Ein Behälter hinter dem Spiegel gleitet außen nach rechts und links.

Aviso

Montaje a la pared. Espejo con película de seguridad. El espejo queda fijo. Un contenedor detrás del espejo se desliza externamente a la derecha y a la izquierda.

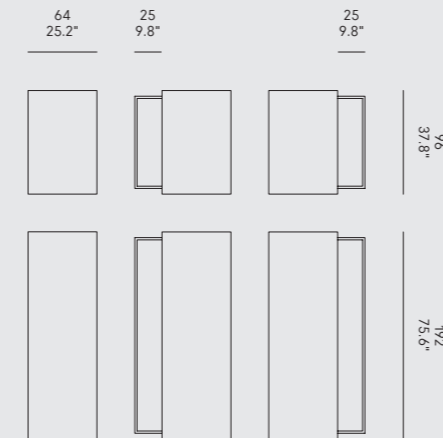
Profondità

> 17 cm

Depth

> 17 cm / 6.7"

Profondeur

> 17 cm

Tiefe

> 17 cm

Profundidad

> 17 cm

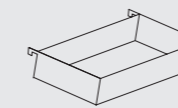

Ripiani dritti
portaoggetti

Straight storage
shelves

Étagères de rangement
droites

Einlegeböden für die
Lagerung

Repisas horizontales
porta objetos

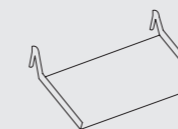

Ripiani inclinati
per uso scarpiera

Inclined shelves for
shoe rack use

Tablettes inclinées pour
étagères à chaussures

Schrägbödenregale
für Schuhe

Repisas inclinadas para
zapatos

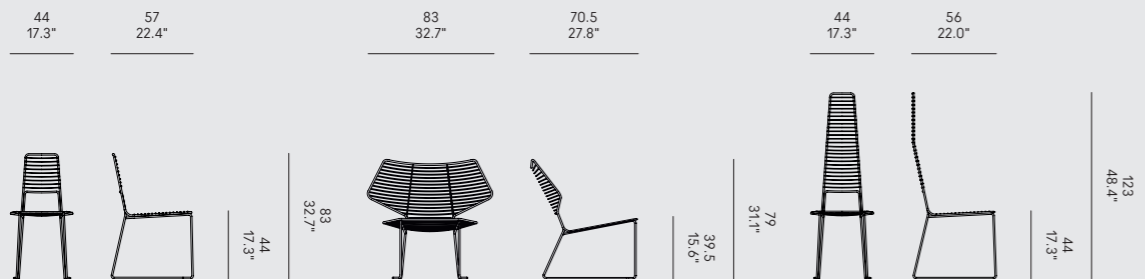

Struttura

> metallo
nero
bianco

Structure

> metal
black
white

Structure

> métal
noir
blanc

Struktur

> Metall
Schwarz
Weiß

Estructura

> metal
negro
blanco

Seduta e schienale

> polipropilene
nero
bianco

Seat and backrest

> polypropylene
black
white

Assise et dossier

> polypropylène
noir
blanc

Sitz und Rückenlehne

> Polypropylen
Schwarz
Weiß

Asiento y respaldo

> polipropileno
negro
blanco

Finitura

> rovere naturale
> rovere moca
> noce canaletto

Finish

> natural oak
> mocha oak
> walnut

Finition

> chêne naturel
> chêne moka
> noyer

Ausführung

> Eiche Natur
> Eiche Mokka
> Nussbaum

Acabado

> roble natural
> roble moca
> nogal

Nota

Impianto elettrico e luce LED sotto la base.

Notice

Electrical system and LED light under the base.

Avertissement

Système électrique et éclairage LED sous la base.

Anmerkungen

Elektrisches System und LED-Licht unter dem Basisfuß.

Aviso

Sistema eléctrico y luz LED debajo de la base.

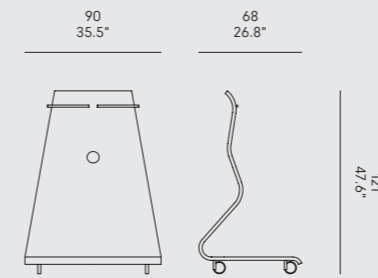

Elfo Outdoor

Imbottitura drenante

Draining padding

Rembourrage drainant

Drainagepolsterung

Relleno drenante

Rivestimento

> tessuto outdoor

Cover

> outdoor fabric

Revêtement

> tissu outdoor

Bezug

> Outdoor-Stoff

Funda

> tejido outdoor

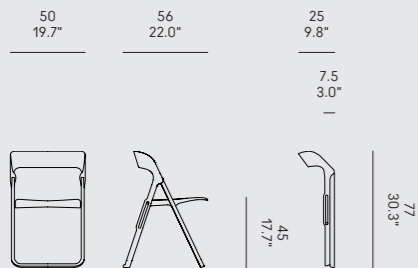
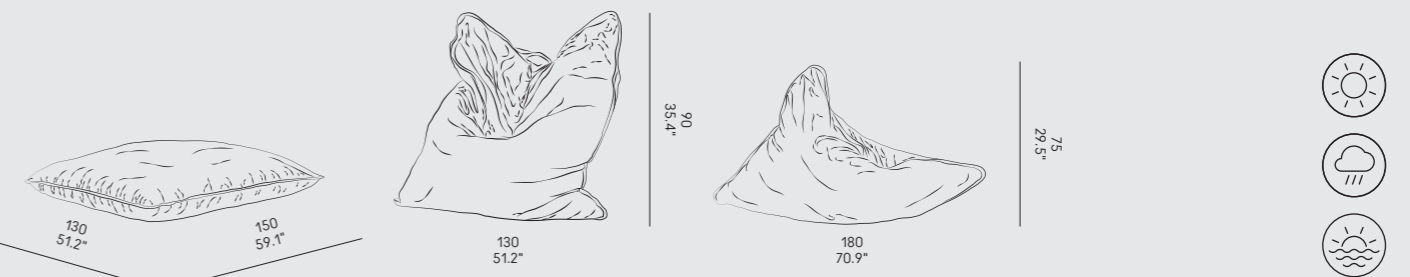

Cornice

› alluminio

NotaSpecchio con pellicola
anti-infortunisticaFrame

› aluminium

Notice

Mirror with safety film

Cadre

› aluminium

AvertissementMiroir avec film
de sécuritéRahmen

› Aluminium

AnmerkungenSpiegel mit
SicherheitsfolieMarco

› aluminio

AvisoEspejo con película
de seguridadParalume

› lana

› rosso lampone (A)
› bianco puro (B)
› grigio luce (C)Cavo elettrico› nero (A)
› rosso (B)
› grigio (C)Lampshade

› wool

› raspberry red (A)
› pure white (B)
› light grey (C)Electric cable› black (A)
› red (B)
› grey (C)Abat-jour

› laine

› rouge framboise (A)
› blanc pur (B)
› gris clair (C)Câble électrique› noir (A)
› rouge (B)
› gris (C)Lampenschirm

› Wolle

› Himbeerrot (A)
› Reinweiß (B)
› Lichtgrau (C)Elektrisches Kabel› Schwarz (A)
› Rot (B)
› Grau (C)Pantalla

› lana

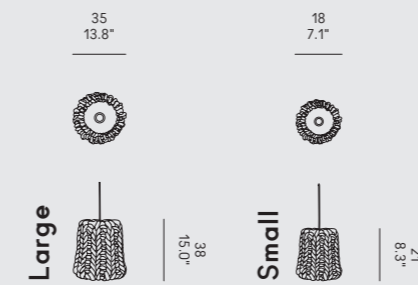
› rojo frambuesa (A)
› blanco puro (B)
› gris luminoso (C)Cable eléctrico› negro (A)
› rojo (B)
› gris (C)

Hcb

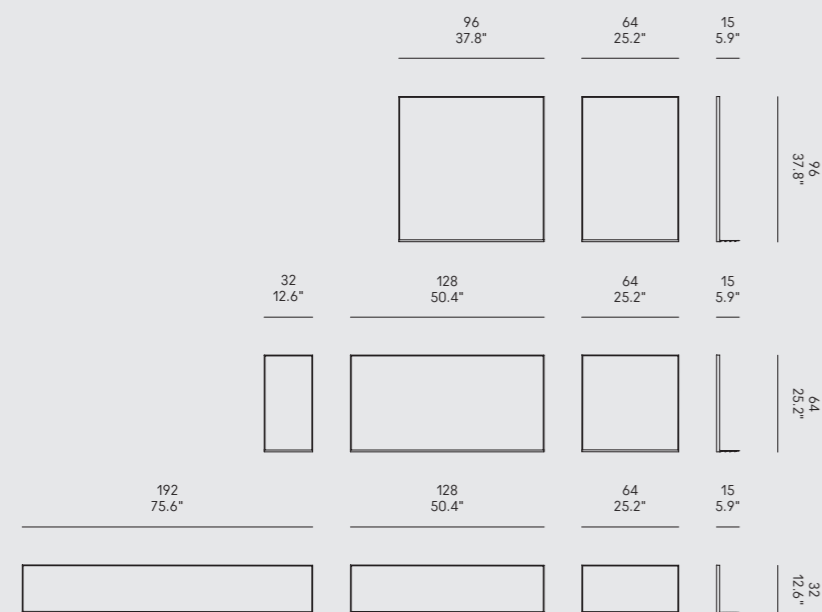
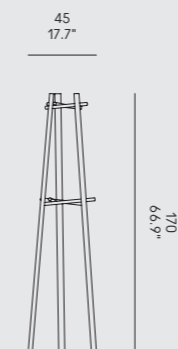
Finitura› faggio massello
› bois blond
› imbiancato
› mocaFinish› solid beech
› bois blond
› whitened
› mochaFinition› hêtre massif
› bois blond
› blanchi
› mokaAusführung› Massiv Buche
› Bois Blond
› Geweißt
› MokkaAcabado› haya maciza
› bois blond
› blanqueada
› moca

| | | | | |
|--|---|--|---|---|
| <u>Finitura</u> > pietra leccese | <u>Finish</u> > Lecce limestone | <u>Finition</u> > pierre de Lecce | <u>Ausführung</u> > Lecce-Stein | <u>Acabado</u> > piedra de Lecce |
| > okumé naturale > okumé laccato opaco bianco | > natural okoume > white matt lacquered okoume | > okumé naturel > okumé laqué mat blanc | > Okume Natur > weiß matt lackiert Okume | > ocume natural > ocume lacado mate blanco |

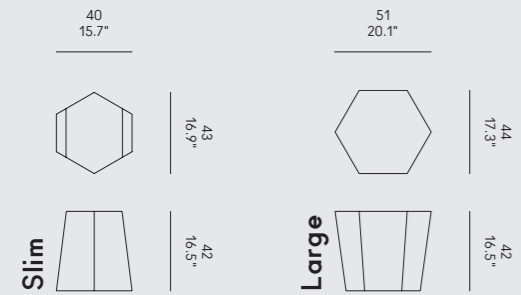

| | | | | |
|---|--|--|---|---|
| <u>Struttura</u> > metallo cromato | <u>Structure</u> > chromed metal | <u>Structure</u> > métal chrome | <u>Struktur</u> > verchromtes Metall | <u>Estructura</u> > metal cromado |
| <u>Pomelli</u> > poliammide nero bianco | <u>Knobs</u> > polyamide black white | <u>Poignées</u> > polyamide noir blanc | <u>Kleiderhaken</u> > Polyamid Schwarz Weiß | <u>Pomos</u> > poliamida negro blanco |

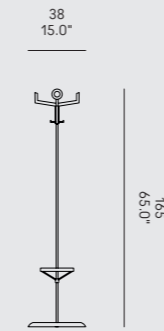

Him & Her *Opaca*

| | | | | |
|---|---|---|---|---|
| <u>Finitura</u> > polietilene opaco tinto in massa nero bianco polvere beige | <u>Finish</u> > dyed-through matt polyethylene black white dusty grey beige grey | <u>Finition</u> > polyéthylène mat teinté en mass noir blanc gris poussière gris beige | <u>Ausführung</u> > matt durchgefärbtes Polyethylen Schwarz Weiß Staubgrau Beigegräu | <u>Acabado</u> > polietileno opaco teñido en masa negro blanco gris gris beige |
|---|---|---|---|---|

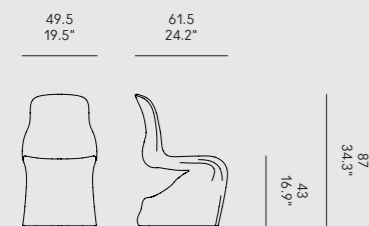

Kant

| | | | | |
|---|--|--|---|---|
| <u>Finitura</u> > polipropilene opaco tinto in massa nero bianco | <u>Finish</u> > dyed-through matt polypropylene black white | <u>Finition</u> > polypropylène mat teinté en mass noir blanc | <u>Ausführung</u> > matt durchgefärbtes Polyethylen Schwarz Weiß | <u>Acabado</u> > polipropileno opaco teñido en masa negro blanco |
|---|--|--|---|---|



Finitura esterna

- › polietilene lucido nero
- › polvere beige
- › rosso vino
- › polietilene opaco bianco (A)

External Finish

- › glossy polyethylene black
- › dusty grey
- › beige grey
- › wine red
- › white matt polyethylene (A)

Finition extérieure

- › polyéthylène brillant noir
- › gris poussière
- › gris beige
- › rouge vin
- › polyéthylène mat blanc (A)

Außen Ausführung

- › glänzend Polyethylen Schwarz
- › Staubgrau
- › Beigegrau
- › Weinrot
- › weiß matt Polyethylen (A)

Acabado exterior

- › polietileno brillante negro
- › gris polvo
- › gris beige
- › rojo vino
- › polietileno mate blanco (A)

Finitura interna

- › polietilene opaco bianco

Finitura interna

- › white matt polyethylene

Finition intérieure

- › polyéthylène mat blanc

Innen Ausführung

- › weiß matt Polyethylen

Acabado interior

- › polietileno mate blanco

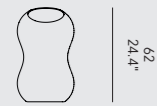
37.5
14.8"

A

Finitura

- › polietilene bianco
- › bordeaux
- › verde chiaro
- › verde scuro

Finish

- › polyethylene white
- › bordeaux
- › light green
- › dark green

Finition

- › polyéthylène blanc
- › bordeaux
- › vert clair
- › vert foncé

Ausführung

- › Polyethylen Weiß
- › Bordeaux
- › Lichtgrün
- › Dunkelgrün

Acabado

- › polietileno blanco
- › bordeaux
- › verde claro
- › verde oscuro

Optional

- › filo in acciaio 2 metri e kit di fissaggio al muro per la messa in tensione del cavo.

Optional

- › 2 meter steel wire and wall mounting kit for tensioning the wire.

Optionnel

- › 2 mètres de fil d'acier et kit de montage mural pour la mise en tension du fil.

Optional

- › 2 Meter Stahldraht und spannende Wandmontage-Set.

Opcional

- › cable de acero de 2 metros y kit de montaje en pared para tensar el cable.

17.5
6.9"

Mamanonmama

Cornice

- › salice nero massello

Frame

- › solid black willow

Cadre

- › saule noir massif

Rahmen

- › Massiv schwarze Weide

Marco

- › sauce negro macizo

Nota

Specchio con pellicola anti-infortunistica.

Notice

Mirror with safety film.

Avertissement

Miroir avec film de sécurité.

Anmerkungen

Spiegel mit Sicherheitsfolie.

Aviso

Espejo con película de seguridad.

18 6
7.0" 2.3"22 8
8.7" 3.2"24 8
9.5" 3.2"32 10
12.6" 3.9"40 12
15.8" 4.7"

Meduse Tavolino

Finitura

- › metallo nero
- › bianco
- › rosso vino
- › bruno

Finish

- › metal black
- › white
- › wine red
- › browngrey

Finition

- › métal noir
- › blanc
- › rouge vin
- › gris brun

Ausführung

- › Metall Schwarz
- › Weiß
- › Weinrot
- › Braungrau

Acabado

- › metal negro
- › blanco
- › rojo vino
- › gris parduzco

30
11.8"20
7.9"50
19.7"35
13.8"4.4
1.73"37.5
14.8"

Imbottitura drenanteDraining paddingRembourrage drainantDrainagepolsterungRelleno drenanteRivestimento

› tessuto outdoor

Cover

› outdoor fabric

Revêtement

› tissu outdoor

Bezug

› Outdoor-Stoff

Funda

› tejido outdoor

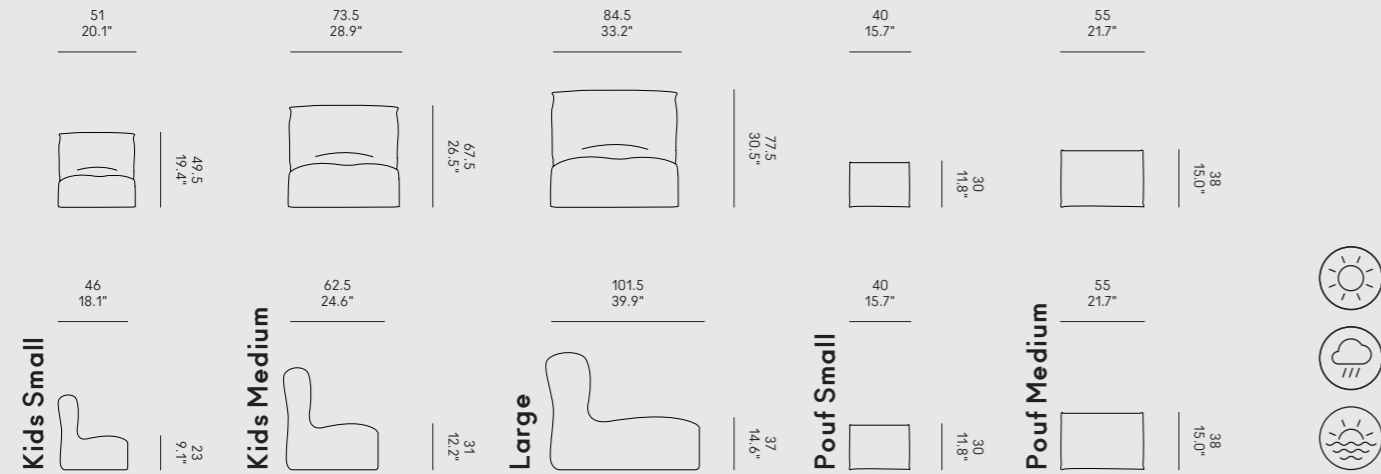
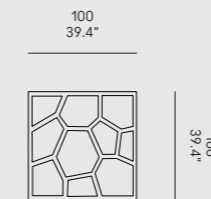
Finitura› polipropilene
espanso
nero
bianco
polvere
beigeFinish› expanded
polypropylene
black
white
dusty grey
beige greyFinition› polypropylène
expansé
noir
blanc
gris poussière
gris beigeAusführung› expandiertes
Polypropylen
Schwarz
Weiß
Staubgrau
BeigegräuEstructura› polipropileno
expandido
negro
blanco
gris polvo
gris beigeProfondità

› 35 cm

Depth

› 35 cm / 13.8"

Profondeur

› 35 cm

Tiefe

› 35 cm

Profundidad

› 35 cm

Struttura› noce canaletto
e acciaio satinatoStructure› walnut and
brushed steelStructure› noyer et
acier satinéStruktur› Nussbaum und
satinierter StahlEstructura› nogal y
acero satinadoParalume

› tessuto

Lampshade

› fabric

Abat-jour

› tissu

Lampenschirm

› Stoff

Pantalla

› tela

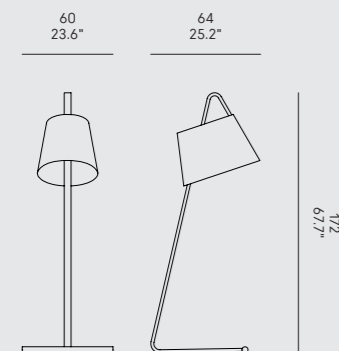
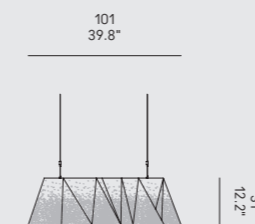
Finitura› legno origami
in noce canaletto
brevetto HORMFinish› origami wood
in walnut
HORM patentFinition› bois origami
en noyer
brevet HORMAusführung› Origami-Nussbaum
HORM-PatentAcabado› madera origami
de nogal
patente HORMProfondità

› 40 cm

Depth

› 40 cm / 15.7"

Profondeur

› 40 cm

Tiefe

› 40 cm

Profundidad

› 40 cm

Imbottitura drenanteDraining paddingRembourrage drainantDrainagepolsterungRelleno drenanteRivestimento

› tessuto outdoor

Cover

› outdoor fabric

Revêtement

› tissu outdoor

Bezug

› Outdoor-Stoff

Funda

› tejido outdoor

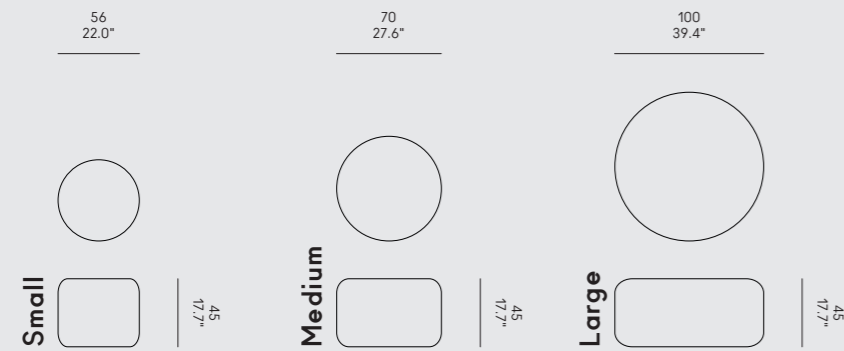

QuaDror™ Sculpture

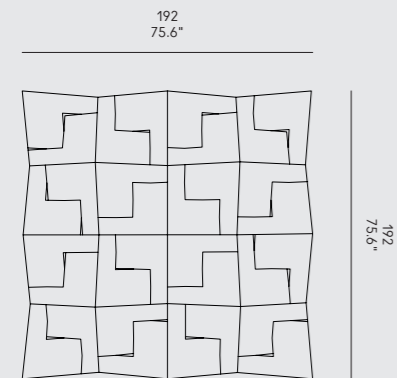
Finitura› metallo crudo
e copriviti in ebanoFinish› crude metal and
ebony screw coversFinition› métal cru et couvre
vis en ébèneAusführung› Rohmetall und
Schraubenabdeckungen
aus EbenholzAcabado› metal crudo y cubre
tornillos en ébanoProfondità

› 27 cm

Depth

› 27 cm / 10.6"

Profondeur

› 27 cm

Tiefe

› 27 cm

Profundidad

› 27 cm

Raphia Alluminio

Finitura› alluminio
bianco
grafiteFinish› aluminium
white
graphiteFinition› aluminium
blanc
graphiteAusführung› Aluminium
Weiß
GraphitAcabado› aluminio
blanco
grafitoOptional

› cuscino outdoor

Optional

› outdoor cushion

Optionnel

› coussin outdoor

Optional

› Outdoor-Kissen

Opcional

› cojín outdoor

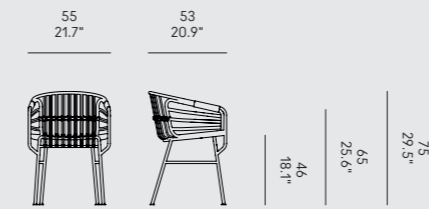

Raphia Rattan

Struttura› metallo
nero
bianco
polvere
beigeStructure› metal
black
white
dusty grey
beige greyStructure› métal
noir
blanc
gris poussière
gris beigeStruktur› Metall
Schwarz
Weiß
Staubgrau
BeigegräuEstructura› metal
negro
blanco
gris polvo
gris beigeSeduta e schienale› rattan con legacci in
nylonSeat and backrest

› rattan with nylon ties

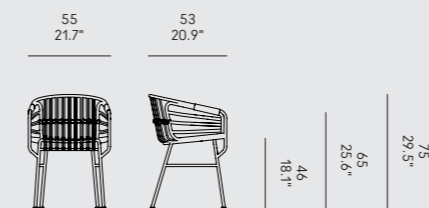
Assise et dossier› rotin avec fermeture
en nylonSitz und Rückenlehne› Rattan mit Nylonbinde
de nylonAsiento y respaldo› ratán con ligaduras
de nylonOptional› cuscino indoor
› cuscino outdoorOptional› indoor cushion
› outdoor cushionOptionnel› coussin indoor
› coussin outdoorOptional› Indoor-Kissen
› Outdoor-KissenOpcional› cojín indoor
› cojín outdoor

Riddled Buffet

HORM / Steven Holl, 2006

Finitura

› alluminio verniciato
e legno origami
in ebano
brevetto HORM

Finish

› varnished aluminium
and origami
wood in ebony
HORM patent

Finition

› aluminium verni
et bois origami
en ébène
brevet HORM

Ausführung

› beschichtetes Aluminium
und Origami-Ebenholz
HORM-Patent

Acabado

› aluminio barnizado
y madera origami
de ébano
patente HORM

Nota

I contenitori in legno
sono apribili

Notice

The origami wood
containers can be open

Avertissement

Possibilité d'ouvrir les
conteneurs en bois

Anmerkungen

Holzbehälter können
geöffnet werden

Aviso

Los contenedores de
madera se pueden abrir

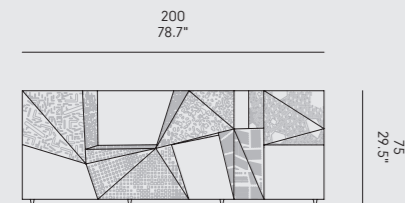
Profondità

› 50 cm

Depth

› 50 cm / 19.7"

Profondeur

› 50 cm

Tiefe

› 50 cm

Profundidad

› 50 cm

Ripples Outdoor

HORM / SHH – homage to Toyo Ito, 2011

Finitura

› multistrato di okumè

Finish

› okoume plywood

Finition

› multicouches en okumè

Ausführung

› Multiplex aus Okume

Acabado

› multicapa en okumè

Nota

Sulla seduta sono
presenti dei fori per il
drenaggio dell'acqua

Notice

› On the seats there are
holes for the drainage
of water

Avertissement

Les trous dans le siège
permettent à l'eau de
s'écouler

Anmerkungen

Auf den Sitzen befinden
sich Löcher für die
Wasserableitung

Aviso

En los asientos hay
agujeros para el
drenaje del agua

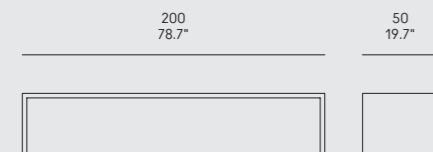

Riddled Totem

HORM / Steven Holl, 2006

Finitura

› alluminio verniciato
e legno origami
in noce canaletto
brevetto HORM

Finish

› varnished aluminium
and origami wood
in walnut
HORM patent

Finition

› aluminium verni
et bois origami
en noyer
brevet HORM

Ausführung

› beschichtetes
Aluminium und
Origami-Nussbaum
HORM-Patent

Acabado

› aluminio barnizado
y madera origami
de nogal
patente HORM

Nota

I contenitori in legno
sono apribili

Notice

The origami wood
containers can be open

Avertissement

Possibilité d'ouvrir les
conteneurs en bois

Anmerkungen

Holzbehälter können
geöffnet werden

Aviso

Los contenedores de
madera se pueden abrir

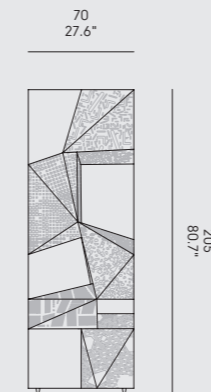
Profondità

› 50 cm

Depth

› 50 cm / 19.7"

Profondeur

› 50 cm

Tiefe

› 50 cm

Profundidad

› 50 cm

Robox
Metallo bianco
> corpo bianco
> cuore rosso

Robox
Metallo grigio
> corpo grigio
> cuore rosso

Robox
Metallo multicolor
> corpo bianco,
blu e giallo
> cuore rosso

Robox
White metal
> white body
> red heart

Robox
Grey metal
> grey body
> red heart

Robox
Multicolor metal
> white blue
and yellow body
> red heart

Robox
Métal blanc
> corps blanc
> cœur rouge

Robox
Métal gris
> corps gris
> cœur rouge

Robox
Métal multicolor
> corps blanc,
bleu et jaune
> cœur rouge

Robox
weißes Metall
> weißer Körper
> rotes Herz

Robox
graues Metall
> grauer Körper
> rotes Herz

Robox
Multicolor Metall
> weißer, blauer
und gelber Körper
> rotes Herz

Robox
Metall blanco
> cuerpo blanco
> corazón rojo

Robox
Metall gris
> cuerpo gris
> corazón rojo

Robox
Metall multicolor
> cuerpo blanco,
azul y amarillo
> corazón rojo

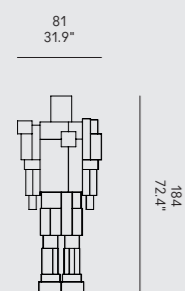

Profondità
> 30 cm

Depth
> 30 cm / 11.8"

Profondeur
> 30 cm

Tiefe
> 30 cm

Profundidad
> 30 cm

Struttura
> metallo cromato

Seduta e schienale
> midollino naturale

Structure
> chromed metal

Seat and backrest
> natural wicker

Structure
> métal chromé

Assise et dossier
> osier naturel

Struktur
> verchromtes Metall

Sitz und Rückenlehne
> Peddigrohr Natur

Estructura
> metal cromado

Asiento y respaldo
> mimbre natural

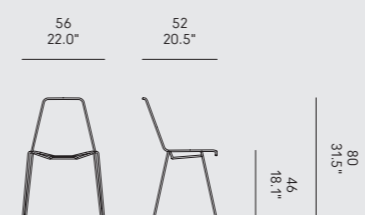

| | | | | |
|--|--|--|--|---|
| Impilabile | Stackable | Empilable | Stapelbar | Apilable |
| Gambe › metallo nero (A) bianco (A) polvere (A) beige (A) cromato (B) | Legs › metal black (A) white (A) dusty grey (A) beige grey (A) chrome (B) | Pieds › métal noir (A) blanc (A) gris poussière (A) gris beige (A) chromé (B) | Beine › Metall Schwarz (A) Weiß (A) Staubgrau (A) Beigegrau (A) Chrom (B) | Patas › metal negro (A) blanco (A) gris polvo (A) gris beige (A) cromado (B) |
| Seduta e schienale › polipropilene nero bianco polvere beige | Seat and backrest › polypropylene black white dusty grey beige grey | Assise et dossier › polypropylène noir blanc gris poussière gris beige | Sitz und Rückenlehne › Polypropylen Schwarz Weiß Staubgrau Beigegrau | Asiento y respaldo › polipropileno negro blanco gris polvo gris beige |

| | | | | |
|--|---|--|--|---|
| Gambe › metallo nero bianco polvere beige | Legs › metal black white dusty grey beige grey | Pieds › métal noir blanc gris poussière gris beige | Beine › Metall Schwarz Weiß Staubgrau Beigegrau | Patas › metal negro blanco gris polvo gris beige |
| Seduta e schienale › polipropilene nero bianco polvere beige | Seat and backrest › polypropylene black white dusty grey beige grey | Assise et dossier › polypropylène noir blanc gris poussière gris beige | Sitz und Rückenlehne › Polypropylen Schwarz Weiß Staubgrau Beigegrau | Asiento y respaldo › polipropileno negro blanco gris polvo gris beige |

48
18.9"

53.5
21.0"



T1 Outdoor

| | | | | |
|--|--|--|---|---|
| Struttura › acciaio 316 (A) › acciaio 304 (B) | Structure › steel 316 (A) › steel 304 (B) | Structure › acier 316 (A) › acier 304 (B) | Struktur › Stahl 316 (A) › Stahl 304 (B) | Estructura › acero 316 (A) › acero 304 (B) |
| Piano › Werzalit bianco | Top › white Werzalit | Plateau › Werzalit blanc | Tischplatte › Weiß Werzalit | Tapa › Werzalit blanco |

70
27.6"

70
27.6"

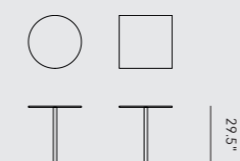

A

B



57.5
22.6"

58
22.8"



A

B



| | | | | |
|--|--|---|---|---|
| <u>Gabbia</u> › metallo nero placcato oro 24K | <u>Cage</u> › metal black 24K gold plated | <u>Cage</u> › métal noir plaqué or 24 carats | <u>Käfig</u> › Metall Schwarz 24K goldplattiert | <u>Jaula</u> › metal negro 24K bañado en oro |
| <u>Uccellino</u> › ceramica nera placcata oro 24K | <u>Bird</u> › ceramic black 24K gold plated | <u>Oiseau</u> › céramique noir plaqué or 24 carats | <u>Vogel</u> › Keramik Schwarz 24K goldplattiert | <u>Pajarito</u> › cerámica negro 24K bañado en oro |

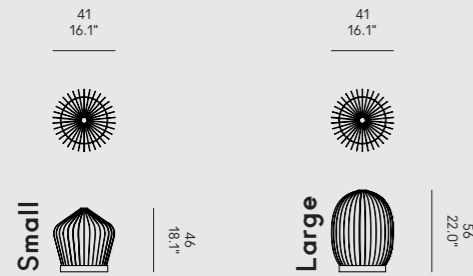

Twist

| | | | | |
|---|--|---|--|--|
| <u>Finitura</u> › faggio massello imbiancato naturale moca bois blond beige tricolor multicolor | <u>Finish</u> › solid beech whitened natural mocha bois blond beige grey tricolor multicolor | <u>Finition</u> › hêtre massif blanchi naturel moka bois blond gris beige tricolor multicolor | <u>Ausführung</u> › Massiv Buche Geweißt Natur Mokka Bois Blond Beigegrü Tricolor Multicolor | <u>Acabado</u> › haya maciza blanqueada natural moca bois blond gris beige tricolor multicolor |
|---|--|---|--|--|

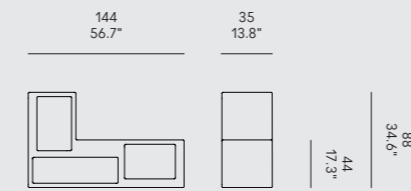
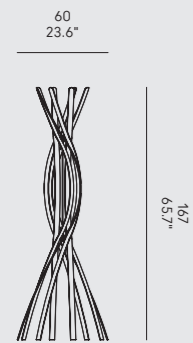

Cornice
> alluminio

Frame
> aluminium

Cadre
> aluminium

Rahmen
> Aluminium

Marco
> aluminio

Nota
Specchio con pellicola
anti-infortunistica.

Notice
Mirror with safety film.

Avertissement
Miroir avec film
de sécurité.

Anmerkungen
Spiegel mit
Sicherheitsfolie.

Aviso
Espejo con película
de seguridad.

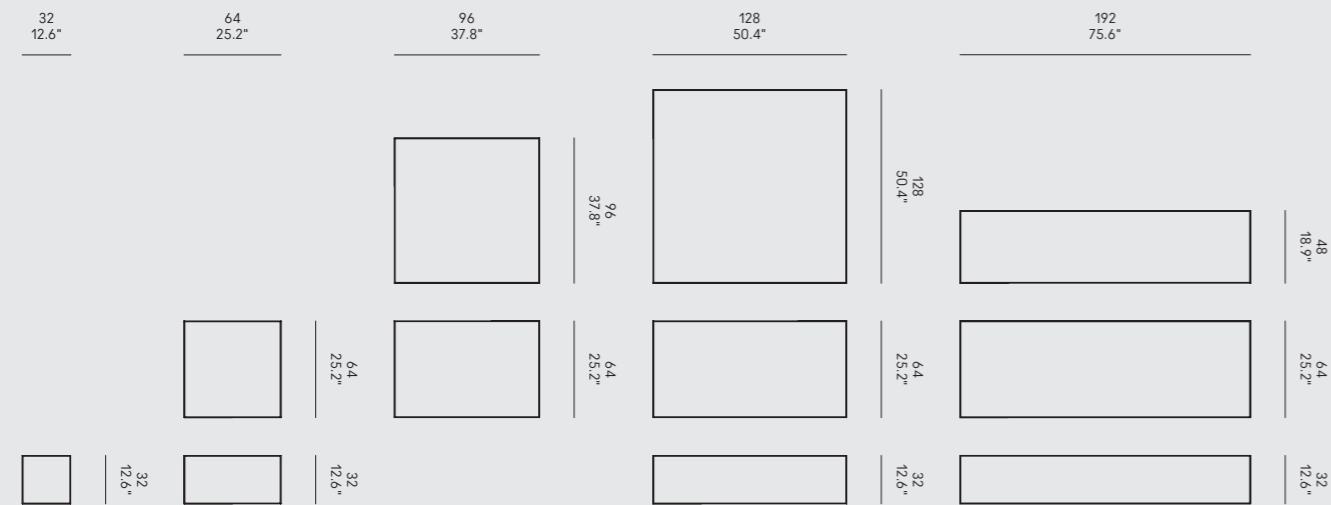

Profondità
> 2 cm

Depth
> 2 cm / 0.8"

Profondeur
> 2 cm

Tiefe
> 2 cm

Profundidad
> 2 cm

Cornice
> alluminio

Frame
> aluminium

Cadre
> aluminium

Rahmen
> Aluminium

Marco
> aluminio

Nota
Specchio con pellicola
anti-infortunistica.

Notice
Mirror with safety film.

Avertissement
Miroir avec film
de sécurité.

Anmerkungen
Spiegel mit
Sicherheitsfolie.

Aviso
Espejo con película
de seguridad.

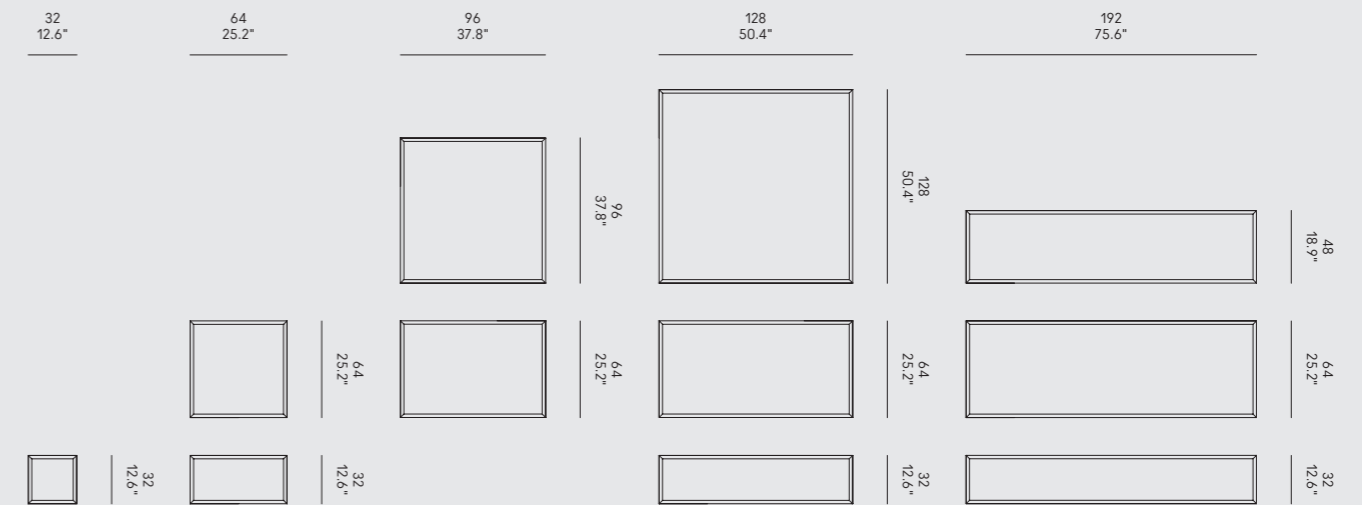

Profondità
> 2 cm

Depth
> 2 cm / 0.8"

Profondeur
> 2 cm

Tiefe
> 2 cm

Profundidad
> 2 cm

Impilabile

Gambe

› metallo
 nero (A)
 bianco (A)
 polvere (A)
 beige (A)
 cromato (B)

Stackable

Legs

› metal
 black (A)
 white (A)
 dusty grey (A)
 beige grey (A)
 chrome (B)

Empilable

Pieds

› métal
 noir (A)
 blanc (A)
 gris poussière (A)
 gris beige (A)
 chromé (B)

Stapelbar

Beine

› Metall
 Schwarz (A)
 Weiß (A)
 Staubgrau (A)
 Beigegräu (A)
 Chrom (B)

Apilable

Patas

› metal
 negro (A)
 blanco (A)
 gris polvo (A)
 gris beige (A)
 cromado (B)

Seduta e schienale

› polipropilene
 nero
 bianco
 polvere
 beige

Seat and backrest

› polypropylene
 black
 white
 dusty grey
 beige grey

Assise et dossier

› polypropylène
 noir
 blanc
 gris poussière
 gris beige

Sitz und Rückenlehne

› Polypropylen
 Schwarz
 Weiß
 Staubgrau
 Beigegräu

Asiento y respaldo

› polipropileno
 negro
 blanco
 gris polvo
 gris beige

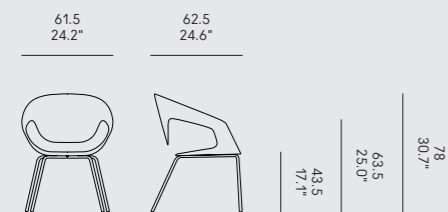
Finitura

› legno massello
 rovere naturale
 noce canaletto

Finish

› solid wood
 natural oak
 walnut

Finition

› bois massif
 chêne naturel
 noyer

Ausführung

› Massivholz
 Eiche Natur
 Nussbaum

Acabado

› madera maciza
 roble natural
 nogal

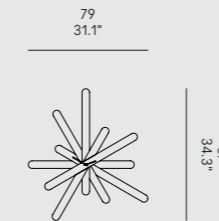
Finitura

› rovere massello
 naturale
 moca
 bianco

Finish

› solid oak
 natural
 mocha
 white

Finition

› chêne massif
 naturel
 moka
 blanc

Ausführung

› Massiv Eiche
 Natur
 Mokka
 Weiß

Acabado

› roble macizo
 natural
 moca
 blanco

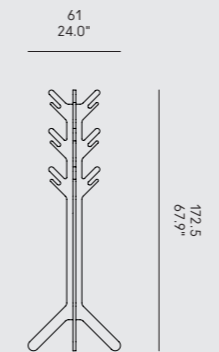
Profondità

› 61 cm

Depth

› 61 cm / 24.0"

Profondeur

› 61 cm

Tiefe

› 61 cm

Profundidad

› 61 cm

Cornice

> alluminio
lucido
nero opaco

Frame

> aluminium
glossy
matt black

Cadre

> aluminium
brillant
noir mat

Rahmen

> Aluminium
glänzend
schwarz matt

Marco

> aluminio
brillante
negro mate

Nota

Specchio con pellicola
anti-infortunistica.

Notice

Mirror with safety film.

Avertissement

Miroir avec film
de sécurité.

Anmerkungen

Spiegel mit
Sicherheitsfolie.

Aviso

Espejo con película
de seguridad.

Finitura esterna

> polietilene lucido
nero
polvere
beige
rosso vino
> polietilene
opaco bianco (A)

External Finish

> glossy polyethylene
black
dusty grey
beige grey
wine red
> white matt
polyethylene (A)

Finition extérieure

> polyéthylène brillant
noir
gris poussière
gris beige
rouge vin
> polyéthylène
mat blanc (A)

Außen Ausführung

> glänzend Polyethylen
Schwarz
Staubgrau
Beigegrü
Weinrot
> weiß matt
Polyethylen (A)

Acabado exterior

> polietileno brillante
negro
gris polvo
gris beige
rojo vino
> polietileno mate
blanco (A)

Finitura interna

> polietilene opaco
bianco

Finitura interna

> white matt
polyethylene

Finition intérieure

> polyéthylène
mat blanc

Innen Ausführung

> weiß matt
Polyethylen

Acabado interior

> polietileno mate
blanco

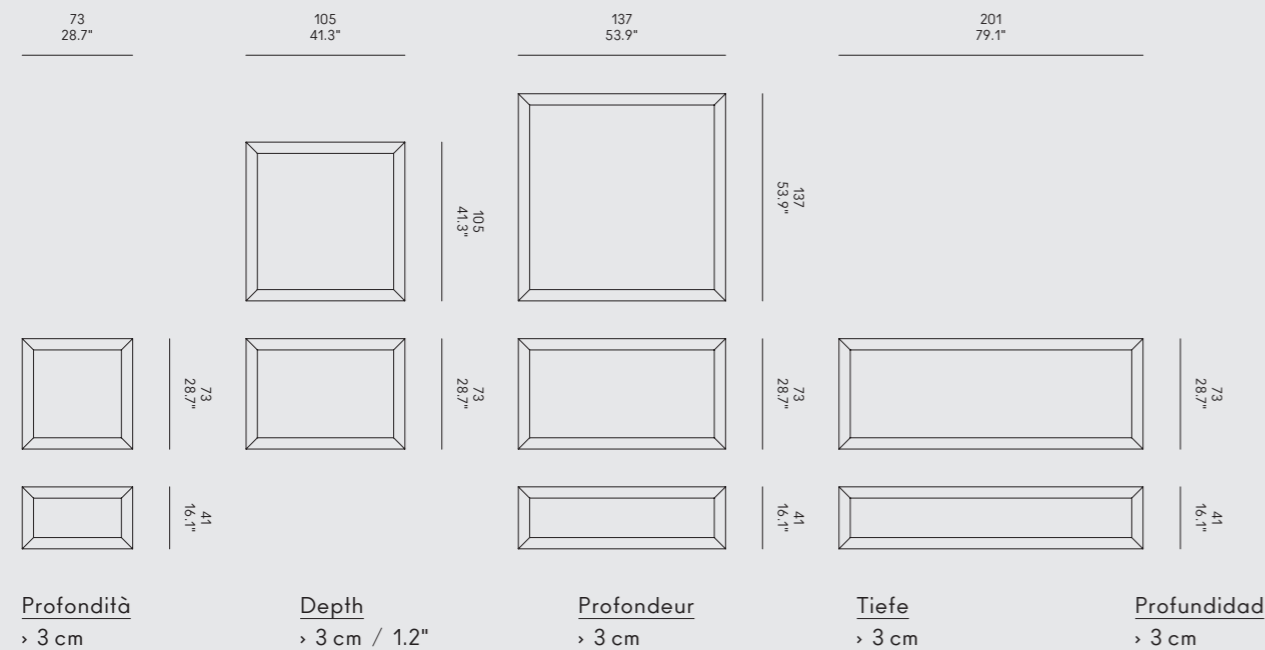

37.5
14.8"



6.2
2.44"

A



Art Director

Renato Zamberlan

Photos

Gianni Antoniali
/ Ikon Productions

Set Dresser

Claudia Sani
/ Ikon Productions

except:

Casamania image bank
18, 19, 46, 47, 48, 49,
50, 52, 53, 66, 67, 72,
73, 74, 97, 101

Thanks to:

Bosa Ceramiche
Cc-tapis
London Art

Horm, Casamania and Orizzonti Italia
are registered trademarks of:

Horm Italia Srl

via Antonio Carpenè, 17
33070 Brugnera (PN)
Italy

International
Sales Desk
orders@horm.it
Tel. +39 0434 1979101

Ufficio Commerciale
Italia
ordini@horm.it
Tel. +39 0434 1979102

horm.it
casamania.it
orizzontiitalia.it

#HormDesign
#Casamania
#HormCasamania

© Horm Italia Srl



Tutti i prodotti illustrati
in questo catalogo sono
Made in Italy

All products illustrated
in this catalogue are
Made in Italy

Tous les produits
illustrés dans
ce catalogue sont
Made in Italy

Alle produkte in
diesem katalog sind
Made in Italy

Todos los productos
presentados en este
catálogo son
Made in Italy

Horm Italia Srl si riserva
la facoltà di apportare,
in qualunque momento
e senza preavviso,
modifiche e/o migliorie
di carattere tecnico
o estetico ai prodotti
illustrati nel presente
catalogo e declina
ogni responsabilità per
eventuali inesattezze
contenute nello stesso.
Le textures ed i colori
dei materiali e delle
finiture hanno valore
indicativo in quanto
soggetti alle tolleranze
dei processi di stampa.

Horm Italia Srl reserves
the right to make, at
any time and without
notice, technical or
aesthetic changes
and/or improvements to
the products illustrated
in this catalogue
and declines all
responsibility for any
inaccuracies contained
in it. Textures and
colours of materials and
finishes are indicative
as they are subject
to the tolerances of
printing processes.

Horm Italia Srl se
réserve le droit
d'apporter, à tout
moment et sans
notification préalable,
des modifications
et/ou des améliorations
de type technique ou
esthétique aux produits
illustrés dans le présent
catalogue, et décline
toute responsabilité
pour les éventuelles
inexactitudes
contenues dans ce
catalogue. Les textures
et les couleurs des
matériaux et des
finitions sont une valeur
indicative parce-que
ils changent selon la
tolérance aux procédés
d'imprimerie.

Horm Italia Srl behält
sich das Recht vor,
jederzeit und ohne
vorherige, Ankündigung
Änderungen
und/oder technische
oder ästhetische
Verbesserungen an
den im vorliegenden
Katalog dargestellten
Produkten vorzunehmen,
und übernimmt keine
Verantwortung
für eventuelle
darin enthaltene
Ungeauigkeiten. Die
Texturen und Farben
der Materialien und
Finish haben einen
indicativen Wert, da sie
von den Toleranzen im
Druckprozess abhängig
sind.

Horm Italia Srl se
reserva la facultad de
aportar, en cualquier
momento y sin previo
aviso, cambios y
mejoras de carácter
técnico o estético a los
productos ilustrados
en este catálogo,
y se exime de toda
responsabilidad
por cualesquiera
inexactitudes que
éste catálogo pueda
contener. Las textures
y los colores de los
materiales y de los
acabados tienen solo
un valor indicativo
porque están sujetos
a la tolerancia de los
procesos de imprenta.

