

VENEZIA

Venezia

Vetro su vetro . trasparenze sui colori.

L'alta artigianalità del vetro soffiato di Murano abbinato a preziosi dettagli in oro ed in argento declinato in un esatto rigore geometrico: questa la serie Venezia.

Anime di vetro colorato racchiuse in solidi di vetro trasparente molato, come fossili del nuovo millennio annegati in cristalli che li proteggono dal tempo.

Ne risulta un oggetto dai bordi vibranti, dal profilo nitido e mobile allo stesso tempo. Un oggetto che fa propria la forma assoluta, nelle sezioni quadre, che omaggiano una meccanica liquida.

Tutto ciò rende la serie Venezia un'icona del lusso, una questione di eleganza discreta ed allusiva.

Venezia

Glass on glass. Transparencies on colours.

The high level of craftsmanship of Murano blown glass, combined with precious details in gold and silver, expressed through an exact geometrical rigour: that is the Venezia series.

Cores of coloured glass enclosed in solids of polished transparent glass, like fossils of the new millennium immersed in crystals to protect them from time.

The result is an object with vibrant edges, with a profile that is distinct and mobile at the same time. An object that makes absolute form its own, in the square sections, in homage to a liquid mechanics.

All this makes the Venezia series an icon of luxury, a matter of discreet and allusive elegance.

Venezia

Verre sur verre. Transparences sur les couleurs.

Le haut artisanat du verre soufflé de Murano associé à de précieux détails en or et en argent décliné avec une grande rigueur géométrique. C'est ainsi que se présente la série Venezia.

Des âmes en verre coloré renfermées dans des solides en verre transparent meulé, comme les fossiles du nouveau millénaire noyés dans des cristaux qui les protègent dans le temps.

Il en découle un objet aux bords vibrants, au profil à la fois

net et mobile. Un objet qui adopte la forme absolue, dans des sections carrées rendant hommage à une mécanique liquide. Grâce à tout cela, la série Venezia est une icône du luxe, une question d'élégance discrète et allusive.

Venezia

Glas auf Glas. Transparenz auf Farbe.

Die hohe Kunst des Glasblasens, die in Murano zuhause ist, in Verbindung mit noblen Elementen aus Gold und Silber, präzise gegliedert in einer genau definierten Strenge der Formen.

Das ist die Kollektion Venezia.

Farbiges Glas, eingeschlossen in fein geschliffenem und perfekt klarem Glas, wie Fossilien des neuen Millenniums in Kristallen, die sie vor dem Zahn der Zeit schützen.

Die Summe dieser Elemente mündet in einem Objekt mit einem Profil, das zu vibrieren scheint und klar definiert und fließend zugleich ist. Ein Objekt, das in der quadratischen Geometrie seiner Sektionen zur absoluten Perfektion einer Erscheinungsform wird, welche den Gesetzen der Mechanik und des Wassers huldigt.

So wird die Kollektion Venezia zu einer Ikone des Luxus und zum Stellvertreter einer gleichzeitig unaufdringlichen und an Anspielungen reichen Eleganz.

Venezia

Vidrio sobre vidrio. Las transparencias sobre los colores.

Las destacadas características artesanales del vidrio soplado de Murano se combinan con magníficos detalles de oro y plata y se plasman con un rigor geométrico de exactitud admirable. Esta es la serie Venecia.

Almas de vidrio de distintos colores, encerradas en cuerpos de vidrio transparente esmerilado. Parecen fósiles del nuevo Milenio, hundidos en cristales que los protegen contra el paso del tiempo.

Nace así un objeto de bordes vibrantes y de perfil nítido y móvil a la vez. Un objeto, que se adueña de la forma absoluta, en las secciones cuadradas, para rendir homenaje a una mecánica líquida.

Todo ello convierte a la serie Venecia en un icono del lujo y en una cuestión de elegancia discreta y evocadora.







ART. 39 5904S-39 5848C5(2PZ)
Batteria lavabo 3 fori – maniglie in vetro di Murano Argento/Nero.
3-Hole washbasin mixer – handle of Murano glass Silver/Black.
Mélangeur lavabo 3 trous – manettes en verre de Murano Argent/Noir.
Dreiloch-Waschtischarmatur – Handgriff aus Murano Glas Silber/Schwarz.
Bateria lavabo 3 elementos – maneta de cristal de Murano Plata/Negro.





ART. 39 584C5
 Maniglie in vetro di Murano Argento/
 Nero.
 Handle of Murano glass Silver/Black.
 Manettes en verre de Murano Argent/Noir.
 Handgriff aus Murano Glas Silber/
 Schwarz.
 Maneta de cristal de Murano Plata/
 Negro.

ART. 39 5905S-39 584C5(2PZ)
 Batteria lavabo alto 3 fori – maniglie in
 vetro di Murano Argento/Nero.
 3-hole high washbasin mixer – handle
 of Murano glass Silver/Black.
 Mélangeur de lavabo surélevé 3 trous –
 manettes en verre de Murano Argent/Noir.
 Dreiloch Waschisch Armatur – Handgriff
 aus Murano Glas Silber/Schwarz.
 Bateria lavabo alto 3 piezas – maneta
 de cristal de Murano Plata/Negro.

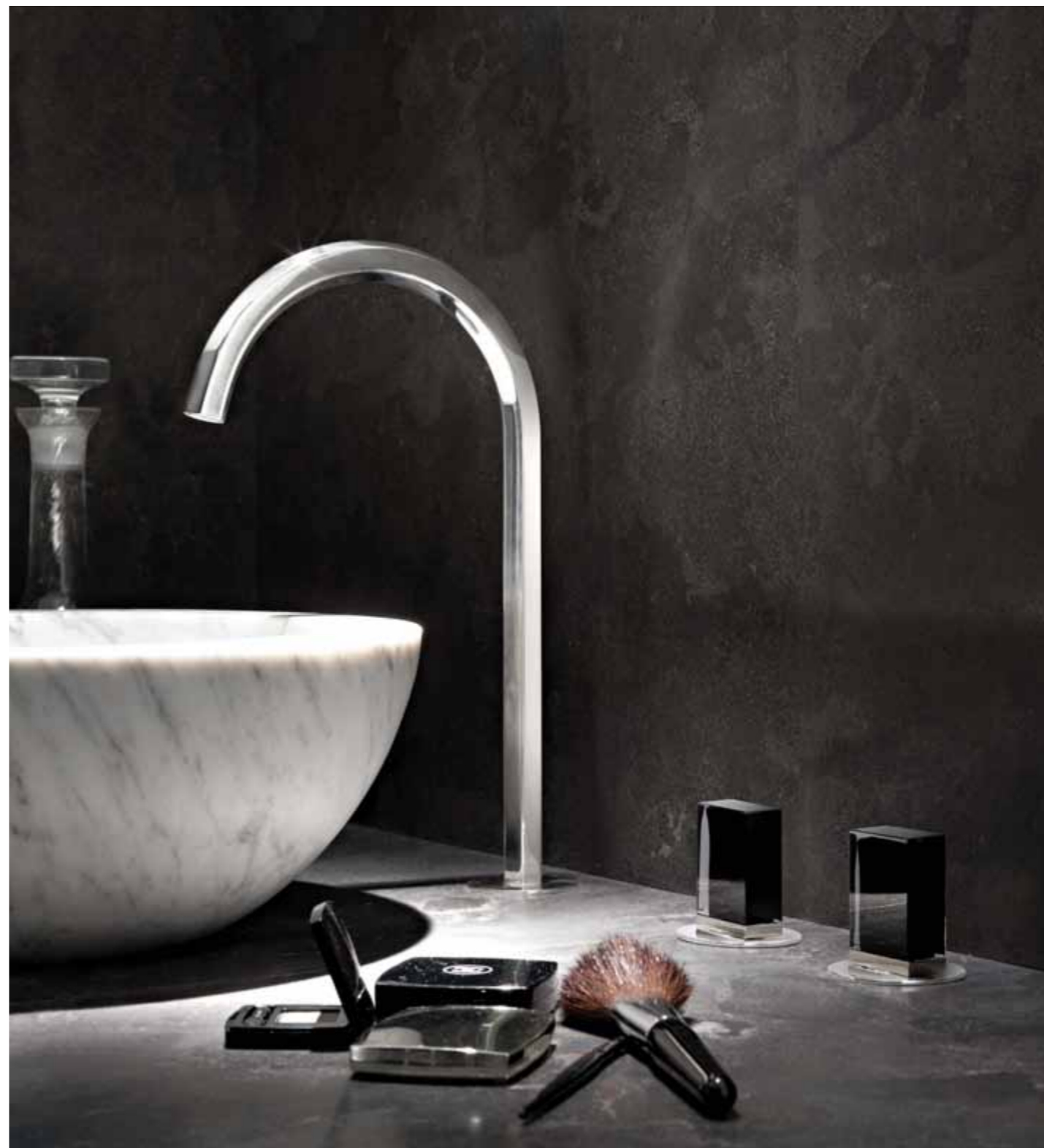



ART. 5913A/39 5913SB-39 5848C5(2PZ)
 Gruppo lavabo a parete – maniglie in vetro di Murano Argento/Nero.
 Wall mounted washbasin mixer – handle of Murano glass Silver/Black.
 Mélangeur lavabo mural – manettes en verre de Murano Argent/Noir.
 Wand-Waschtischarmatur – Handgriff aus Murano Glas Silber/Schwarz.
 Bateria lavabo a pared – maneta de cristal de Murano Plata/Negro.

ART. 39 5962SF-39 5848C5(2PZ)
 Gruppo bidet monoforo – maniglie in vetro di Murano Argento/Nero.
 1-Hole bidet mixer – handle of Murano glass Silver/Black.
 Mélangeur bidet monotrou – manettes en verre de Murano Argent/Noir.
 Einloch-Bidetarmatur – Handgriff aus Murano Glas Silber/Schwarz.
 Monobloc bide – maneta de cristal de Murano Plata/Negro.

ART. 5911A/39 5911SB-39 5848C5(2PZ)
 Batteria bidet 3 fori.
 3-Hole bidet mixer.
 Mélangeur bidet 3 trous.
 Dreiloch-Bidetarmatur.
 Bateria bide 3 elementos.





ART. 6002A/39 6002SB-39 5848C5 (2PZ)-39 8037-39 8033-39 5943
 Miscelatore termostatico vasca/doccia incasso con 2 uscite, presa d'acqua, doccia VENEZIA, flessibile, con maniglia – braccio doccia – soffione 360.
 Thermostatic built-in bathtub/shower mixer with 2 outlets, waterplug, VENEZIA handshower, PVC flexible and handle – showerarm – 360 showerhead.
 Mitigeur thermostatique bain-douche/douche à encastrer avec 2 sorties d'eau, prise d'eau, douchette VENEZIA, flexible et manette – bras de douche – pomme de douche 360.
 Thermostat UP-Wannen/Brausemischer mit 2 Abgängen, UP-Anschlussbogen, VENEZIA Handbrause, Schlauch und Griff – Wandarm – 360 Kopfbrause.
 Monomando termostático baño ducha/ducha empotrado con 2 salidas, toma de agua, teleducha VENEZIA, flexo, con maneta – brazo ducha – rociador 360.

ART. 6185A/39 6185SB-39 5848C5-39 5943-39 8033-39 8037
 Miscelatore vasca/doccia incasso con deviatore, con maniglia – braccio doccia – soffione ø 360 mm – set doccia VENEZIA.
 Built-in bathtub/shower mixer with diverter with handle – shower arm – ø 360 mm headshower – VENEZIA shower set.
 Mitigeur bain-douche/douche à encastrer avec inverseur, avec manette – bras de douche – pomme de douche ø 360 mm – combiné de douche VENEZIA.
 UP-Wannen und Brausemischer/ mit Umsteller, mit Handgriff – Wandarm – ø 360 mm Kopfbrause – VENEZIA Brauseset.
 Monomando baño ducha/ducha empotrado con desviador, con maneta – brazo ducha – rociador ø 360 mm – conjunto de ducha VENEZIA.





ART. 6003A/39 6003SB-39 5848C5(3PZ)-39 5943-8035A/39 8035B

Miscelatore termostatico vasca/doccia incasso con 3 uscite, presa d'acqua, doccia VENEZIA, flessibile, con maniglia – soffione doppio Milano con funzione pioggia e cascata.
Thermostatic built-in bathtub/shower mixer with 3 outlets, waterplug, VENEZIA handshower, PVC flexible and handle – Milano double showerhead, rain and cascade flow.
Mitigeur thermostatique bain-douche/ douche à encastrer avec 3 sorties d'eau, prise d'eau, douchette VENEZIA, flexible et manette – pomme de douche double Milano, jet à pluie et à cascade.
Thermostat UP-Wannen/Brausemischer mit 3 Abgängen, UP-Anschlussbogen, VENEZIA Handbrause, Schlauch und Griff – Milano Doppelkopfbrause, Regen – und Schwallbrause.
Monomando termostático baño ducha/ ducha empotrado con 3 salidas, toma de agua, teleducha VENEZIA, flexo, con maneta – rociador doble Milano con funciones lluvia y cascada.



ART. 39 5965S-39 5848C5(2PZ)
 Gruppo per bordo vasca con bocca,
 con deviatore, doccetta VENEZIA e
 flessibile – maniglie in vetro di Murano
 Argento/Nero.
 Deck mounted bath-tub mixer with
 spout with spout with diverter, antili-
 me VENEZIA and flexible – handle of
 Murano glass Silver/Black.
 Mélangeur bain-douche sur gorge avec
 bec avec inverseur, douchette VENEZIA
 et flexible – manettes en verre de
 Murano Argent/Noir.
 Fünfloch-Wannenrandmischer, mit
 Umsteller, VENEZIA Handbrause und
 Schlauch – Handgriff aus Murano Glas
 Silber/Schwarz.
 Grupo bañera repisa horizontal con
 caño con inversor, ducha VENEZIA y
 flexo – maneta de cristal de Murano
 Plata/Negro.



ART. 5943
 Completo doccia VENEZIA.
 Shower set with VENEZIA handspray.
 Combiné de douche VENEZIA.
 Brauseset mit VENEZIA Handbrause.
 Conjunto de ducha con teleducha
 VENEZIA.

ART. 6185A/39 6185SB-39 5848C5-39 5943
 Miscelatore vasca/doccia incasso
 con deviatore, con maniglia –
 set doccia VENEZIA.
 Built-in bathtub/shower mixer
 with diverter, with handle –
 VENEZIA shower set.
 Mitigeur bain-douche/douche
 à encastrer avec inverseur, avec
 manette – combiné de douche VENEZIA.
 UP-Wannen und Brausemischer/
 mit Umsteller, mit Handgriff –
 VENEZIA Brauseset.
 Monomando baño ducha/ducha
 empotrado con desviador, con
 maneta – conjunto de ducha VENEZIA.









ART. 39 5904S-39 5848CD
 Batteria lavabo 3 fori – maniglie in vetro di Murano Argento/Blu.
 3-Hole washbasin mixer – handle of Murano glass Silver/Blue.
 Mélangeur lavabo 3 trous – manettes en verre de Murano Argent/Bleu.
 Dreiloch-Waschtischarmatur – Handgriff aus Murano Glas Silber/Blau.
 Bateria lavabo 3 elementos – maneta de cristal de Murano Plata/Azul.

ART. 39 5904S-39 5848CB
 Batteria lavabo 3 fori – maniglie in vetro di Murano Argento/Bianco.
 3-Hole washbasin mixer – handle of Murano glass Silver/White.
 Mélangeur lavabo 3 trous – manettes en verre de Murano Argent/Blanc.
 Dreiloch-Waschtischarmatur – Handgriff aus Murano Glas Silber/Weiss.
 Bateria lavabo 3 elementos – maneta de cristal de Murano Plata/Blanco.

ART. 39 5904S-39 5848CC
 Batteria lavabo 3 fori – maniglie in vetro di Murano Argento/Rosso.
 3-Hole washbasin mixer – handle of Murano glass Silver/Red.
 Mélangeur lavabo 3 trous – manettes en verre de Murano Argent/Rouge.
 Dreiloch-Waschtischarmatur – Handgriff aus Murano Glas Silber/Rot.
 Bateria lavabo 3 elementos – maneta de cristal de Murano Plata/Rojo.



ART. 5913A/5913SB-5848(2PZ)
Gruppo lavabo a parete – maniglie
Cromo/Cromo.
Wall mounted washbasin mixer –
handle Chrome/Chrome.
Mélangeur lavabo mural – manettes
Chrome/Chromé.
Wand-Waschtischarmatur – Handgriff
Chrom/Chrom.
Bateria lavabo a pared – maneta
Cromo/Cromo.



ART. 5913A/5913SB-5848(2PZ)



ART. 5948
 Maniglie dupont cromo.
 Handle dupont chrome.
 Manettes dupont chromé.
 Handgriff dupont chrom.
 Maneta dupont cromo.

ART. 5913A/5913SB-5948(2PZ)
 Gruppo lavabo a parete –
 maniglie dupont cromo.
 Wall mounted washbasin mixer –
 handle dupont chrome.
 Mélangeur lavabo mural –
 manettes dupont chromé.
 Wand-Waschtischarmatur –
 Handgriff dupont chrom.
 Bateria lavabo a pared –
 maneta dupont cromo.





ART. 01 5904S-01 5848C5(2PZ)
 Batteria lavabo 3 fori – maniglie in vetro di Murano Oro/Nero.
 3-Hole washbasin mixer – handle of Murano glass Gold/Black.
 Mélangeur lavabo 3 trous – manettes en verre de Murano Doré/Noir.
 Dreiloch-Waschtischarmatur – Handgriff aus Murano Glas Golden/Schwarz.
 Bateria lavabo 3 elementos – maneta de cristal de Murano Oro/Negro.

ART. 01 5904S-01 5848(2PZ)
 Batteria lavabo 3 fori – maniglie Oro/Oro.
 3-Hole washbasin mixer – handle Gold/Gold.
 Mélangeur lavabo 3 trous – manettes Doré/Doré.
 Dreiloch-Waschtischarmatur – Handgriff Golden/Golden.
 Bateria lavabo 3 elementos – maneta Oro/Oro.





ART. 5904S-5848

Batteria lavabo 3 fori – maniglie.
3-Hole washbasin mixer – handle.
Mélangeur lavabo 3 trous – manettes.
Dreiloch-Waschtischarmatur – Handgriff.
Bateria lavabo 3 elementos – maneta.



ART. 5905S-5848

Batteria lavabo 3 fori con bocca alta – maniglie.
3-Hole high washbasin mixer – handle.
Mélangeur lavabo surélevé 3 trous – manettes.
Dreiloch-Waschtischarmatur – Handgriff.
Bateria lavabo alto 3 elementos – maneta.



ART. 6001A/6001SB-5848

Miscelatore termostatico vasca/doccia incasso con 1 uscita – maniglia.
Thermostatic built-in bathtub/shower mixer with 1 outlet – handle.
Mitigeur thermostatique bain-douche/douche à encastrer avec 1 sortie d'eau – manette.
Thermostat UP-Wannen/Brausemischer mit 1 Abgängen – Handgriff.
Monomando termostático baño ducha/ducha empotrado con 1 salida – maneta.



ART. 6002A/6002SB-5848

Miscelatore termostatico vasca/doccia incasso con 2 uscite – maniglia.
Thermostatic built-in bathtub/shower mixer with 2 outlets – handle.
Mitigeur thermostatique bain-douche/douche à encastrer avec 2 sorties d'eau – manette.
Thermostat UP-Wannen/Brausemischer mit 2 Abgängen – Handgriff.
Monomando termostático baño ducha/ducha empotrado con 2 salidas – maneta.



ART. 5913A/5913SB-5848

Gruppo lavabo a parete – maniglie.
Wall mounted washbasin mixer – handle.
Mélangeur lavabo mural – manettes.
Wand-Waschtischarmatur – Handgriff.
Bateria lavabo a pared – maneta.



ART. 5962SF-5848

Gruppo bidet monoforo – maniglie.
1-Hole bidet mixer – handle.
Mélangeur bidet monotrou – manettes.
Einloch-Bidetarmatur – Handgriff.
Monobloc bide – maneta.



ART. 6003A/6003SB-5848

Miscelatore termostatico vasca/doccia incasso con 3 uscite – maniglia.
Thermostatic built-in bathtub/shower mixer with 3 outlets – handle.
Mitigeur thermostatique bain-douche/douche à encastrer avec 3 sorties d'eau – manette.
Thermostat UP-Wannen/Brausemischer mit 3 Abgängen – Handgriff.
Monomando termostático baño ducha/ducha empotrado con 3 salidas – maneta.



ART. 6000A/6003SB-5848

Miscelatore termostatico vasca/doccia incasso.
Thermostatic built-in bathtub/shower mixer.
Mitigeur thermostatique bain-douche/douche à encastrer.
Thermostat UP-Wannen/Brausemischer.
Monomando termostático baño ducha/ducha empotrado.



ART. 5911A/5911SB-5848

Batteria bidet 3 fori – maniglie.
3-Hole bidet mixer – handle.
Mélangeur bidet 3 trous – manettes.
Dreiloch-Bidetarmatur – Handgriff.
Bateria bide 3 elementos – maneta.



ART. 6185A/6185SB-5848

Miscelatore vasca/doccia incasso con deviatore – maniglia.
Built-in bathtub/shower mixer with diverter – handle.
Mitigeur bain-douche/douche à encastrer avec inverseur – manette.
UP-Wannen und Brausemischer/ mit Umsteller – Handgriff.
Monomando baño ducha/ducha empotrado con desviador – maneta.



ART. 8035A/8035B

Soffione doppio Milano con funzione pioggia e cascata.
Milano double shower head, rain and cascade flow.
Pomme de douche double Milano jet pluie et cascade.
Milano Doppelkopfbrause Regen – und Schwalldusche.
Rociador doble Milano con funciones lluvia y cascada.



ART. 8037-8033

Braccio doccia – soffione 360.
Showerarm – 360 showerhead.
Bras de douche – pomme de douche 360.
Wandarm – 360 Kopfbrause.
Braço ducha – rociador 360.

ART. 9849

Doccetta VENEZIA.
VENEZIA handspray.
Douchette VENEZIA.
VENEZIA Handbrause.
Teleducha VENEZIA.



ART. 5943

Completo doccia VENEZIA.
Shower set with VENEZIA handspray.
Combiné de douche VENEZIA.
Brauseset mit VENEZIA Handbrause.
Conjunto de ducha con teleducha VENEZIA.



02

Cromo / Cromo
Chrome / Chrome
Chrome / Chromé
Chrom / Chrom
Cromo / Cromo



39

Argento/Argento
Silver/Silver
Argent/Argent
Silber/Silber
Plata/Plata



01

Oro/Oro
Gold/Gold
Doré/Doré
Golden/Golden
Oro/Oro



95

Pvd Nickel
Pvd Nickel
Pvd Nickel
Pvd Nickel
Pvd Nickel



C5 02

Nero/Cromo
Black/Chrome
Noir/Chromé
Schwarz/Chrom
Negro/Cromo



C5 39

Nero/Argento
Black/Silver
Noir/Argent
Schwarz/Silber
Negro/Plata



C5 01

Nero/Oro
Black/Gold
Noir/Doré
Schwarz/Golden
Negro/Oro



C5 95

Nero/Pvd Nickel
Black/Pvd Nickel
Noir/Pvd Nickel
Schwarz/Pvd Nickel
Negro/Pvd Nickel



CB 02

Bianco/Cromo
White/Chrome
Blanc/Chromé
Weiss/Chrom
Blanco/Cromo



CB 39

Bianco/Argento
White/Silver
Blanc/Argent
Weiss/Silber
Blanco/Plata



CB 01

Bianco/Oro
White/Gold
Blanc/Doré
Weiss/Golden
Blanco/Oro



CB 95

Bianco/Pvd Nickel
White/Pvd Nickel
Blanc/Pvd Nickel
Weiss/Pvd Nickel
Blanco/Pvd Nickel

ART. 5965S-5848

Gruppo per bordo vasca con deviatore, senza bocca, doccetta VENEZIA e flessibile – maniglie.

Deck mounted bath-tub mixer with diverter, without spout, VENEZIA handshower and flexible – handle. Mélangeur bain-douche sur gorge, sans bec, avec inverseur, douchette VENEZIA et flexible – manettes.

Vierloch-Wannenrandmischer mit Umsteller, ohne Auslauf, VENEZIA Handbrause und Schlauch – Handgriff. Batería baño ducha de repisa sin caño, con teleducha VENEZIA, flexo – maneta.



ART. 5965S-5848

Gruppo per bordo vasca con bocca, con deviatore, doccetta VENEZIA e flessibile – maniglie.

Deck mounted bath-tub mixer with spout with diverter, antilime VENEZIA and flexible – handle. Mélangeur bain-douche sur gorge avec bec avec inverseur, douchette VENEZIA et flexible – manettes.

Fünfloch-Wannenrandmischer, mit Umsteller, VENEZIA Handbrause und Schlauch – Handgriff. Grupo bañera repisa horizontal con caño con inversor, ducha VENEZIA y flexo – maneta.



CC 02

Rosso/Cromo
Red/Chrome
Rouge/Chromé
Rot/Chrom
Rojo/Cromo



CC 39

Rosso/Argento
Red/Silver
Rouge/Argent
Rot/Silber
Rojo/Plata



CC 01

Rosso/Oro
Red/Gold
Rouge/Doré
Rot/Golden
Rojo/Oro



CC 95

Rosso/Pvd Nickel
Red/Pvd Nickel
Rouge/Pvd Nickel
Rot/Pvd Nickel
Rojo/Pvd Nickel



CD 02

Blu/Cromo
Blue/Chrome
Bleu/Chromé
Blaue/Chrom
Azul/Cromo



CD 39

Blu/Argento
Blue/Silver
Bleu/Argent
Blaue/Silber
Azul/Plata



CD 01

Blu/Oro
Blue/Gold
Bleu/Doré
Blaue/Golden
Azul/Oro



CD 95

Blu/Pvd Nickel
Blue/Pvd Nickel
Bleu/Pvd Nickel
Blaue/Pvd Nickel
Azul/Pvd Nickel



5948 02

Dupont Cromo
Dupont Chrome
Dupont Chromé
Dupont Chrom
Dupont Cromo



5948 39

Dupont Argento
Dupont Silver
Dupont Argent
Dupont Silber
Dupont Plata



5948 01

Dupont Oro
Dupont Gold
Dupont Doré
Dupont Golden
Dupont Oro



5948 95

Dupont Pvd Nickel
Dupont Pvd Nickel
Dupont Pvd Nickel
Dupont Pvd Nickel
Dupont Pvd Nickel



02

Cromo
Chrome
Chromé
Chrom
Cromo



39

Argento
Silver
Argent
Silber
Plata



01

Oro
Gold
Doré
Golden
Oro



95

Pvd Nickel
Pvd Nickel
Pvd Nickel
Pvd Nickel
Pvd Nickel

ART. 5904S

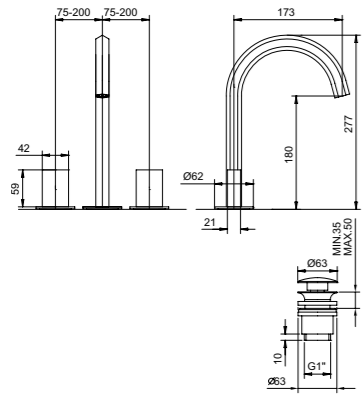

ART. 5904S

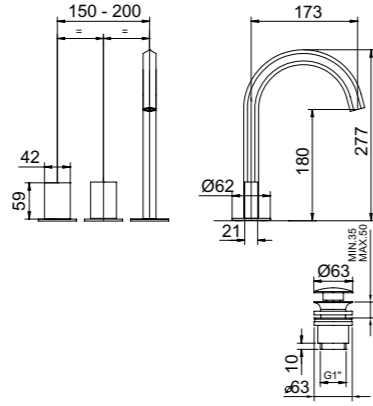

ART. 5905S

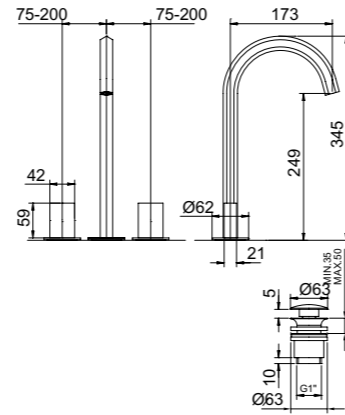

ART. 6002A/6002SB

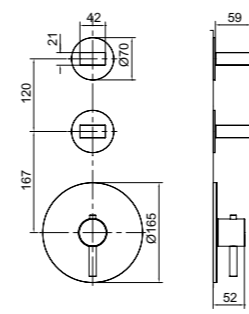

ART. 6003A/6003SB

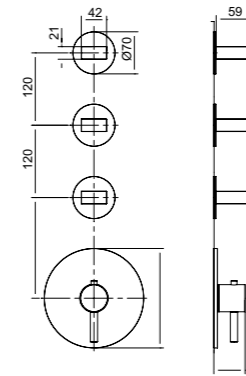

ART. 6000A/6000SB

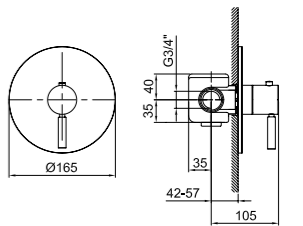

ART. 5905S

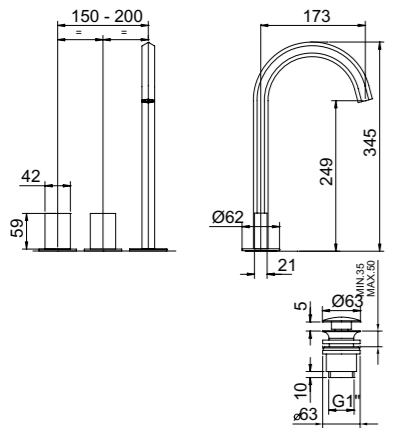

ART. 5913A/5913SB

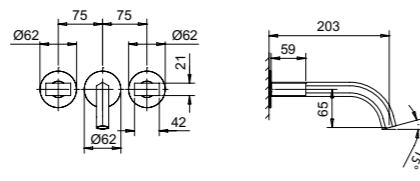

ART. 395962SF

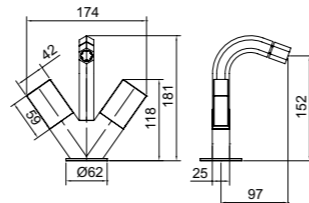

ART. 8035A/8035B

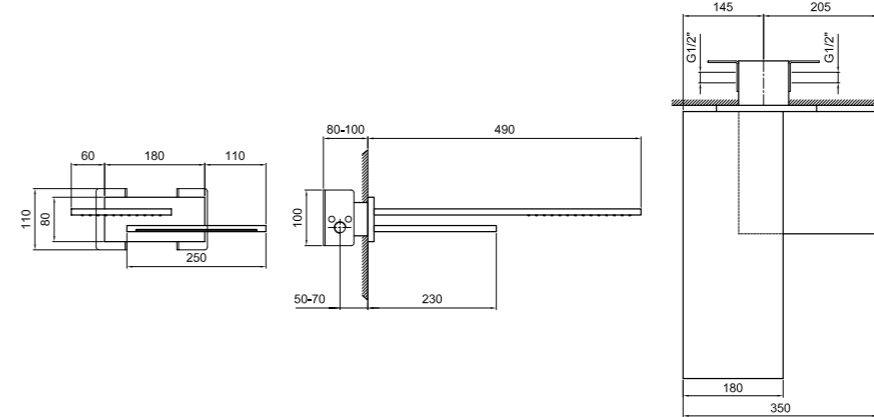

ART. 6185A/6185SB

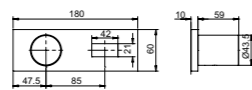

ART. 6001A/6001SB

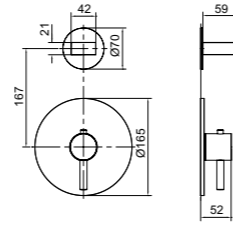

ART. 8033

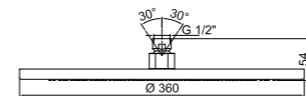

ART. 8037

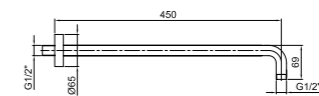

ART. 5943

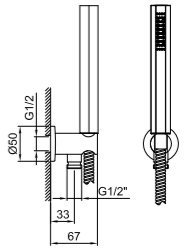

ART. 5965S

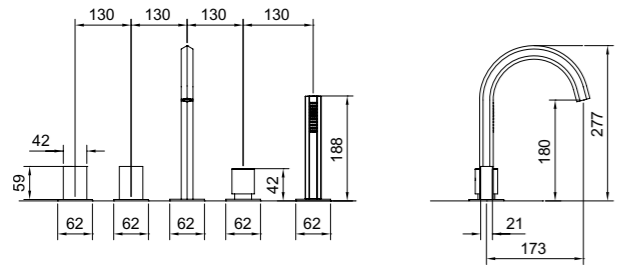

ART. 5967S

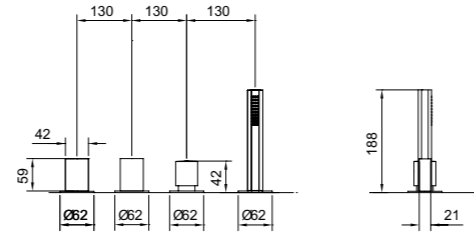

ART. 5948

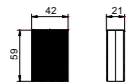

ART. 5848

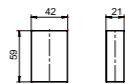

ART. 5848C

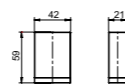

AD / Graph.x
Styling / Carin Scheve
Foto / Santi Caleca
Foto tecniche / Dario Flores d'Arcais
Fotolito / CD Cromo
Stampa / Grafiche Nava - 2010

Special thanks to /
Boffi
Glas Italia
La Murrina
La Perla
Salvatori



Fratelli Fantini S.p.A. Via M. Buonarroti, 4
28010 Pella (NO), Italia
tel. +39 0322 918411 r.a. fax +39 0322 969 530
fantini@fantini.it www.fantini.it